

# M57925L

HYBRID IC FOR DRIVING TRANSISTOR MODULES

## DESCRIPTION

M57925L is a Hybrid Integrated Circuit designed for driving Transistor Modules QM30DY, QM50DY, etc., in an Inverter application. This device operates as an isolation amplifier for Transistor Modules due to the electrical isolation between the input and output, and features a small outline of 10-pin SIP.

## FEATURES

- Electrical isolation between input and output with integrated opto-coupler.  $V_{iso}=2500V_{rms}$
- Propagation delay time .....  $t_{PLH}=2\mu s$  (TYP)
- .....  $t_{PLH}=4\mu s$  (TYP)
- Large load and sink current driving capability
- .....  $I_{OH}=-1A$  (MAX)
- .....  $I_{OLP}=-3A$  (MAX)
- Applicable with TTL input
- Small outline, 10-pin SIP package

## APPLICATION

To drive Transistor Modules for Inverter applications

## OUTLINE DRAWING

Dimensions in mm

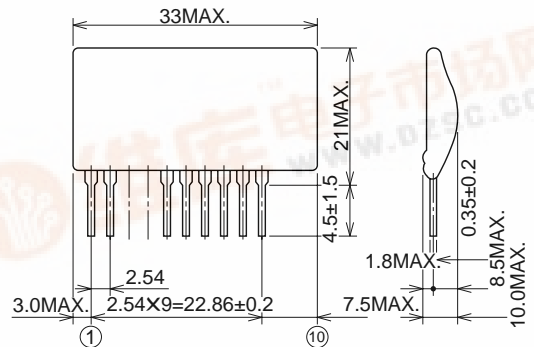

## BLOCK DIAGRAM

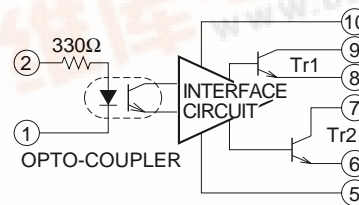

## CIRCUIT DIAGRAM

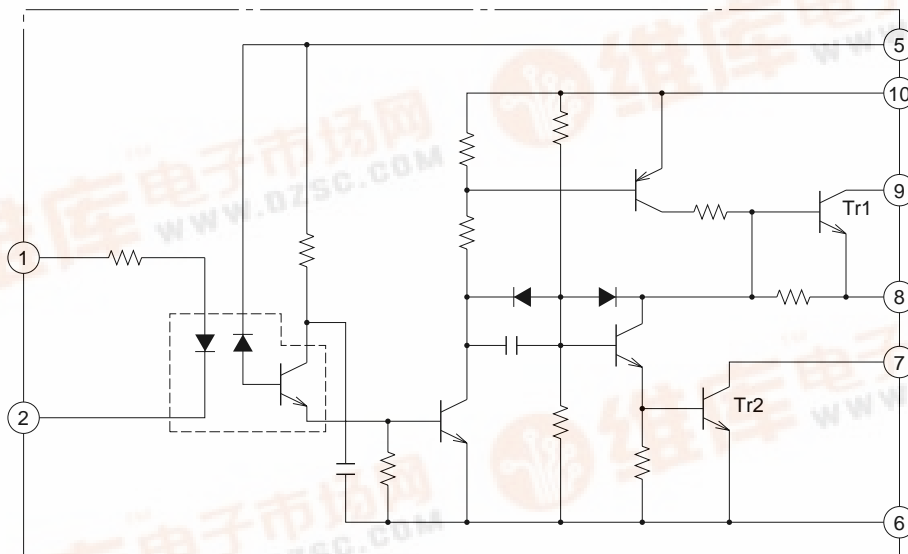

**M57925L**

HYBRID IC FOR DRIVING TRANSISTOR MODULES

**ABSOLUTE MAXIMUM RATINGS** ( $T_a = -20 \sim +70^\circ\text{C}$ , unless otherwise noted)

Symbol	Parameter	Conditions	Ratings	Unit
VCC	Supply voltage	DC	14	V
VEE	Supply voltage	DC	-6	V
VI	Input voltage	Between terminals ① and ②	-1 ~ 7	V
IOH	Output current		-1	A
IOLP		Pulse width 10 $\mu$ s, Freq. 2kHz, peak value	3	A
Viso	Isolation voltage	Sinewave voltage 60Hz/min. $T_a = 25^\circ\text{C}$	2500	V <sub>rms</sub>
T <sub>j</sub>	Junction temperature		100	$^\circ\text{C}$
T <sub>opg</sub>	Operating temperature		-20 ~ +70	$^\circ\text{C}$
T <sub>stg</sub>	Storage temperature		-25 ~ +100	$^\circ\text{C}$

**ELECTRICAL CHARACTERISTICS** ( $T_a = 25^\circ\text{C}$ ,  $V_{CC} = 8\text{V}$ , unless otherwise noted)

Symbol	Parameter	Test conditions	Limits			Unit
			Min.	Typ.	Max.	
I <sub>IH</sub>	"H" input current	$V_I = 5\text{V}$	-	12	-	mA
IOH	"H" output current	$R_{ext} = 9\Omega$	-0.8	-	-	A
IOLP	"L" output peak current	$C_{ext} = 10\mu\text{F}$ , $R_2 = 1\Omega$	-	2	-	A
PD	Internal power dissipation	$I_{OH} = -0.5\text{A}$ , $I_{OLP} = 1\text{A}$ , $f = 2\text{kHz}$ , D.F. = 50%	-	0.35	-	W
t <sub>PLH</sub>	"L-H" propagation delay time	$V_I = 0 \rightarrow 4\text{V}$ , $T_j = 100^\circ\text{C}$	-	2	4	$\mu\text{s}$
t <sub>r</sub>	"L-H" rise time	$V_I = 0 \rightarrow 4\text{V}$ , $T_j = 100^\circ\text{C}$	-	-	2	$\mu\text{s}$
t <sub>PHL</sub>	"H-L" propagation delay time	$V_I = 5 \rightarrow 0\text{V}$ , $T_j = 100^\circ\text{C}$	-	4	6	$\mu\text{s}$
t <sub>f</sub>	"H-L" fall time	$V_I = 5 \rightarrow 0\text{V}$ , $T_j = 100^\circ\text{C}$	-	-	3	$\mu\text{s}$

# M57925L

HYBRID IC FOR DRIVING TRANSISTOR MODULES

## PERFORMANCE CURVES

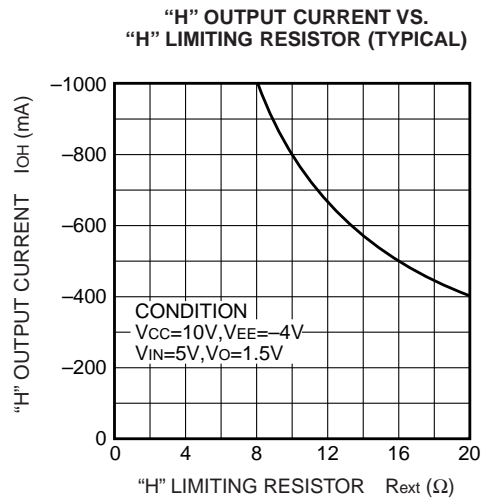
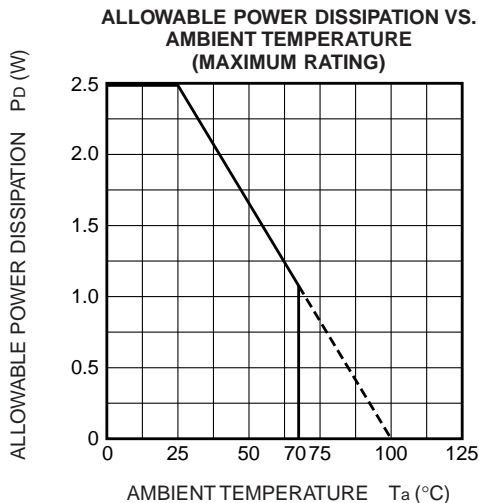
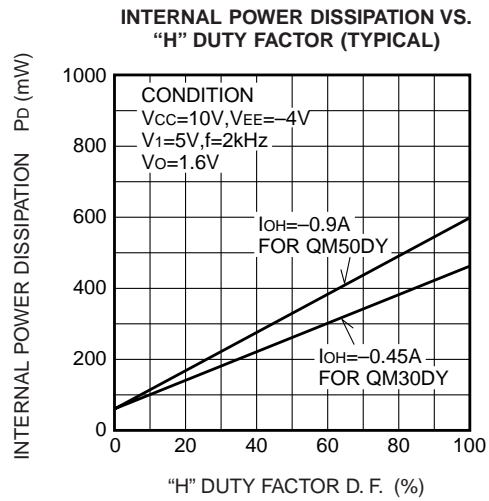
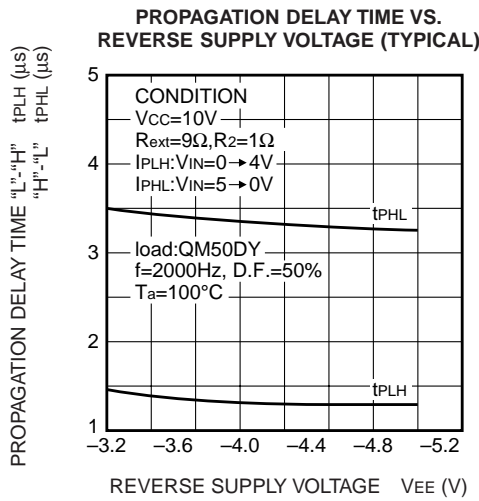
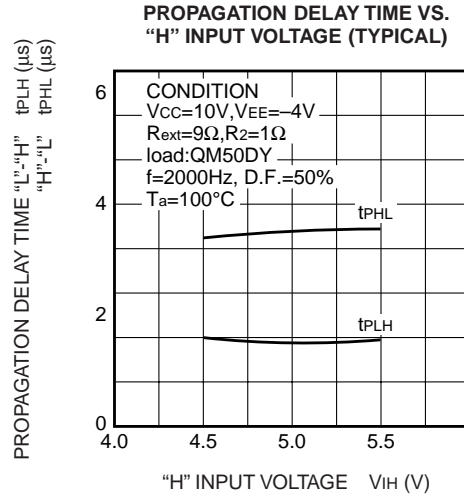
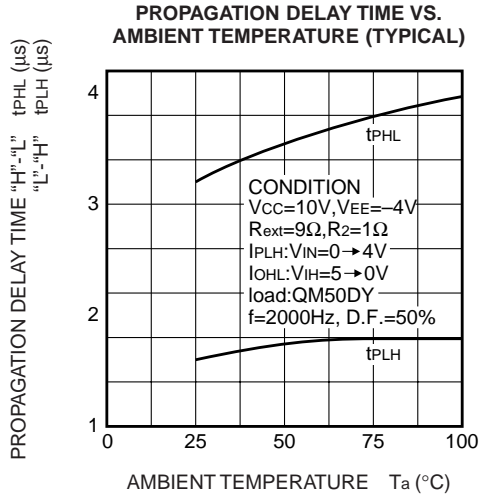

# M57925L

HYBRID IC FOR DRIVING TRANSISTOR MODULES

**"L" OUTPUT PEAK CURRENT VS. REVERSE SUPPLY VOLTAGE (TYPICAL)**

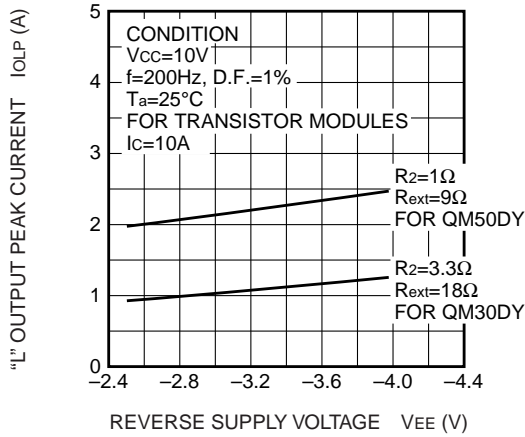

**REVERSE SUPPLY VOLTAGE VS. "L" OUTPUT VOLTAGE (TYPICAL)**

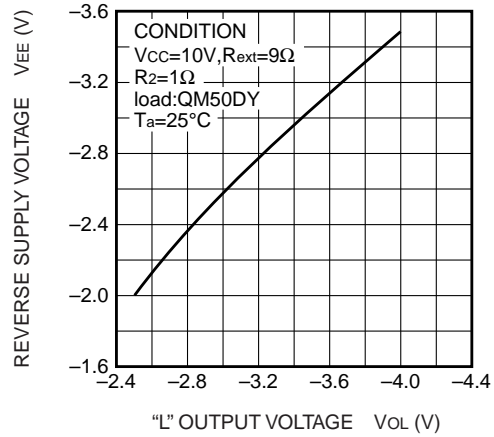

**POWER DISSIPATION OF  $R_{ext}$  VS. "H" DUTY FACTOR (TYPICAL)**

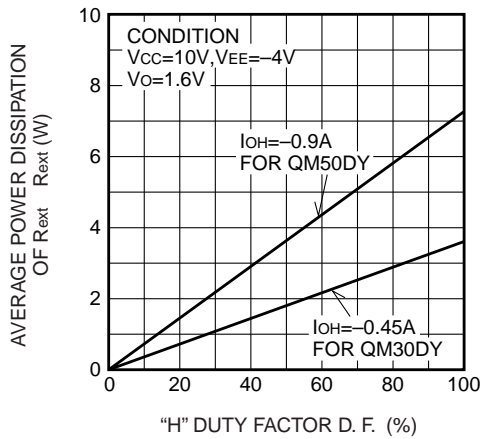

**OUTPUT CHARACTERISTIC OF FULL WAVE RECTIFYING CIRCUIT WITH CENTER-TAPPED TRANSFORMER (FOR REFERENCE)**

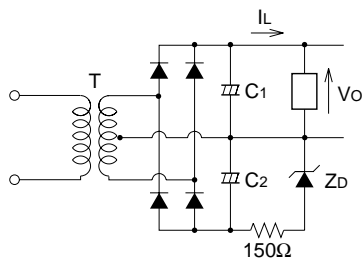
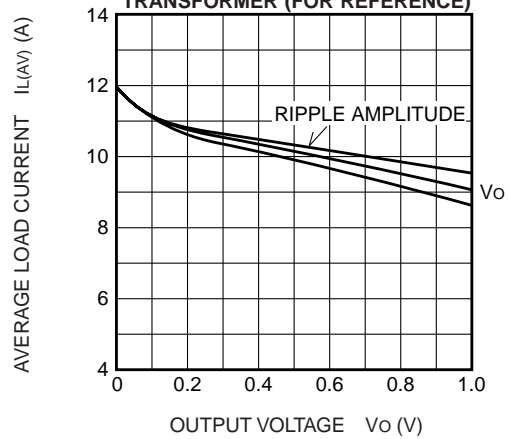

T: 8V, 1AX2 CENTER-TAPPED TRANSFORMER  
 C1: 4700 $\mu F$ , C2: 470 $\mu F$

# M57925L

HYBRID IC FOR DRIVING TRANSISTOR MODULES

## EXPLANATION OF FUNCTION

(cf. Fig. 2, 3, 4, and 5)

(1) With low input level ( $V_{in}=0 \sim 1V$ )

Tr1 ..... OFF, Tr2 ..... ON

The base terminal of transistor module is reverse biased with respect to its emitter by reverse power supply VEE.

(2) With high input level ( $V_{in}=4 \sim 5V$ )

Tr1 ..... ON, Tr2 ..... OFF

The base terminal of transistor module is forward biased and driven by the current IOH through the resistor Rext.

(3) With low input level ( $V_{in}=0 \sim 1V$ )

Tr1 ..... OFF, Tr2 ..... ON

The base terminal of transistor module is reverse biased as stated in (1) after flowing reverse recovery pulse current IOLP. The steady reverse base current is limited by the internal base-emitter resistor RBE of the transistor module.

## Typical application circuit

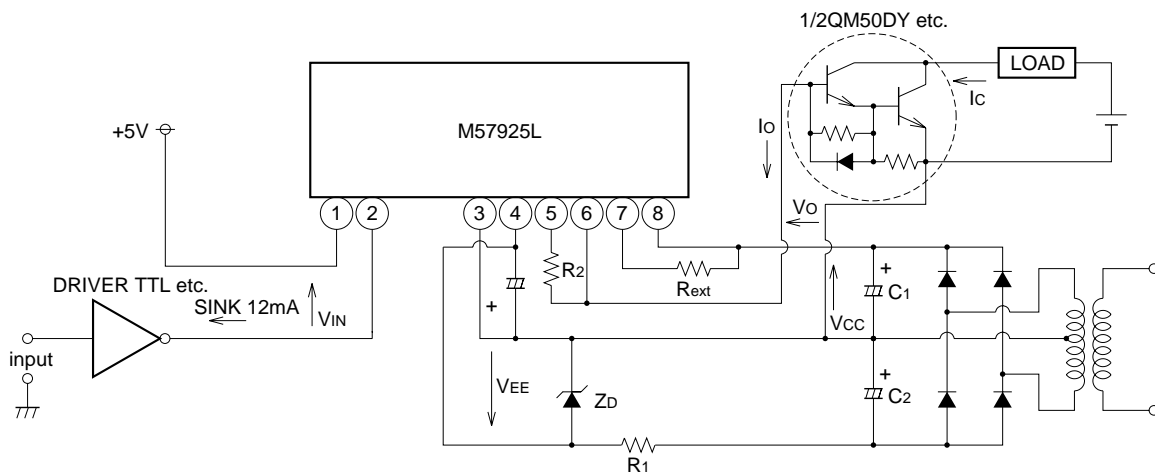

## Typical operating waveform

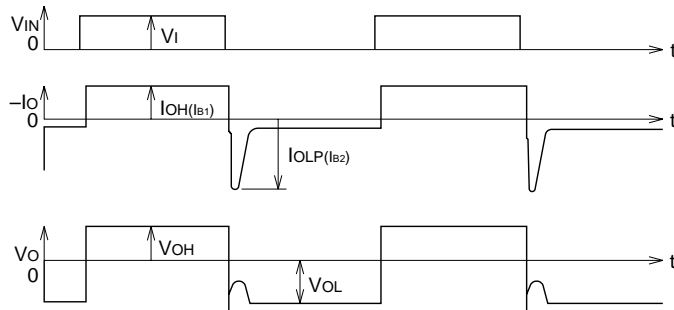

Note: IOH and IOLP correspond to base forward current Ib1 and base reverse current Ib2 of the transistor module to be driven respectively.