



M58LV064A M58LV064B

64 Mbit (4Mb x16 or 2Mb x32, Uniform Block, Burst)
3V Supply Flash Memories

PRELIMINARY DATA

FEATURES SUMMARY

- WIDE DATA BUS for HIGH BANDWIDTH
 - M58LV064A: x16
 - M58LV064B: x16/x32
- SUPPLY VOLTAGE
 - $V_{DD} = 3.0$ to $3.6V$ M58LV064 core supply
 - $V_{DDQ} = 1.8$ to V_{DD} for I/O Buffers
- SYNCHRONOUS/ASYNCHRONOUS READ
 - Synchronous Burst read
 - Pipelined Synchronous Burst Read
 - Asynchronous Random Read
 - Asynchronous Address Latch Controlled Read
 - Page Read
- ACCESS TIME
 - Synchronous Burst Read up to 66MHz
 - Asynchronous Page Mode Read 150/25ns
 - Random Read 150ns
- PROGRAMMING TIME
 - 16 Word or 8 Double-Word Write Buffer
 - $12\mu s$ Word effective programming time
- 64 UNIFORM 64 KWord MEMORY BLOCKS
- BLOCK PROTECTION/ UNPROTECTION
- PROGRAM and ERASE SUSPEND
- OTP SECURITY AREA
- COMMON FLASH INTERFACE
- 100,000 PROGRAM/ERASE CYCLES per BLOCK
- ELECTRONIC SIGNATURE
 - Manufacturer Code: 0020h
 - Device Code M58LV064A: 0015h
 - Device Code M58LV064B: 0014h

Figure 1. Packages



TABLE OF CONTENTS

SUMMARY DESCRIPTION..... 6

 Figure 2. Logic Diagram 7

 Table 1. Signal Names 7

 Figure 3. TSOP56 Connections..... 8

 Figure 4. TBGA64 Connections for M58LV064A (Top view through package)..... 9

 Figure 5. TBGA80 Connections for M58LV064B (Top view through package)..... 10

 Figure 6. Block Addresses..... 11

SIGNAL DESCRIPTIONS 12

 Address Inputs (A1-A22). 12

 Data Inputs/Outputs (DQ0-DQ31). 12

 Chip Enable (E). 12

 Output Enable (G). 12

 Write Enable (W). 12

 Reset/Power-Down (RP). 12

 Latch Enable (L). 12

 Clock (K).. 13

 Burst Address Advance (B). 13

 Valid Data Ready (R). 13

 Word Organization (WORD).. 13

 Ready/Busy (RB). 13

 Program/Erase Enable (V_{PP}). 13

 V_{DD} Supply Voltage. 13

 Input/Output Supply Voltage (V_{DDQ}). 14

 Ground (V_{SS}). 14

 Ground (V_{SSQ}). 14

BUS OPERATIONS..... 15

Asynchronous Bus Operations 15

 Asynchronous Bus Read. 15

 Asynchronous Latch Controlled Bus Read 15

 Asynchronous Page Read. 15

 Asynchronous Bus Write 15

 Asynchronous Latch Controlled Bus Write 15

 Output Disable. 16

 Standby 16

 Automatic Low Power..... 16

 Power-Down..... 16

 Table 2. Asynchronous Bus Operations 16

Synchronous Bus Operations 17

 Synchronous Burst Read. 17

 Synchronous Pipelined Burst Read. 17

 Synchronous Burst Read Suspend 17

Table 3. Synchronous Burst Read Bus Operations	18
Table 4. Address Latch Cycle for Optimum Pipelined Synchronous Burst Read	18
Figure 7. Synchronous Burst Read Operation.	19
Figure 8. Example Synchronous Pipelined Burst Read Operation	19
Figure 9. Example Burst Address Advance and Burst Abort operations	20
Burst Configuration Register	21
Read Select Bit (M15)	21
X-Latency Bits (M14-M11).	21
Y-Latency Bit (M9).	21
Valid Data Ready Bit (M8).	21
Burst Type Bit (M7)..	21
Valid Clock Edge Bit (M6)..	21
Latch Enable Bit (M3)	21
Burst Length Bit (M2-M0).	21
Table 5. Burst Configuration Register	22
Table 6. Burst Type Definition (x16 Bus Width).	23
Table 7. Burst Type Definition (x32 Bus Width).	23
Table 8. Burst Performance.	24
COMMAND INTERFACE	25
Read Memory Array Command.	25
Read Electronic Signature Command.	25
Read Query Command..	25
Read Status Register Command.	25
Clear Status Register Command.	25
Block Erase Command	25
Write to Buffer and Program Command..	25
Program/Erase Suspend Command	26
Program/Erase Resume Command	26
Set Burst Configuration Register Command.	27
Block Protect Command..	27
Blocks Unprotect Command..	27
Table 9. Commands	28
Table 10. Read Electronic Signature.	28
Table 11. Program, Erase Times and Program Erase Endurance Cycles	29
STATUS REGISTER	30
Program/Erase Controller Status (Bit 7)	30
Erase Suspend Status (Bit 6)	30
Erase Status (Bit 5)	30
Program Status (Bit 4).	30
VPP Status (Bit 3)	31
Program Suspend Status (Bit 2)	31
Block Protection Status (Bit 1).	31
Reserved (Bit 0).	31

M58LV064A, M58LV064B

Table 12. Status Register Bits	32
MAXIMUM RATING.	33
Table 13. Absolute Maximum Ratings.	33
DC and AC PARAMETERS	34
Table 14. Operating and AC Measurement Conditions.	34
Figure 10. AC Measurement Input Output Waveform	34
Figure 11. AC Measurement Load Circuit	34
Table 15. Capacitance.	34
Table 16. DC Characteristics.	35
Figure 12. Asynchronous Bus Read AC Waveforms.	36
Table 17. Asynchronous Bus Read AC Characteristics.	36
Figure 13. Asynchronous Latch Controlled Bus Read AC Waveforms	37
Table 18. Asynchronous Latch Controlled Bus Read AC Characteristics	37
Figure 14. Asynchronous Page Read AC Waveforms	38
Table 19. Asynchronous Page Read AC Characteristics	38
Figure 15. Asynchronous Write AC Waveform, Write Enable Controlled	39
Figure 16. Asynchronous Latch Controlled Write AC Waveform, Write Enable Controlled.	39
Table 20. Asynchronous Write and Latch Controlled Write AC Characteristics, Write Enable Controlled.	40
Figure 17. Asynchronous Write AC Waveforms, Chip Enable Controlled	41
Figure 18. Asynchronous Latch Controlled Write AC Waveforms, Chip Enable Controlled	41
Table 21. Asynchronous Write and Latch Controlled Write AC Characteristics, Chip Enable Controlled	42
Figure 19. Synchronous Burst Read AC Waveform	43
Figure 20. Synchronous Burst Read - Continuous - Valid Data Ready Output	44
Table 22. Synchronous Burst Read AC Characteristics	45
Figure 21. Reset, Power-Down and Power-up AC Waveform.	46
Table 23. Reset, Power-Down and Power-up AC Characteristics	46
PACKAGE MECHANICAL	47
Figure 22. TSOP56 - 56 lead Plastic Thin Small Outline, 14 x 20 mm, Package Outline	47
Table 24. TSOP56 - 56 lead Plastic Thin Small Outline, 14 x 20 mm, Package Mechanical Data	47
Figure 23. TBGA64 - 10x13mm, 8 x 8 ball array 1mm pitch, Package Outline	48
Table 25. TBGA64 - 10x13mm, 8 x 8 ball array, 1 mm pitch, Package Mechanical Data.	48
Figure 24. TBGA80 - 10x13mm, 8 x 10 ball array, 1mm pitch, Package Outline	49
Table 26. TBGA80 - 10x13mm, 8 x 10 ball array, 1mm pitch, Package Mechanical Data	49
PART NUMBERING.	50
Table 27. Ordering Information Scheme	50
APPENDIX A. BLOCK ADDRESS TABLE.	51
Table 28. Block Addresses	51
APPENDIX B. COMMON FLASH INTERFACE - CFI.	52

Table 29. Query Structure Overview	52
Table 30. CFI - Query Address and Data Output	53
Table 31. CFI - Device Voltage and Timing Specification	54
Table 32. Device Geometry Definition	55
Table 33. Block Status Register	55
Table 34. Extended Query information	56
APPENDIX C. FLOW CHARTS	57
Figure 25. Write to Buffer and Program Flowchart and Pseudo Code	57
Figure 26. Program Suspend & Resume Flowchart and Pseudo Code	58
Figure 27. Erase Flowchart and Pseudo Code	59
Figure 28. Erase Suspend & Resume Flowchart and Pseudo Code	60
Figure 29. Command Interface and Program Erase Controller Flowchart (a)	61
Figure 30. Command Interface and Program Erase Controller Flowchart (b)	62
Figure 31. Command Interface and Program Erase Controller Flowchart (c)	63
REVISION HISTORY	64
Table 35. Document Revision History	64

SUMMARY DESCRIPTION

M58LV064 is a 64Mbit (4Mb x16 or 2Mb x32) non-volatile memory that can be read, erased and re-programmed. These operations can be performed using a single low voltage (2.7V to 3.6V) core supply. On power-up the memory default to Read mode with an asynchronous bus where it can be read in the same way as a non-burst Flash memory.

The memory is divided into 64 blocks of 1Mbit that can be erased independently so it is possible to preserve valid data while old data is erased. Program and Erase commands are written to the Command Interface of the memory. An on-chip Program/Erase Controller simplifies the process of programming or erasing the memory by taking care of all of the special operations that are required to update the memory contents. The end of a Program or Erase operation can be detected and any error conditions identified in the Status Register. The command set required to control the memory is consistent with JEDEC standards.

The Write Buffer allows the microprocessor to program from 4 to 16 Words (or from 2 to 8 Double Words) in parallel, both speeding up the programming and freeing up the microprocessor to perform other work. The minimum buffer size for a program operation is a 4 Word (or 2 Double Word) page. A page can only be programmed once between Erase operations.

Erase can be suspended in order to perform either Read or Program in any other block and then resumed. Program can be suspended to Read data in any other block and then resumed. Each block can be programmed and erased over 100,000 cycles.

Individual block protection against Program or Erase is provided for data security. All blocks are protected during power-up. The protection of the blocks is non-volatile; after power-up the protec-

tion status of each block is restored to the state when power was last removed. Software commands are provided to allow protection of some or all of the blocks and to cancel all block protection bits simultaneously. All Program or Erase operations are blocked when the Program Erase Enable input Vpp is low.

The Reset/Power-Down pin is used to apply a Hardware Reset to the memory and to set the device in deep power-down mode. It can also be used to temporarily disable the protection mechanism.

In asynchronous mode Chip Enable, Output Enable and Write Enable signals control the bus operation of the memory. An Address Latch input can be used to latch addresses in Latch Controlled mode. Together they allow simple, yet powerful, connection to most microprocessors, often without additional logic.

In synchronous mode all Bus Read operations are synchronous with the Clock. Chip Enable and Output Enable select the Bus Read operation; the address is Latched using the Latch Enable inputs and the address is advanced using Burst Address Advance. The signals are compatible with most microprocessor burst interfaces.

A One Time Programmable (OTP) area is included for security purposes. Either 1K Words (x16 Bus Width) or 1K Double-Words (x32 Bus Width) is available in the OTP area. The process of reading from and writing to the OTP area is not published for security purposes; contact STMicroelectronics for details on how to use the OTP area.

The memory is offered in various packages. The M58LV064A is available in TSOP56 (14 x 20 mm) and TBGA64 (1mm pitch). The M58LV064B is available in TBGA80 (1mm pitch).

Figure 2. Logic Diagram

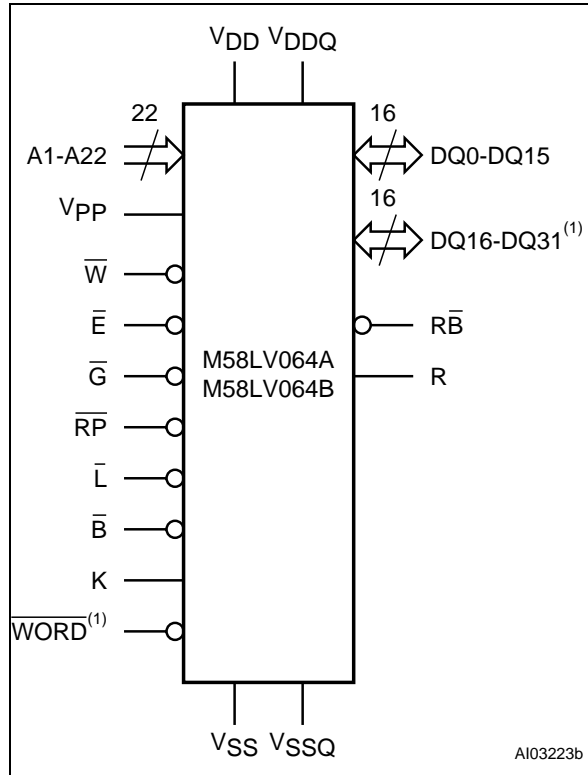

Note: 1. M58LV064B only.

Table 1. Signal Names

A1	Address Input (x16 Bus Width only)
A2-A22	Address inputs
DQ0-DQ15	Data Inputs/Outputs
DQ16-DQ31	Data Inputs/Outputs (x32 Bus Width of M58LV064B only)
\bar{B}	Burst Address Advance
\bar{E}	Chip Enable
\bar{G}	Output Enable
K	Clock
\bar{L}	Latch Enable
R	Valid Data Ready
\bar{RB}	Ready/Busy
\bar{RP}	Reset/Power-Down
VPP	Program/Erase Enable
\bar{W}	Write Enable
\overline{WORD}	Word Organization (M58LV064B only)
VDD	Supply Voltage
VDDQ	Input/Output Supply Voltage
VSS	Ground
VSSQ	Input/Output Ground
NC	Not Connected Internally

M58LV064A, M58LV064B

Figure 3. TSOP56 Connections

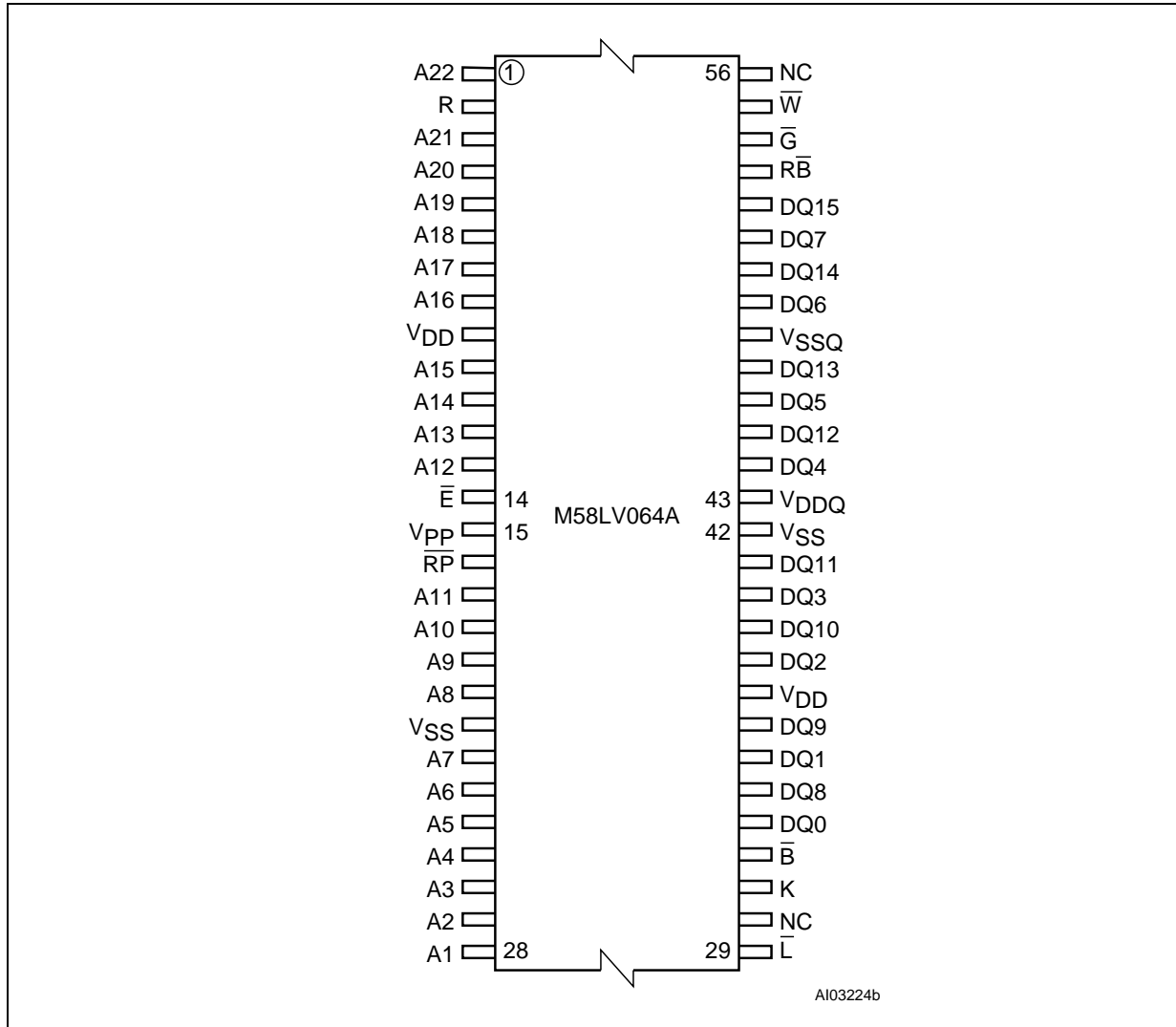
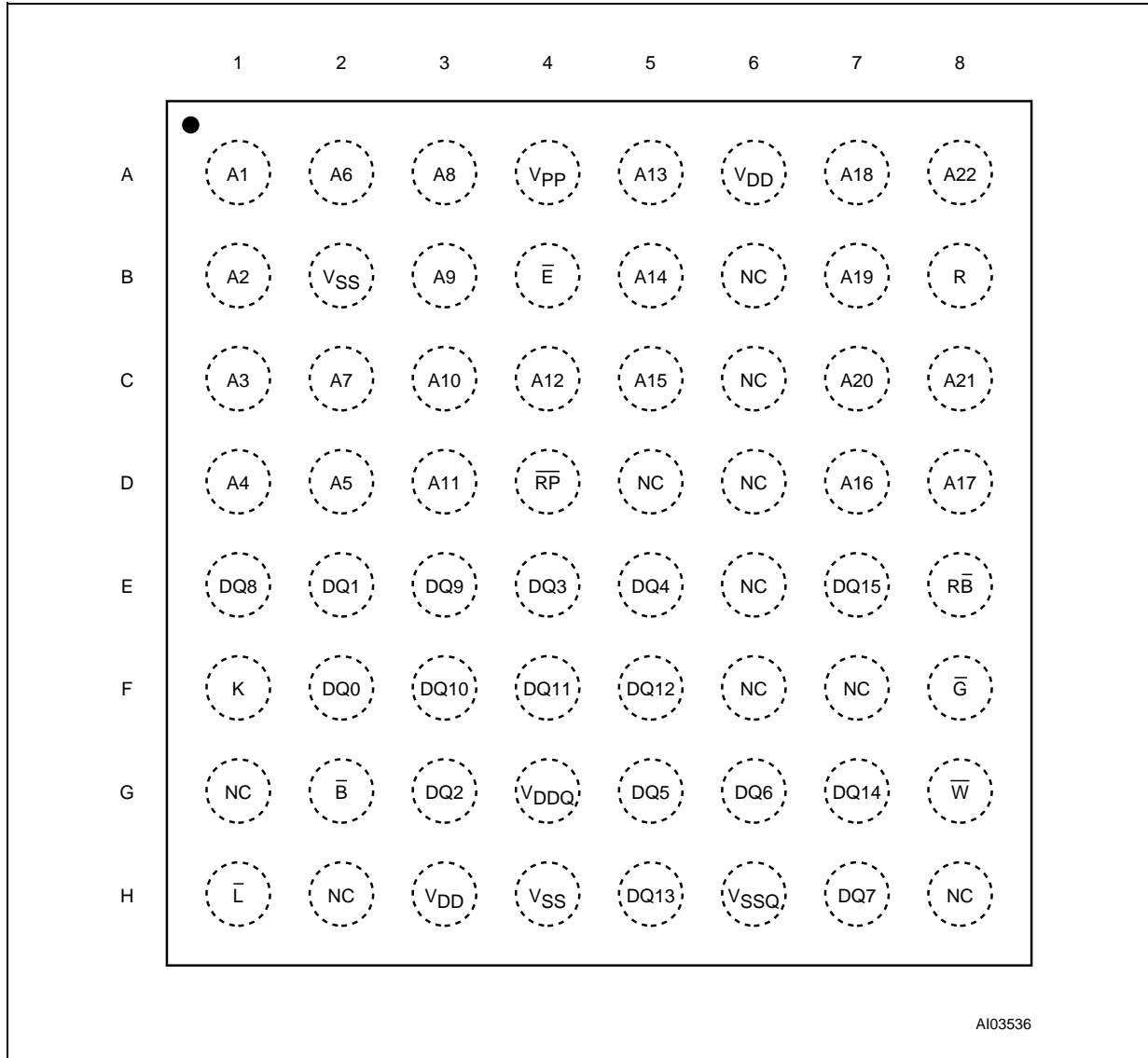

Figure 4. TBGA64 Connections for M58LV064A (Top view through package)



M58LV064A, M58LV064B

Figure 5. TBGA80 Connections for M58LV064B (Top view through package)

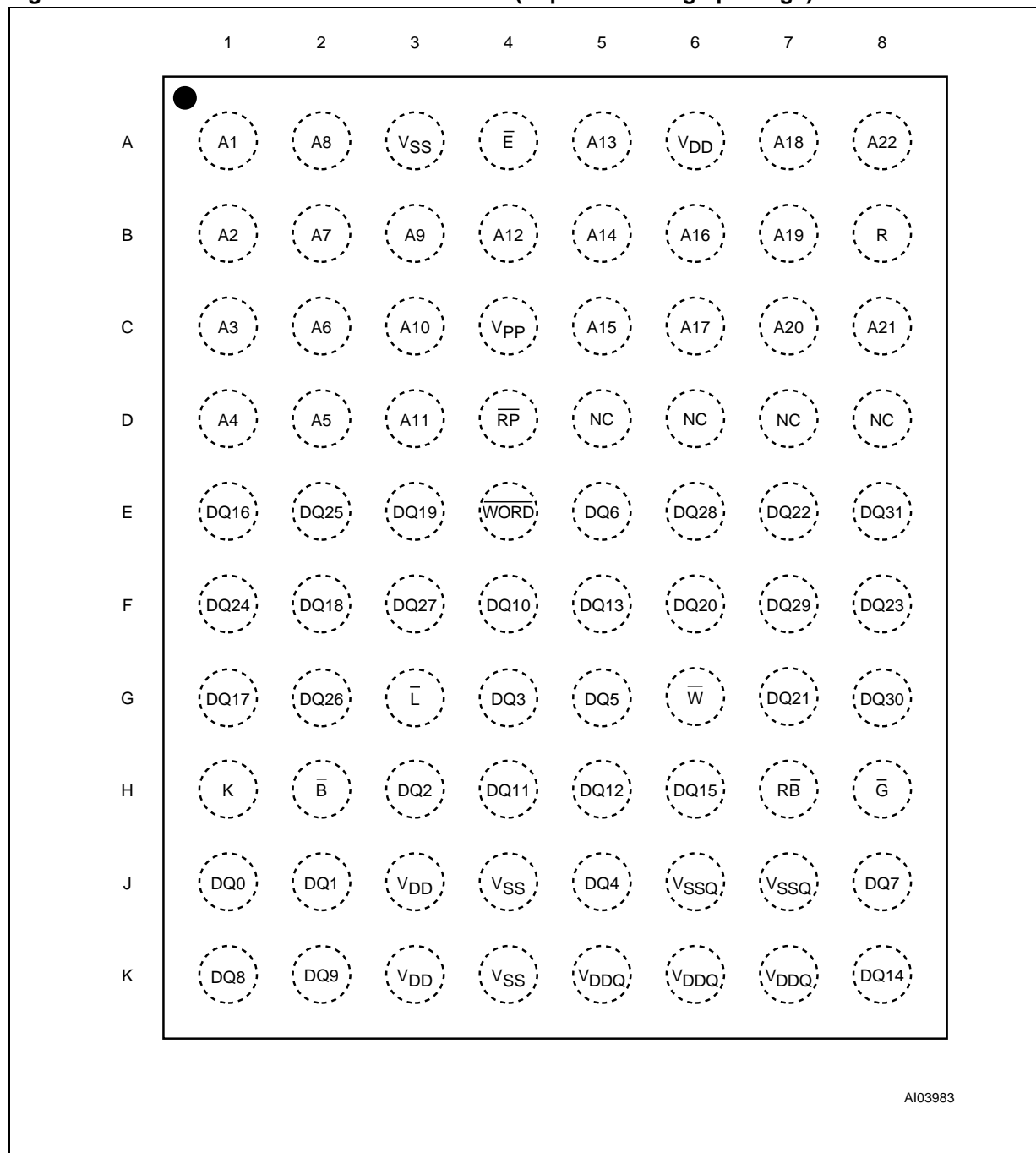
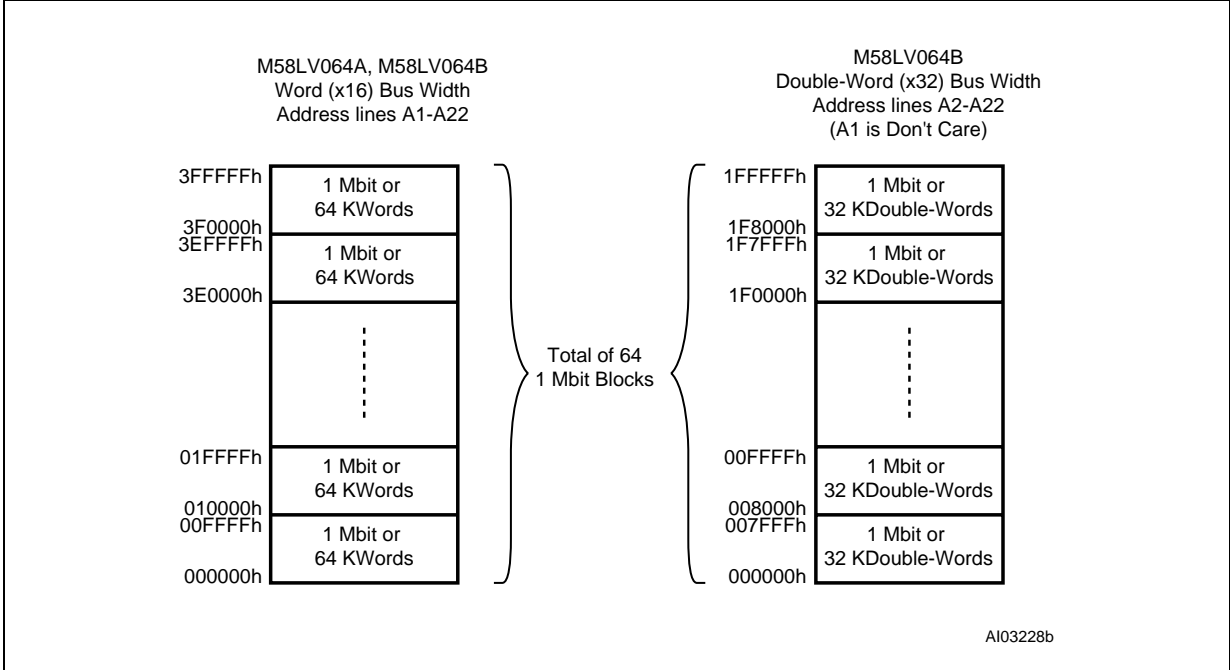

Figure 6. Block Addresses



Note: Also see Appendix A, Table 28 for a full listing of the Block Addresses

SIGNAL DESCRIPTIONS

See Figure 2, Logic Diagram and Table 1, Signal Names, for a brief overview of the signals connected to this device.

Address Inputs (A1-A22). The Address Inputs are used to select the cells to access in the memory array during Bus Read operations either to read or to program data to. During Bus Write operations they control the commands sent to the Command Interface of the internal state machine. Chip Enable must be low when selecting the addresses.

The address inputs are latched on the rising edge of Chip Enable, Write Enable or Latch Enable, whichever occurs first in a Write operation. The address latch is transparent when Latch Enable is low, V_{IL} . The address is internally latched in an Erase or Program operation.

With a x32 Bus Width, $\overline{WORD} = V_{IH}$, Address Input A1 is ignored; the Least Significant Word is output on DQ0-DQ15 and the Most Significant Word is output on DQ16-DQ31. With a x16 Bus Width, $\overline{WORD} = V_{IL}$, the Least Significant Word is output on DQ0-DQ15 when A1 is low, V_{IL} , and the Most Significant Word is output on DQ0-DQ15 when A1 is high, V_{IH} .

Data Inputs/Outputs (DQ0-DQ31). The Data Inputs/Outputs output the data stored at the selected address during a Bus Read operation, or are used to input the data during a program operation. During Bus Write operations they represent the commands sent to the Command Interface of the internal state machine. When used to input data or Write commands they are latched on the rising edge of Write Enable or Chip Enable, whichever occurs first.

When Chip Enable and Output Enable are both low, V_{IL} , the data bus outputs data from the memory array, the Electronic Signature, the Block Protection status, the CFI Information or the contents of the Status Register. The data bus is high impedance when the chip is deselected, Output Enable is High, V_{IH} , or the Reset/Power-Down signal is Low, V_{IL} . When the Program/Erase Controller is active the Ready/Busy status is given on DQ7 while DQ0-DQ6 and DQ8-DQ31 are high impedance.

With a x16 Bus Width, $\overline{WORD} = V_{IL}$, DQ16-DQ31 are not used and are high impedance.

Chip Enable (\overline{E}). The Chip Enable, \overline{E} , input activates the memory control logic, input buffers, decoders and sense amplifiers. Chip Enable, \overline{E} , at V_{IH} deselected the memory and reduces the power consumption to the Standby level, I_{DD1} .

Output Enable (\overline{G}). The Output Enable, \overline{G} , gates the outputs through the data output buffers during a read operation. When Output Enable, \overline{G} , is at V_{IH}

the outputs are high impedance. Output Enable, \overline{G} , can be used to inhibit the data output during a burst read operation.

Write Enable (\overline{W}). The Write Enable input, \overline{W} , controls writing to the Command Interface, Input Address and Data latches. Both addresses and data can be latched on the rising edge of Write Enable (also see Latch Enable, \overline{L}).

Reset/Power-Down (\overline{RP}). The Reset/Power-Down pin can be used to apply a Hardware Reset to the memory or to temporarily unprotect all blocks that have been protected.

A Hardware Reset is achieved by holding Reset/Power-Down Low, V_{IL} , for at least t_{PLPH} . When Reset/Power-Down is Low, V_{IL} , the Status Register information is cleared and the power consumption is reduced to deep power-down level. The device is deselected and outputs are high impedance. If Reset/Power-Down goes low, V_{IL} , during a Block Erase, a Write to Buffer and Program or a Block Protect/Unprotect the operation is aborted and the data may be corrupted. In this case the Ready/Busy pin stays low, V_{IL} , for a maximum timing of $t_{PLPH} + t_{PHRH}$, until the completion of the Reset/Power-Down pulse.

After Reset/Power-Down goes High, V_{IH} , the memory will be ready for Bus Read and Bus Write operations after t_{PHEL} or t_{RHEL} , whichever occurs last. Note that Ready/Busy does not fall during a reset, see Ready/Busy Output section.

During power-up Reset/Power-Down must be held Low, V_{IL} . Furthermore it must stay low for t_{VDHPH} after the Supply Voltage inputs become stable. The device will then be configured in Asynchronous Random Read mode.

See Table 23 and Figure 21, Reset, Power-Down and Power-up Characteristics, for more details.

Holding \overline{RP} at V_{HH} will temporarily unprotect the protected blocks in the memory. Program and Erase operations on all blocks will be possible.

In an application, it is recommended to associate Reset/Power-Down pin, \overline{RP} , with the reset signal of the microprocessor. Otherwise, if a reset operation occurs while the memory is performing an Erase or Program operation, the memory may output the Status Register information instead of being initialized to the default Asynchronous Random Read.

Latch Enable (\overline{L}). The Bus Interface can be configured to latch the Address Inputs on the rising edge of Latch Enable, \overline{L} . In synchronous bus operations the address is latched on the active edge of the Clock when Latch Enable is Low, V_{IL} . Once latched, the addresses may change without affecting the address used by the memory. When Latch Enable is Low, V_{IL} , the latch is transparent.

Clock (K). The Clock, K, is used to synchronize the memory with the external bus during Synchronous Bus Read operations. The Clock can be configured to have an active rising or falling edge. Bus signals are latched on the active edge of the Clock during synchronous bus operations. In Synchronous Burst Read mode the address is latched on the first active clock edge when Latch Enable is low, V_{IL} , or on the rising edge of Latch Enable, whichever occurs first.

During asynchronous bus operations the Clock is not used.

Burst Address Advance (\bar{B}). The Burst Address Advance, \bar{B} , controls the advancing of the address by the internal address counter during synchronous bus operations.

Burst Address Advance, \bar{B} , is only sampled on the active clock edge of the Clock when the X- or Y-latency time has expired. If Burst Address Advance is Low, V_{IL} , the internal address counter advances. If Burst Address Advance is High, V_{IH} , the internal address counter does not change; the same data remains on the Data Inputs/Outputs and Burst Address Advance is not sampled until the Y-latency expires.

The Burst Address Advance, \bar{B} , may be tied to V_{IL} .

Valid Data Ready (R). The Valid Data Ready output, R, is an open drain output that can be used to identify if the memory is ready to output data or not. The Valid Data Ready output is only active during Synchronous Burst Read operations when the Burst Length is set to Continuous. The Valid Data Ready output can be configured to be active on the clock edge of the invalid data read cycle or one cycle before. Valid Data Ready Low, V_{OL} , indicates that the data is not, or will not be valid. Valid Data Ready in a high-impedance state indicates that valid data is or will be available.

If the memory is configured for Synchronous Burst Read operations with Burst Length set to Continuous then the value of Valid Data Ready, will depend on the starting address. If the starting address is aligned to a four Word boundary then the continuous burst mode will run without activating the Valid Data Ready output. If the starting address is not aligned to a four Word boundary, Valid Data Ready is Low at the beginning of the continuous burst read to indicate that the memory needs an internal delay to read the content of the four successive words in the array.

Unless the Burst Length is set to Continuous and Synchronous Burst Read has been selected, Valid Data Ready is high-impedance. It may be tied to other components with the same Valid Data Ready signal to create a unique System Ready signal.

When the system clock frequency is between 33MHz and 50MHz and the Y latency is set to 2, values of \bar{B} sampled on odd clock cycles, starting from the first read are not considered.

Designers should use an external pull-up resistor of the correct value to meet the external timing requirements for Valid Data Ready rising. Refer to Figure 20.

Word Organization (\bar{WORD}). The Word Organization input, \bar{WORD} , selects the x16 or x32 Bus Width on the M58LV064B. The Word Organization input is not available on the M58LV064A.

When \bar{WORD} is Low, V_{IL} , Word-wide x16 Bus Width is selected; data is read and written to DQ0-DQ15; DQ16-DQ31 are at high impedance and A1 is the LSB of the address bus. When \bar{WORD} is High, V_{IH} , the Double-Word wide x32 Bus Width is selected and the data is read and written to on DQ0-DQ31; A2 is the LSB of the address bus and A1 is don't care.

Ready/Busy (\bar{RB}). The Ready/Busy output, \bar{RB} , is an open-drain output that can be used to identify if the Program/Erase Controller is currently active. When Ready/Busy is high impedance, the memory is ready for any Read, Program or Erase operation. Ready/Busy is Low, V_{OL} , during Program and Erase operations. When the device is busy it will not accept any additional Program or Erase commands except Program/Erase Suspend. When the Program/Erase Controller is idle, or suspended, Ready Busy can float High through a pull-up resistor.

The use of an open-drain output allows the Ready/Busy pins from several memories to be connected to a single pull-up resistor. A Low will then indicate that one, or more, of the memories is busy.

Ready/Busy is not Low during a reset unless the reset was applied when the Program/Erase Controller was active; Ready/Busy can rise before Reset/Power-Down rises.

Program/Erase Enable (V_{PP}). The Program/Erase Enable input, V_{PP} , is used to protect all blocks, preventing Program and Erase operations from affecting their data.

When Program/Erase Enable is Low, V_{IL} , any program or erase operation sent to the Command Interface will cause the V_{PP} Status bit (bit3) in the Status Register to be set. When Program/Erase Enable is High, V_{IH} , program and erase operations can be performed on unprotected blocks. Program/Erase Enable must be kept High during all Program, Erase, Block Protect and Block Unprotect operations, otherwise the operation is not guaranteed to succeed and data may become corrupt.

V_{DD} Supply Voltage. The Supply Voltage, V_{DD} , is the core power supply. All internal circuits draw

M58LV064A, M58LV064B

their current from the V_{DD} pin, including the Program/Erase Controller.

A $0.1\mu\text{F}$ capacitor should be connected between the Supply Voltage, V_{DD} , and the Ground, V_{SS} , to decouple the current surges from the power supply. The PCB track widths must be sufficient to carry the currents required during all operations of the parts, see Table 16, DC Characteristics, for maximum current supply requirements.

Input/Output Supply Voltage (V_{DDQ}). The Input/Output Supply Voltage, V_{DDQ} , is the input/output buffer power supply. All input and output pins and voltage references are powered and measured relative to the Input/Output Supply Voltage pin, V_{DDQ} .

The Input/Output Supply Voltage, V_{DDQ} , must always be equal or less than the V_{DD} Supply Voltage, including during Power-Up.

A $0.1\mu\text{F}$ capacitor should be connected between the Input/Output Supply Voltage, V_{DDQ} , and the Ground, V_{SSQ} , to decouple the current surges from the power supply. If V_{DDQ} and V_{DD} are connected together then only one decoupling capacitor is required.

Ground (V_{SS}). Ground, V_{SS} , is the reference for all core power supply voltages.

Ground (V_{SSQ}). Ground, V_{SSQ} , is the reference for input/output voltage measurements. It is essential to connect V_{SS} and V_{SSQ} to the same ground.

BUS OPERATIONS

There are 12 bus operations that control the memory. Each of these is described in this section, see Tables 2 and 3, Bus Operations, for a summary. The bus operation is selected through the Burst Configuration Register; the bits in this register are described at the end of this section.

On Power-up or after a Hardware Reset the memory defaults to Asynchronous Bus Read and Asynchronous Bus Write, no other bus operation can be performed until the Burst Control Register has been configured.

Synchronous Read operations and Latch Controlled Bus Read operations can only be used to read the memory array. The Electronic Signature, CFI or Status Register will be read in asynchronous mode regardless of the Burst Control Register settings.

Typically glitches of less than 5ns on Chip Enable or Write Enable are ignored by the memory and do not affect bus operations.

Asynchronous Bus Operations

For asynchronous bus operations refer to Table 3 together with the text below.

Asynchronous Bus Read. Asynchronous Bus Read operations read from the memory cells, or specific registers (Electronic Signature, Status Register, CFI and Block Protection Status) in the Command Interface. A valid bus operation involves setting the desired address on the Address Inputs, applying a Low signal, V_{IL} , to Chip Enable and Output Enable and keeping Write Enable High, V_{IH} . The Data Inputs/Outputs will output the value, see Figure 12, Asynchronous Bus Read AC Waveforms, and Table 17, Asynchronous Bus Read AC Characteristics, for details of when the output becomes valid.

Asynchronous Latch Controlled Bus Read.

Asynchronous Latch Controlled Bus Read operations read from the memory cells. The address is latched in the memory before the value is output on the data bus, allowing the address to change during the cycle without affecting the address that the memory uses.

A valid bus operation involves setting the desired address on the Address Inputs, setting Chip Enable and Address Latch Low, V_{IL} and keeping Write Enable High, V_{IH} ; the address is latched on the rising edge of Address Latch. Once latched, the Address Inputs can change. Set Output Enable Low, V_{IL} , to read the data on the Data Inputs/Outputs; see Figure 13, Asynchronous Latch Controlled Bus Read AC Waveforms and Table 18, Asynchronous Latch Controlled Bus Read AC Characteristics for details on when the output becomes valid.

Note that, since the Latch Enable input is transparent when set Low, V_{IL} , Asynchronous Bus Read operations can be performed when the memory is configured for Asynchronous Latch Enable bus operations by holding Latch Enable Low, V_{IL} throughout the bus operation.

Asynchronous Page Read. Asynchronous Page Read operations are used to read from several addresses within the same memory page. Each memory page is 4 Words or 2 Double-Words and has the same A3-A22, only A1 and A2 may change.

Valid bus operations are the same as Asynchronous Bus Read operations but with different timings. The first read operation within the page has identical timings, subsequent reads within the same page have much shorter access times. If the page changes then the normal, longer timings apply again. See Figure 14, Asynchronous Page Read AC Waveforms and Table 19, Asynchronous Page Read AC Characteristics for details on when the outputs become valid.

Asynchronous Bus Write. Asynchronous Bus Write operations write to the Command Interface in order to send commands to the memory or to latch addresses and input data to program. Bus Write operations are asynchronous, the clock, K, is don't care during Bus Write operations.

A valid Asynchronous Bus Write operation begins by setting the desired address on the Address Inputs and setting Latch Enable Low, V_{IL} . The Address Inputs are latched by the Command Interface on the rising edge of Chip Enable or Write Enable, whichever occurs first. The Data Inputs/Outputs are latched by the Command Interface on the rising edge of Chip Enable or Write Enable, whichever occurs first. Output Enable must remain High, V_{IH} , during the whole Asynchronous Bus Write operation. See Figures 15, and 17, Asynchronous Write AC Waveforms, and Tables 20 and 21, Asynchronous Write and Latch Controlled Write AC Characteristics, for details of the timing requirements.

Asynchronous Latch Controlled Bus Write.

Asynchronous Latch Controlled Bus Write operations write to the Command Interface in order to send commands to the memory or to latch addresses and input data to program. Bus Write operations are asynchronous, the clock, K, is don't care during Bus Write operations.

A valid Asynchronous Latch Controlled Bus Write operation begins by setting the desired address on the Address Inputs and pulsing Latch Enable Low, V_{IL} . The Address Inputs are latched by the Command Interface on the rising edge of Latch Enable, Chip Enable or Write Enable, whichever occurs

M58LV064A, M58LV064B

first. The Data Inputs/Outputs are latched by the Command Interface on the rising edge of Chip Enable or Write Enable, whichever occurs first. Output Enable must remain High, V_{IH} , during the whole Asynchronous Bus Write operation. See Figures 16 and 18 Asynchronous Latch Controlled Write AC Waveforms, and Tables 20 and 21, Asynchronous Write and Latch Controlled Write AC Characteristics, for details of the timing requirements.

Output Disable. The Data Inputs/Outputs are in the high impedance state when the Output Enable is High.

Standby. When Chip Enable is High, V_{IH} , the memory enters Standby mode and the Data Inputs/Outputs pins are placed in the high impedance state regardless of Output Enable or Write Enable. The Supply Current is reduced to the Standby Supply Current, I_{DD1} .

During Program or Erase operations the memory will continue to use the Program/Erase Supply Current, I_{DD3} , for Program or Erase operations until the operation completes.

Automatic Low Power. If there is no change in the state of the bus for a short period of time during Asynchronous Bus Read operations the memory enters Auto Low Power mode where the internal Supply Current is reduced to the Auto-Standby Supply Current, I_{DD5} . The Data Inputs/Outputs will still output data if a Bus Read operation is in progress.

Automatic Low Power is only available in Asynchronous Read modes.

Power-Down. The memory is in Power-Down mode when Reset/Power-Down, \overline{RP} , is Low. The power consumption is reduced to the Power-Down level, I_{DD2} , and the outputs are high impedance, independent of Chip Enable, Output Enable or Write Enable.

Table 2. Asynchronous Bus Operations

Bus Operation	Step	\overline{E}	\overline{G}	\overline{W}	\overline{RP}	M3 ⁽²⁾	\overline{L}	A1-A22	DQ0-DQ31
Asynchronous Bus Read		V_{IL}	V_{IL}	V_{IH}	High	0	X	Address	Data Output
Asynchronous Latch Controlled Bus Read	Address Latch	V_{IL}	V_{IL}	V_{IH}	High	1	V_{IL}	Address	High Z
	Read	V_{IL}	V_{IL}	V_{IH}	High	1	V_{IH}	X	Data Output
Asynchronous Page Read		V_{IL}	V_{IL}	V_{IH}	High	0	X	Address	Data Output
Asynchronous Bus Write		V_{IL}	V_{IH}	V_{IL}	High	X	V_{IL}	Address	Data Input
Asynchronous Latch Controlled Bus Write	Address Latch	V_{IL}	V_{IH}	V_{IL}	High	X	V_{IL}	Address	Data Input
Output Disable		V_{IL}	V_{IH}	V_{IH}	High	X	X	X	High Z
Standby		V_{IH}	X	X	High	X	X	X	High Z
Power-Down		X	X	X	V_{IL}	X	X	X	High Z

Note: 1. X = Don't Care V_{IL} or V_{IH} . High = V_{IH} or V_{HH} .

2. M15 = 1, Bits M15 and M3 are in the Burst Configuration Register.

Synchronous Bus Operations

For synchronous bus operations refer to Table 3 together with the text below.

Synchronous Burst Read. Synchronous Burst Read operations are used to read from the memory at specific times synchronized to an external reference clock. The burst type, length and latency can be configured. The different configurations for Synchronous Burst Read operations are described in the Burst Configuration Register section.

A valid Synchronous Burst Read operation begins when the address is set on the Address Inputs, Write Enable is High, V_{IH} , and Chip Enable and Latch Enable are Low, V_{IL} , during the active edge of the Clock. The address is latched on the first active clock edge when Latch Enable is low, or on the rising edge of Latch Enable, whichever occurs first. The data becomes available for output after the X-latency specified in the Burst Control Register has expired. The output buffers are activated by setting Output Enable Low, V_{IL} . See Figure 7 for an example of a Synchronous Burst Read operation.

The Burst Address Advance input and the Y-latency specified in the Burst Control Register determine whether the internal address counter is advanced on the active edge of the Clock. When the internal address counter is advanced the Data Inputs/Outputs change to output the value for the next address.

In Continuous Burst mode (Burst Length Bit M2-M0 is set to '111'), one Burst Read operation can access the entire memory sequentially and wrap at the last address. The Burst Address Advance, \bar{B} , must be kept low, V_{IL} , for the appropriate number of clock cycles. If Burst Address Advance, \bar{B} , is pulled High, V_{IH} , the Burst Read will be suspended.

In Continuous Burst Mode, if the starting address is not associated with a page (4 Word or 2 Double Word) boundary the Valid Data Ready, R, output goes Low, V_{IL} , to indicate that the data will not be ready in time and additional wait-states are required. The Valid Data Ready output timing (bit M8) can be changed in the Burst Configuration Register.

When using the x32 Bus Width certain X-latencies are not valid and must not be used; see Table 5, Burst Configuration Register.

The Synchronous Burst Read timing diagrams and AC Characteristics are described in the AC and DC Parameters section. See Figures 19, 20 and Table 22.

Synchronous Pipelined Burst Read. Synchronous Burst Read operations can be overlapped to avoid or reduce the X-latency. Pipelined operations should only be used with Burst Configuration Register bit M9 = 0 (Y-latency setting).

A valid Synchronous Pipelined Burst Read operation occurs during a Synchronous Burst Read operation when the new address is set on the Address Inputs and a Low pulse is applied to Latch Enable. The data for the new address becomes valid after the X-latency specified in the Burst Configuration Register has expired.

For optimum operation the address should be latched on the correct clock cycle. Table 4 gives the clock cycle for each valid X- and Y-latency setting. Only these settings are valid, other settings must not be used. There is always one Y-Latency period where the data is not valid. If the address is latched later than the clock cycle specified in Tables 4 then additional cycles where the data is not valid are inserted. See Figure 8 for an example of a Synchronous Pipelined Burst Read operation. Here the X-latency is 8, the Y-latency is 1 and the burst length is 4; the first address is latched on cycle 1 while the next address is latched on cycle 6, as shown in Table 4.

Synchronous Pipelined Burst Read operations should only be performed on Burst Lengths of 4 or 8 with a x16 Bus Width or a Burst Length of 4 with a x32 Bus Width.

Suspending a Pipelined Synchronous Burst Read operation is not recommended.

Synchronous Burst Read Suspend. During a Synchronous Burst Read operation it is possible to suspend the operation, freeing the data bus for other higher priority devices.

A valid Synchronous Burst Read operation is suspended when both Output Enable and Burst Address Advance are High, V_{IH} . The Burst Address Advance going High, V_{IH} , stops the burst counter and the Output Enable going High, V_{IH} , inhibits the data outputs. The Synchronous Burst Read operation can be resumed by setting Output Enable Low. See Figure 7 for an example of a Synchronous Burst Read Suspend operation.

M58LV064A, M58LV064B

Table 3. Synchronous Burst Read Bus Operations

Bus Operation	Step	\bar{E}	\bar{G}	$\bar{R}\bar{P}$	$K^{(3)}$	\bar{L}	\bar{B}	A1-A22 DQ0-DQ31
Synchronous Burst Read	Address Latch	V_{IL}	X	V_{IH}	T	V_{IL}	X	Address Input
	Read (no address advance)	V_{IL}	V_{IL}	V_{IH}	T	X	V_{IH}	Data Output
	Read (with address advance)	V_{IL}	V_{IL}	V_{IH}	T	X	V_{IL}	Data Output
	Read Suspend	V_{IL}	V_{IH}	V_{IH}	X	X	V_{IH}	High Z
Pipelined Synchronous Burst Read	Read Resume (no address advance)	V_{IL}	V_{IL}	V_{IH}	T	X	V_{IH}	Data Output
	Read Resume (with address advance)	V_{IL}	V_{IL}	V_{IH}	T	X	V_{IL}	Data Output
	Read Abort	V_{IH}	X	V_{IH}	X	X	X	High Z

Note: 1. X = Don't Care, V_{IL} or V_{IH} .

2. M15 = 0, Bit M15 is in the Burst Configuration Register.

3. T = transition, see M6 in the Burst Configuration Register for details on the active edge of K.

Table 4. Address Latch Cycle for Optimum Pipelined Synchronous Burst Read

X-Latency	Y-Latency	Address Latch Clock Cycle	
		Burst Length = 4	Burst Length = 8
8	1	6	10
9	1	7	11
12	1	10	14
13	1	11	15
15	2	11	19

Figure 7. Synchronous Burst Read Operation

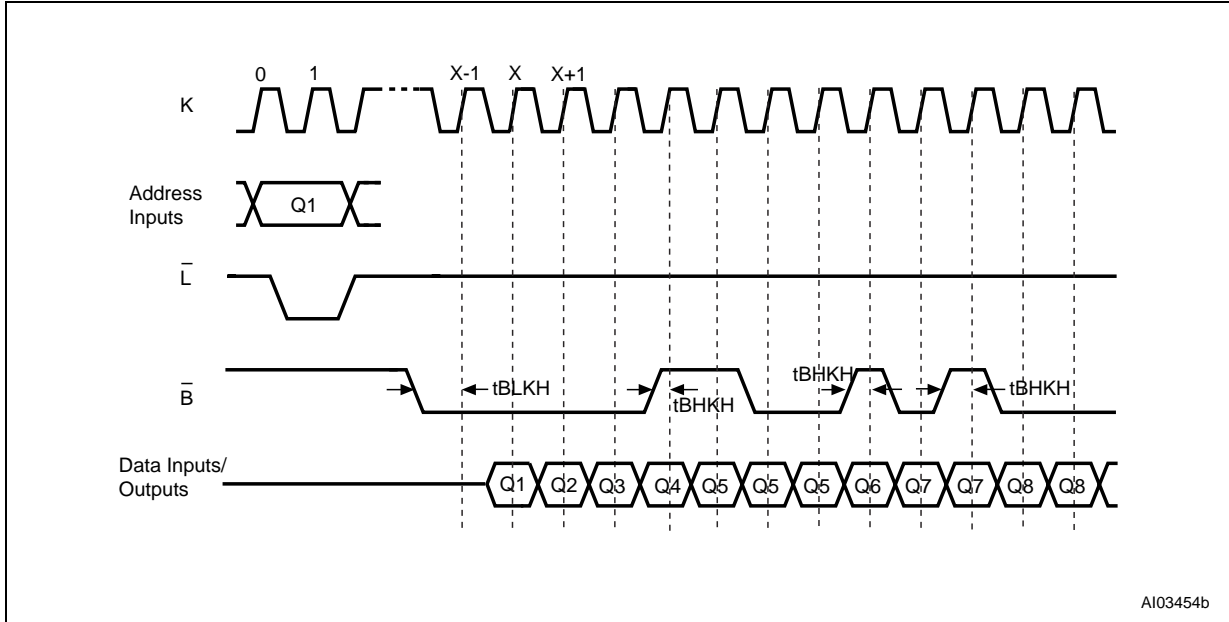

Note: In this example the Burst Configuration Register is set with M2-M0 = 001 (Burst Length = 4 Words or Double Words), M6 = 1 (Valid Clock Edge = Rising Clock Edge), M7 = 0 or 1 (Burst Type = Interleaved or Sequential), M9 = 0 (Y-Latency = 1), M14-M11 = 0011 (X-Latency = 8) and M15 = 0 (Read Select = Synchronous Burst Read), other bits are don't care.

Figure 8. Example Synchronous Pipelined Burst Read Operation

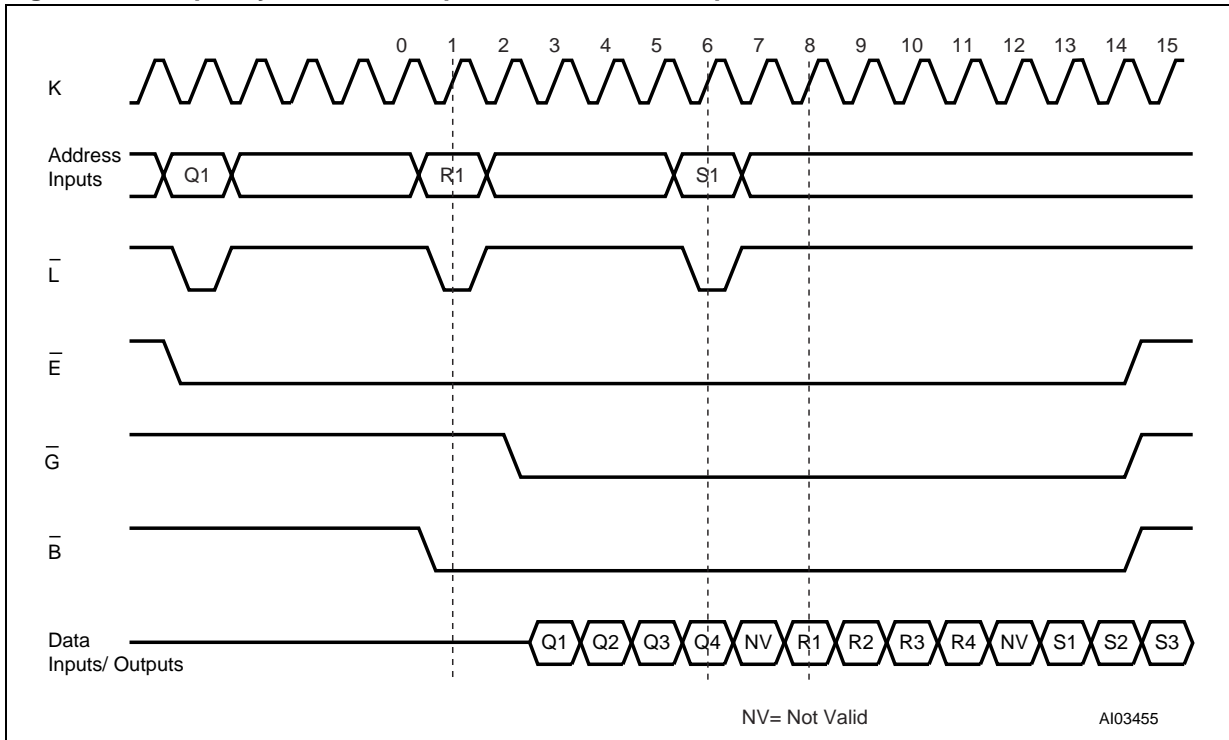

Note: In this example the Burst Configuration Register is set with M2-M0 = 001 (Burst Length = 4 Words or Double Words), M6 = 1 (Valid Clock Edge = Rising Clock Edge), M7 = 0 or 1 (Burst Type = Interleaved or Sequential), M9 = 0 (Y-Latency = 1), M14-M11 = 0011 (X-Latency = 8) and M15 = 0 (Read Select = Synchronous Burst Read), other bits are don't care.

Figure 9. Example Burst Address Advance and Burst Abort operations

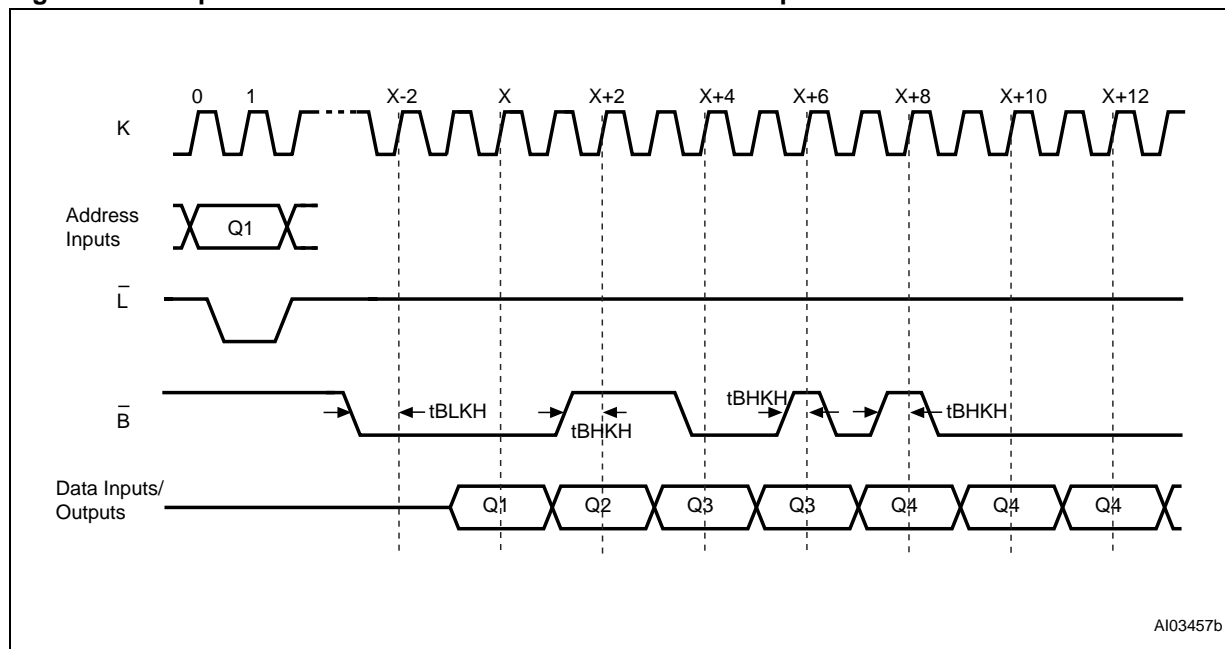

AI03457b

- Note: 1. In this example the Burst Configuration Register is set with $M2-M0 = 010$ (Burst Length = 8 Words), $M6 = 1$ (Valid Clock Edge = Rising Clock Edge), $M7 = 0$ or 1 (Burst Type = Interleaved or Sequential), $M9 = 1$ (Y-Latency = 2), $M14-M11 = 0011$ (X-Latency = 8) and $M15 = 0$ (Read Select = Synchronous Burst Read), other bits are don't care.
2. When the system clock frequency is between 33MHz and 50MHz and the Y latency is set to 2, values of \bar{B} sampled on odd clock cycles, starting from the first read are not considered.

Burst Configuration Register

The Burst Configuration Register is used to configure the type of bus access that the memory will perform.

The Burst Configuration Register is set through the Command Interface and will retain its information until it is re-configured, the device is reset, or the device goes into Reset/Power-Down mode. The Burst Configuration Register bits are described in Table 5. They specify the selection of the burst length, burst type, burst X and Y latencies and the Read operation.

Read Select Bit (M15). The Read Select bit, M15, is used to switch between asynchronous and synchronous Bus Read operations. When the Read Select bit is set to '1', Bus Read operations are asynchronous; when the Read Select bit is set to '0', Bus Read operations are synchronous.

On reset or power-up the Read Select bit is set to '1' for asynchronous accesses.

X-Latency Bits (M14-M11). The X-Latency bits are used during Synchronous Bus Read operations to set the number of clock cycles between the address being latched and the first data becoming available. For correct operation the X-Latency bits can only assume the values in Table 5, Burst Configuration Register. The X-Latency bits should also be selected in conjunction with Table 8, Burst Performance to ensure valid settings.

Y-Latency Bit (M9). The Y-Latency bit is used during Synchronous Bus Read operations to set the number of clock cycles between consecutive reads. The Y-Latency value depends on both the X-Latency value and the setting in M9.

When the Y-Latency is 1 the data changes each clock cycle; when the Y-Latency is 2 the data changes every second clock cycle. See Table 5, Burst Configuration Register and Table 8, Burst Performance, for valid combinations of the Y-Latency, the X-Latency and the Clock frequency.

Valid Data Ready Bit (M8). The Valid Data Ready bit controls the timing of the Valid Data

Ready output pin, R. When the Valid Data Ready bit is '0' the Valid Data Ready output pin is driven Low for the active clock edge when invalid data is output on the bus. When the Valid Data Ready bit is '1' the Valid Data Ready output pin is driven Low one clock cycle prior to invalid data being output on the bus.

Burst Type Bit (M7). The Burst Type bit is used to configure the sequence of addresses read as sequential or interleaved. When the Burst Type bit is '0' the memory outputs from interleaved addresses; when the Burst Type bit is '1' the memory outputs from sequential addresses. See Tables 6 and 7, Burst Type Definition, for the sequence of addresses output from a given starting address in each mode.

Valid Clock Edge Bit (M6). The Valid Clock Edge bit, M6, is used to configure the active edge of the Clock, K, during Synchronous Burst Read operations. When the Valid Clock Edge bit is '0' the falling edge of the Clock is the active edge; when the Valid Clock Edge bit is '1' the rising edge of the Clock is active.

Latch Enable Bit (M3). The Latch Enable bit is used to select between Asynchronous Random Read and Asynchronous Latch Enable Controlled Read. When the Latch Enable bit is set to '0' Random read is selected; when it is set to '1' Latch Enable Controlled Read is selected. To enable these Asynchronous Read configurations M15 must be set to '1'.

Burst Length Bit (M2-M0). The Burst Length bits set the maximum number of Words or Double-Words that can be output during a Synchronous Burst Read operation before the address wraps.

Table 5, Burst Configuration Register gives the valid combinations of the Burst Length bits that the memory accepts; Tables 6 and 7, Burst Type Definition, give the sequence of addresses output from a given starting address for each length.

M10, M5 and M4 are reserved for future use.

M58LV064A, M58LV064B

Table 5. Burst Configuration Register

Address Bit	Mnemonic	Bit Name	Reset Value	Value	Description	Valid Bus Width
17	M15	Read Select	1	0	Synchronous Burst Read	x16 or x32
				1	Asynchronous Bus Read	x16 or x32
16 to 13	M14-M11	X-Latency	XXXX	0010	X-Latency = 7, use only with Continuous Burst Length	x16 or x32
				0011	X-Latency = 8	x16 or x32
				0100	X-Latency = 9	x16 or x32
				0101	X-Latency = 10, use only with Continuous Burst Length	x16 only
				0110	X-Latency = 11, use only with Continuous Burst Length	x16 only
				1001	X-Latency = 12	x16 only
				1010	X-Latency = 13	x16 only
				1011	X-Latency = 13, use only with Continuous Burst Length	x16 or x32
				1101	X-Latency = 15	x16 or x32
				Others	Reserved, Do Not Use.	
11	M9	Y-Latency	X	0	When X-Latency < 13, Y-Latency = 1 When M14-M11 = 1011 or 1101, Y-Latency = 2	x16 or x32
				1	When X-Latency ≤ 5 but M14-M11 ≠ 1011 or 1101, Y-Latency = 2, When M14-M11 = 1011 or 1101 DO NOT USE.	x16 or x32
10	M8	Valid Data Ready	X	0	R valid Low during valid Clock edge	x16 or x32
				1	R valid Low one cycle before valid Clock edge	x16 or x32
9	M7	Burst Type	X	0	Interleaved	x16 or x32
				1	Sequential	x16 or x32
8	M6	Valid Clock Edge	X	0	Falling Clock edge	x16 or x32
				1	Rising Clock edge	x16 or x32
5	M3	Latch Enable	0	0	Random Read	x16 or x32
				1	Latch Enable Controlled Read	x16 or x32
4 to 2	M2-M0	Burst Length	XXX	100	1 Word or Double-Word	x16 or x32
				101	2 Words or Double-Words	x16 or x32
				001	4 Words or Double-Words	x16 or x32
				010	8 Words	x16 only
				111	Continuous	x16 or x32
				Others	Reserved, Do Not Use.	

Table 6. Burst Type Definition (x16 Bus Width)

Burst Length	Starting Address (binary)	Sequential (decimal)	Interleaved (decimal)
	A3 A2 A1		
2	XX0	0, 1	0, 1
	XX1	1, 0	1, 0
4	X00	0, 1, 2, 3	0, 1, 2, 3
	X01	1, 2, 3, 0	1, 0, 3, 2
	X10	2, 3, 0, 1	2, 3, 0, 1
	X11	3, 0, 1, 2	3, 2, 1, 0
8	000	0, 1, 2, 3, 4, 5, 6, 7	0, 1, 2, 3, 4, 5, 6, 7
	001	1, 2, 3, 4, 5, 6, 7, 0	1, 0, 3, 2, 5, 4, 7, 6
	010	2, 3, 4, 5, 6, 7, 0, 1	2, 3, 0, 1, 6, 7, 4, 5
	011	3, 4, 5, 6, 7, 0, 1, 2	3, 2, 1, 0, 7, 6, 5, 4
	100	4, 5, 6, 7, 0, 1, 2, 3	4, 5, 6, 7, 0, 1, 2, 3
	101	5, 6, 7, 0, 1, 2, 3, 4	5, 4, 7, 6, 1, 0, 3, 2
	110	6, 7, 0, 1, 2, 3, 4, 5	6, 7, 4, 5, 2, 3, 0, 1
	111	7, 0, 1, 2, 3, 4, 5, 6	7, 6, 5, 4, 3, 2, 1, 0
Continuous	A	A, A+1, A+2...	Not Valid

Note: X = 0 or 1.

Table 7. Burst Type Definition (x32 Bus Width)

Burst Length	Starting Address (binary)	Sequential (decimal)	Interleaved (decimal)
	A3 A2		
2	X0	0, 1	0, 1
	X1	1, 0	1, 0
4	00	0, 1, 2, 3	0, 1, 2, 3
	01	1, 2, 3, 0	1, 0, 3, 2
	10	2, 3, 0, 1	2, 3, 0, 1
	11	3, 0, 1, 2	3, 2, 1, 0
8	Not Valid		
Continuous	A	A, A+1, A+2...	Not Valid

Note: X = 0 or 1.

M58LV064A, M58LV064B

Table 8. Burst Performance

X-Latency	Y-Latency	Bus Width	Clock Frequency	Mode
7	1	x16, x32	≤ 33 MHz	continuous only
8				continuous, length
9				continuous only
7	2			continuous only
8				continuous, length
9				continuous, length
10	1	x16 only	≤ 50 MHz	continuous only
11				continuous, length
12				continuous, length
13	2			continuous only
10				continuous only
11				continuous, length
12		continuous, length		
13	2(M9=0)	x16, x32	≤ 66 MHz	continuous only
15				continuous, length

COMMAND INTERFACE

All Bus Write operations to the memory are interpreted by the Command Interface. Commands consist of one or more sequential Bus Write operations. The Commands are summarized in Table 9, Commands. Refer to Table 9 in conjunction with the text descriptions below.

After power-up or a Reset operation the memory enters Read mode.

Synchronous Read operations and Latch Controlled Bus Read operations can only be used to read the memory array. The Electronic Signature, CFI or Status Register will be read in asynchronous mode regardless of the Burst Control Register settings. Once the memory returns to Read Memory Array mode the bus will resume the setting in the Burst Configuration Register automatically.

Read Memory Array Command. The Read Memory Array command returns the memory to Read mode. One Bus Write cycle is required to issue the Read Memory Array command and return the memory to Read mode. Once the command is issued the memory remains in Read mode until another command is issued. From Read mode Bus Read commands will access the memory array.

While the Program/Erase Controller is executing a Program, Erase, Block Protect or Blocks Unprotect operation the memory will not accept the Read Memory Array command until the operation completes.

Read Electronic Signature Command. The Read Electronic Signature command is used to read the Manufacturer Code, the Device Code and the Block Protection Status. One Bus Write cycle is required to issue the Read Electronic Signature command. Once the command is issued subsequent Bus Read operations read the Manufacturer Code, the Device Code or the Block Protection Status until another command is issued; see Table 10, Read Electronic Signature.

Read Query Command. The Read Query Command is used to read data from the Common Flash Interface (CFI) Memory Area. One Bus Write cycle is required to issue the Read Query Command. Once the command is issued subsequent Bus Read operations read from the Common Flash Interface Memory Area. See Appendix B, Tables 29, 30, 31, 32, 33 and 34 for details on the information contained in the Common Flash Interface (CFI) memory area.

Note that the addresses for the Common Flash Interface Memory Area are A1-A22 for the M58LV064A and A2-A22 for the M58LV064B, regardless of the Bus Width selected.

Read Status Register Command. The Read Status Register command is used to read the Status

Register. One Bus Write cycle is required to issue the Read Status Register command. Once the command is issued subsequent Bus Read operations read the Status Register until another command is issued.

The Status Register information is present on the output data bus (DQ1-DQ7) when both Chip Enable and Output Enable are low, V_{IL} .

See the section on the Status Register and Table 12 for details on the definitions of the Status Register bits

Clear Status Register Command. The Clear Status Register command can be used to reset bits 1, 3, 4 and 5 in the Status Register to '0'. One Bus Write is required to issue the Clear Status Register command.

The bits in the Status Register are sticky and do not automatically return to '0' when a new Write to Buffer and Program, Erase, Block Protect or Block Unprotect command is issued. If any error occurs then it is essential to clear any error bits in the Status Register by issuing the Clear Status Register command before attempting a new Program, Erase or Resume command.

Block Erase Command. The Block Erase command can be used to erase a block. It sets all of the bits in the block to '1'. All previous data in the block is lost. If the block is protected then the Erase operation will abort, the data in the block will not be changed and the Status Register will output the error.

Two Bus Write operations are required to issue the command; the second Bus Write cycle latches the block address in the internal state machine and starts the Program/Erase Controller. Once the command is issued subsequent Bus Read operations read the Status Register. See the section on the Status Register for details on the definitions of the Status Register bits.

During the Erase operation the memory will only accept the Read Status Register command and the Program/Erase Suspend command. All other commands will be ignored. Typical Erase times are given in Table 11.

See Appendix C, Figure 27, Block Erase Flowchart and Pseudo Code, for a suggested flowchart on using the Block Erase command.

Write to Buffer and Program Command. The Write to Buffer and Program command is used to program the memory array.

Up to 4 pages of 4 Words (or 2 Double Words) can be loaded into the Write Buffer and programmed into the memory. The 4 pages are selected by addresses A3 and A4; each page has the same A3-A22.

M58LV064A, M58LV064B

Four successive steps are required to issue the command.

1. One Bus Write operation is required to set up the Write to Buffer and Program Command. Issue the set up command with the selected memory Block Address where the program operation should occur (any address in the block where the values will be programmed can be used). Any Bus Read operations will start to output the Status Register after the 1st cycle.
2. Use one Bus Write operation to write the same block address along with the value N on the Data Inputs/Output, where N+1 is the number of Words (x16 Bus Width) or Double Words (x32 Bus Width) to be programmed.
3. Use N+1 Bus Write operations to load the address and data for each Word or Double Word into the Write Buffer. See the constraints on the address combinations listed below. The addresses must have the same A5-A22.
4. Finally, use one Bus Write operation to issue the final cycle to confirm the command and start the Program operation.

Invalid address combinations or failing to follow the correct sequence of Bus Write cycles will set an error in the Status Register and abort the operation without affecting the data in the memory array. The Status Register should be cleared before re-issuing the command.

The minimum buffer size for a program operation is a 4 Word (or 2 Double Word) page. Inside the page the 4 Words are selected by addresses A2 and A1. Any attempt to program a single word (or Double Word) inside the page of a previously erased block will result in the programming of the Word, however all other Words inside the page will be set to FFFFh.

For any page, only one Write to Buffer and Program Command can be issued inside a previously erased block. Any further Program operations on that page must be preceded by an Erase operation on the respective block.

If the block being programmed is protected an error will be set in the Status Register and the operation will abort without affecting the data in the memory array. The block must be unprotected using the Blocks Unprotect command or by using the Blocks Temporary Unprotect feature of the Reset/Power-Down pin, RP.

See Appendix C, Figure 25, Write to Buffer and Program Flowchart and Pseudo Code, for a suggested flowchart on using the Write to Buffer and Program command.

Program/Erase Suspend Command. The Program/Erase Suspend command is used to pause a Write to Buffer and Program or Erase operation.

The command will only be accepted during a Program or an Erase operation. It can be issued at any time during an Erase operation but will only be accepted during a Write to Buffer and Program command if the Program/Erase Controller is running.

One Bus Write cycle is required to issue the Program/Erase Suspend command and pause the Program/Erase Controller. Once the command is issued it is necessary to poll the Program/Erase Controller Status bit (bit 7) to find out when the Program/Erase Controller has paused; no other commands will be accepted until the Program/Erase Controller has paused. After the Program/Erase Controller has paused, the memory will continue to output the Status Register until another command is issued.

During the polling period between issuing the Program/Erase Suspend command and the Program/Erase Controller pausing it is possible for the operation to complete. Once the Program/Erase Controller Status bit (bit 7) indicates that the Program/Erase Controller is no longer active, the Program Suspend Status bit (bit 2) or the Erase Suspend Status bit (bit 6) can be used to determine if the operation has completed or is suspended. For timing on the delay between issuing the Program/Erase Suspend command and the Program/Erase Controller pausing see Table 11.

During Program/Erase Suspend the Read Memory Array, Read Status Register, Read Electronic Signature, Read Query and Program/Erase Resume commands will be accepted by the Command Interface. Additionally, if the suspended operation was Erase then the Write to Buffer and Program, and the Program Suspend commands will also be accepted. When a program operation is completed inside a Block Erase Suspend the Read Memory Array command must be issued to reset the device in Read mode, then the Erase Resume command can be issued to complete the whole sequence. Only the blocks not being erased may be read or programmed correctly.

See Appendix C, Figure 26, Program Suspend & Resume Flowchart and Pseudo Code, and Figure 28, Erase Suspend & Resume Flowchart and Pseudo Code, for suggested flowcharts on using the Program/Erase Suspend command.

Program/Erase Resume Command. The Program/Erase Resume command can be used to restart the Program/Erase Controller after a Program/Erase Suspend operation has paused it. One Bus Write cycle is required to issue the Program/Erase Resume command. Once the command is issued subsequent Bus Read operations read the Status Register.

Set Burst Configuration Register Command.

The Set Burst Configuration Register command is used to write a new value to the Burst Configuration Control Register which defines the burst length, type, X and Y latencies, Synchronous/Asynchronous Read mode and the valid Clock edge configuration.

Two Bus Write cycles are required to issue the Set Burst Configuration Register command. Once the command is issued the memory returns to Read mode as if a Read Memory Array command had been issued.

The value for the Burst Configuration Register is always presented on A2-A17, regardless of the bus width that is selected. M0 is on A2, M1 on A3, etc.; the other address bits are ignored.

Block Protect Command. The Block Protect command is used to protect a block and prevent Program or Erase operations from changing the data in it. Two Bus Write cycles are required to issue the Block Protect command; the second Bus Write cycle latches the block address in the internal state machine and starts the Program/Erase Controller. Once the command is issued subsequent Bus Read operations read the Status Register. See the section on the Status Register for

details on the definitions of the Status Register bits.

During the Block Protect operation the memory will only accept the Read Status Register command. All other commands will be ignored. Typical Block Protection times are given in Table 11.

The Block Protection bits are non-volatile, once set they remain set through reset and power-down/power-up. They are cleared by a Blocks Unprotect command or temporarily disabled by raising the Reset/Power-Down pin to V_{HH} and holding it at that level throughout a Block Erase or Write to Buffer and Program command.

Blocks Unprotect Command. The Blocks Unprotect command is used to unprotect all of the blocks. Two Bus Write cycles are required to issue the Blocks Unprotect command; the second Bus Write cycle starts the Program/Erase Controller. Once the command is issued subsequent Bus Read operations read the Status Register. See the section on the Status Register for details on the definitions of the Status Register bits.

During the Block Unprotect operation the memory will only accept the Read Status Register command. All other commands will be ignored. Typical Block Protection times are given in Table 11.

M58LV064A, M58LV064B

Table 9. Commands

Command	Cycles	Bus Write Operations							
		1st		2nd		Subsequent		Final	
		Addr	Data	Addr	Data	Addr	Data	Addr	Data
Read Memory Array	1	X	FFh						
Read Electronic Signature	1	X	90h						
Read Query	1	X	98h						
Read Status Register	1	X	70h						
Clear Status Register	1	X	50h						
Block Erase	2	X	20h	BA	D0h				
Write to Buffer and Program	4 + N	BA	E8h	BA	N	PA	PD	X	D0h
Program/Erase Suspend	1	X	B0h						
Program/Erase Resume	1	X	D0h						
Set Burst Configuration Register	2	BCR	60h	BCR	03h				
Block Protect	2	BA	60h	BA	01h				
Blocks Unprotect	2	X	60h	X	D0h				

Note: X Don't Care; PA Program Address; PD Program Data; BA Any address in the Block; N+1 Number of Addresses to Program; BCR Burst Configuration Register value.

Table 10. Read Electronic Signature

Code	Bus Width ⁽³⁾	Address ⁽⁴⁾	Data (DQ31-DQ0) ⁽²⁾
Manufacturer Code	x16	000000h	0020h
	x32		00000020h
Device Code	x16	000001h	0015h (M58LV064A) 0014h (M58LV064B)
	x32		00000014h (M58LV064B)
Block Protection Status	x16	SBA ⁽¹⁾ +02h	0000h (Block Unprotected) 0001h (Block Protected)
	x32		00000000h (Block Unprotected) 00000001h (Block Protected)

Note: 1. SBA is the Start Base Address of each block.
 2. DQ31-DQ16 are available in the M58LV064B only.
 3. x32 Bus Width is available in the M58LV064B only.
 4. The address is presented on A22-A2 in x32 mode, and on A22-A1 in x16 mode.

Table 11. Program, Erase Times and Program Erase Endurance Cycles

Parameters	M58LV064A/B				Unit
	Min	Typ	Typical after 100k W/E Cycles	Max	
Block (1Mb) Erase		0.75	0.75	5	s
Chip Program		54	54		s
Program Write Buffer		192	192		μs
Program Suspend Latency Time		3		10	μs
Erase Suspend Latency Time		10		30	μs
Block Protect Time		192			μs
Blocks Unprotect Time		0.75			s
Program/Erase Cycles (per Block)	100,000				cycles
Data Retention	20				years

Note: ($T_A = 0$ to 70°C ; $V_{DD} = 2.7\text{V}$ to 3.6V ; $V_{DDQ} = 1.8\text{V}$)

STATUS REGISTER

The Status Register provides information on the current or previous Program, Erase, Block Protect or Blocks Unprotect operation. The various bits in the Status Register convey information and errors on the operation. They are output on DQ7-DQ0.

To read the Status Register the Read Status Register command can be issued. The Status Register is automatically read after Program, Erase, Block Protect, Blocks Unprotect and Program/Erase Resume commands. The Status Register can be read from any address.

The Status Register can only be read using Asynchronous Bus Read operations. Once the memory returns to Read Memory Array mode the bus will resume the setting in the Burst Configuration Register automatically.

The contents of the Status Register can be updated during an Erase or Program operation by toggling the Output Enable pin or by dis-activating (Chip Enable, V_{IH}) and then reactivating (Chip Enable and Output Enable, V_{IL}) the device.

Status Register bits 5, 4, 3 and 1 are associated with various error conditions and can only be reset with the Clear Status Register command. The Status Register bits are summarized in Table 12, Status Register Bits. Refer to Table 12 in conjunction with the following text descriptions.

Program/Erase Controller Status (Bit 7). The Program/Erase Controller Status bit indicates whether the Program/Erase Controller is active or inactive. When the Program/Erase Controller Status bit is Low, V_{OL} , the Program/Erase Controller is active and all other Status Register bits are High Impedance; when the bit is High, V_{OH} , the Program/Erase Controller is inactive.

The Program/Erase Controller Status is Low immediately after a Program/Erase Suspend command is issued until the Program/Erase Controller pauses. After the Program/Erase Controller pauses the bit is High.

During Program, Erase, Block Protect and Blocks Unprotect operations the Program/Erase Controller Status bit can be polled to find the end of the operation. The other bits in the Status Register should not be tested until the Program/Erase Controller completes the operation and the bit is High.

After the Program/Erase Controller completes its operation the Erase Status, Program Status and Block Protection Status bits should be tested for errors.

Erase Suspend Status (Bit 6). The Erase Suspend Status bit indicates that an Erase operation has been suspended and is waiting to be resumed. The Erase Suspend Status should only be considered valid when the Program/Erase Controller Status bit is High (Program/Erase Controller

inactive); after a Program/Erase Suspend command is issued the memory may still complete the operation rather than entering the Suspend mode.

When the Erase Suspend Status bit is Low, V_{OL} , the Program/Erase Controller is active or has completed its operation; when the bit is High, V_{OH} , a Program/Erase Suspend command has been issued and the memory is waiting for a Program/Erase Resume command.

When a Program/Erase Resume command is issued the Erase Suspend Status bit returns Low.

Erase Status (Bit 5). The Erase Status bit can be used to identify if the memory has failed to verify that the block has erased correctly or that all blocks have been unprotected successfully. The Erase Status bit should be read once the Program/Erase Controller Status bit is High (Program/Erase Controller inactive).

When the Erase Status bit is Low, V_{OL} , the memory has successfully verified that the block has erased correctly or all blocks have been unprotected successfully. When the Erase Status bit is High, V_{OH} , the erase operation has failed. Depending on the cause of the failure other Status Register bits may also be set to High, V_{OH} .

- If only the Erase Status bit (bit 5) is set High, V_{OH} , then the Program/Erase Controller has applied the maximum number of pulses to the block and still failed to verify that the block has erased correctly or that all the blocks have been unprotected successfully.
- If the failure is due to an erase or blocks unprotect with V_{PP} low, V_{OL} , then V_{PP} Status bit (bit 3) is also set High, V_{OH} .
- If the failure is due to an erase on a protected block then Block Protection Status bit (bit 1) is also set High, V_{OH} .
- If the failure is due to a program or erase incorrect command sequence then Program Status bit (bit 4) is also set High, V_{OH} .

Once set High, the Erase Status bit can only be reset Low by a Clear Status Register command or a hardware reset. If set High it should be reset before a new Program or Erase command is issued, otherwise the new command will appear to fail.

Program Status (Bit 4). The Program Status bit is used to identify a Program or Block Protect failure. The Program Status bit should be read once the Program/Erase Controller Status bit is High (Program/Erase Controller inactive).

When the Program Status bit is Low, V_{OL} , the memory has successfully verified that the Write Buffer has programmed correctly or the block is protected. When the Program Status bit is High, V_{OH} , the program or block protect operation has

failed. Depending on the cause of the failure other Status Register bits may also be set to High, V_{OH} .

- If only the Program Status bit (bit 4) is set High, V_{OH} , then the Program/Erase Controller has applied the maximum number of pulses to the byte and still failed to verify that the Write Buffer has programmed correctly or that the Block is protected.
- If the failure is due to a program or block protect with V_{PP} low, V_{OL} , then V_{PP} Status bit (bit 3) is also set High, V_{OH} .
- If the failure is due to a program on a protected block then Block Protection Status bit (bit 1) is also set High, V_{OH} .
- If the failure is due to a program or erase incorrect command sequence then Erase Status bit (bit 5) is also set High, V_{OH} .

Once set High, the Program Status bit can only be reset Low by a Clear Status Register command or a hardware reset. If set High it should be reset before a new Program or Erase command is issued, otherwise the new command will appear to fail.

V_{PP} Status (Bit 3). The V_{PP} Status bit can be used to identify if a Program, Erase, Block Protection or Block Unprotection operation has been attempted when V_{PP} is Low, V_{IL} . The V_{PP} pin is only sampled at the beginning of a Program or Erase operation.

When the V_{PP} Status bit is Low, V_{OL} , no Program, Erase, Block Protection or Block Unprotection operations have been attempted with V_{PP} Low, V_{IL} , since the last Clear Status Register command, or hardware reset. When the V_{PP} Status bit is High, V_{OH} , a Program, Erase, Block Protection or Block Unprotection operation has been attempted with V_{PP} Low, V_{IL} .

Once set High, the V_{PP} Status bit can only be reset by a Clear Status Register command or a hardware reset. If set High it should be reset before a new Program, Erase, Block Protection or Block

Unprotection command is issued, otherwise the new command will appear to fail.

Program Suspend Status (Bit 2). The Program Suspend Status bit indicates that a Program operation has been suspended and is waiting to be resumed. The Program Suspend Status should only be considered valid when the Program/Erase Controller Status bit is High (Program/Erase Controller inactive); after a Program/Erase Suspend command is issued the memory may still complete the operation rather than entering the Suspend mode.

When the Program Suspend Status bit is Low, V_{OL} , the Program/Erase Controller is active or has completed its operation; when the bit is High, V_{OH} , a Program/Erase Suspend command has been issued and the memory is waiting for a Program/Erase Resume command.

When a Program/Erase Resume command is issued the Program Suspend Status bit returns Low.

Block Protection Status (Bit 1). The Block Protection Status bit can be used to identify if a Program or Erase operation has tried to modify the contents of a protected block.

When the Block Protection Status bit is Low, V_{OL} , no Program or Erase operations have been attempted to protected blocks since the last Clear Status Register command or hardware reset; when the Block Protection Status bit is High, V_{OH} , a Program (Program Status bit 4 set High) or Erase (Erase Status bit 5 set High) operation has been attempted on a protected block.

Once set High, the Block Protection Status bit can only be reset Low by a Clear Status Register command or a hardware reset. If set High it should be reset before a new Program or Erase command is issued, otherwise the new command will appear to fail.

Reserved (Bit 0). Bit 0 of the Status Register is reserved. Its value should be masked.

M58LV064A, M58LV064B

Table 12. Status Register Bits

Operation	Bit 7	Bit 6	Bit 5	Bit 4	Bit 3	Bit 2	Bit 1	R \bar{B}
Program/Erase Controller Active	'0'	Hi-Z						V _{OL}
Write Buffer not ready	'0'	Hi-Z						V _{OL}
Write Buffer ready	'1'	X ⁽¹⁾	'0'	'0'	'0'	'0'	'0'	Hi-Z
Program suspended	'1'	X ⁽¹⁾	'0'	'0'	'0'	'1'	'0'	Hi-Z
Program/Block Protect completed successfully	'1'	X ⁽¹⁾	'0'	'0'	'0'	'0'	'0'	Hi-Z
Program/Block Protect failure due to incorrect command sequence	'1'	X ⁽¹⁾	'1'	'1'	'0'	'0'	'0'	Hi-Z
Program/Block Protect failure due to V _{PP} Error	'1'	X ⁽¹⁾	'0'	'1'	'1'	'0'	'0'	Hi-Z
Program failure due to Block Protection	'1'	X ⁽¹⁾	'0'	'1'	'0'	'0'	'1'	Hi-Z
Program/Block Protect failure due cell failure or unerasable cell	'1'	X ⁽¹⁾	'0'	'1'	'0'	'0'	'0'	Hi-Z
Erase suspended	'1'	'1'	'0'	'0'	'0'	'0'	'0'	Hi-Z
Erase/Blocks Unprotect completed successfully	'1'	'0'	'0'	'0'	'0'	'0'	'0'	Hi-Z
Erase/Blocks Unprotect failure due to incorrect command sequence	'1'	X	'1'	'1'	'0'	'0'	'0'	Hi-Z
Erase/Block Unprotect failure due to V _{PP} Error	'1'	'0'	'1'	'0'	'1'	'0'	'0'	Hi-Z
Erase failure due to Block Protection	'1'	'0'	'1'	'0'	'0'	'0'	'1'	Hi-Z
Erase/Blocks Unprotect failure due to failed cell(s) in block	'1'	'0'	'1'	'0'	'0'	'0'	'0'	Hi-Z

Note: 1. For Program operations during Erase Suspend Bit 6 is '1', otherwise Bit 6 is '0'.

MAXIMUM RATING

Stressing the device above the ratings listed in Table 13, Absolute Maximum Ratings, may cause permanent damage to the device. These are stress ratings only and operation of the device at these or any other conditions above those indicated in the Operating sections of this specification is

not implied. Exposure to Absolute Maximum Rating conditions for extended periods may affect device reliability. Refer also to the STMicroelectronics SURE Program and other relevant quality documents.

Table 13. Absolute Maximum Ratings

Symbol	Parameter	Value		Unit
		Min	Max	
T _{BIAS}	Temperature Under Bias	-40	125	°C
T _{STG}	Storage Temperature	-55	150	°C
T _{LEAD}	Maximum TLEAD Temperature during soldering		t.b.a.	°C
V _{IO}	Input or Output Voltage	-0.6	V _{DDQ} +0.6	V
V _{DD} , V _{DDQ}	Supply Voltage	-0.6	5.0	V
V _{HH}	\overline{RP} Hardware Block Unprotect Voltage	-0.6	10 ⁽¹⁾	V

Note: 1. Cumulative time at a high voltage level of 10V should not exceed 80 hours on \overline{RP} pin.

M58LV064A, M58LV064B

DC AND AC PARAMETERS

This section summarizes the operating and measurement conditions, and the DC and AC characteristics of the device. The parameters in the DC and AC characteristics Tables that follow, are derived from tests performed under the Measure-

ment Conditions summarized in Table 14, Operating and AC Measurement Conditions. Designers should check that the operating conditions in their circuit match the measurement conditions when relying on the quoted parameters.

Table 14. Operating and AC Measurement Conditions

Parameter	M58LV064		Units	
	Min	Max		
Supply Voltage (V_{DD}) M58LV064	3.0	3.6	V	
Input/Output Supply Voltage (V_{DDQ})	1.8	V_{DD}	V	
Ambient Temperature (T_A)	Grade 1	0	70	°C
	Grade 6	-40	85	°C
Load Capacitance (C_L)	30		pF	
Clock Rise and Fall Times		3	ns	
Input Rise and Fall Times		4	ns	
Input Pulses Voltages	0 to V_{DDQ}		V	
Input and Output Timing Ref. Voltages	0.5 V_{DDQ}		V	

Figure 10. AC Measurement Input Output Waveform

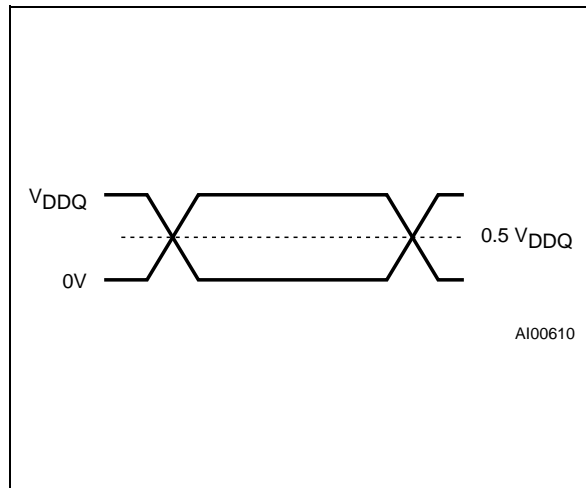

Figure 11. AC Measurement Load Circuit

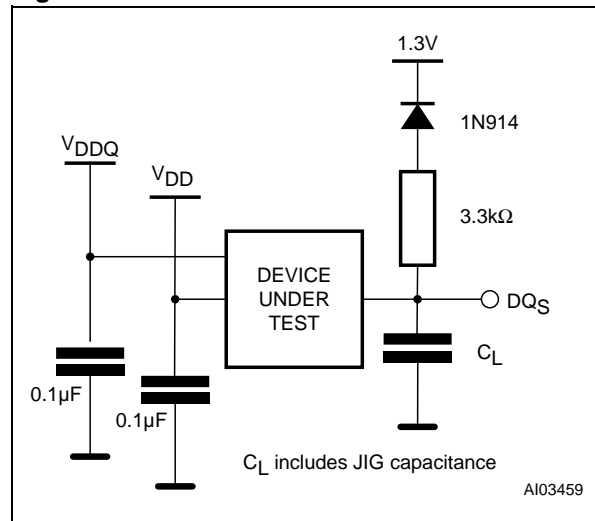

Table 15. Capacitance

Symbol	Parameter	Test Condition	Typ	Max	Unit
C_{IN}	Input Capacitance	$V_{IN} = 0V$	6	8	pF
C_{OUT}	Output Capacitance	$V_{OUT} = 0V$	8	12	pF

Note: 1. $T_A = 25^\circ\text{C}$, $f = 1\text{ MHz}$
 2. Sampled only, not 100% tested.

Table 16. DC Characteristics

Symbol	Parameter	Test Condition	Min	Max	Unit
I_{LI}	Input Leakage Current	$0V \leq V_{IN} \leq V_{DDQ}$		± 1	μA
I_{LO}	Output Leakage Current	$0V \leq V_{OUT} \neq V_{DDQ}$		± 5	μA
I_{DD}	Supply Current (Random Read)	$\bar{E} = V_{IL}, \bar{G} = V_{IH}, f_{add} = 6MHz$		30	mA
I_{DDB}	Supply Current (Burst Read)	$\bar{E} = V_{IL}, \bar{G} = V_{IH}, f_{clock} = 50MHz$		50	mA
I_{DD1}	Supply Current (Standby)	$\bar{E} = V_{IH}, \bar{RP} = V_{IH}$		40	μA
I_{DD5}	Supply Current (Auto Low-Power)	$\bar{E} = V_{IL}, \bar{RP} = V_{IH}$		2	mA
I_{DD2}	Supply Current (Reset/Power-Down)	$\bar{RP} = V_{IL}$		1	μA
I_{DD3}	Supply Current (Program or Erase, Set Block Protection, Unprotection)	Program or Erase operation in progress		50	mA
I_{DD4}	Supply Current (Erase/Program Suspend)	$\bar{E} = V_{IH}$		50	mA
V_{IL}	Input Low Voltage		-0.5	0.8	V
V_{IH}	Input High Voltage		$V_{DDQ} - 0.8$	$V_{DDQ} + 0.5$	V
V_{OL}	Output Low Voltage	$I_{OL} = 100\mu A$		0.1	V
V_{OH}	Output High Voltage	$I_{OH} = -100\mu A$	$V_{DDQ} - 0.1$		V
$V_{HH}^{(1)}$	\bar{RP} Hardware Block Unprotect Voltage	Block Erase in progress, Write to Buffer and Program	8.5	9.5	V
I_{HH}	\bar{RP} Hardware Block Unprotect Current	$\bar{RP} = V_{HH}$		1	μA
V_{LKO}	V_{DD} Supply Voltage (Erase and Program lockout)			2.2	V

Note: 1. Biasing \bar{RP} pin to V_{HH} is allowed for a maximum cumulative period of 80 hours.

M58LV064A, M58LV064B

Figure 12. Asynchronous Bus Read AC Waveforms

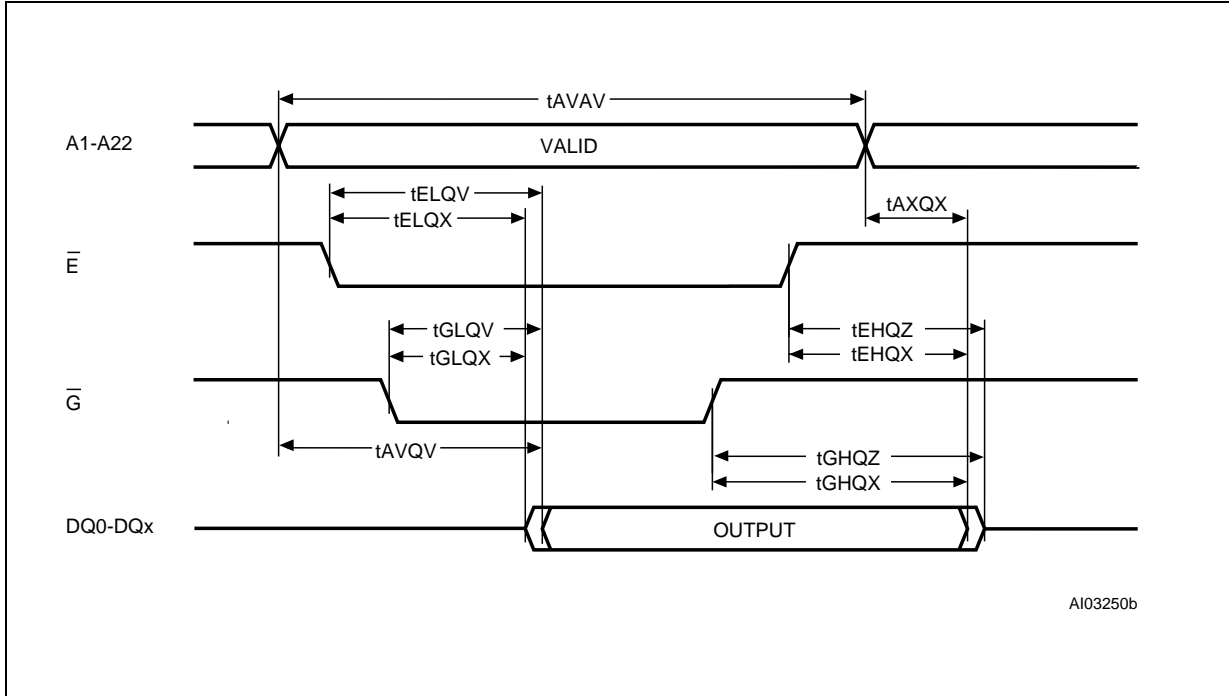

Note: Asynchronous Read (M15 = 1), Random Read (M3 = 0)

Table 17. Asynchronous Bus Read AC Characteristics.

Symbol	Parameter	Test Condition		M58LV064	Unit
				150	
t_{AVAV}	Address Valid to Address Valid	$\bar{E} = V_{IL}, \bar{G} = V_{IL}$	Min	150	ns
t_{AVQV}	Address Valid to Output Valid	$\bar{E} = V_{IL}, \bar{G} = V_{IL}$	Max	150	ns
t_{ELQX}	Chip Enable Low to Output Transition	$\bar{G} = V_{IL}$	Min	0	ns
t_{ELQV}	Chip Enable Low to Output Valid	$\bar{G} = V_{IL}$	Max	150	ns
t_{GLQX}	Output Enable Low to Output Transition	$\bar{E} = V_{IL}$	Min	0	ns
t_{GLQV}	Output Enable Low to Output Valid	$\bar{E} = V_{IL}$	Max	30	ns
t_{EHQX}	Chip Enable High to Output Transition	$\bar{G} = V_{IL}$	Min	0	ns
t_{GHQX}	Output Enable High to Output Transition	$\bar{E} = V_{IL}$	Min	0	ns
t_{AXQX}	Address Transition to Output Transition	$\bar{E} = V_{IL}, \bar{G} = V_{IL}$	Min	0	ns
t_{EHQZ}	Chip Enable High to Output Hi-Z	$\bar{G} = V_{IL}$	Max	10	ns
t_{GHQZ}	Output Enable High to Output Hi-Z	$\bar{E} = V_{IL}$	Max	10	ns

Figure 13. Asynchronous Latch Controlled Bus Read AC Waveforms

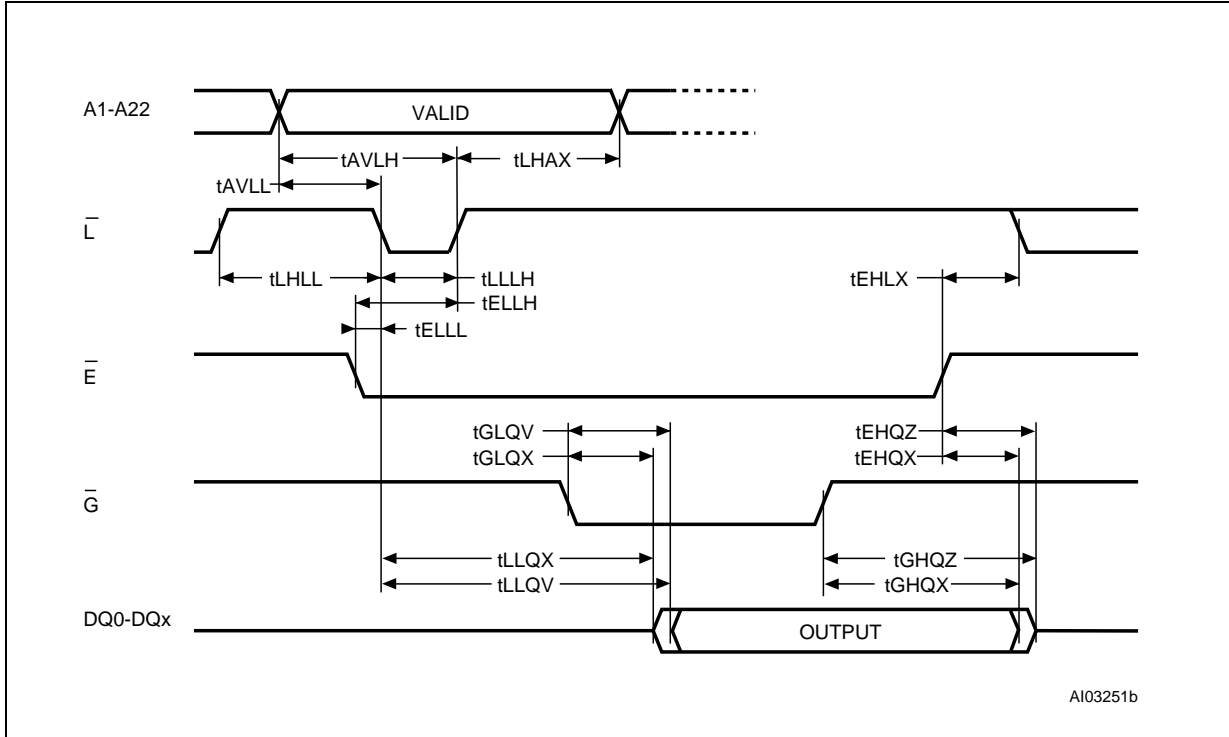

Note: Asynchronous Read (M15 = 1), Latch Enable Controlled (M3 = 1)

Table 18. Asynchronous Latch Controlled Bus Read AC Characteristics

Symbol	Parameter	Test Condition		M58LV064	Unit
				150	
tAVLL	Address Valid to Latch Enable Low	$\bar{E} = V_{IL}$	Min	0	ns
tAVLH	Address Valid to Latch Enable High	$\bar{E} = V_{IL}$	Min	10	ns
tLHLL	Latch Enable High to Latch Enable Low		Min	10	ns
tLLLH	Latch Enable Low to Latch Enable High	$\bar{E} = V_{IL}$	Min	10	ns
tELLL	Chip Enable Low to Latch Enable Low		Min	0	ns
tELLH	Chip Enable Low to Latch Enable High		Min	10	ns
tLLQX	Latch Enable Low to Output Transition	$\bar{E} = V_{IL}, \bar{G} = V_{IL}$	Min	0	ns
tLLQV	Latch Enable Low to Output Valid	$\bar{E} = V_{IL}, \bar{G} = V_{IL}$	Min	150	ns
tLHAX	Latch Enable High to Address Transition	$\bar{E} = V_{IL}$	Min	10	ns
tGLQX	Output Enable Low to Output Transition	$\bar{E} = V_{IL}$	Min	0	ns
tGLQV	Output Enable Low to Output Valid	$\bar{E} = V_{IL}$	Max	20	ns
tEHLX	Chip Enable High to Latch Enable Transition		Min	0	ns

Note: For other timings see Table 17, Asynchronous Bus Read Characteristics.

Figure 14. Asynchronous Page Read AC Waveforms

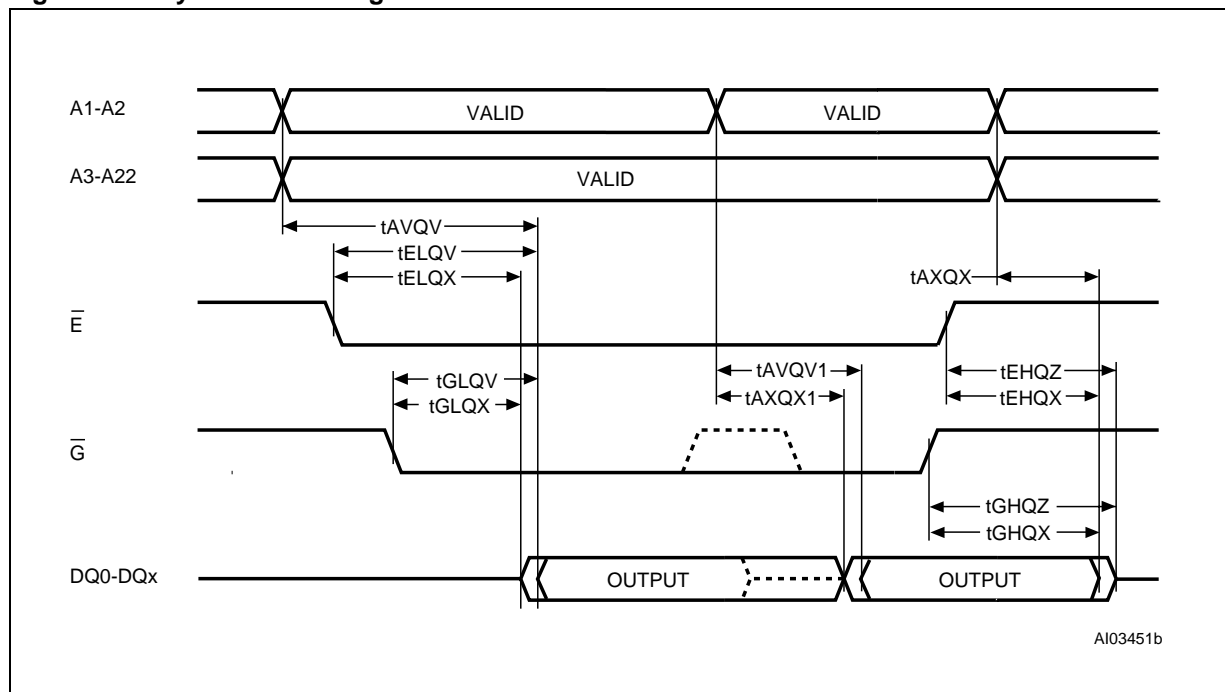

Note: Asynchronous Read (M15 = 1), Random (M3 = 0)

Table 19. Asynchronous Page Read AC Characteristics

Symbol	Parameter	Test Condition		M58LV064	Unit
				150	
tAXQX1	Address Transition to Output Transition	$\bar{E} = V_{IL}, \bar{G} = V_{IL}$	Min	6	ns
tAVQV1	Address Valid to Output Valid	$\bar{E} = V_{IL}, \bar{G} = V_{IL}$	Max	25	ns

Note: For other timings see Table 17, Asynchronous Bus Read Characteristics.

Figure 15. Asynchronous Write AC Waveform, Write Enable Controlled

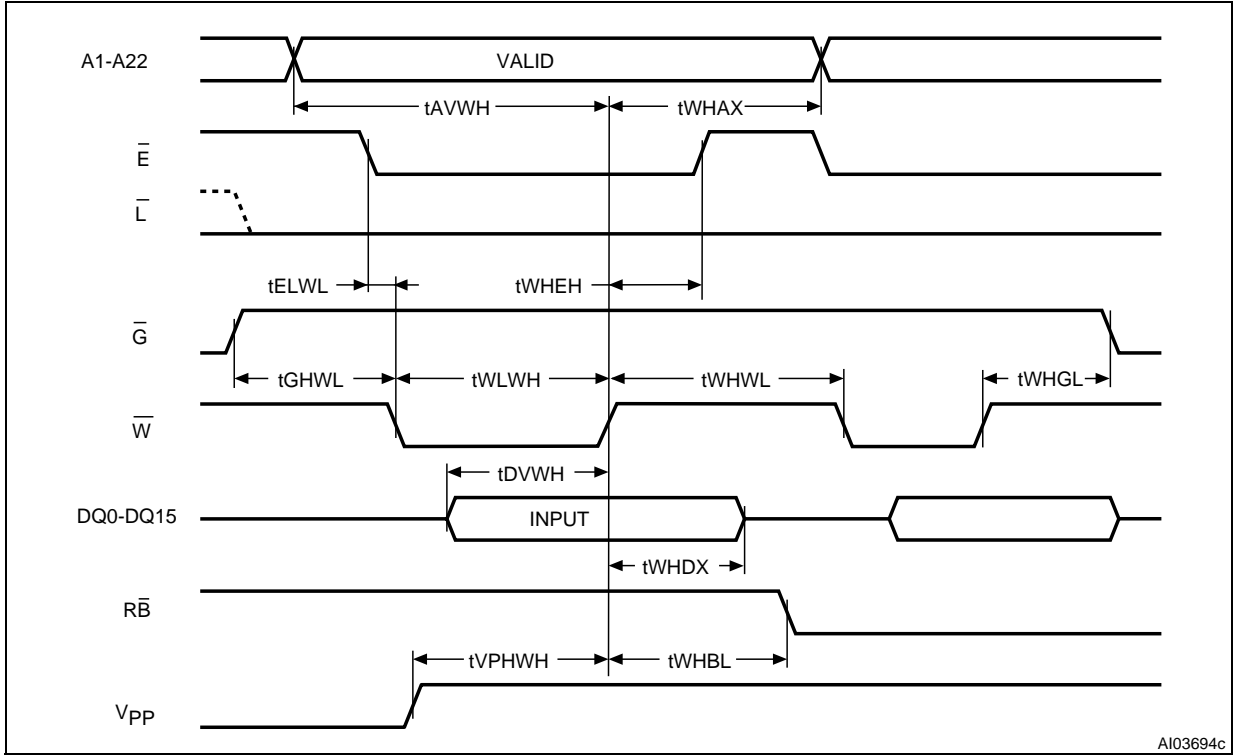

AI03694c

Figure 16. Asynchronous Latch Controlled Write AC Waveform, Write Enable Controlled

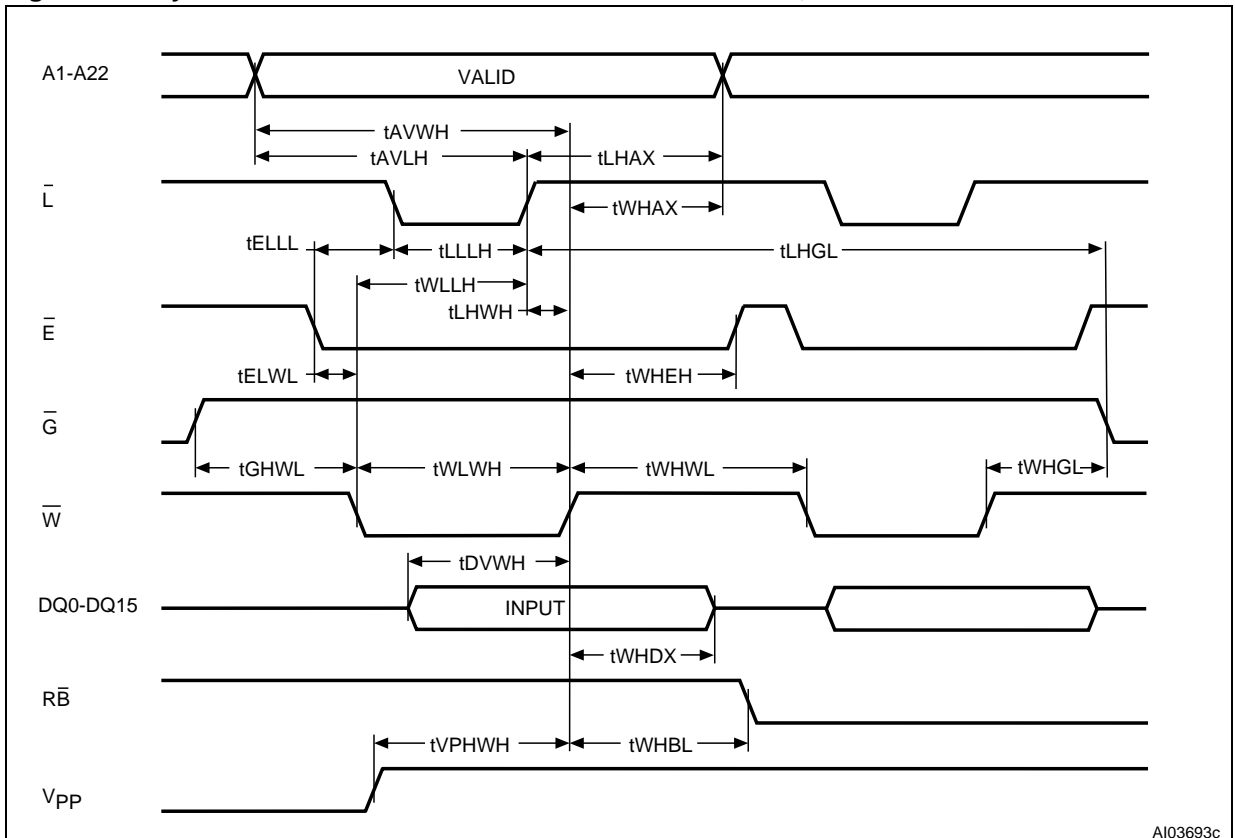

AI03693c

M58LV064A, M58LV064B

Table 20. Asynchronous Write and Latch Controlled Write AC Characteristics, Write Enable Controlled.

Symbol	Parameter	Test Condition		M58LV064	Unit
				150	
t _{AVLH}	Address Valid to Latch Enable High		Min	10	ns
t _{AVWH}	Address Valid to Write Enable High	$\bar{E} = V_{IL}$	Min	50	ns
t _{DVWH}	Data Input Valid to Write Enable High	$\bar{E} = V_{IL}$	Min	50	ns
t _{ELWL}	Chip Enable Low to Write Enable Low		Min	0	ns
t _{ELLL}	Chip Enable Low to Latch Enable Low		Min	0	ns
t _{LHAX}	Latch Enable High to Address Transition		Min	3	ns
t _{LHGL}	Latch Enable High to Output Enable Low		Min	35	ns
t _{LHWH}	Latch Enable High to Write Enable High		Min	0	ns
t _{LLLH}	Latch Enable low to Latch Enable High		Min	10	ns
t _{LLWH}	Latch Enable Low to Write Enable High		Min	50	ns
t _{PHWH}	Program/Erase Enable High to Write Enable High		Min	0	ns
t _{WHAX}	Write Enable High to Address Transition	$\bar{E} = V_{IL}$	Min	10	ns
t _{WHBL}	Write Enable High to Ready/Busy low		Max	90	ns
t _{WHDX}	Write Enable High to Input Transition	$\bar{E} = V_{IL}$	Min	10	ns
t _{WHEH}	Write Enable High to Chip Enable High		Min	0	ns
t _{GHWL}	Output Enable High to Write Enable Low		Min	20	ns
t _{WHGL}	Write Enable High to Output Enable Low		Min	35	ns
t _{WHWL}	Write Enable High to Write Enable Low		Min	30	ns
t _{WLWH}	Write Enable Low to Write Enable High	$\bar{E} = V_{IL}$	Min	70	ns
t _{WLLH}	Write Enable Low to Latch Enable High	$\bar{E} = V_{IL}$	Min	10	ns

Figure 17. Asynchronous Write AC Waveforms, Chip Enable Controlled

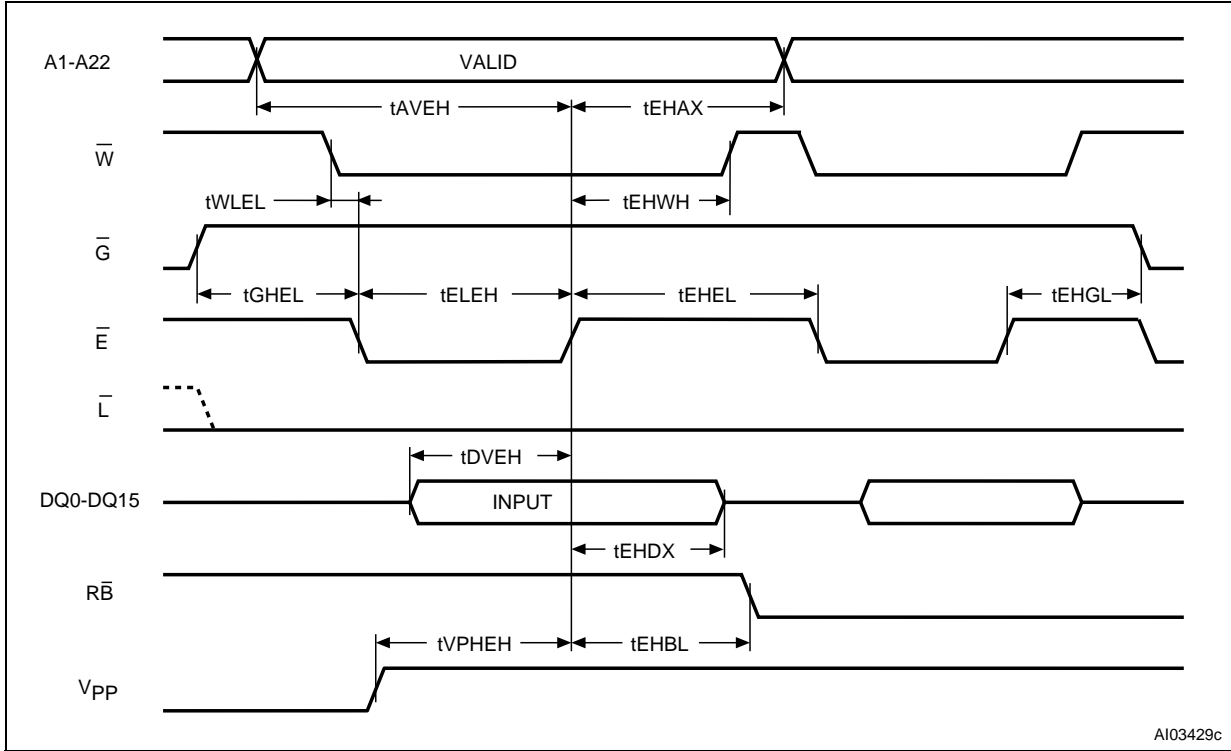

AI03429c

Figure 18. Asynchronous Latch Controlled Write AC Waveforms, Chip Enable Controlled

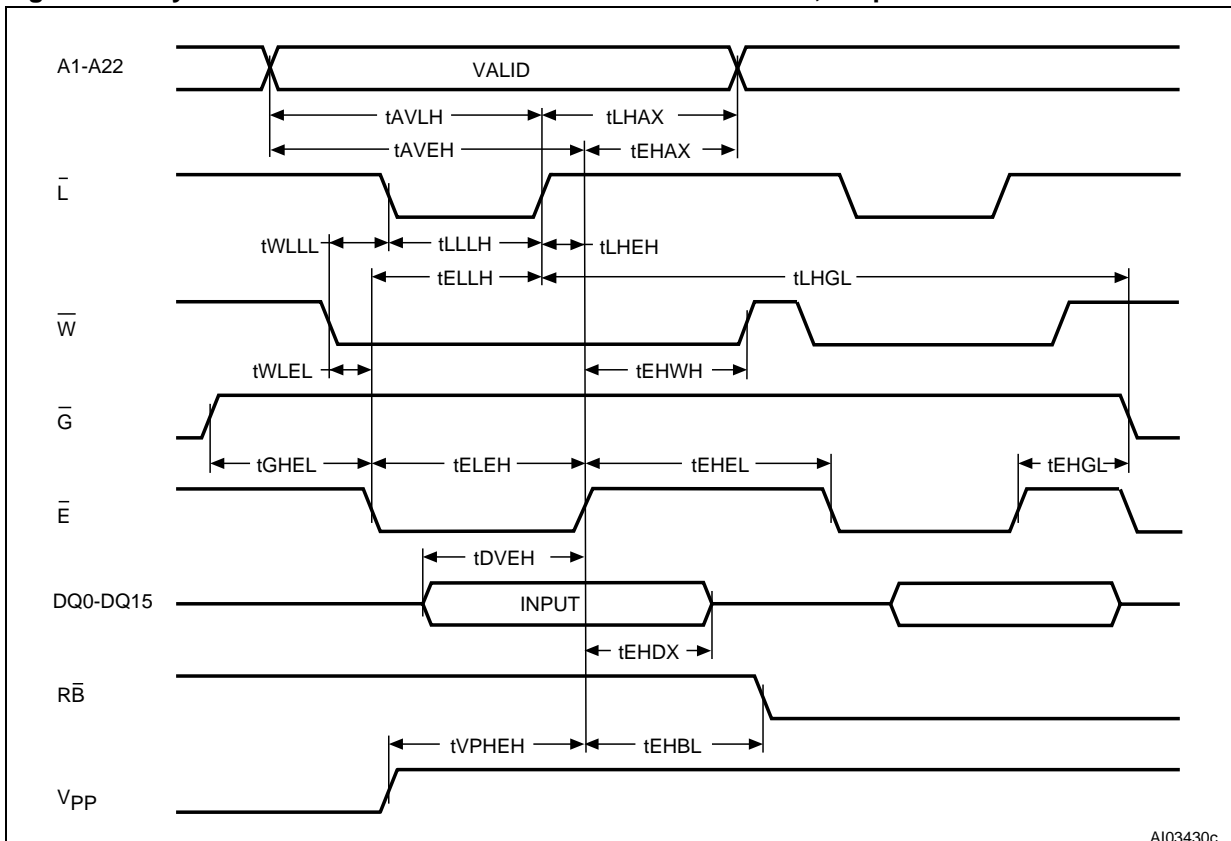

AI03430c

M58LV064A, M58LV064B

Table 21. Asynchronous Write and Latch Controlled Write AC Characteristics, Chip Enable Controlled

Symbol	Parameter	Test Condition		M58LV064	Unit
				150	
t _{AVLH}	Address Valid to Latch Enable High		Min	10	ns
t _{AVEH}	Address Valid to Chip Enable High	$\overline{W} = V_{IL}$	Min	50	ns
t _{DVEH}	Data Input Valid to Chip Enable High	$\overline{W} = V_{IL}$	Min	50	ns
t _{WLEL}	Write Enable Low to Chip Enable Low		Min	0	ns
t _{WLLL}	Write Enable Low to Latch Enable Low		Min	0	ns
t _{LHAX}	Latch Enable High to Address Transition		Min	3	ns
t _{LHGL}	Latch Enable High to Output Enable Low		Min	35	ns
t _{LHEH}	Latch Enable High to Chip Enable High		Min	0	ns
t _{LLLH}	Latch Enable low to Latch Enable High		Min	10	ns
t _{LLEH}	Latch Enable Low to Chip Enable High		Min	50	ns
t _{VPHEH}	Program/Erase Enable High to Chip Enable High		Min	0	ns
t _{EHAX}	Chip Enable High to Address Transition	$\overline{W} = V_{IL}$	Min	10	ns
t _{EHBL}	Chip Enable High to Ready/Busy low		Max	90	ns
t _{EHDX}	Chip Enable High to Input Transition	$\overline{W} = V_{IL}$	Min	10	ns
t _{EHWH}	Chip Enable High to Write Enable High		Min	0	ns
t _{GHEL}	Output Enable High to Chip Enable Low		Min	20	ns
t _{EHGL}	Chip Enable High to Output Enable Low		Min	35	ns
t _{EHCL}	Chip Enable High to Chip Enable Low		Min	30	ns
t _{ELEH}	Chip Enable Low to Chip Enable High	$\overline{W} = V_{IL}$	Min	70	ns
t _{ELLH}	Chip Enable Low to Latch Enable High	$\overline{W} = V_{IL}$	Min	10	ns

Figure 20. Synchronous Burst Read - Continuous - Valid Data Ready Output

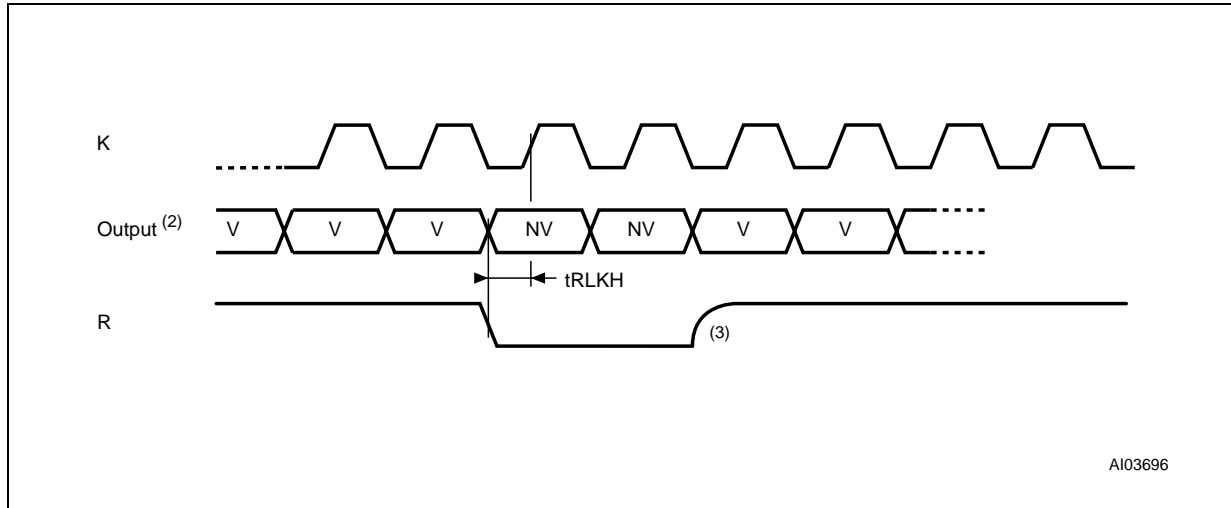

- Note: 1. Valid Data Ready = Valid Low during valid clock edge (M8 = 0)
2. V= Valid output, NV= Not Valid output.
3. R is an open drain output. Depending on the Valid Data Ready pin capacitance load an external pull up resistor must be chosen according to the system clock period.
4. When the system clock frequency is between 33MHz and 50MHz and the Y latency is set to 2, values of \bar{B} sampled on odd clock cycles, starting from the first read are not considered.

Table 22. Synchronous Burst Read AC Characteristics

Symbol	Parameter	Test Condition		M58LV064	Unit
				150	
t _{AVKH}	Address Valid to Active Clock Edge	$\bar{E} = V_{IL}$	Min	10	ns
t _{AVLH}	Address Valid to Latch Enable High	$\bar{E} = V_{IL}$	Min	10	ns
t _{BHKH}	Burst Address Advance High to Active Clock Edge	$\bar{E} = V_{IL}, \bar{G} = V_{IL}, \bar{L} = V_{IH}$	Min	10	ns
t _{BLKH}	Burst Address Advance Low to Active Clock Edge	$\bar{E} = V_{IL}, \bar{G} = V_{IL}, \bar{L} = V_{IH}$	Min	10	ns
t _{ELKH}	Chip Enable Low to Active Clock Edge	$\bar{E} = V_{IL}$	Min	10	ns
t _{ELLH}	Chip Enable Low to Latch Enable High	$\bar{E} = V_{IL}$	Min	10	ns
t _{GLKH}	Output Enable Low to Valid Clock Edge	$\bar{E} = V_{IL}, \bar{L} = V_{IH}$	Min	20	ns
t _{KHAX}	Valid Clock Edge to Address Transition	$\bar{E} = V_{IL}$	Min	10	ns
t _{KHLL}	Valid Clock Edge to Latch Enable Low	$\bar{E} = V_{IL}$	Min	0	ns
t _{KHLH}	Valid Clock Edge to Latch Enable High	$\bar{E} = V_{IL}$	Min	0	ns
t _{KHQX}	Valid Clock Edge to Output Transition	$\bar{E} = V_{IL}, \bar{G} = V_{IL}, \bar{L} = V_{IH}$	Min	3	ns
t _{LLKH}	Latch Enable Low to Valid Clock Edge	$\bar{E} = V_{IL}$	Min	10	ns
t _{LLLH}	Latch Enable Low to Latch Enable High	$\bar{E} = V_{IL}$	Min	10	ns
t _{KHQV}	Valid Clock Edge to Output Valid	$\bar{E} = V_{IL}, \bar{G} = V_{IL}, \bar{L} = V_{IH}$	Max	20	ns
t _{QVKH}	Output Valid to Active Clock Edge	$\bar{E} = V_{IL}, \bar{G} = V_{IL}, \bar{L} = V_{IH}$	Min	5	ns
t _{RLKH}	Valid Data Ready Low to Valid Clock Edge	$\bar{E} = V_{IL}, \bar{G} = V_{IL}, \bar{L} = V_{IH}$	Min	5	ns
t _{KHBL}	Active Clock Edge to Burst Address Advance Low	$\bar{E} = V_{IL}, \bar{G} = V_{IL}, \bar{L} = V_{IH}$	Min	0	ns
t _{KHBH}	Active Clock Edge to Burst Address Advance High	$\bar{E} = V_{IL}, \bar{G} = V_{IL}, \bar{L} = V_{IH}$	Min	0	ns

Note: For other timings see Table 17, Asynchronous Bus Read Characteristics.

Figure 21. Reset, Power-Down and Power-up AC Waveform

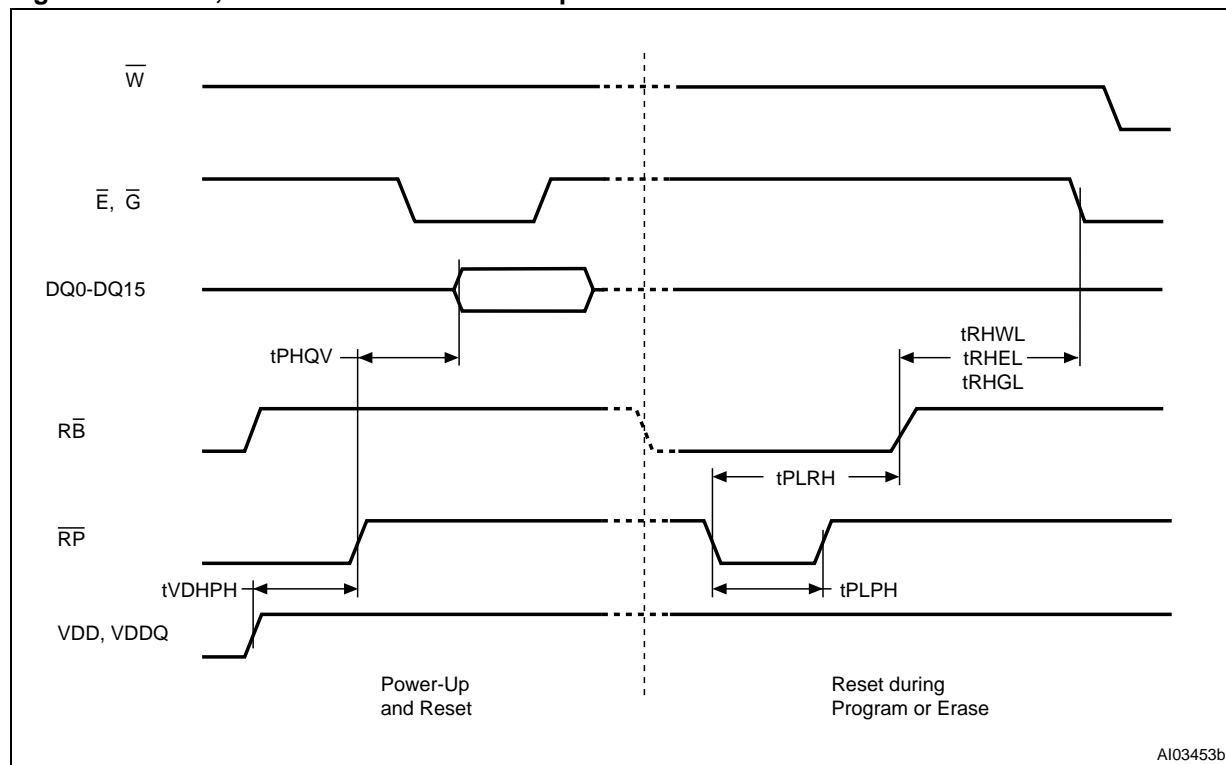

Note: Write Enable (\overline{W}) and Output Enable (\overline{G}) cannot be low together.

Table 23. Reset, Power-Down and Power-up AC Characteristics

Symbol	Parameter		M58LV064	Unit
			150	
t _{PHQV}	Reset/Power-Down High to Data Valid	Min	10	μs
t _{RHWL} t _{RHEL} t _{RHGL}	Ready/Busy High to Write Enable Low, Chip Enable Low, Output Enable Low (Program/Erase Controller Active)	Min	10	μs
t _{PLPH}	Reset/Power-Down Low to Reset/Power-Down High	Min	100	ns
t _{PLRH}	Reset/Power-Down Low to Ready High	Max	30	μs
t _{VDHPH}	Supply Voltages High to Reset/Power-Down High	Min	1	μs

PACKAGE MECHANICAL

Figure 22. TSOP56 - 56 lead Plastic Thin Small Outline, 14 x 20 mm, Package Outline

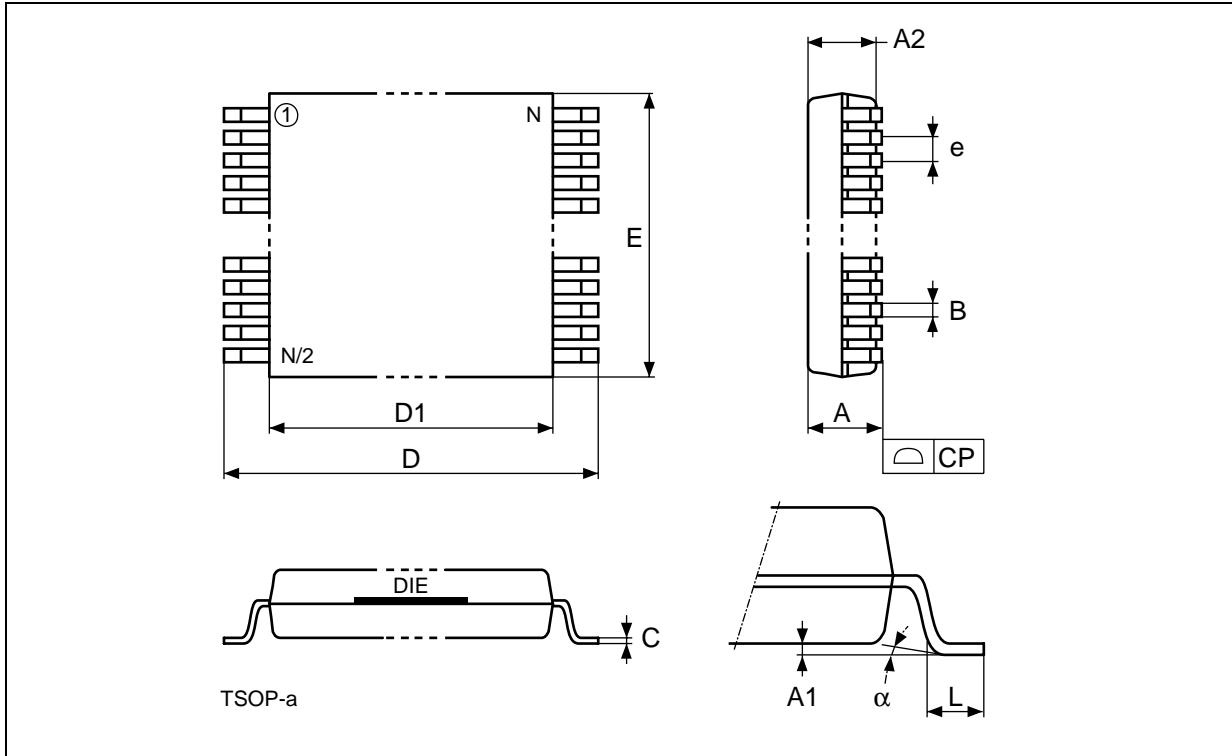

Note: Drawing is not to scale.

Table 24. TSOP56 - 56 lead Plastic Thin Small Outline, 14 x 20 mm, Package Mechanical Data

Symbol	mm			inches		
	Typ	Min	Max	Typ	Min	Max
A			1.20			0.0472
A1		0.05	0.15		0.0020	0.0059
A2		0.95	1.05		0.0374	0.0413
B		0.17	0.27		0.0067	0.0106
C		0.10	0.21		0.0039	0.0083
D		19.80	20.20		0.7795	0.7953
D1		18.30	18.50		0.7205	0.7283
E		13.90	14.10		0.5472	0.5551
e	0.50	-	-	0.0197	-	-
L		0.50	0.70		0.0197	0.0276
alpha		0°	5°		0°	5°
N		56			56	
CP			0.10			0.0039

M58LV064A, M58LV064B

Figure 23. TBGA64 - 10x13mm, 8 x 8 ball array 1mm pitch, Package Outline

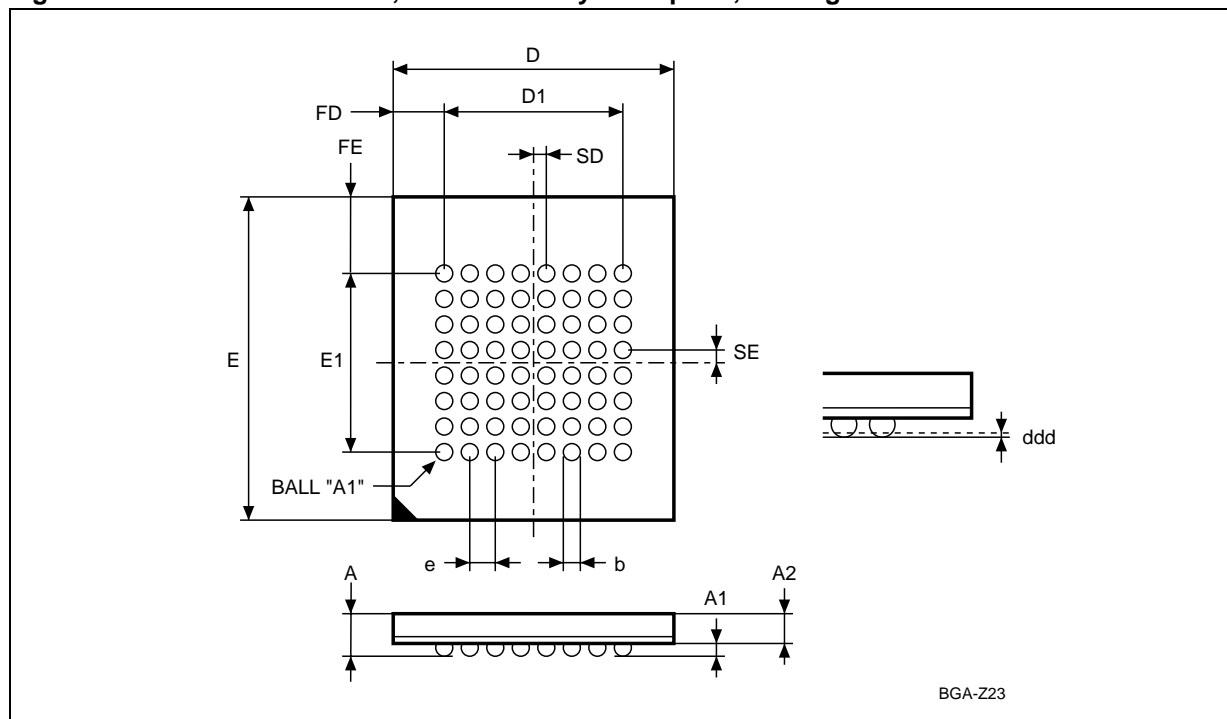

Note: Drawing is not to scale.

Table 25. TBGA64 - 10x13mm, 8 x 8 ball array, 1 mm pitch, Package Mechanical Data

Symbol	millimeters			inches		
	Typ	Min	Max	Typ	Min	Max
A			1.200			0.0472
A1	0.300	0.200	0.350	0.0118	0.0079	0.0138
A2			0.850			0.0335
b		0.400	0.500		0.0157	0.0197
D	10.000	9.900	10.100	0.3937	0.3898	0.3976
D1	7.000	–	–	0.2756	–	–
ddd			0.100			0.0039
e	1.000	–	–	0.0394	–	–
E	13.000	12.900	13.100	0.5118	0.5079	0.5157
E1	7.000	–	–	0.2756	–	–
FE	1.500	–	–	0.0591	–	–
FD	3.000	–	–	0.1181	–	–
SD	0.500	–	–	0.0197	–	–
SE	0.500	–	–	0.0197	–	–

Figure 24. TBGA80 - 10x13mm, 8 x 10 ball array, 1mm pitch, Package Outline

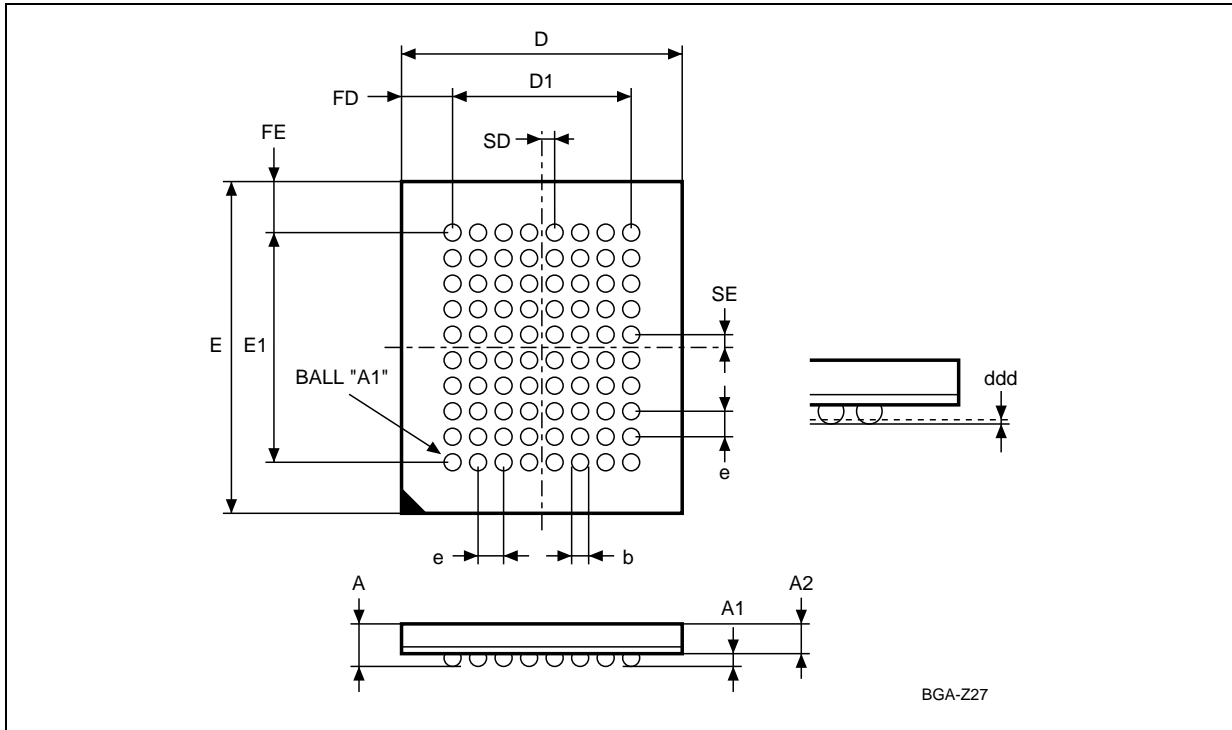

Note: Drawing is not to scale.

Table 26. TBGA80 - 10x13mm, 8 x 10 ball array, 1mm pitch, Package Mechanical Data

Symbol	millimeters			inches		
	Typ	Min	Max	Typ	Min	Max
A			1.200			0.0472
A1	0.300	0.200	0.350	0.0118	0.0079	0.0138
A2			0.850			0.0335
b		0.400	0.500		0.0157	0.0197
D	10.000	9.900	10.100	0.3937	0.3898	0.3976
D1	7.000	–	–	0.2756	–	–
ddd			0.100			0.0039
E	13.000	12.900	13.100	0.5118	0.5079	0.5157
E1	9.000	–	–	0.3543	–	–
e	1.000	–	–	0.0394	–	–
FD	1.500	–	–	0.0591	–	–
FE	2.000	–	–	0.0787	–	–
SD	0.500	–	–	0.0197	–	–
SE	0.500	–	–	0.0197	–	–

M58LV064A, M58LV064B

PART NUMBERING

Table 27. Ordering Information Scheme

Example:	M58LV064A	150	N	1	T
Device Type M58	 				
Architecture L = Multi-Bit Cell, Burst Mode, Page Mode					
Operating Voltage $V = V_{DD} = 3.0V$ to $3.6V$; $V_{DDQ} = 1.8$ to V_{DD}					
Device Function 064A = 64 Mbit (x16), Uniform Block 064B = 64 Mbit (x16/x32), Uniform Block					
Speed 150 = 150 ns					
Package N = TSOP56: 14 x 20 mm (M58LV064A) ZA = TBGA64: 10 x 13mm, 1mm pitch (M58LV064A) ZA = TBGA80: 10 x 13mm, 1mm pitch (M58LV064B)					
Temperature Range 1 = 0 to 70 °C 6 = -40 to 85 °C					
Option T = Tape & Reel Packing					

Note: Devices are shipped from the factory with the memory content bits erased to '1'.

For a list of available options (Speed, Package, etc.) or for further information on any aspect of this device, please contact the ST Sales Office nearest to you.

APPENDIX A. BLOCK ADDRESS TABLE

Table 28. Block Addresses

Block Number	Address Range (x16 Bus Width)	Address Range (x32 Bus Width)
64	3F0000h-3FFFFFFh	1F8000h-1FFFFFFh
63	3E0000h-3FFFFFFh	1F0000h-1F7FFFh
62	3D0000h-3DFFFFFFh	1E8000h-1EFFFFh
61	3C0000h-3CFFFFFFh	1E0000h-1E7FFFh
60	3B0000h-3BFFFFFFh	1D8000h-1DFFFFh
59	3A0000h-3AFFFFFFh	1D0000h-1D7FFFh
58	390000h-39FFFFFFh	1C8000h-1CFFFFh
57	380000h-38FFFFFFh	1C0000h-1C7FFFh
56	370000h-37FFFFFFh	1B8000h-1BFFFFh
55	360000h-36FFFFFFh	1B0000h-1B7FFFh
54	350000h-35FFFFFFh	1A8000h-1AFFFFh
53	340000h-34FFFFFFh	1A0000h-1A7FFFh
52	330000h-33FFFFFFh	198000h-19FFFFh
51	320000h-32FFFFFFh	190000h-197FFFh
50	310000h-31FFFFFFh	188000h-18FFFFh
49	300000h-30FFFFFFh	180000h-187FFFh
48	2F0000h-2FFFFFFh	178000h-17FFFFh
47	2E0000h-2EFFFFFFh	170000h-177FFFh
46	2D0000h-2DFFFFFFh	168000h-16FFFFh
45	2C0000h-2CFFFFFFh	160000h-167FFFh
44	2B0000h-2BFFFFFFh	158000h-15FFFFh
43	2A0000h-2AFFFFFFh	150000h-157FFFh
42	290000h-29FFFFFFh	148000h-14FFFFh
41	280000h-28FFFFFFh	140000h-147FFFh
40	270000h-27FFFFFFh	138000h-13FFFFh
39	260000h-26FFFFFFh	130000h-137FFFh
38	250000h-25FFFFFFh	128000h-12FFFFh
37	240000h-24FFFFFFh	120000h-127FFFh
36	230000h-23FFFFFFh	118000h-11FFFFh
35	220000h-22FFFFFFh	110000h-117FFFh
34	210000h-21FFFFFFh	108000h-10FFFFh
33	200000h-20FFFFFFh	100000h-107FFFh

Block Number	Address Range (x16 Bus Width)	Address Range (x32 Bus Width)
32	1F0000h-1FFFFFFh	0F8000h-0FFFFFFh
31	1E0000h-1EFFFFh	0F0000h-0F7FFFh
30	1D0000h-1DFFFFh	0E8000h-0EFFFFh
29	1C0000h-1CFFFFh	0E0000h-0E7FFFh
28	1B0000h-1BFFFFh	0D8000h-0DFFFFh
27	1A0000h-1AFFFFh	0D0000h-0D7FFFh
26	190000h-19FFFFh	0C8000h-0CFFFFh
25	180000h-18FFFFh	0C0000h-0C7FFFh
24	170000h-17FFFFh	0B8000h-0BFFFFh
23	160000h-16FFFFh	0B0000h-0B7FFFh
22	150000h-15FFFFh	0A8000h-0AFFFFh
21	140000h-14FFFFh	0A0000h-0A7FFFh
20	130000h-13FFFFh	098000h-09FFFFh
19	120000h-12FFFFh	090000h-097FFFh
18	110000h-11FFFFh	088000h-08FFFFh
17	100000h-10FFFFh	080000h-087FFFh
16	0F0000h-0FFFFFFh	078000h-07FFFFh
15	0E0000h-0EFFFFh	070000h-077FFFh
14	0D0000h-0DFFFFh	068000h-06FFFFh
13	0C0000h-0CFFFFh	060000h-067FFFh
12	0B0000h-0BFFFFh	058000h-05FFFFh
11	0A0000h-0AFFFFh	050000h-057FFFh
10	090000h-09FFFFh	048000h-04FFFFh
9	080000h-08FFFFh	040000h-047FFFh
8	070000h-07FFFFh	038000h-03FFFFh
7	060000h-06FFFFh	030000h-037FFFh
6	050000h-05FFFFh	028000h-02FFFFh
5	040000h-04FFFFh	020000h-027FFFh
4	030000h-03FFFFh	018000h-01FFFFh
3	020000h-02FFFFh	010000h-017FFFh
2	010000h-01FFFFh	008000h-00FFFFh
1	000000h-00FFFFh	000000h-007FFFh

APPENDIX B. COMMON FLASH INTERFACE - CFI

The Common Flash Interface is a JEDEC approved, standardized data structure that can be read from the Flash memory device. It allows a system software to query the device to determine various electrical and timing parameters, density information and functions supported by the memory. The system can interface easily with the device, enabling the software to upgrade itself when necessary.

When the CFI Query Command (RCFI) is issued the device enters CFI Query mode and the data structure is read from the memory. Tables 29, 30,

31, 32, 33 and 34 show the addresses used to retrieve the data.

When the M58LV064B is used in x16 mode, A1 is the Least Significant Address. Toggling A1 will not change the CFI information available on the DQ15-DQ0 outputs.

To read the CFI, in the M58LV064A and M58LV064B devices, in x16 mode, addresses A23-A1 are used; for the x32 mode of the M58LV064B device only addresses A23-A2 are used. To read the CFI, in the M58LV064B device, in x16 mode, the address offsets shown must be multiplied by two in hexadecimal.

Table 29. Query Structure Overview

Offset	Sub-section Name	Description
00h		Manufacturer Code
01h		Device Code
10h	CFI Query Identification String	Command set ID and algorithm data offset
1Bh	System Interface Information	Device timing and voltage information
27h	Device Geometry Definition	Flash memory layout
P(h) ⁽¹⁾	Primary Algorithm-specific Extended Query Table	Additional information specific to the Primary Algorithm (optional)
A(h) ⁽²⁾	Alternate Algorithm-specific Extended Query Table	Additional information specific to the Alternate Algorithm (optional)
(SBA+02)h	Block Status Register	Block-related Information

Note: 1. Offset 15h defines P which points to the Primary Algorithm Extended Query Address Table.
 2. Offset 19h defines A which points to the Alternate Algorithm Extended Query Address Table.
 3. SBA is the Start Base Address for each block.

Table 30. CFI - Query Address and Data Output

Address ⁽⁴⁾ A22-A1 (M58LV064A) A22-A2 (M58LV064B)	Data		Instruction
	DQ31-DQ16 ⁽⁶⁾	DQ15-DQ0	
10h	0000	0051h	Query ASCII String 0051h; "Q" 0052h; "R" 0059h; "Y"
11h	0000	0052h	
12h	0000	0059h	
13h	0000	0001h	Primary Vendor: Command Set and Control Interface ID Code
14h	0000	0000h	
15h	0000	0031h	Primary algorithm extended Query Address Table: P(h)
16h	0000	0000h	
17h	0000	0000h	Alternate Vendor: Command Set and Control Interface ID Code
18h	0000	0000h	
19h	0000	0000h	Alternate Algorithm Extended Query address Table
1Ah ⁽⁵⁾	0000	0000h	

- Note:
1. The x8 or Byte Address mode is not available.
 2. With the x16 Bus Width, the value of the address location of the CFI Query is independent of A1 pad (M58LV064B).
 3. Query Data are always presented on DQ7-DQ0. DQ31-DQ8 are set to '0'.
 4. For M58LV064B, A1 = Don't Care.
 5. Offset 19h defines A which points to the Alternate Algorithm Extended Query Address Table.
 6. DQ31-DQ16 are available in the M58LV064B only. They are in the high-impedance state when the device operates in x16 mode.

M58LV064A, M58LV064B

Table 31. CFI - Device Voltage and Timing Specification

Address ⁽⁴⁾ A22-A1 (M58LV064A) A22-A2 (M58LV064B)	DQ31-DQ16 ⁽⁵⁾	DQ15-DQ0	Description
1Bh	0000h	0030h ⁽¹⁾	V _{DD} Min, 3.0V M58LV064
1Ch	0000h	0036h ⁽¹⁾	V _{DD} max, 3.6V
1Dh	0000h	0000h ⁽²⁾	V _{PP} min – Not Available
1Eh	0000h	0000h ⁽²⁾	V _{PP} max – Not Available
1Fh	0000h	0007h	2 ⁿ μs typical time-out for Word Program, DWord Program – Not Available
20h	0000h	0007h	2 ⁿ μs typical time-out for max buffer write
21h	0000h	000Ah	2 ⁿ ms, typical time-out for Erase Block
22h	0000h	0000h ⁽³⁾	2 ⁿ ms, typical time-out for chip erase – Not Available
23h	0000h	0004h	2 ⁿ x typical for Word Program time-out max – (Dword Not Available)
24h	0000h	0004h	2 ⁿ x typical for buffer write time-out max
25h	0000h	0004h	2 ⁿ x typical for individual block erase time-out maximum
26h	0000h	0000h ⁽³⁾	2 ⁿ x typical for chip erase max time-out – Not Available

Note: 1. Bits are coded in Binary Code Decimal, bit7 to bit4 are scaled in Volts and bit3 to bit0 in mV.

2. Bit7 to bit4 are coded in Hexadecimal and scaled in Volts while bit3 to bit0 are in Binary Code Decimal and scaled in 100mV.

3. Not supported.

4. For M58LV064B, A1 = Don't Care.

5. DQ31-DQ16 are available in the M58LV064B only. They are in the high-impedance state when the device operates in x16 mode.

Table 32. Device Geometry Definition

Address ⁽¹⁾ A22-A1 (M58LV064A) A22-A2 (M58LV064B)	DQ31-DQ16 ⁽²⁾	DQ15-DQ0	Description
27h	0000h	0017h	2 ⁿ number of bytes memory Size
28h	N/A	0001h	Device Interface M58LV064A
	0000h	0004h	Device Interface M58LV064B
29h	0000h	0000h	Maximum number of bytes in Write Buffer, 2 ⁿ
2Ah	0000h	0005h	
2Bh	0000h	0000h	
2Ch	0000h	0001h	Bit7-0 = number of Erase Block Regions in device
2Dh	0000h	003Fh	Number (n-1) of Erase Blocks of identical size; n=64
2Eh	0000h	0000h	
2Fh	0000h	0000h	Erase Block Region Information x 256 bytes per Erase block (128K bytes)
30h	0000h	0002h	

Note: 1. For M58LV064B, A1 = Don't Care. N/A = Not Applicable

2. DQ31-DQ16 are available in the M58LV064B only. They are in the high-impedance state when the device operates in x16 mode.

Table 33. Block Status Register

Address A22-A1 (M58LV064A) A22-A2 (M58LV064B)	Data		Selected Block Information
(BA+2)h ⁽¹⁾	bit0	0	Block Unprotected
		1	Block Protected
	bit7-1	0	Reserved for future features

Note: 1. BA specifies the block address location, A22-A17.

M58LV064A, M58LV064B

Table 34. Extended Query information

Address offset	Address A22-A1 (M58LV064A) A22-A2 (M58LV064B)	DQ31-DQ16 ⁽¹⁾	DQ15-DQ0	Description
(P)h	31h	0000h	0050h	Query ASCII string - Extended Table 0050h; "P" 0052h; "R" 0059h; "Y"
(P+1)h	32h	0000h	0052h	
(P+2)h	33h	0000h	0049h	
(P+3)h	34h	0000h	0031h	Major version number
(P+4)h	35h	0000h	0031h	Minor version number
(P+5)h	36h	0000h	008Eh	Optional Feature: (1=yes, 0=no) bit0, Chip Erase Supported (0=no) bit1, Suspend Erase Supported (1=yes) bit2, Suspend Program Supported (1=yes) bit3, Protect/Unprotect Supported (1=yes) bit4, Queue Erase Supported (0=no) bit5, Instant individual block locking Supported (0=no) bit6, Protection Bits Supported (0=no) bit7, Page Read Supported (1=yes) bit8, Synchronous Read Supported (1=yes) Bit 31-9 reserved for future use
(P+6)h	37h	0000h	0001h	
(P+7)h	38h	0000h	0000h	
(P+8)h	39h	0000h	0000h	
(P+9)h	3Ah	0000h	0001h	Supported functions after Suspend: Program allowed after Erase Suspend (1=yes) (refer to Commands for other allowed functions) Bit 7-1 reserved for future use
(P+A)h	3Bh	0000h	0001h	Block Status Register bit 0 Block Protect Bit Status active (1=yes) bits 1-15 are reserved
(P+B)h				
(P+C)h	3Ch	0000h	0033h	V _{DD} OPTIMUM Program/Erase voltage conditions
(P+D)h	3Dh	0000h	0033h	V _{PP} OPTIMUM Program/Erase voltage conditions
(P+E)h	3Eh	0000h	00FFh	Not available
(P+F)h	3Fh	0000h	00FFh	Not available
(P+10)h	40h	0000h	00FFh	Not available
(P+11)h	41h	0000h	00FFh	Not available
(P+12)h	42h	0000h	00FFh	Not available
(P+13)h	43h	0000h	0003h	Page Read: 2 ⁿ Bytes (n = bits 0-7)
(P+14)h	44h	0000h	0004h	Synchronous mode configuration fields
(P+15)h	45h	0000h	0000h	n where 2 ⁿ⁺¹ is the number of Words/Double-Words for the burst Length (= 2)
(P+16)h	46h	0000h	0001h	n where 2 ⁿ⁺¹ is the number of Words/Double-Words for the burst Length (= 4)
(P+17)h	47h	0000h	0002h	n where 2 ⁿ⁺¹ is the number of Words/Double-Words for the burst Length (= 8) (x16 mode only)
(P+18)h	48h	0000h	0007h	Burst Continuous

Note: 1. DQ31-DQ16 are available in the M58LV064B only. They are in the high-impedance state when the device operates in x16 mode.

APPENDIX C. FLOW CHARTS

Figure 25. Write to Buffer and Program Flowchart and Pseudo Code

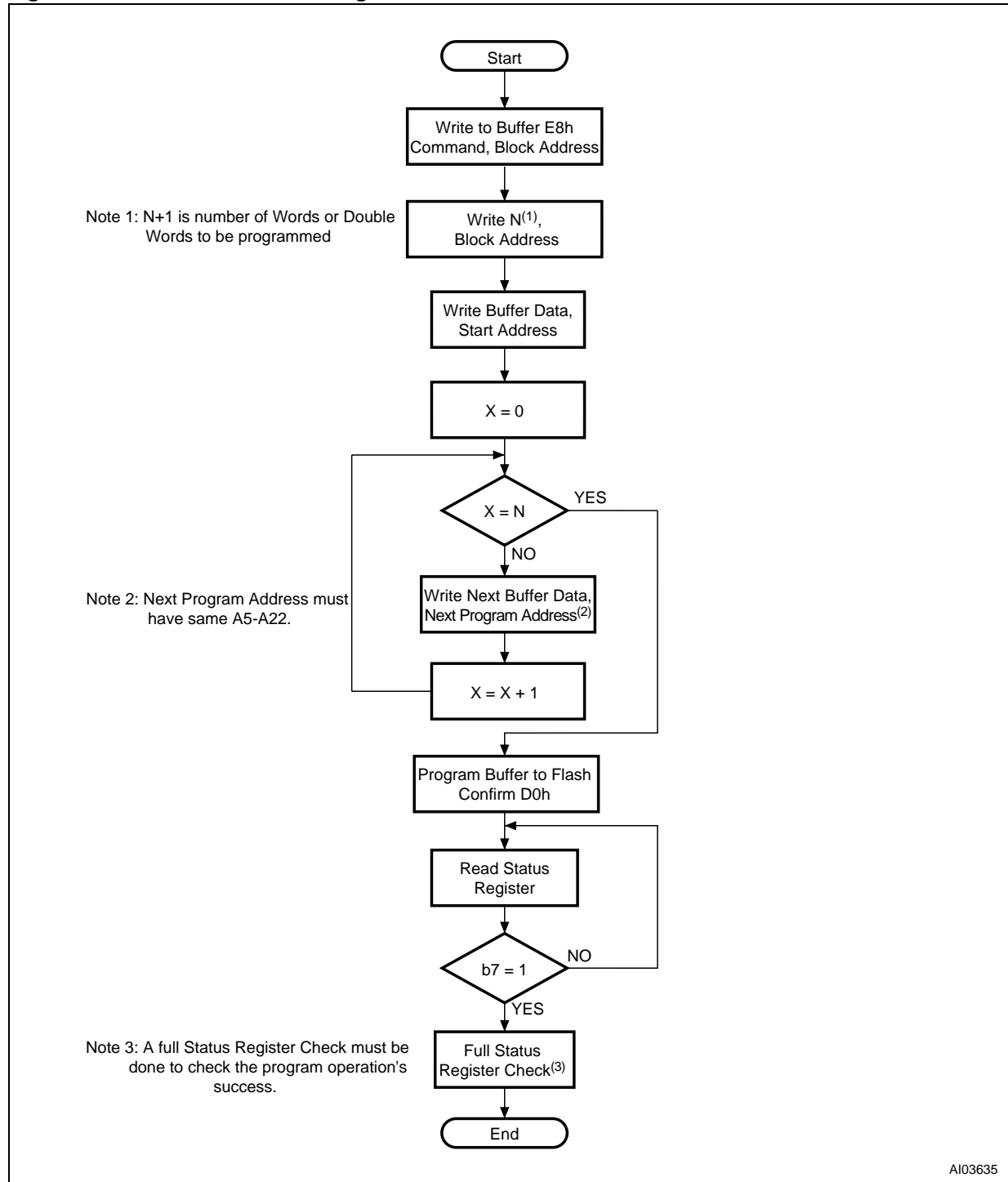

Figure 26. Program Suspend & Resume Flowchart and Pseudo Code

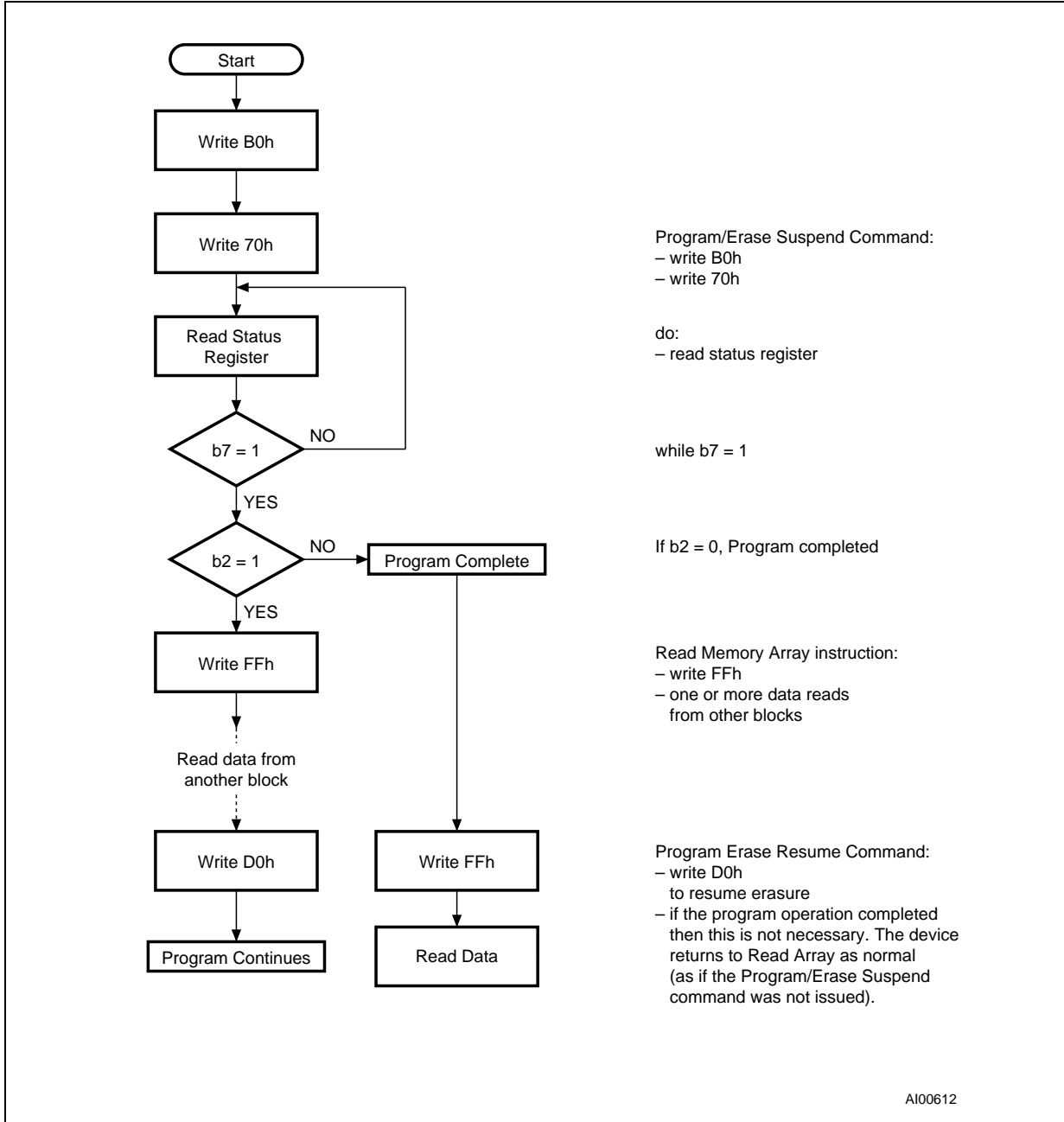
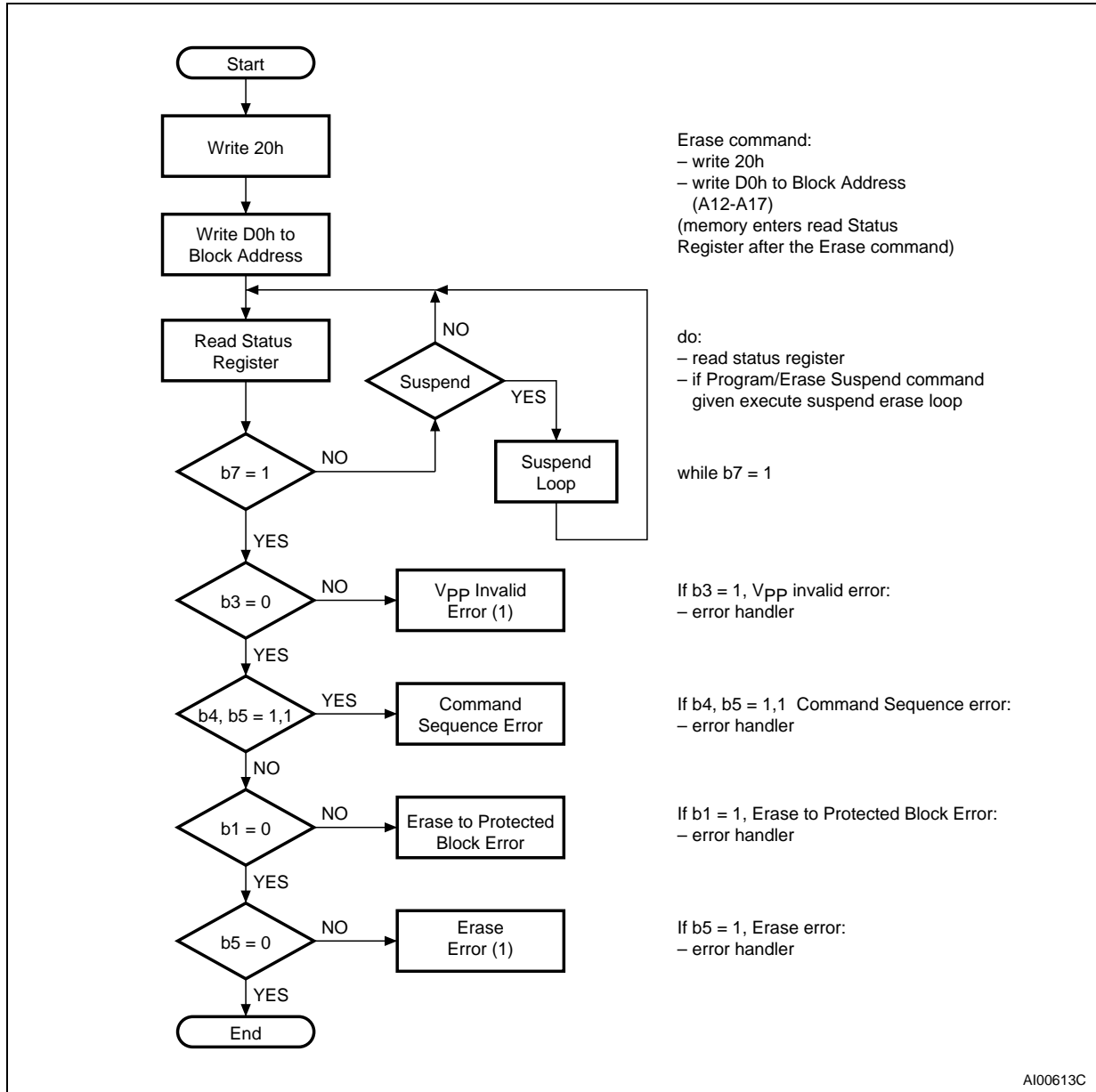

Figure 27. Erase Flowchart and Pseudo Code



Note: 1. If an error is found, the Status Register must be cleared (Clear Status Register Command) before further Program or Erase operations.

Figure 28. Erase Suspend & Resume Flowchart and Pseudo Code

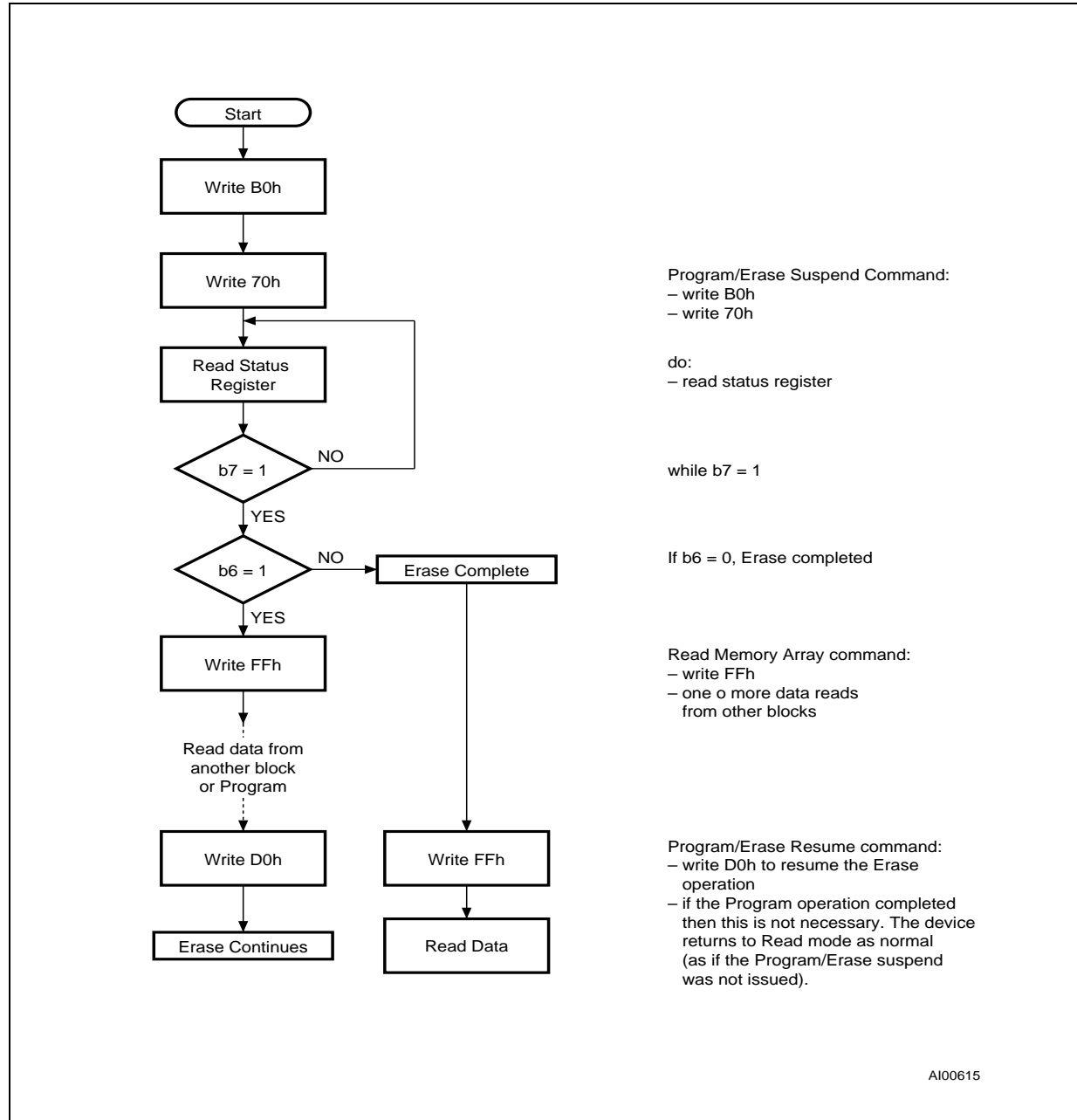

Figure 29. Command Interface and Program Erase Controller Flowchart (a)

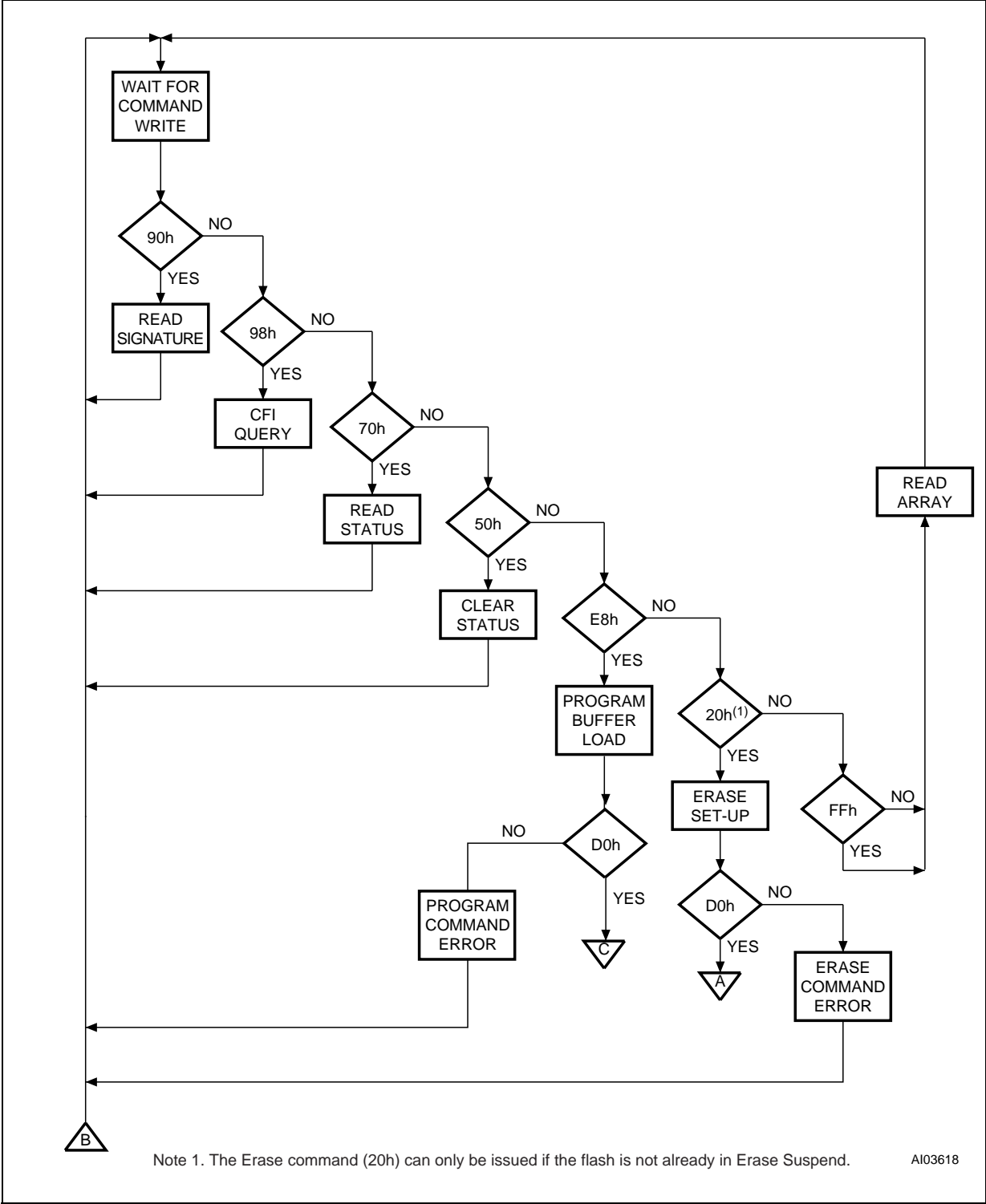
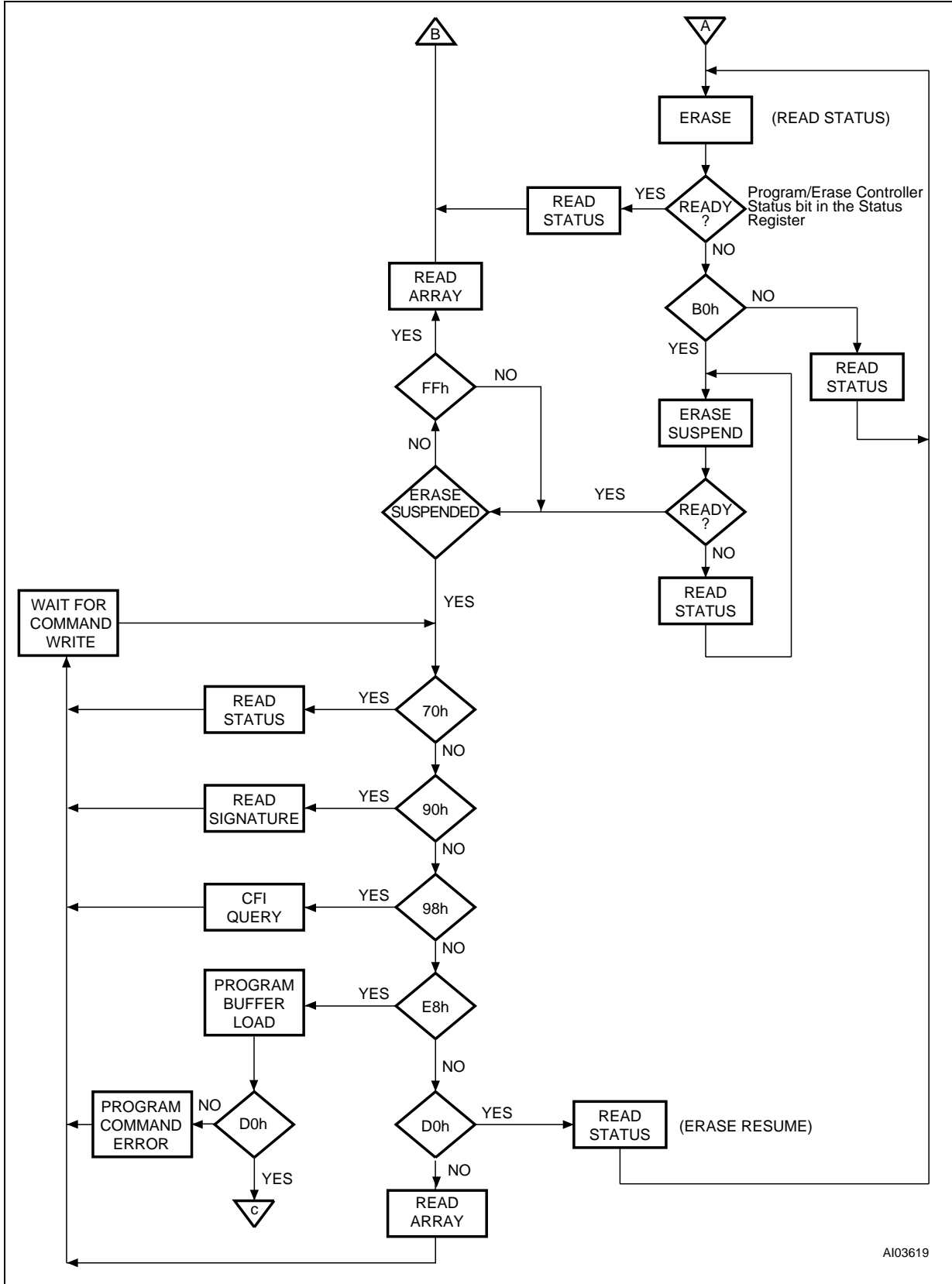
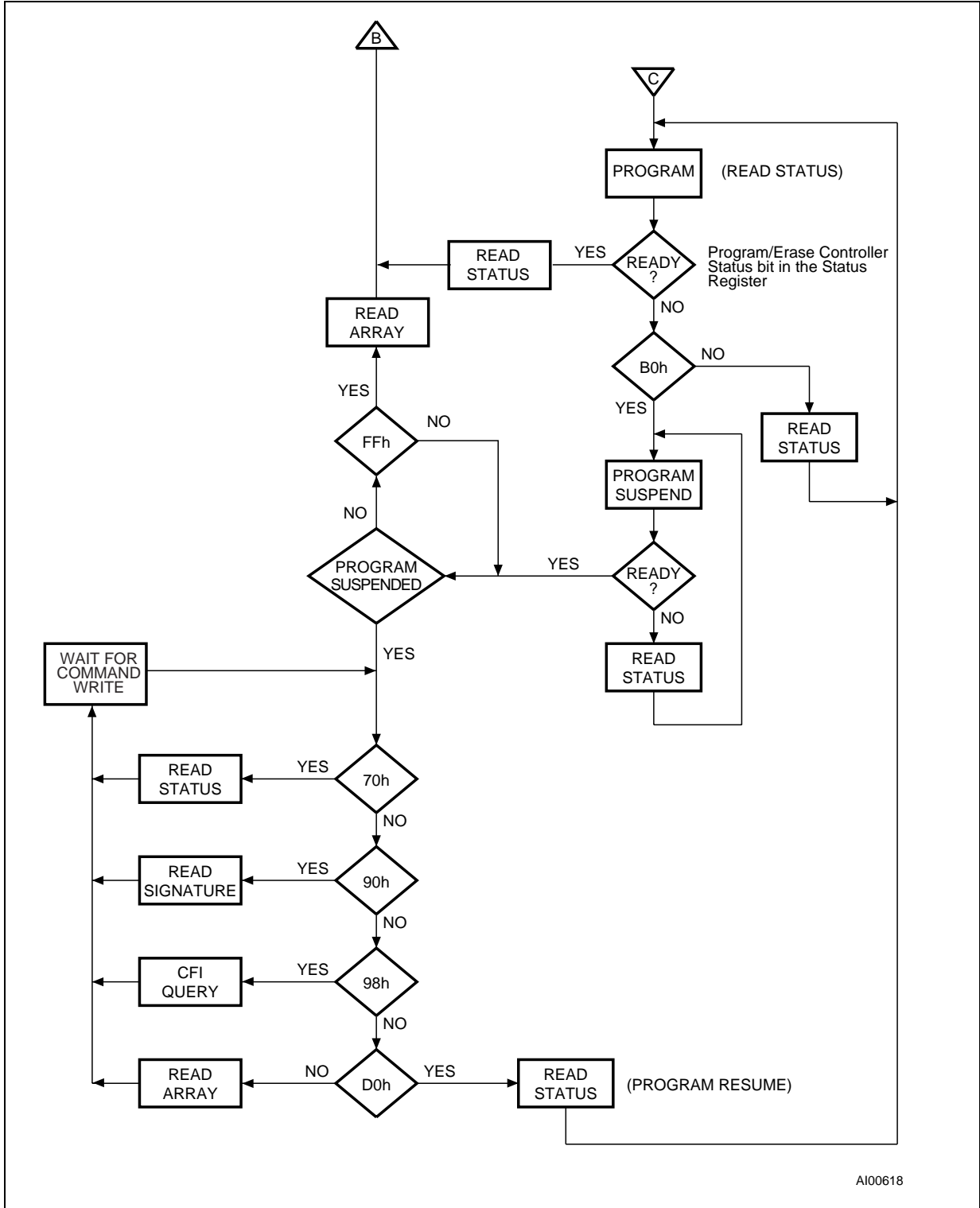

Figure 30. Command Interface and Program Erase Controller Flowchart (b)



A103619

Figure 31. Command Interface and Program Erase Controller Flowchart (c)



AI00618

M58LV064A, M58LV064B

REVISION HISTORY

Table 35. Document Revision History

Date	Version	Revision Details
September 1999	-01	First Issue.
June 2000	-02	Corrections.
02-Mar-01	-03	Major rewrite and restructure.
26-Mar-01	-04	Corrections in CFI tables, TBGA80 and TBGA64 Package Mechanical Dimensions updated.
06-Apr-01	-05	Correction in Asynchronous Bus Write.
15-May-01	-06	120ns speed class added, corrections Figures 7 , 8 and 9.
05-Jun-01	-07	Corrections to Figures 15,16,17 and 18.
10-Dec-2001	-08	M58LV064 part number added for 3.0 to 3.6 voltage range, 120ns speed class removed, corrections to: Program/Erase Enable Signal description, Read and Clear Status Register Commands, Set Burst Configuration Register Command and Burst Configuration Register Tables, Table 10, Read Electronic Signature, descriptions of Status Register Bits 7, 5, 4, 3 and 1, Table 12 Status Register Bits, Asynchronous Read AC Characteristics timing t_{GLQV} , CFI Tables and Flowchart Figures 25 and 27. Corrections to Figures 15, 16, 17, 18 and 21, and Tables 20, 21 and 23.
08-Jul-2002	-09	Part numbers M58LW064A and M58LW064B removed from datasheet, parameter t_{PHQV} changed in Table 23.
16-Dec-2002	9.1	Version number format modified (major.minor). REVISION HISTORY moved to end of document. M58LV064A and M58LV064B device codes changed. Table 10, Read Electronic Signature, clarified. Data Retention information added to Table 11, Program, Erase Times and Program Erase Endurance Cycles. CFI information (Tables 30, 31, 32 and 34) clarified.

Information furnished is believed to be accurate and reliable. However, STMicroelectronics assumes no responsibility for the consequences of use of such information nor for any infringement of patents or other rights of third parties which may result from its use. No license is granted by implication or otherwise under any patent or patent rights of STMicroelectronics. Specifications mentioned in this publication are subject to change without notice. This publication supersedes and replaces all information previously supplied. STMicroelectronics products are not authorized for use as critical components in life support devices or systems without express written approval of STMicroelectronics.

The ST logo is registered trademark of STMicroelectronics
All other names are the property of their respective owners

© 2002 STMicroelectronics - All Rights Reserved

STMicroelectronics GROUP OF COMPANIES

Australia - Brazil - Canada - China - Finland - France - Germany - Hong Kong - India - Israel - Italy - Japan - Malaysia - Malta -
Morocco - Singapore - Spain - Sweden - Switzerland - United Kingdom - United States

www.st.com