

**DESCRIPTION**

This M63015FP is 1 chip driver IC for spindle motor and 4 channel actuators. All of the motor and actuator of optical disk drive system (CD-ROM etc.) can be driven by only this IC.

This IC has current control drive system for Focus, Tracking, Spindle and Slide channel drive, also has a direct PWM control system for Spindle and Slide channels drive due to reducing IC power dissipation.

This IC has three voltage supply terminals (for Spindle, Slide/Loading and Focus/Tracking), and these voltage supply can be set separately.

Further more this IC has an operational amplifier for Slide input, FG amplifier, thermal shut down circuit, standby circuit, channel select function, reverse rotation detect circuit and Short braking select.

**APPLICATION**

CD-ROM, DVD, DVD-ROM, DVD-RAM, Optical disc related system, etc.

**PIN CONFIGURATION (TOP VIEW)**

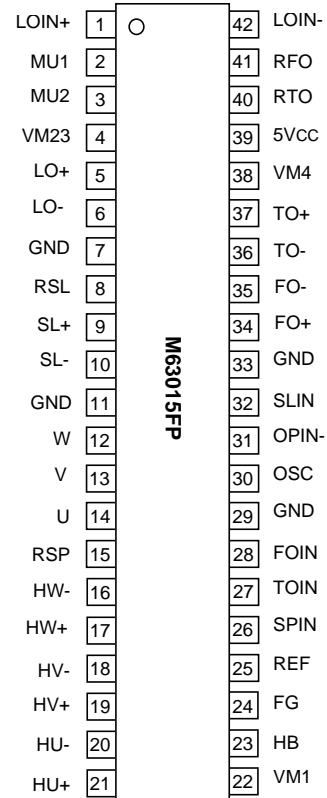

Outline 42P9R-K/B

**BLOCK DIAGRAM**

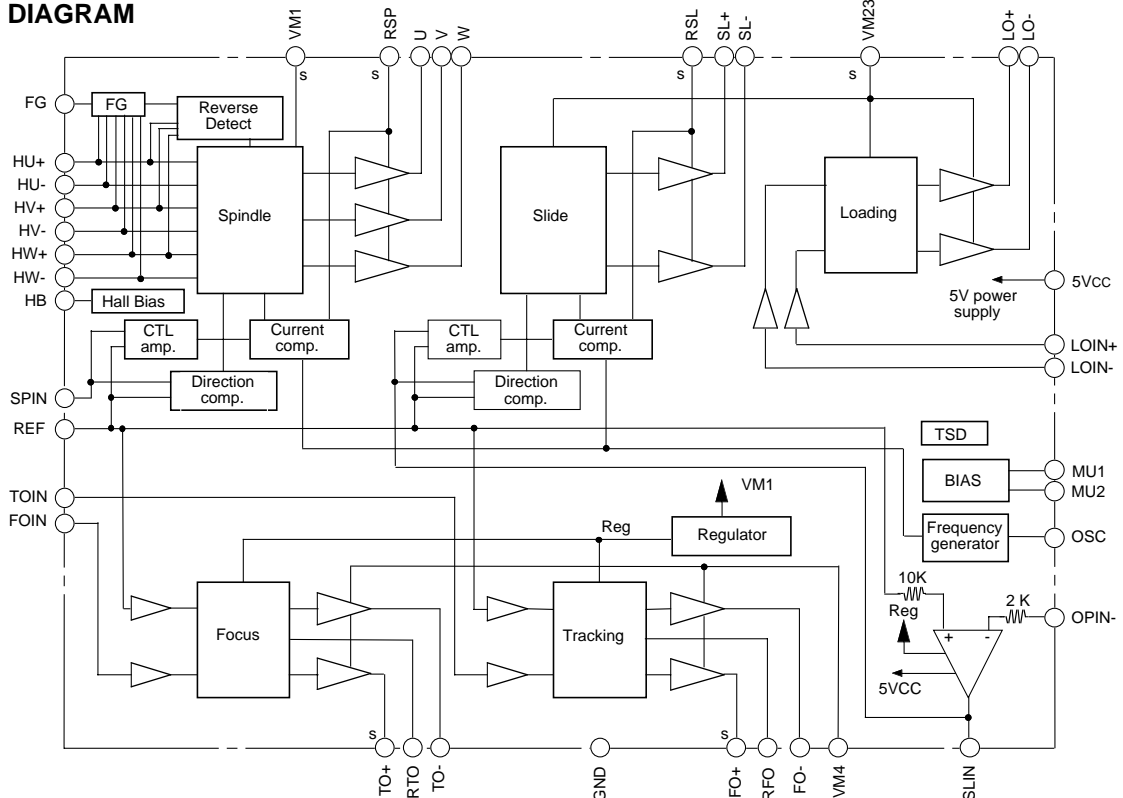

## SPINDLE MOTOR AND 4CH ACTUATOR DRIVER

## DESCRIPTIN OF PIN

Pin No.	Symbol	Function	Pin No.	Symbol	Function
1	LOIN+	Loading control input(+)	42	LOIN-	Loading control input(-)
2	MU1	mute 1	41	RFO	Current feedback terminal for Focus
3	MU2	mute 2	40	RTO	Current feedback terminal for Tracking
4	VM23	Motor Power Supply 3(for Slide/Loading)	39	5VCC	5V Power Supply
5	LO+	Loading non-inverted output	38	VM4	Motor Power Supply 4(for FS and TS)
6	LO-	Loading inverted output	37	TO+	Tracking non-inverted output
7	GND	GND	36	TO-	Tracking inverted output
8	RSL	Slide current sense	35	FO-	Focus inverted output
9	SL+	Slide non-inverted output	34	FO+	Focus non-inverted output
10	SL-	Slide inverted output	33	GND	GND
11	GND	GND	32	SLIN	Slide control input
12	W	Motor drive output W	31	OPIN-	Operational amplifier inverted input
13	V	Motor drive output V	30	OSC	PWM carrier oscilation set
14	U	Motor drive output U	29	GND	GND
15	RSP	Spindle current sense	28	FOIN	Focus control voltage input
16	HW-	HW- sensor amp. input	27	TOIN	Tracking control voltage input
17	HW+	HW+ sensor amp. input	26	SPIN	Spindle control voltage input
18	HV-	HV- sensor amp. input	25	REF	Reference voltage input
19	HV+	HV+ sensor amp. input	24	FG	Frequency generator output
20	HU-	HU- sensor amp. input	23	HB	Bias for Hall Sensor
21	HU+	HU+ sensor amp. input	22	VM1	Motor Power Supply 1(for Spindle)

## ABSOLUTE MAXIMUM RATINGS (Ta=25°C, unless otherwise noted)

Symbol	Parameter	Conditions	Ratings	Unit
5Vcc	5V power supply		7	V
VM1	Motor power supply 1	Spindle power supply	15	V
VM23	Motor power supply 23	Slide and loading power supply	15	V
VM4	Motor power supply 4	Focus and tracking power supply	15	V
IoA	Motor output current A	Spindle output current Note1	1.5	A
IoB	Motor output current B	Slide output current Note1	1.0	A
IoC	Motor output current C	Focus,Tracking and Loading output current Note1	1.0	A
Vin	Maximum input voltage of terminals	MU1,MU2,Hw-,Hw+,Hv-,Hv+,Hu-,Hu+,REF,SPIN, TOIN, FOIN, OSC,OPIN-,LOIN-,LOIN+	0~5Vcc	V
Pt	Power dissipation	Free air and on the grass epoxy board 70mmX70mmX1.6mm	2.6	W
Kq	Thermal derating	Free air and on the grass epoxy board 70mmX70mmX1.6mm	20.8	mW/°C
Tj	Junction temperature		150	°C
Topr	Operating temperature		-20~+75	°C
Tstg	Storage temperature		-40~+150	°C

Note 1 : The ICs must be operated within the Pt (power dissipation) or the area of safety operation.

## RECOMMENDED OPERATING CONDITIONS (Ta=25°C, unless otherwise noted)

Symbol	Parameter	Limits			Unit
		min.	typ.	max.	
VM1	VM1 power supply (forspindle)	6	12	13.2	V
VM23	VM23 power supply (for slide and loading)	4.5	12	13.2	V
VM4	VM4 power supply (for focus and tracking)	4.5	5	13.2	V
IoA	Spindle and slide output current Note 2	–	0.5	1.0	A
IoB	Focus, tracking and loading output current	–	0.5	0.8	A
Fosc	Focus, tracking and loading output current	30	–	120	kHz

TYPICAL CHARACTERISTICS

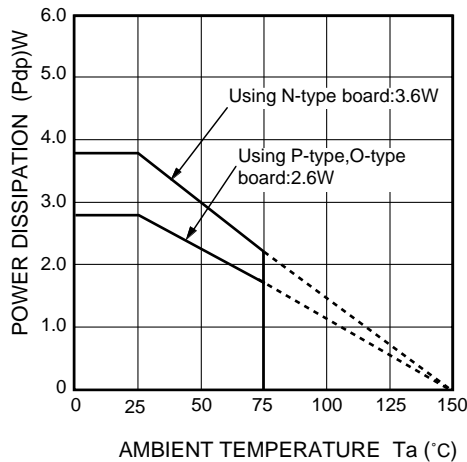

This IC's package is POWER-SSOP, so improving the board on which the IC is mounted enables a large power dissipation without a heat sink. For example, using an 1 layer glass epoxy resin board, the IC's power dissipation is 2.6W at least. And it comes to 3.6W by using an improved 2 layer board. The information of the N, P, O type board is shown in attached.

ELECTRICAL CHARACTERISTICS (Ta=25°C, 5Vcc=VM4=5V, VM1=VM23=12V unless otherwise noted.)

Symbol	Parameter	Test conditions	Limits			Unit	
			Min.	Typ.	Max.		
Common							
Icc1	Supply current	5VCC, VM1, VM23, VM4 current	—	60	78	mA	
Icc2	Sleep current	5VCC, VM1, VM23, VM4 current under Sleep (MU1 = MU2 = 0V).	—	—	30	μA	
Fosc	PWM carrier frequency	OSC : with 180pF	—	110	—	KHz	
VinOP	OPamp input voltage range	OPIN-	-0	—	5	V	
IinOP	OPamp input current	OPIN-=1.65V	-1.0	-0.15	0	μA	
VofOP	OPamp input offset voltage	REF=1.65V(OPIN=-OPOUT ;buffer)	-10	—	+10	mV	
VoutOP	OPamp output voltage range	Io=-2.0~+2.0mA	0.5	—	4.5	V	
VinREF	REF input voltage range		1.0	—	3.3	V	
IinREF	REF input current	VREF=1.65V	-10	—	+10	μA	
VMULO	MUTE terminal low voltage	MU1, MU2	—	—	0.8	V	
VMUHI	MUTE terminal high voltage	MU1, MU2	3.0	—	—	V	
IMU	Mute terminal input current	MU1, MU2 at 5V input voltage	—	—	500	μA	
Spindle							
Vdyc1	Dynamic range of output	Io=0.5 [A]	10.3	10.8	—	V	
Vdead1-	Control voltage dead zone1	SPIN<REF [REVERSE]	-80	-40	0	mV	
Vdead1+		REF<SPIN [FORWARD]	0	+40	+80	mV	
Vin1	Control voltage input range 1	SPIN	0	—	5	V	
Gvo1	Control gain 1	Gio1=Gvo1/ Rs [A/V]	0.85	1.0	1.15	V/V	
Vlim1F	Control limit 1F	Ilim1F=Vlim1F/ Rs [A] [FORWARD]	0.4	0.5	0.6	V	
Vlim1R	Control limit 1R	Ilim1R=Vlim1R/ Rs [A] [REVERSE]	0.27	0.34	0.41	V	
VHcom	Hall sensor amp.common mode input range	Hu+,Hu-,Hv+,Hv-,Hw+, ,Hw-	1.3	—	3.7	V	
VHmin	Hall sensor amp.input signal level	Hu+,Hu-,Hv+,Hv-,Hw+, ,Hw-	60	—	—	mVp-p	
VHB	HB output voltage	at Load current (IHB)=10mA	0.6	0.85	1.2	V	
IHB	HB terminal sink current	MU1=MU2=0V or MU1=MU2=5V or MU1=5V/MU2=0V	—	—	30	mV	
FGD	FG duty	at FG frequency=3kHz, hall input signal level 80mVp-p	—	—	30	mV	
Slide							
Vdyc2	Dynamic range of output	Io=0.5 [A]	at VM23=5[V]	3.3	3.8	—	V
			at VM23=12[V]	10.3	10.8	—	
Vdead2-	Control voltage dead zone 2	SLIN < REF	-80	-40	0	mV	
Vdead2+		REF < SLIN	0	+40	+80	mV	
Vin2	Control voltage input range 2	SLIN	0	—	5	V	
Gvo2	Control gain 2	Gio2=Gvo2/ Rs [A/V]	0.85	1.0	1.15	V/V	
Vlim2	Control limit 2	Ilim2=Vlim2/ Rs [A]	0.43	0.5	0.58	V	
Tdon	Output turn-on delay	The time taken to turn on the output after the Rs voltage goes above the command value.	—	1.0	2.0	μsec	
Tdoff	Output turn-off delay	The time taken to turn off the output after the Rs voltage goes down the command value.	—	3.5	7.0	μsec	
Tdsw	Output switching delay	The time when all the output Tr.s are turned off during the switching of the output Tr.	—	5.0	10.0	μsec	
Ileak	Output leak current	MU1=MU2=5v, MU1=MU2=0v	-100	—	100	μA	

SPINDLE MOTOR AND 4CH ACTUATOR DRIVER

**ELECTRICAL CHARACTERISTICS** (Ta=25°C, 5Vcc=VM4=5V,VM1=VM23=12V unless otherwise noted.)(cont.)

Symbol	Parameter	Test conditions	Limits			Unit	
			Min.	Typ.	Max.		
Loading							
Vdyc3	Dynamic range of output	Io=0.5[A]	VM23=5[V]	3.3	3.8	—	V
			VM23=12[V]	10.3	10.8	—	
Vin3	Control voltage input range3	LOIN+,LOIN-	0	—	5	V	
Gvo3	Control gain 3	$\frac{(LO+) - (LO-)}{(LOIN+) - (LOIN-)}$	16.6	18	19.3	dB	
Voff1	Output offset voltage	(LO+) - (LO-)	LOIN+=LOIN-=5V	-100	0	+100	mV
			LOIN+=LOIN-=1.65V	-50	0	+50	mV
Focus/Tracking							
Vdyc4	Dynamic range of output	Io=0.5[A] VM1=12[V]	VM4=5[V]	3.8	4.2	—	V
			VM4=12[V]	6.8	7.6	—	
Vin4	Control voltage input range 4	FOIN,TOIN	0	—	5	V	
Gvo4	Control gain 4	$\frac{RFO (RTO)-FO-(TO-)}{FOIN(TOIN)-REF}$	-6.7	-8.0	-9.4	dB	
Voff 2	Output offset voltage	RFO (RTO)-FO-(TO-) at REF=FOIN(TOIN)=1.65V	-5	0	+5	mV	

**THERMAL CHARACTERISTICS**

Symbol	Parameter	Function start temperature of ic			Function stop temperature of ic			Unit
		Min.	Typ.	Max.	Min.	Typ.	Max.	
TSD	Thermal shut down	—	160	—	—	130	—	°C

● **Channel select function**

	Logic control		Drive channel						Brake select (SPIN<REF)
	MU1	MU2	Loading	Slide	Focus	Tracking	Spindle	Opamp	
SELECT4	H	H	On	On	On	On	On	On	Short
SELECT3	L	H	On	Off	On	On	On	On	Short
SELECT2	H	L	On	On	On	On	On	On	PWM
SELECT1	L	L	Off	Off	Off	Off	Off	Off	-

This IC has two MUTE terminal (MU1 and MU2).

It is possible to control ON / OFF of each channel by external logic inputs.

It has four kinds of function for select. In case of SELECT1, the bias of all circuit becomes OFF.

Therefore, this mode is available in order to reduce the power dissipation when the waiting mode.

In case of SELECT2, it is possible to select the PWM reverse braking to take the brake of Spindle motor.

Also, in case of **SELECT4**, it is possible to select the short braking when in the same.

In case of **SELECT3**, it is possible to do OFF the slide channel.

Regard with making OFF the loading channel in case of **SELECT2**, **SELECT3** and **SELECT4**, please refer to [Loading channel].

SPINDLE MOTOR AND 4CH ACTUATOR DRIVER

● Loading channel

The loading channel is the circuit of BTL voltage drive. This circuit has the referential input. Output swing is determined with  $\Delta V_{in} \times 8$ . Also, it is possible for this channel to use for the slide motor, the focus coil and the tracking coil.

The input terminal is high impedance. It is possible to do variable a gain by external resistor.

The output becomes high impedance in case of both input voltage becomes under 0.5 volts. It is possible for the input terminal to operate from 0 volts. The following table and diagram show an application in case of two MCU port and one MCU port for the loading motor. In case of one MCU port, if use three state port, it is possible for this channel to have the stop function.

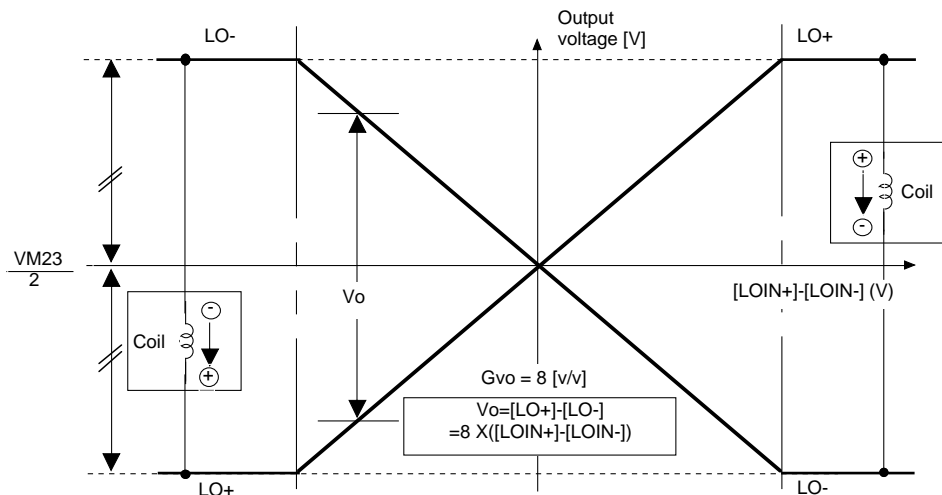
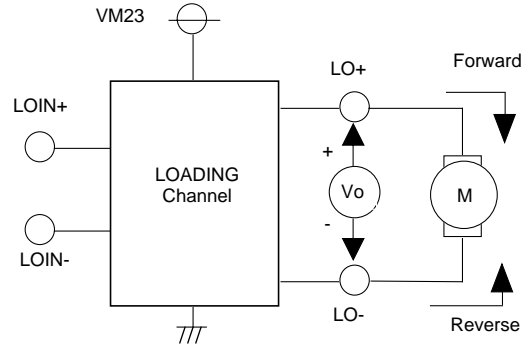

Application.1 (Two port H/L control)

Logic control		Situation of loading channel	Output voltage swing
P1	P2		
5V	5V	Short brake --> Stop	$V_o = 0 [V]$
0	5V	Reverse rotation	$V_o = -8 \times 5 \times R1 / (R1 + 2 \times R2)$
5V	0	Forward rotation	$V_o = 8 \times 5 \times R1 / (R1 + 2 \times R2)$
0	0	Off [ High impedance output]	Off

Application.2 (One port H/L control)

Logic control P1	Situation of loading channel	Output voltage swing
5V	Forward rotation	$\frac{V_o = 2.5[V] \times 8 \times R2}{(R1/2) + R2 + R3}$
Z (Hi impedance)	Short brake --> Stop	$V_o = 0 [V]$
0	Reverse rotation	$\frac{V_o = -2.5[V] \times 8 \times R2}{(R1/2) + R2 + R3}$

SPINDLE MOTOR AND 4CH ACTUATOR DRIVER

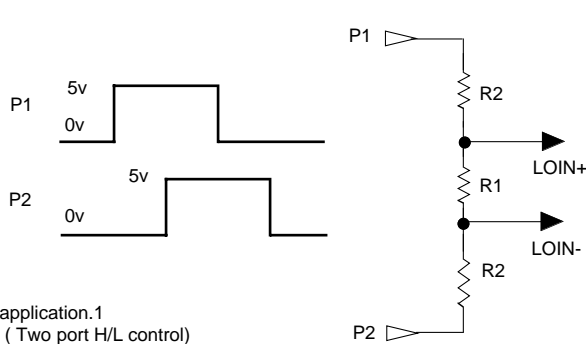

application.1  
(Two port H/L control)

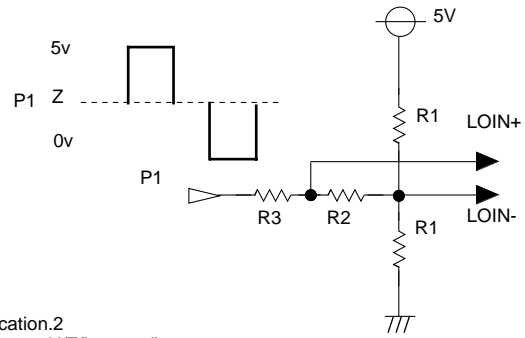

application.2  
(One port H/Z/L control)

● Spindle channel

The relationship between the differential voltage between SPIN and REF and the torque is shown in right Figure. The voltage gain[Gvo] is 1.0 [V/V].

The current gain[Gio] is 2.0A/V (at sensing resistor : 0.5 ohm, and R1=∞,R2=0ohm) in forward torque directions, and the dead zone is from 0mV to 80mV (at R1=∞,R2=0ohm) .

The coil current gain under the reverse torque is the same with in forward torque directions. And the limitation function gets on when the differential voltage of VM1(12V)-RSP is 0.5V at forward and 0.3V at reverse.

Therefore current-gain-control and current-limit of this IC is determined with sensing resistor value, and more detail control can be determined with setting a gain-resistor outer this IC as below.

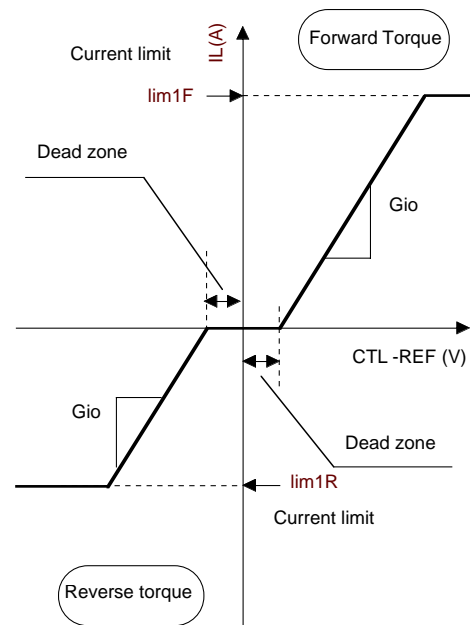

The example of current-gain and current-limit of spindle

Rs [Ω]	Ilim1F [A]	Ilim1R [A]	Gio* [A/V]		
			R1=∞ R2=0 ohm	R1=R2	R1=2•R2
0.50	1.00	0.68	2.00	1.00	0.66
0.75	0.66	0.45	1.33	0.66	0.44
1.00	0.50	0.34	1.00	0.50	0.33

$$Gio^* = R1 / [(R1+R2) \cdot Rs] \text{ [A/V]}$$

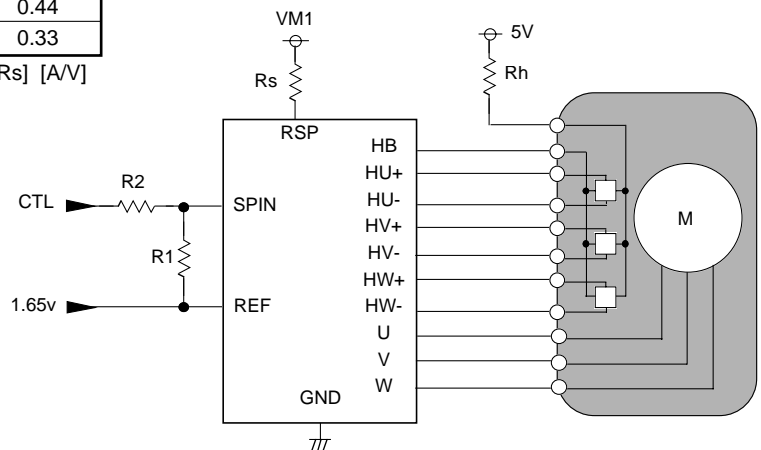

SPINDLE MOTOR AND 4CH ACTUATOR DRIVER

● Slide channel

The relationship between the differential voltage between SLIN and REF and the torque is shown in right Figure. The voltage gain[Gvo] is 1.0 [V/V]. The current gain is 2.0A/V (at sensing resistor : 0.5 ohm and R1=R2) in forward torque directions, and the dead zone is from 0mV to 60mV (at R1=R2=16kohm).

The coil current gain under the reverse torque is the same with in forward torque directions. And the limitation function gets on when the differential voltage of VM23(12V)~RSL is 0.5V.

Therefore current-gain-control and current-limit of this IC is determined with sensing resistor value. In the input part, built-in an inverted amplifier. It is possible to control more detail by setting external circuit.

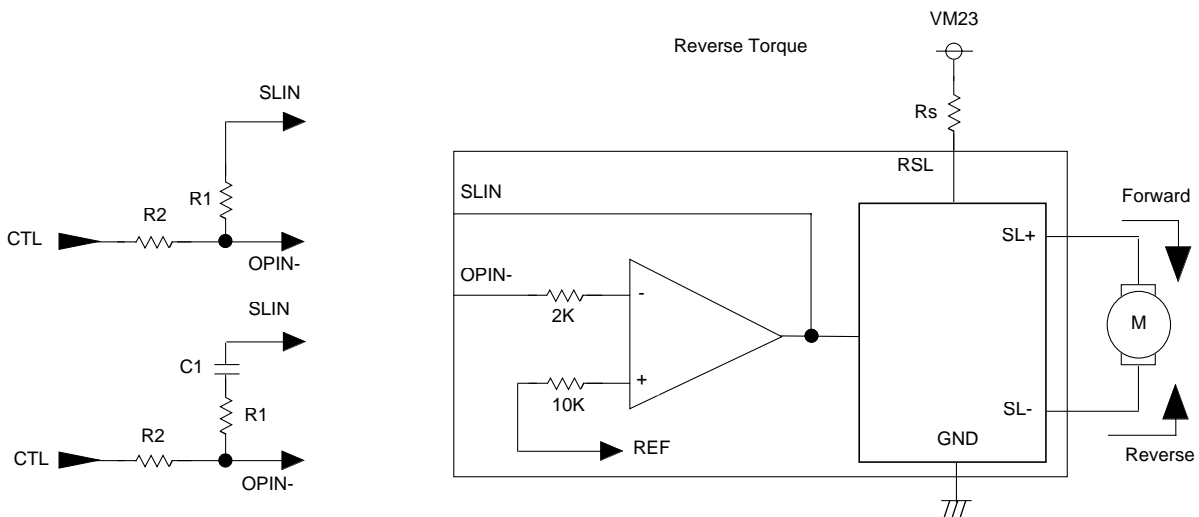
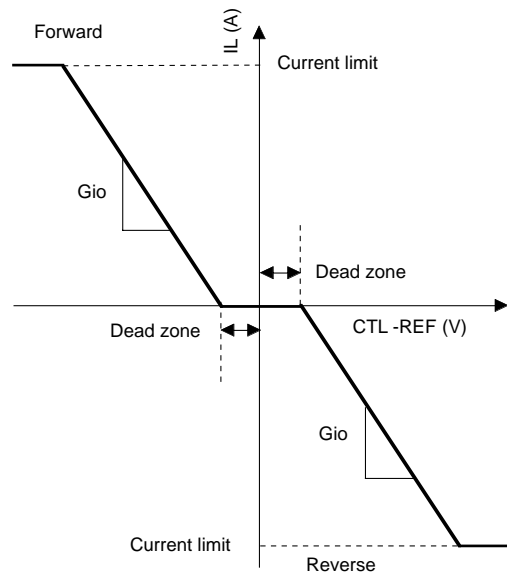

The example of current-gain and current-limit of slide.

Rs [Ω]	Ilim [A]	Gio* [A/V]	
		R1=R2	2•R1=R2
0.50	1.00	2.00	1.00
0.75	0.66	1.33	0.66
1.00	0.50	1.00	0.50

$$Gio^* = R1 / [(R1+R2) \cdot Rs] \text{ [A/V]}$$

The input resistors, the 10kΩ resistor to the non-inverted input and, the 2kΩ resistor to the inverted input, are built-in the operational amplifier. Therefore the composition value of the external input resistors (R1 // R2) should be set 8kΩ because of the compensation for the input offset voltage.

SPINDLE MOTOR AND 4CH ACTUATOR DRIVER

● Focus/tracking channel

The focus and tracking channel is the current feedback control drive of MITSUBISHI original. The focus and tracking is the same composition.

The relationship between the differential voltage between FOIN and REF and the output current is shown in right Figure.

The voltage gain is 0.4 [V/V]. Therefore, the current gain is 0.8[A/V] in case of the sensing resistor is 0.5 ohm.

The maximum range of output swing is limited around 7.5 volts, in case of VM4 is above 10 volts.

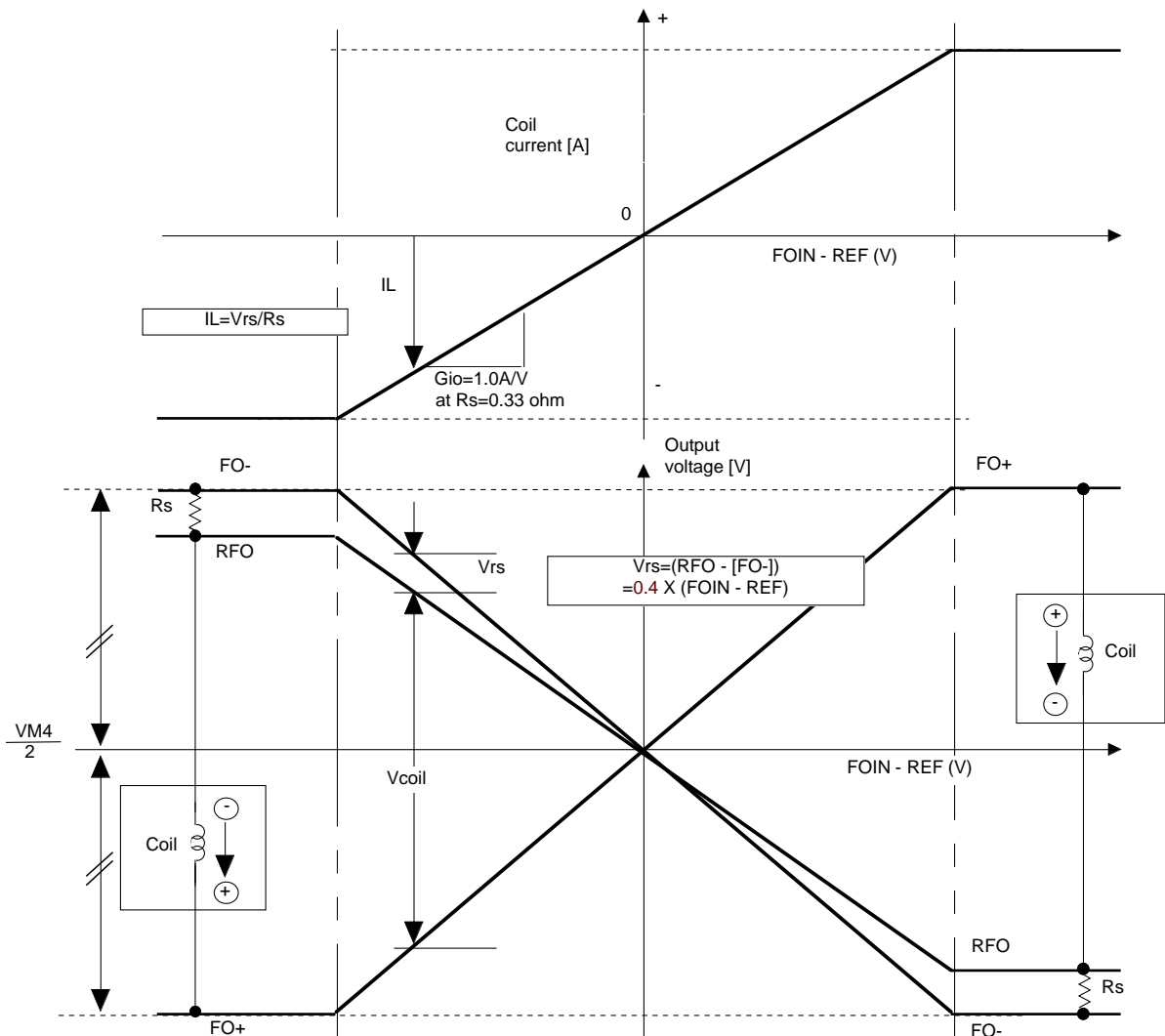
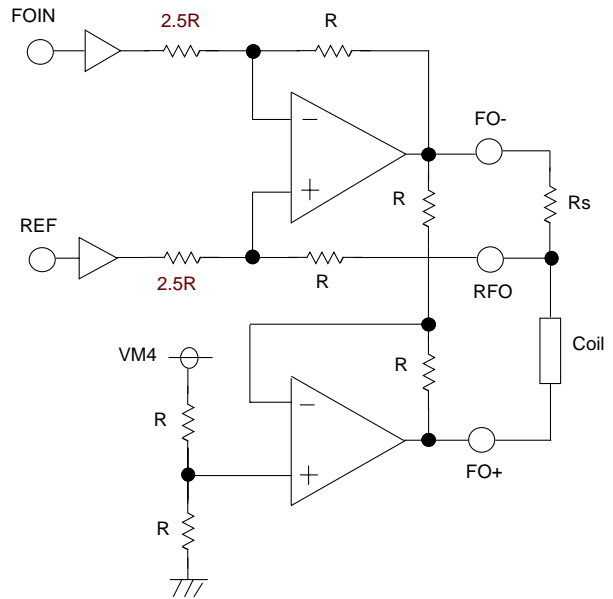



● Direct PWM operation

The spindle and the slide channel is controlled by the direct PWM control.

Also, built-in the current limit circuit. This IC controls the motor current directly.

**FORWARD Current path timing 1.**

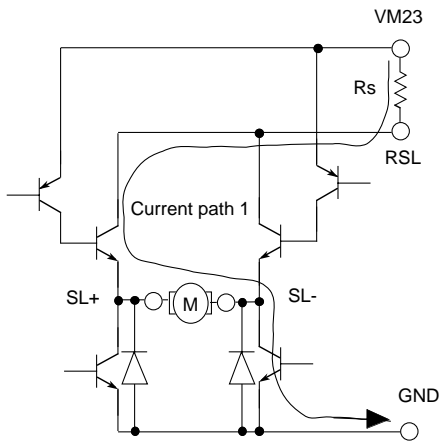

**FORWARD Current path timing 2.**

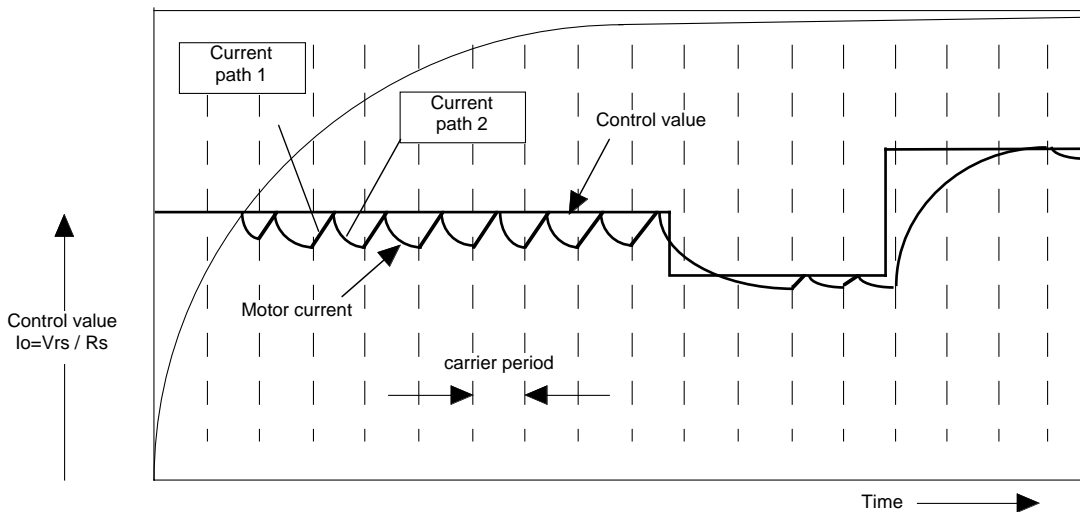
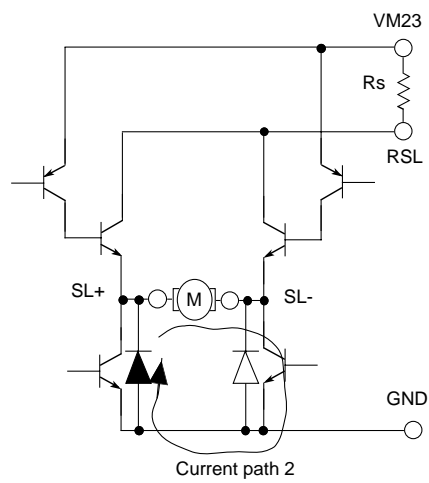

SPINDLE MOTOR AND 4CH ACTUATOR DRIVER

● PWM carrier frequency setting

PWM carrier frequency is decided by charging and discharging the capacitor that is connected to OSC terminal outer IC. Examination of the relationship the capacitor connected to OSC terminal and PWM carrier frequency is given in following table.

Capacitor [pF]	330	220	180	130	110
Carrier Frequency [kHz]	65	90	110	140	160

Note : This PWM carrier frequency is typ value.

● Recommendation of short brake mode at spindle drive

This IC has two brake mode, PWM-BRAKE-MODE and SHORT-BRAKE-MODE. In this IC recommendation, SHORT-BRAKE-MODE is superior to PWM-BRAKE-MODE to reducing the power dissipation and to avoid breaking down of this IC.

(By excessive reverse torque current in braking a motor with PWM-BRAKE from high-speed-rotation with being excessive Back-EMF, this IC could be broken.)

● The relationship between hall-amplifier-input and output-current-commutation/FG output at spindle drive

The relationship between the hall elements, the motor output current and FG output(18pulse/rotation) are shown in bellow Figure.

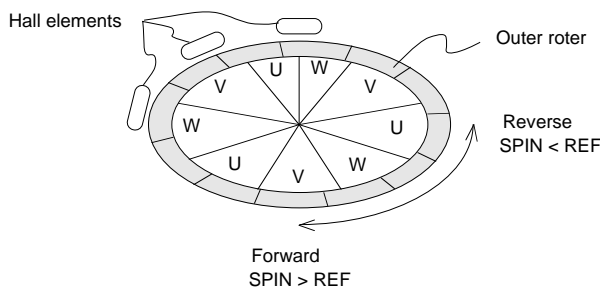
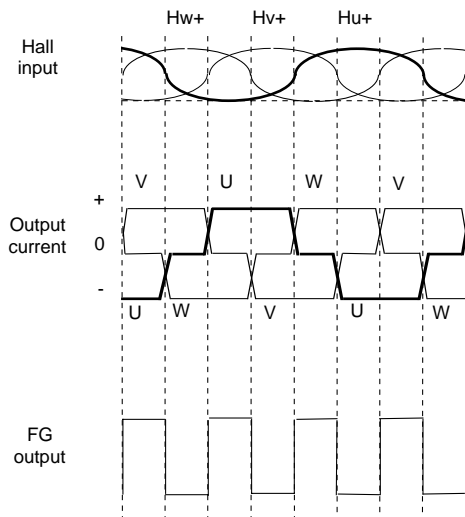

● FG function duty at spindle drive

The FG terminal outputs the square pulse signal synchronizing with the hall inputs (Hu+,Hu-,Hv+, Hv-,Hw+,Hw-) timing. and, the FG terminal is open-collector output. (cf. FG timing chart on the previous page)

● FG function duty at spindle drive

FG function DUTY is shown in a below equation at rihgt Figure.

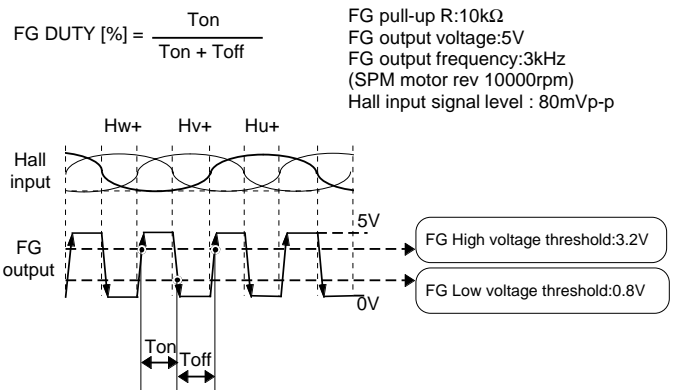

● Phase delay circuit at slide

Phase delay circuit is built in the IC to detect an output spike current, when the motor current direction is switching. In switching the motor current direction, Phase delay circuit switch-off all output tranjister of H-bridge for 3μsec.

● Output current setting at slide

In this IC, since output tranjister is NPN-type tranjister, motor coil current (Io) is larger than sensing resistance current about 20mA (TYP.) according to base current of output tranjister. Therefore please design output current with consisting these base current.

SPINDLE MOTOR AND 4CH ACTUATOR DRIVER

I/O circuit

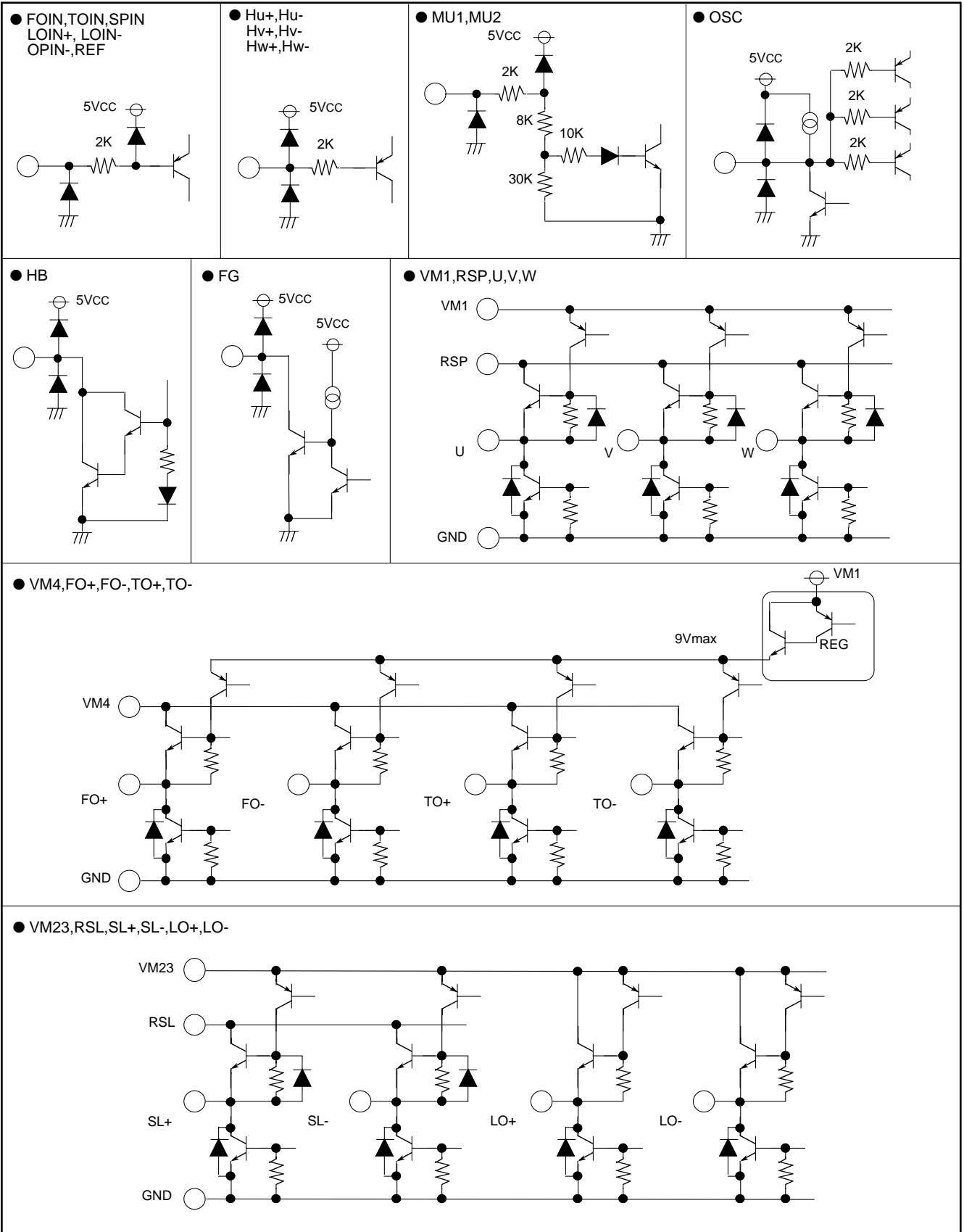

**THE BOARDS FOR THERMAL DERATING EVALUATION**

Board material  
Glass-epoxy FR-4

Size  
70X70mm

thickness  
t=1.6mm

1 and 2 layers  
material : copper  
thickness : t=18μm

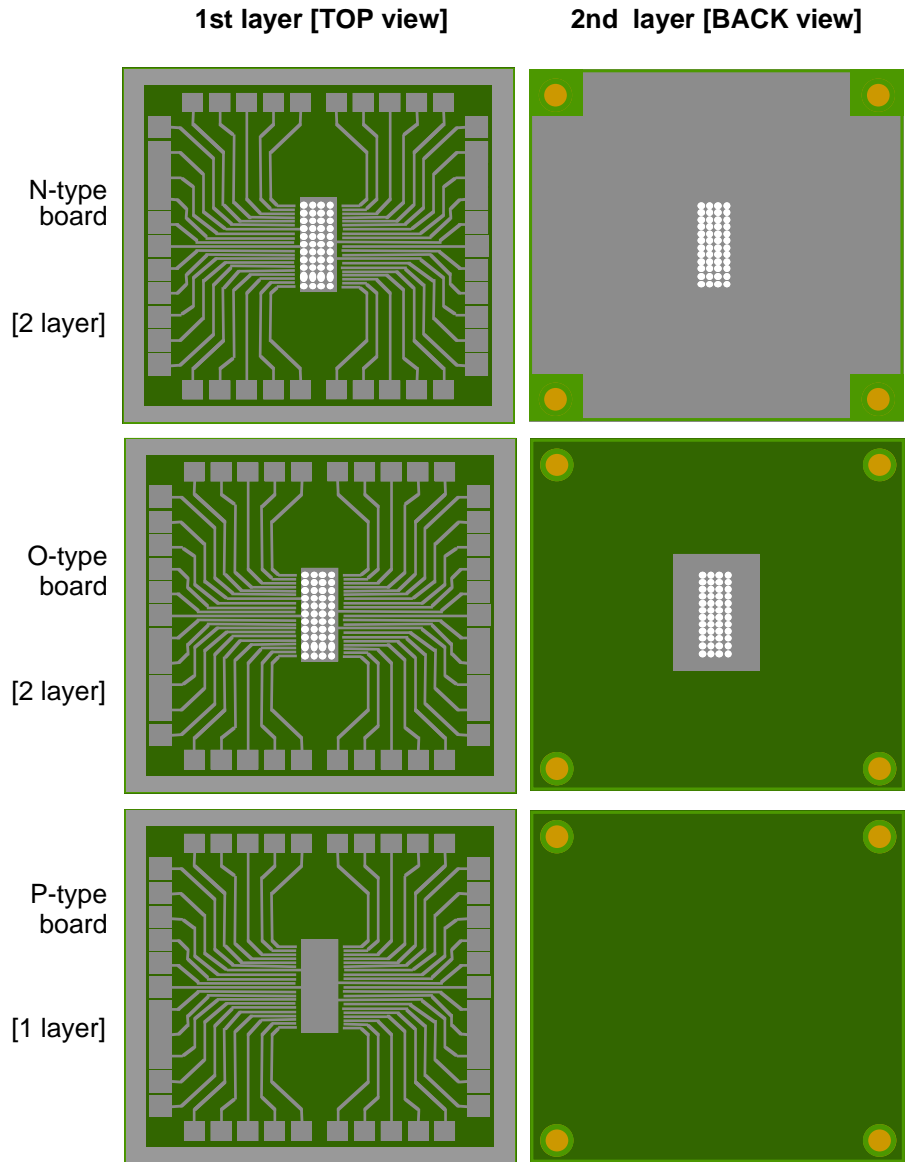
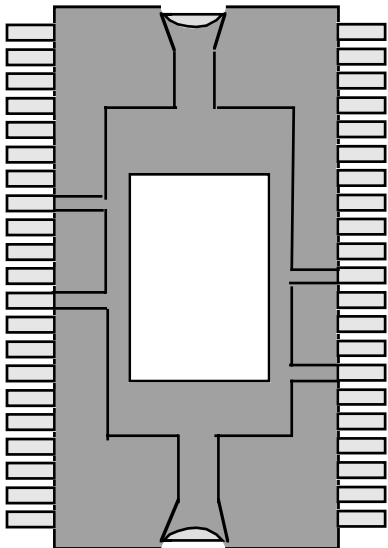

POWER-SSOP 42P9R-K/B

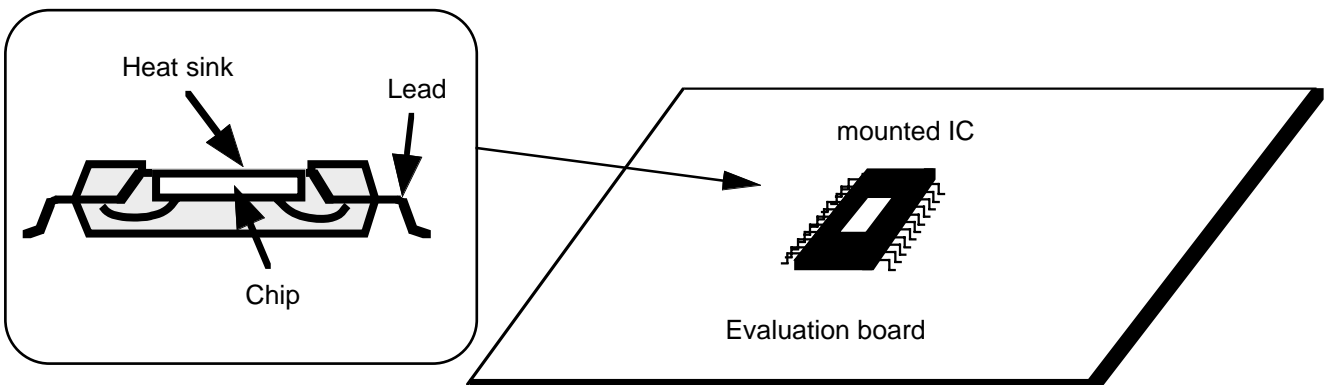

**The notes on designing the layout of the board**

This IC has direct PWM controls for the Spindle channel and the Slide channel drive, therefore the circuits of the IC are influenced more easily by the PWM switching noise than those have linear controls. Please refer to the following notes on the occasion of designing the layout pattern of the board on which the IC is mounted.

The bad influence of the PWM noise differs in each board, therefore please consider the following notes as the reference materials for designing the board.

**Note 1**

It is necessary for some application in order to reduce the PWM noise that pass condensers are connected between power supply pins(VM23:4pin, VM1:22pin, VM4:38 pin, 5VCC:39pin) and GND pin, even if the power supplies of the application already have pass condensers. The closer the connection points of the condensers are to the pins, the more effective it is to reduce the noise.

Please refer to the values of the condensers on the page of [An example of the values of the external parts.

(The value of the condensers is only a reference value. It differs in each application because the bad influence of PWM noise relates to the layout pattern of the board.)

**Note 2**

The feedback point of the Spindle channel [the Slide channel] is the connected point to the VM1(22pin) [the VM23(4pin)] line from the RSP(15pin) [RSL(8pin)] pin through the sensing resistor RSP[RSL]. Therefore the closer the feedback point is to the power supply pin, the more stable the circuits are for the PWM noise.

cf. [application circuit]

**Note 3**

The farther the large current output lines(especially PWM output lines of the Spindle CH. and the Slide CH.) which are indicated as wide lines in the Fig. [application circuit] are to the small signal input lines, the less the bad influence of the PWM noise comes to be without the cross-talk between a large current output line and a small input signal line.

**Note 4**

In case the PWM switching noise influences the REF input, it is necessary for some application that a condenser is connected between REF pin(25pin) and GND pin. The closer the connection points of the condensers are to the pins, the more effective it is to reduce the noise. (This is the same as note1.)

cf.[application circuit], [An example of the values of the external parts]

**Note 5**

The closer the GND side of the capacitor connected with OSC pin (30 pin) is to the GND pin(33pin), which is the nearest GND to the GND of the small signal circuit inside the IC, the less the bad influence of the PWM noise on the GND line comes to be.

cf. [application circuit]

---

APPLICATION EXAMPLE

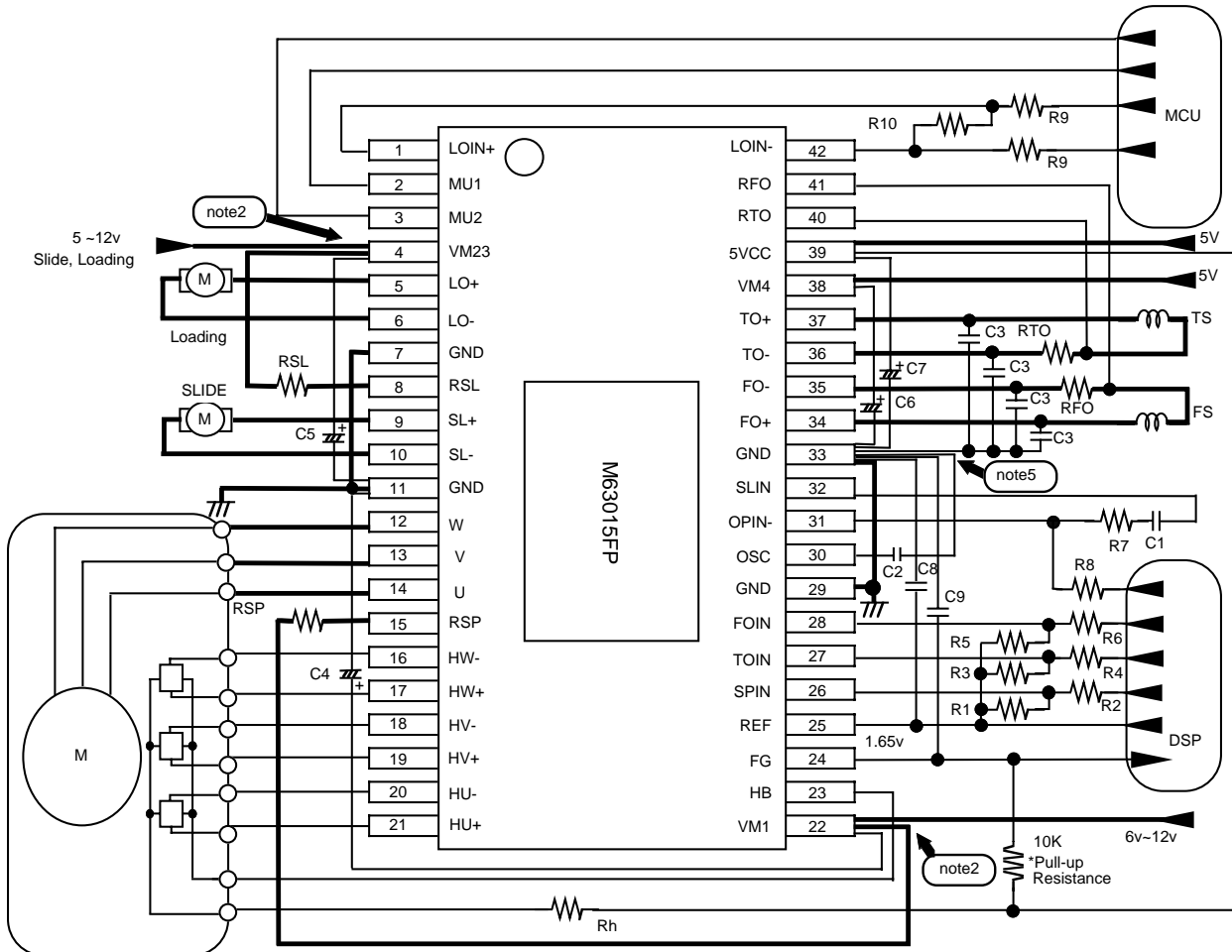

An example of the values of the external parts

These values are only examples, not the guaranteed values. And the values differ in each application.

External parts name	Typ. value	Unit	Note
RSP	0.33	$\Omega$	$I_{lim1F}=1.5[A]$ , $I_{lim1R}=1.0[A]$ , $Gain=3.0[A/V]$
RSL	0.5	$\Omega$	$I_{lim}=1.0[A]$ , $Gain=2.0[A/V]$
RFO, RTO	0.33	$\Omega$	$Gain=1.2[A/V]$
Rh	200	$\Omega$	
R1, R2, R3, R4, R5, R6	10	$k\Omega$	
R7, R8	10	$k\Omega$	
R9, R10	10	$k\Omega$	
C1	330	pF	
C2	180	pF	$F_{osc}=110kHz$
C3	0.1-0.01	$\mu F$	Capacitors against output oscillation in a cold atmosphere. (The capacitors are not necessary in some application)
C4, C5, C6, C7	10-33	$\mu F$	Pass condenser for power supply Note 1
C8	0.1	$\mu F$	REF input noise filter condenser (The capacitors are not necessary in some application) Note 4
C9	470	pF	FG output noise filter condenser (The capacitors are not necessary in some application)

**PACKAGE OUTLINE**

**42P9R-B**

Plastic 42pin 450mil HSSOP

