

# MITSUBISHI INTEGRATED CIRCUIT M64080GP

MITSUBISHI ELEK (LINEAR)

## 410MHz 2SYSTEM 1CHIP PLL FREQUENCY SYNTHESIZER

### DESCRIPTION

The M64080GP is a 410MHz band 2 system 1 chip PLL frequency synthesizer. With two built-in PLL systems, it is ideal for cordless phones and dual band transceivers.

Two modulus prescalers of 1/128 and 1/129 are built-in to allow direct input of up to 410MHz.

### FEATURES

- Two built-in PLLs
- 1/128 and 1/129 prescalers ( $f_{max}=410\text{MHz}$ )
- Wide range of operating voltage ( $V_{CC}=1.8\text{V}$  to  $3.3\text{V}$ )
- Low current consumption
  - When the two PLLs are operating :  $I_{CC}=8\text{mA}$  at  $V_{CC}=2\text{V}$
  - When one is not operating :  $I_{CC}=5\text{mA}$  at  $V_{CC}=2\text{V}$
  - When both are not operating :  $I_{CC}=0.3\text{mA}$  at  $V_{CC}=2\text{V}$
- Divider for reference frequency is also programmable. Setting range of dividing ratio  $N(f_{REF})=128$  to  $16,382$  (Can be set in multiples of 2)
- Programmable divider for local oscillator  
Setting range of dividing ratio  $N(V.C.O)=16,384 \sim 131,071$  (Can be set in integral multiples.)
- Serial data input system (3 data transmission lines)
- PLL lock/unlock status indication function
- Two PLLs can be turned on/off independently with data from controller.
- Two transistor circuits for LPF.

### PIN CONFIGURATION (TOP VIEW)

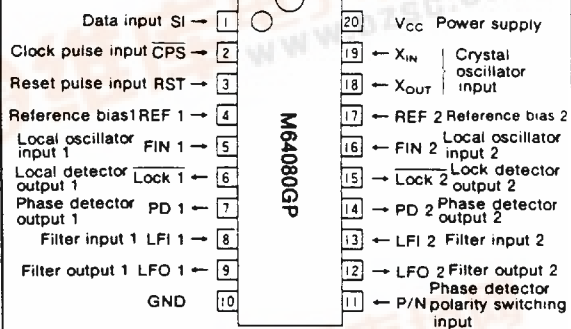

Outline 20P2E-A (20SSOP)

### APPLICATION

Cordless phone, wireless phone, etc.

### BLOCK DIAGRAM

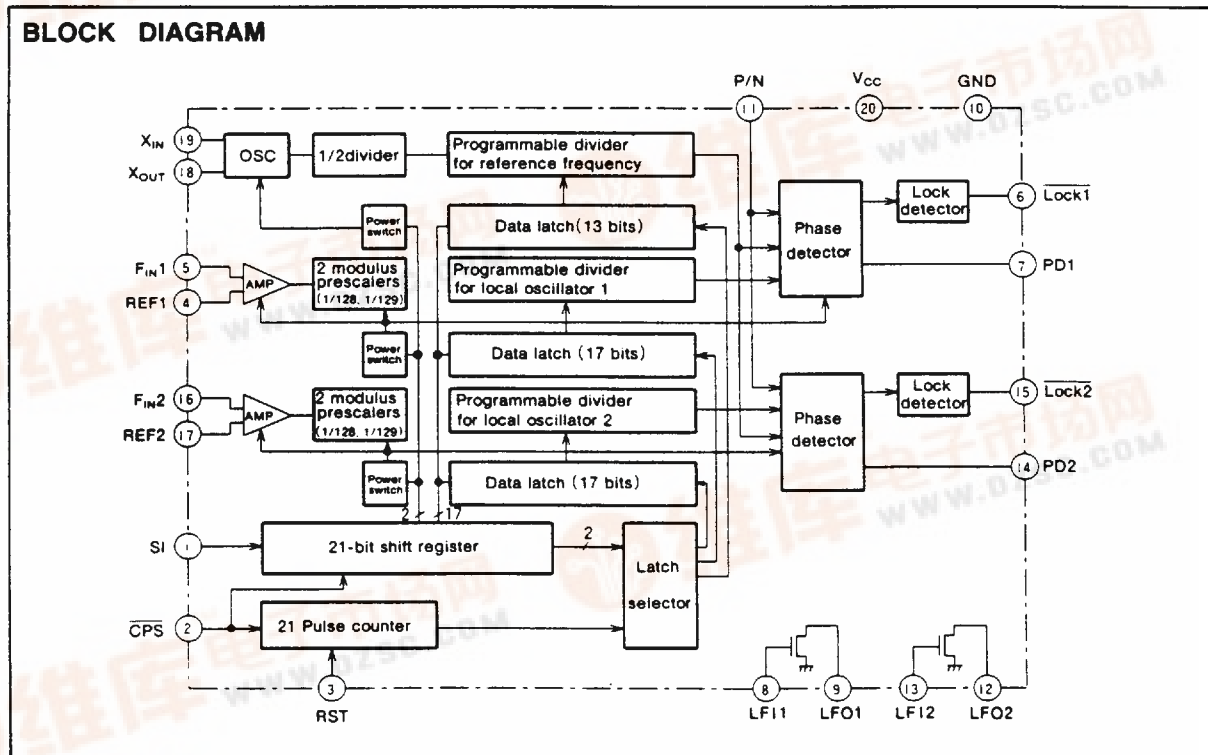

MITSUBISHI ELEK (LINEAR)

**410MHz 2SYSTEM 1CHIP PLL FREQUENCY SYNTHESIZER**
**PIN DESCRIPTION**

Pin no.	Symbol	Pin name	Description
1	SI	Data input	Shift register data input pin
2	$\overline{\text{CPS}}$	Clock pulse input	Shift register clock pulse input pin
3	RST	Reset pulse input	21 pulse counter reset pulse input pin
4	REF 1	Reference bias 1	Grounded with 1000pF capacitor
5	F <sub>IN</sub> 1	Local oscillator input 1	Local oscillator frequency (V. C. O) input F <sub>max</sub> =410MHz
6	$\overline{\text{Lock 1}}$	Lock detector output 1	When PLL system is locked : "L" When it is unlocked : "H" PLL 1 power is off : "H" (open drain type)
7	PD 1	Phase detector output 1	Tristate output High Z when PLL 1 power is off
8	LFI 1	Filter input 1	Gate input for LPF transistor
9	LFO 1	Filter output 1	Transistor drain output (open drain type) for LPF
10	GND	Ground	0V
11	P/N	Phase detector polarity switch input	When this pin is "H", PD pin becomes "H" for phase lead and "L" for phase lag. When this pin is "L", PD pin becomes "L" for phase lead and "H" for phase lag.
12	LFO 2	Filter output 2	Transistor drain output (open drain type) for LPF
13	LFI 2	Filter input 2	Transistor gate input for LPF
14	PD 2	Phase detector output	Tristate output High Z when PLL 2 power is off
15	$\overline{\text{Lock 2}}$	Lock detector output 2	When PLL system is locked : "L" When it is unlocked : "H" PLL 2 power is off : "H" (open drain type)
16	F <sub>IN</sub> 2	Local oscillator input 2	Local oscillator frequency (V. C. O) input F <sub>max</sub> =410MHz
17	REF 2	Reference bias 2	Grounded with 1000pF capacitor
18	X <sub>OUT</sub>	Crystal oscillator input	Output from 12.8MHz to 21.25MHz reference oscillator is input to X <sub>IN</sub> . Oscillator by external crystal resonator is available.
19	X <sub>IN</sub>		
20	V <sub>CC</sub>	Power supply pin	1.8V~3.3V

MITSUBISHI ELEK (LINEAR)

410MHz 2SYSTEM 1CHIP PLL FREQUENCY SYNTHESIZER

FUNCTION DESCRIPTION

1. Data input

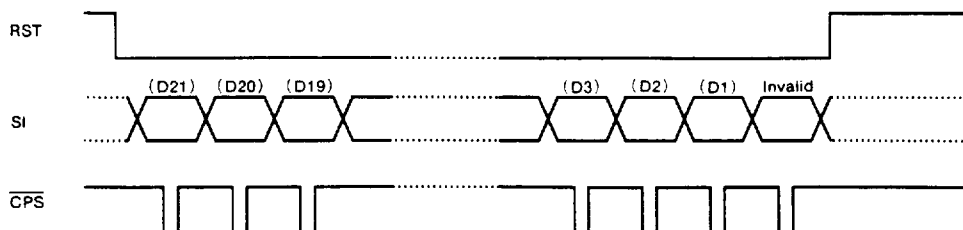

- Note1: SI input status is read into the shift register in sequence at the trailing edge of  $\overline{CPS}$  input.
- 2: All the data (power on/off, latch selector, N value) is set at the trailing edge of the 21st pulse, and subsequent  $\overline{CPS}$  is invalid
- 3: Neither  $\overline{CPS}$  nor SI is accepted while RST is at "H".

2. Input Signal Timing

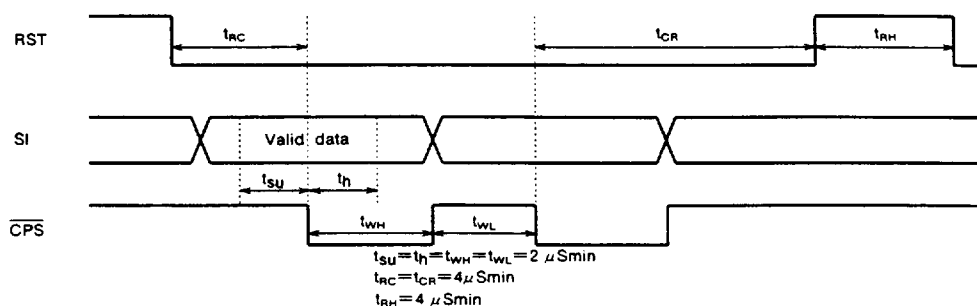

3. Bit Configuration of Shift Register

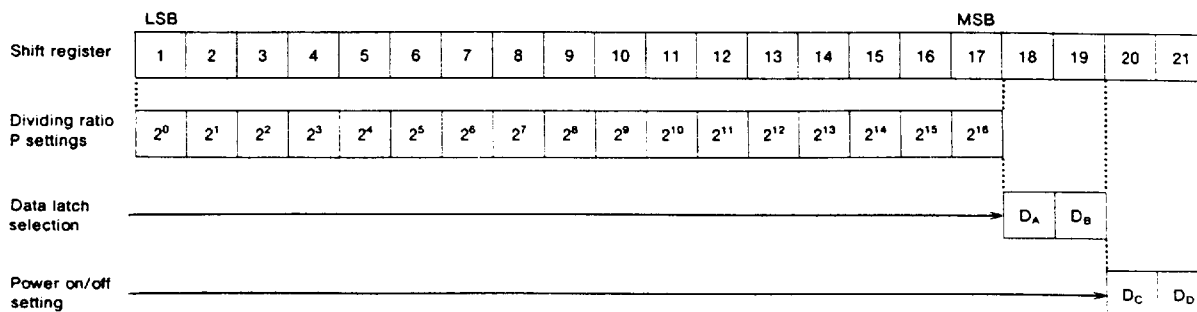

- Note4: Dividing ratio P of the programmable divider is given as 17 bit binary code.  
Total dividing ratio of reference frequency N (f<sub>REF</sub>) is:  
 $N (f_{REF}) = 2 \times P$ , where  $P = 64 \sim 8191$
- Total dividing ratio of local oscillator frequency N (V.C.O) is:  
 $N (V.C.O) = P$ , Where  $P = 16384 \sim 131071$

Note6: Power on/off of PLL system is set by DC and DD.

Note5: Data latch to be updated is selected by DA and DB

Data		Description
D <sub>A</sub>	D <sub>B</sub>	
L	L	This is for test mode. Do not use.
H	L	Data of latch for local oscillator 1 is updated.
L	H	Data of latch for local oscillator 2 is updated.
H	H	Data of latch for reference frequency is updated.

Data		Description
D <sub>C</sub>	D <sub>D</sub>	
L	L	Both local oscillator 1 and local oscillator 2 are on.
H	L	Only local oscillator 1 is on.
L	H	Only local oscillator 2 is on.
H	H	Both oscillators are off.

410MHz 2SYSTEM 1CHIP PLL FREQUENCY SYNTHESIZER

4. Data Coding Example

(1) Set reference frequency to 12.5kHz and local oscillator 1 and 2 to off.

	LSB													MSB							
Shift register	1	2	3	4	5	6	7	8	9	10	11	12	13	14	15	16	17	18	19	20	21
Data	L	H	L	L	H	L	H	L	H	H	L	L	L	X	X	X	X	H	H	H	H

Set dividing ratio p of programmable divider\*  
 $P = 2^1 + 2^4 + 2^6 + 2^8 + 2^9 = 850$

Select updating of data of latch for reference frequency (bits 14-17)  
 Set local oscillator 1 and local oscillator 2 to off. (bits 18-21)

\* : The setting of the dividing ratio P of programmable divider for reference frequency is different from previous series (M54958, M64070, M64072) because a swallow counter is used.

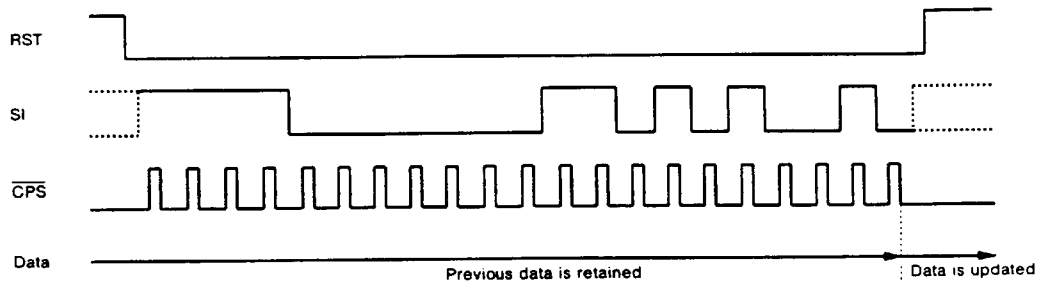

Note7 : Total dividing ratio of reference frequency N ( $f_{REF}$ ) is set at :  $N (f_{REF}) = 2 \times P = 2 \times 850 = 1700$   
 When 21.25 MHz crystal oscillator is used,  $f_{REF} = 21.25 / 1700 = 12.5\text{kHz}$

(2) Set dividing ratio of local oscillator 1 to 24,000 and turn on only local oscillator 1

	LSB													MSB							
Shift register	1	2	3	4	5	6	7	8	9	10	11	12	13	14	15	16	17	18	19	20	21
Data	L	L	L	L	L	L	H	H	H	L	H	H	H	L	H	L	L	H	L	H	L

Setting dividing ratio P of programmable divider  
 $P = 2^6 + 2^7 + 2^8 + 2^{10} + 2^{11} + 2^{12} + 2^{14} = 24,000$

Select update of data of latch for local oscillator 1 (bits 14-17)  
 Turn on power of local oscillator only (bits 18-21)

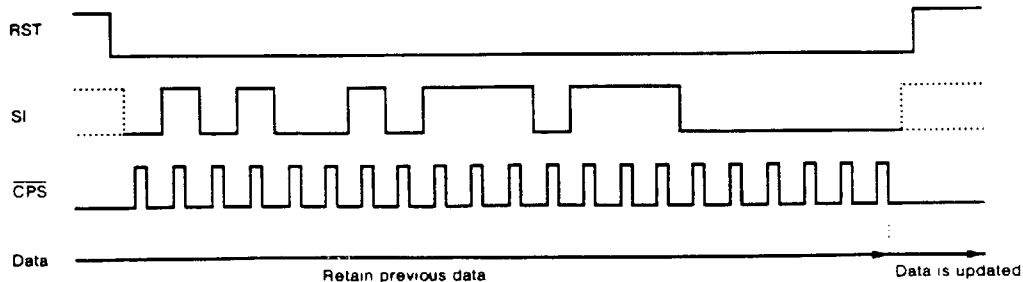

Note8 : If PLL is locked when the reference frequency is set to 12.5 kHz,  
 $f_{VCO1} = 12.5 \times 24,000 = 300,000\text{kHz} = 300\text{MHz}$

MITSUBISHI ELEK (LINEAR)

**410MHz 2SYSTEM 1CHIP PLL FREQUENCY SYNTHESIZER**

**5. PD, Lock Signal Detection**

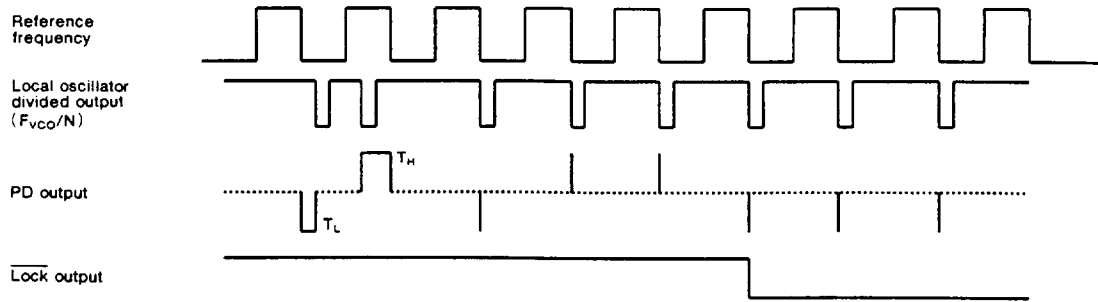

Note9 : PD output becomes "L" when the phase of local oscillator divided output ( $F_{VCO}/N$ ) is behind that of reference frequency ( $f_{REF}$ ) and "H" when it is faster.

10 : ..... indicates high impedance status.

11 : Lock output becomes "L" when the phase differences T<sub>L</sub> and T<sub>H</sub> are kept below 625ns\*\* for more than three cycles of reference frequency ( $f_{REF}$ ).

\* : The above explanation is the case when P/N input (11pin) is at "H".

When P/N input is at "L", polarity of PD output is reversed.

\*\* : It is the case when 12.8MHz oscillator is used for reference oscillator frequency.

MITSUBISHI ELEK (LINEAR)

**410MHz 2SYSTEM 1CHIP PLL FREQUENCY SYNTHESIZER**

**INPUT/OUTPUT CIRCUIT DIAGRAM**

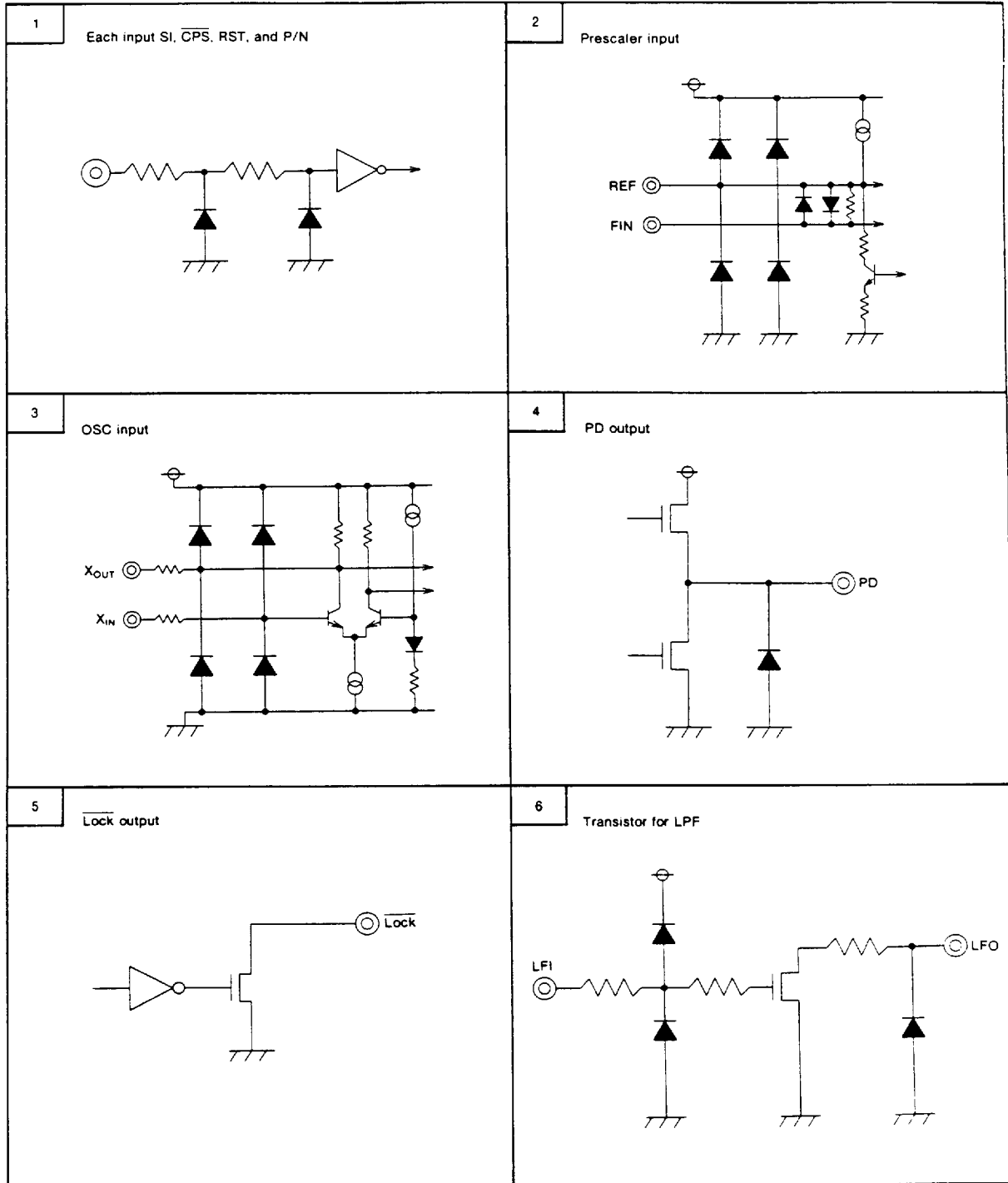

MITSUBISHI ELEK (LINEAR)

**410MHz 2SYSTEM 1CHIP PLL FREQUENCY SYNTHESIZER**

**ABSOLUTE MAXIMUM RATINGS** ( $T_a = -20$  to  $75^\circ\text{C}$ , unless otherwise noted)

Symbol	Parameter	Conditions	Ratings		Unit	Remarks
			Min.	Max.		
$V_{CC}$	Supply voltage	$GND = 0\text{V}$	-0.3	6.0	V	
$V_I$	Input voltage	SI, CPS, RST, $GND = 0\text{V}$	-0.3	6.0	V	
$V_O$	Output voltage	Each output, $GND = 0\text{V}$	-0.3	6.0	V	
$P_d$	Power dissipation	$T_a = 75^\circ\text{C}$		260	mW	Allowable dissipation of package
$V_{opd}$	Open drain voltage	$GND = 0\text{V}$	-0.3	6.0	V	
$T_{opr}$	Operating temperature		-20	75	$^\circ\text{C}$	
$T_{stg}$	Storage temperature		-40	125	$^\circ\text{C}$	

**RECOMMENDED OPERATING CONDITIONS** ( $T_a = -20$  to  $75^\circ\text{C}$ , unless otherwise noted)

Symbol	Parameter	Conditions	Limits			Unit	Remarks
			Min.	Typ.	Max.		
$V_{CC}$	Supply voltage	$F_{IN} = 200 \sim 410\text{MHz}$	1.8		3.3	V	
$V_{IN}$	Input amplitude	$F_{IN} = 200 \sim 410\text{MHz}$	-16		-4	dBm	
$F_{IN}$	Input frequency	$V_{CC} = 1.8 \sim 3.3\text{V}$	200		410	MHz	
$I_{OL}$	Low-level output current	Each output of Lock1, Lock2, LFO1, and LFO2.			1	mA	
$V_{XIN}$	$X_{IN}$ input amplitude	$V_{CC} = 1.8 \sim 3.3\text{V}$ $F_{OSC} = 10 \sim 25\text{MHz}$ sine wave	0.4		1.4	$V_{p-p}$	
$f_{OSC}$	Reference oscillator frequency	$V_{CC} = 1.8 \sim 3.3\text{V}$ $V_{XIN} = 0.4 \sim 1.4V_{p-p}$	10		25	MHz	

**1. Crystal Resonator Connection**

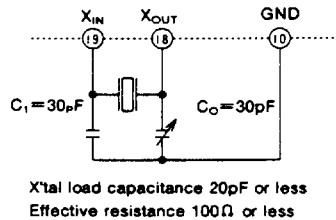

**2. Crystal Oscillator Connection**

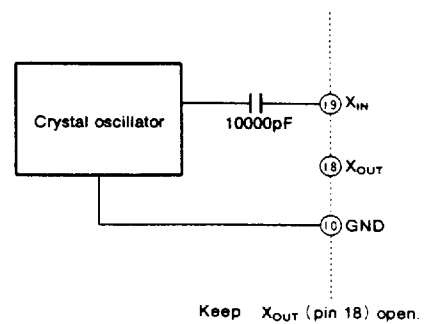

MITSUBISHI ELEK (LINEAR)

**410MHz 2SYSTEM 1CHIP PLL FREQUENCY SYNTHESIZER**

**ELECTRICAL CHARACTERISTICS** ( $T_A = -20$  to  $75^\circ\text{C}$ , unless otherwise noted)

Symbol	Parameter	Pin	condition	Limits			Unit
				Min.	Typ.	Max.	
$V_{IH}$	High-level input voltage	SI, CPS, RST, P/N	$V_{CC} = 1.8 \sim 3.3\text{V}$	$0.7 \times V_{CC}$		5.5	V
$V_{IL}$	Low-level input voltage	SI, CPS, RST, P/N	$V_{CC} = 1.8 \sim 3.3\text{V}$	-0.3		0.6	V
$I_{IH}$	High-level input current	SI, CPS, RST, P/N	$V_{CC} = 3.3\text{V}$ $V_{IH} = 5.5\text{V}$			2	$\mu\text{A}$
$I_{IL}$	Low-level input current	SI, CPS, RST, P/N	$V_{CC} = 3.3\text{V}$ $V_{IL} = 0\text{V}$		-30	2	$\mu\text{A}$
$V_{OL}$	Low-level output voltage	Lock1, Lock2,	$V_{CC} = 1.8 \sim 3.3\text{V}$ $I_O = 0\text{mA}$			0.2	V
$V_{OHP1}$	PD high-level output voltage	PD1, PD2,	$V_{CC} = 3.3\text{V}$ $I_{OH} = -1\text{mA}$	2.5			V
$V_{OHP2}$		PD1, PD2,	$V_{CC} = 1.8\text{V}$ $I_{OH} = -0.1\text{mA}$	1.5			V
$V_{OLP1}$	PD low-level output voltage	PD1, PD2,	$V_{CC} = 3.3\text{V}$ $I_{OL} = 1\text{mA}$			0.8	V
$V_{OLP2}$		PD1, PD2,	$V_{CC} = 1.8\text{V}$ $I_{OL} = 0.1\text{mA}$			0.5	V
$I_{PD1}$	PD leak current	PD1, PD2,	$V_{CC} = 3.3\text{V}$ $V_O = 0 \sim V_{CC}$			$\pm 0.5$	$\mu\text{A}$
$I_{PD2}$		PD1, PD2,	$V_{CC} = 3.3\text{V}$ $V_O = 1.5\text{V}$			$\pm 100$	nA
$I_{CC1}$	Supply current	$V_{CC}$	$V_{CC} = 1.8\text{V}$	5.0	7.5	13.0	mA
$I_{CC2}$		$V_{CC}$	$V_{CC} = 3.3\text{V}$	6.0	9.0	13.0	mA
$I_{OLK}$	Output leak current	Lock1, Lock2, LFO1, LFO2	$V_{CC} = 3.3\text{V}$ , $V_{OH} = 3.3\text{V}$ $LF11 = 0\text{V}$ , $LF12 = 0\text{V}$			$\pm 1.0$	$\mu\text{A}$

Notes : GND pin (pin10) is the reference (0V) for all the voltages.  
 : Current flowing into the circuit is positive (no symbol) and flowing out is negative (-symbol), and maximum and minimum values are indicated in absolute values.  
 : Typical value is measured at  $T_A = 25^\circ\text{C}$ .



MITSUBISHI ELEK (LINEAR)

**410MHz 2SYSTEM 1CHIP PLL FREQUENCY SYNTHESIZER**

**APPLICATION EXAMPLE**

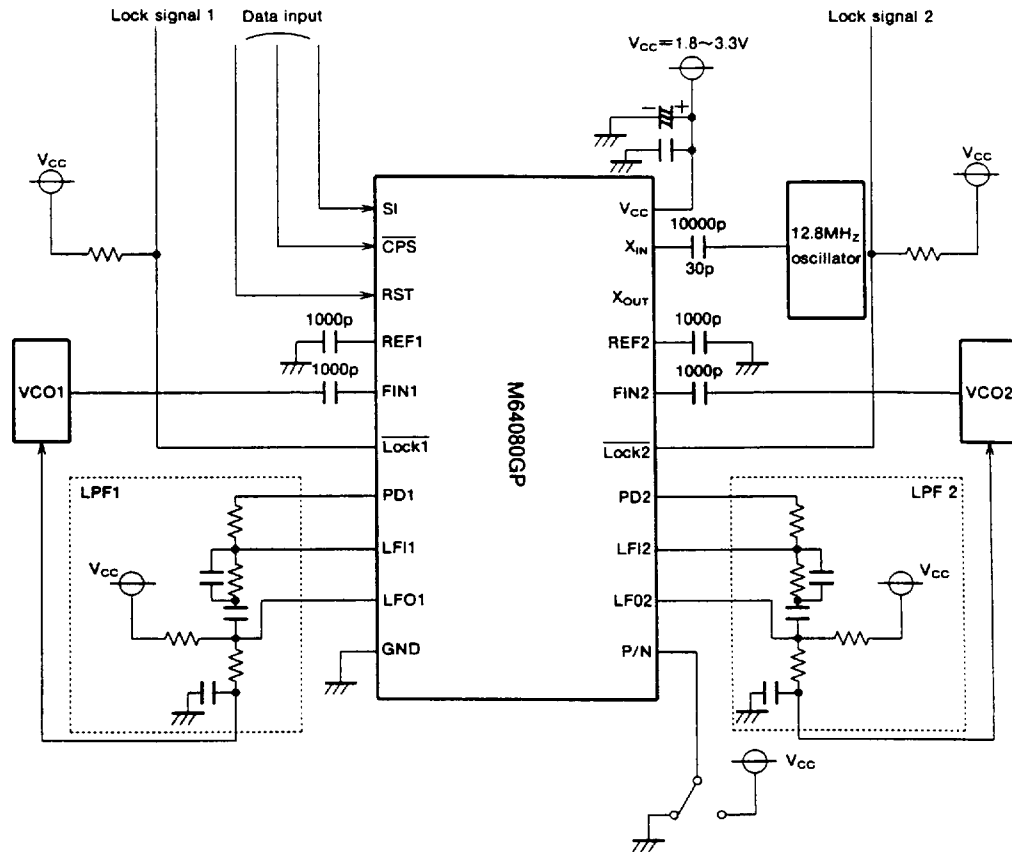

**HANDLING PRECAUTIONS**

This IC contains fine structure components to achieve high performance. Therefore, take extra precaution to protect the IC from surge voltage caused by static electricity.

MITSUBISHI ELEK (LINEAR)

**410MHz 2SYSTEM 1CHIP PLL FREQUENCY SYNTHESIZER**

**PACKAGE OUTLINE**

**20P2E-A**

Plastic 20pin 225mil SSOP

EIAJ Package Code	JEDEC Code	Weight (g)
SSOP020-P-0225	-	0.08

Scale : 4.5/1

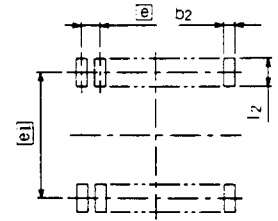
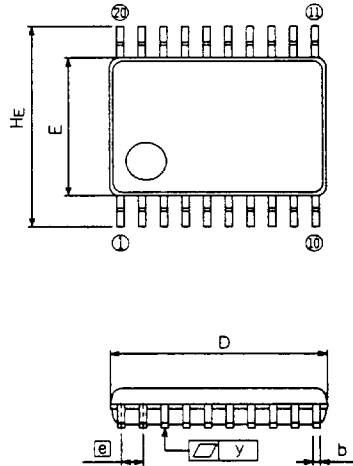

Recommended Mount Pad

Symbol	Dimension in Millimeters		
	Min	Nom	Max
A	-	-	1.45
A1	0	0.1	0.2
A2	-	1.15	-
b	0.17	0.22	0.32
c	0.13	0.15	0.2
D	6.4	6.5	6.6
E	4.3	4.4	4.5
e1	-	0.65	-
HE	6.2	6.4	6.6
L	0.3	0.5	0.7
L1	-	1.0	-
y	-	-	0.1
θ	0°	-	10°
b2	-	0.35	-
e1	-	5.8	-
l2	-	1.0	-