

M66515FP

LASER-DIODE DRIVER/CONTROLLER

DESCRIPTION

The M66515 is a semiconductor laser-diode driver/controller. Its functions are the driving and laser power control of a specific type (Mitsubishi's N type laser) of semiconductor laser diode, in which the anode of a semiconductor laser diode is connected in stem structure to the cathode of a monitoring photodiode.

The IC has a laser drive current output pin of sink type and is capable of driving a laser diode on a maximum bias current of 30mA and a maximum switching current of 120mA, which is switched at a rate of 40Mbit/s.

Since the M66515 has a built in sample-hold circuit, it is possible to realize an internal APC* system that requires no external device for laser power control.

*: Automatic Power Control

FEATURES

- Built-in sample-hold circuit for internal APC function
- High speed switching (40Mbps)
- Large drive current (150mA max.)
- Capable of setting bias current (30mA max.)
- 5V single power supply

APPLICATION

Semiconductor laser-diode applied equipment

PIN CONFIGURATION (TOP VIEW)

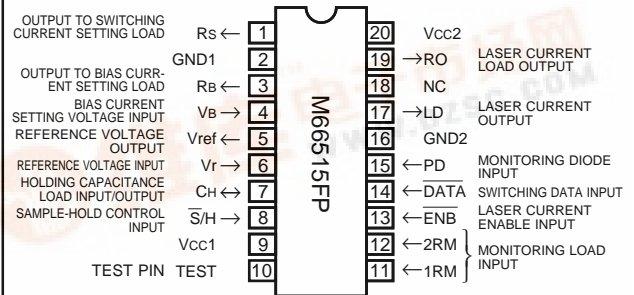

Outline 20P2N-A

NC: No Connection

BLOCK DIAGRAM

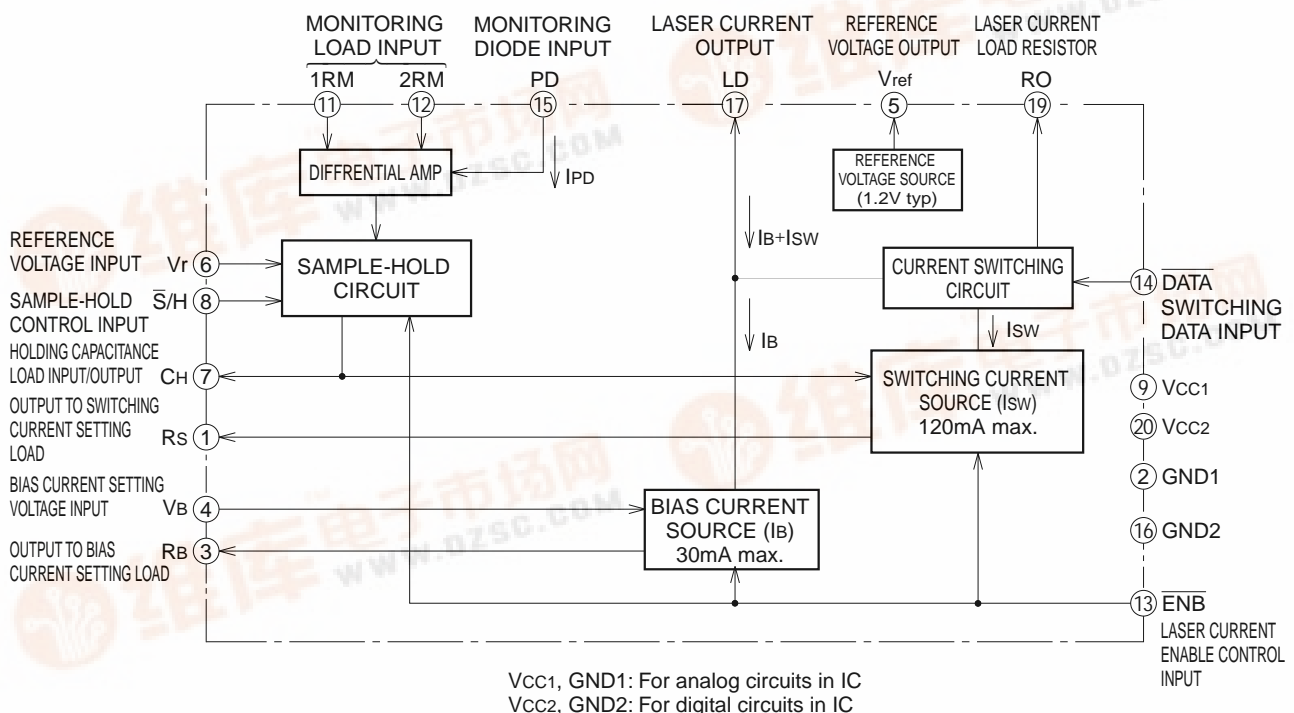

Vcc1, GND1: For analog circuits in IC
Vcc2, GND2: For digital circuits in IC



FUNCTIONS

The M66515 is a semiconductor laser-diode driver/controller. Its functions are the driving and laser power control of a specific type (Mitsubishi's N type laser) of semiconductor laser diode, in which the anode of a semiconductor laser diode (LD) is connected in stem structure to the cathode of a monitoring photodiode (PD).

The functions to drive LD and to control laser power are carried out by connecting an external capacitor to the CH pin and applying a reference voltage to the Vr pin.

The PD current generated by LD illumination flows through the resistor connected between 1RM and 2RM, thereby gen-

erating a potential difference (V_M). V_M is compared with the voltage applied to the Vr pin. If $V_M < V_r$, a constant current is sourced through the CH pin so that the external capacitor is charged. If $V_M > V_r$, a constant current sinks through the CH pin to discharge the external capacitor.

The above operation occurs when the $\overline{S/H}$ input is "L" (sample). When the $\overline{S/H}$ input is "H," the CH pin is maintained at high impedance state (hold), irrespective of the state of V_M , Vr, and \overline{DATA} input.

The LD drive current is made up of the switching current, Isw, which is controlled by the DATA input, and Ib, which is the bias current to LD independent of the state of the \overline{DATA} input.

PIN DESCRIPTIONS

Pin	Name	Description
LD	Laser current output	Connect to cathode on semiconductor laser diode.
PD	Monitoring diode input	Connect to anode on monitoring photodiode.
RS	Switching current Set load output	Connect a load resistor between this pin and GND for the setting of current (Isw) to be switched.
RB	Bias current Set load output	Connect a load resistor between this pin and GND for the setting of bias current (Ib). Leave this pin open if Ib is not used.
VB	Bias current setting voltage input	Bias current (Ib) is set by applying a voltage at this pin. Leave this pin open if Ib is not used.
\overline{DATA}	Switching data input	If this pin is "L," a current of Isw + Ib flows through laser diode; if "H," current Ib flows.
1RM, 2RM	For monitoring Load input	A load resistor is connected between pins 1RM and 2RM for conversion of current generated by monitoring photodiode into changes in voltage.
ENB	Laser current enable input	If this pin is "H" all current source circuits are turned off.
RO	Laser current load output	Connect a laser current load resistor between this pin and Vcc.
S/H	Sample hold control input	If this pin is "L," sampling (APC) occurs, if "H," holding (switching).
CH	Holding capacitor load input/output	Connect a holding capacitor between this pin and GND. Inside the M66515 this pin connects to the output of the sample-hold circuit and the current source input for Isw.
Vref	Reference voltage output	Internal reference voltage (1.2 V typ.) output pin of M66515
Vr	Reference voltage input	A reference voltage is applied to this pin to operate the comparator in the sample-hold circuit. Connect this pin to the Vref pin if the internal reference voltage of the M66515 is to be used.
TEST	Test pin	This pin is used to test the M66515 when shipped. Leave open.
Vcc1	Power supply pin 1	Power supply to internal analog circuits. Connect to a positive power source (+5 V).
Vcc2	Power supply pin 2	Power supply to internal digital circuits. connect to a positive power source (+5 V).
GND1	GND pin 1	GND for internal analog circuits.
GND2	GND pin 2	GND for internal digital circuits.

OPERATION

1. Laser Drive Currents

The approximate values of laser drive currents, I_{SW} and I_B , are obtained by the following equation, in which V_C is the voltage of holding capacitor connected to the CH pin.

(1) I_{SW} (switching current)

$$I_{SW} [mA] = 12 \times \frac{V_C [V]}{R_S [k\Omega]}$$

provided that $0 \leq V_C \leq V_{CC} - 1.8V$ and $I_{SW(max.)} = 120mA$ where R_S is the resistance of the resistor connected between the RS pin and GND.

(2) I_B (bias current)

$$I_B [mA] = 10 \times \frac{V_B [V]}{R_B [k\Omega]}$$

provided that $0 \leq V_B \leq V_{CC} - 2.7V$ and $I_B(max.) = 30mA$ where R_B is the resistance of the resistor connected between the RB pin and GND.

2. Switching Operation

If $\overline{DATA} = "L"$, the LD drive current is $I_{SW} + I_B$; if $\overline{DATA} = "H"$, I_B .

3. ENB Input

When the laser drive current is controlled by the \overline{DATA} input, the M66515's internal current source is maintained turned on. In contrast, the control by \overline{ENB} is turning on and off at the current source. If $\overline{ENB} = "L"$ the current source turns on; if $\overline{ENB} = "H"$ off.

When $\overline{ENB} = "H"$ the CH pin is compulsorily fixed to "L" in order to discharge the capacitor connected to the CH pin.

4. Internal Reset Function

The M66515 has a reset circuit built in for the protection of laser from an excessive current flowing at the moment of power on. The internal current source goes off in the range

$V_{CC} < 3.5V$ (typ.), and the CH pin is compulsorily fixed to "L" at the same time.

5. RO Pin

A load resistor for laser drive current is connected to the RO pin, through which a current almost equal to I_{SW} flows in (when $\overline{DATA} = "H"$). The load resistor is connected between the RO pin and V_{CC} to reduce power dissipated in the IC.

Due to reasons related to the operation of circuits, the voltage at this pin should be 2.5V or higher.

Consequently, the maximum resistance, $RO(max.)$, of load resistor RO is:

$$RO(max.) [\Omega] = \frac{V_{CC(min.)} - 2.5 [V]}{I_{SW(max.)} [A]}$$

where $I_{SW(max.)}$ is the maximum of I_{SW} . If, for example, $V_{CC(min.)} = 4.75V$ and $I_{SW(max.)} = 120mA$, $RO(max.) = 18.8\Omega$.

Accordingly, if the resistance of R_S is selected so as to gain maximum I_{SW} of 120mA, RO should be 18.8Ω at the maximum.

6. Sample-Hold Circuit

(1) Circuit Operation Overview

The following is an overview of the operation of the sample-hold circuit contained in the M66515.

The PD current generated by LD illumination flows through the resistor connected between 1RM and 2RM, thereby generating a potential difference (V_M). V_M is compared with the voltage applied to the Vr pin. If $V_M < V_r$, a constant current is sourced through the CH pin so that the external capacitor is charged. If $V_M > V_r$, a constant current sinks through the CH pin to discharge the external capacitor. This operation occurs when the $\overline{S/H}$ input is "L" (sample). When the $\overline{S/H}$ input is "H," the CH pin is maintained at high impedance state (hold), irrespective of the state of V_M , V_r , and \overline{DATA} input.

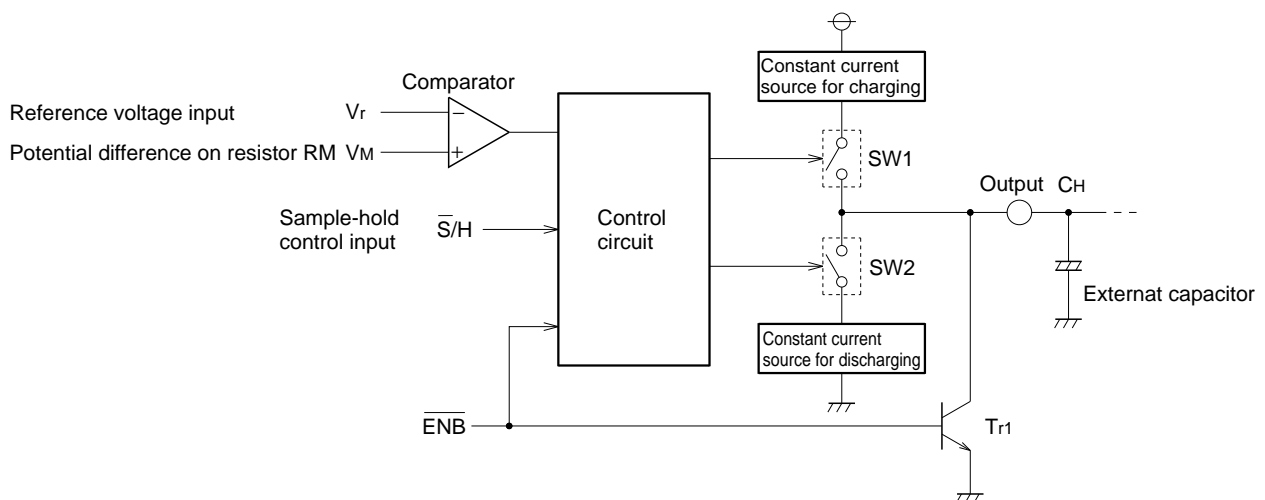

Conceptual Diagram : Sample-Hold circuit

FUNCTION TABLE

Input			Switch condition		Tr1	Output
ENB	S/H	VM, Vr	SW1	SW2		
H	×	×	OFF	OFF	ON	Fixed to "L"
L	H	×	OFF	OFF	OFF	High impedance state (hold)
L	L	VM < Vr	ON	OFF	OFF	Constant current sourcing (sample)
		VM > Vr	OFF	ON	OFF	Constant current sinking (sample)

×: Don't care

(2) APC Timing Chart

The following diagram is an APC timing chart, operation of which is based on sample hold control signals.

Note that in the example it is assumed that the leak current occurring at the CH pin under hold condition flows out from the M66515 (in the negative direction).

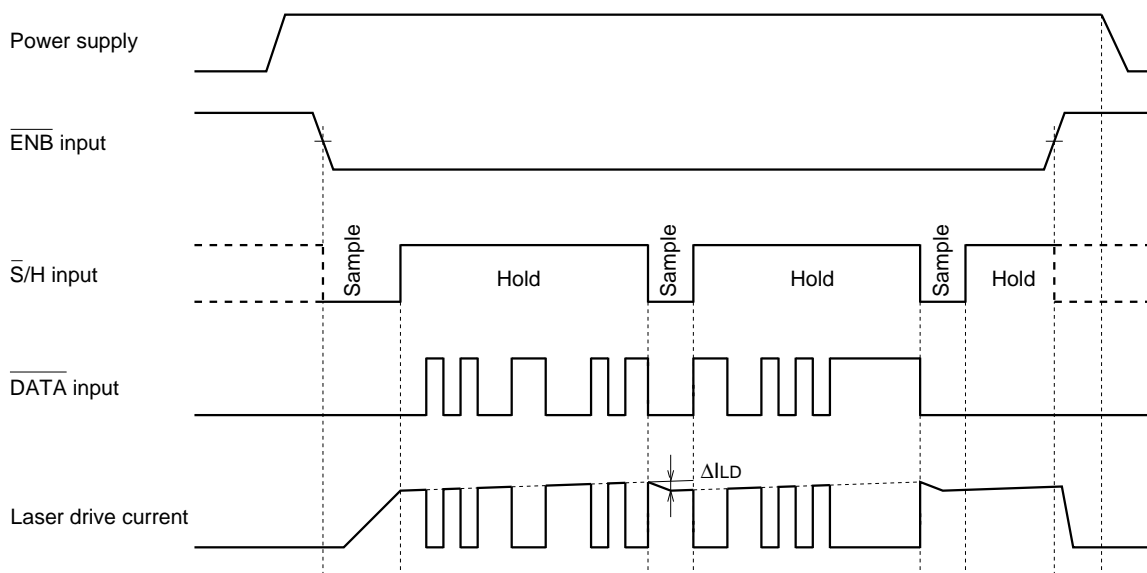

APC Timing Chart

7. Vcc and GND Pins

Pins related to the power supply function are Vcc 1, Vcc 2, GND 1, and GND 2. The role of these pins in terms of the internal circuits are as follows.

Vcc 1, GND 1: connected to analog circuits

Vcc 2, GND 2: connected to digital circuits

In practical wiring, the following should be noted.

- (1) Secure as much a width as possible for conductors and avoid lengthy wiring.
- (2) Allocate electrolytic capacitors for stable voltage near vcc1 and GND 1.
- (3) Allocate by-pass capacitors near Vcc2 and GND 2.

Notes on the Wiring for Peripheral Components

Lay out peripheral components necessary for the M66515 to operate in closest possible proximity to the M66515.

Calculation Method for Power Dissipation

The approximate power dissipation, P, of the M66515FP is determined by the following equation.

$P = I_{cc} \times V_{cc} + I(RO) \times V(RO) + I(LD) \times V(LD)$ where V (RO): voltage at RO pin

V (LD) : voltage at LD pin

I (RO) : load current at RO pin

I (LD) : load current at LD pin

If, for example, Vcc = 5.25V, V (RO) = V (LD) = 2.5V, and I (RO) = I (LD) = 150mA, power dissipation at times of turning laser on and off will be as follows.

(1) Laser ON (DATA = "L" and Icc = 75mA)

$P_{ON} = 75 \times 5.25 + 0 + 150 \times 2.5 = 768.8 \text{ (mW)}$

(2) Laser OFF (DATA = "H" and Icc = 74mA)

$P_{OFF} = 74 \times 5.25 + 150 \times 2.5 + 0 = 763.5 \text{ (mW)}$

ABSOLUTE MAXIMUM RATINGS (Ta = -20 ~ 70°C unless otherwise noted)

Symbol	Parameter	Conditions	Ratings	Unit
VCC	Supply voltage		-0.5 ~ +7.0	V
Vi	Input voltage	CH, Vr	-0.3 ~ VCC	V
		DATA, ENB, S/H	-0.3 ~ +7.0	
Vo	Output voltage	RO	-0.3 ~ +7.0	V
ISW	Switching current		150	mA
IB	Bias current		45	mA
Pd	Power dissipation	Measured being mounted Ta = 25°C	1200	mW
Tstg	Storage temperature		-65 ~ 150	°C

RECOMMENDED OPERATIONAL CONDITIONS (Ta = -20 ~ 70°C unless otherwise noted)

Symbol	Parameter	Limits			Unit
		Min.	Typ.	Max.	
VCC	Supply voltage	4.75	5.0	5.25	V
ISW	Switing current			120	mA
IB	Bias current			30	mA
Topr	Operating ambient temperature	-20		70	°C

ELECTRICAL CHARACTERISTICS (Ta = -20 ~ 70°C, VCC = 5V±5% unless otherwise noted)

Symbol	Parameter	Test conditions	Limits			Unit	Test circuit	
			Min.	Typ.*	Max.			
VIH	"H" Input voltage	DATA, ENB, S/H	2.0			V		
VIL	"L" Input voltage	DATA, ENB, S/H			0.8	V		
Vr	Reference voltage input	Vr	0.4		2.0	V		
Vref	Reference voltage output	Vref	IO = -10μA	1.2		V	1	
		Temperature coefficient	Ta = -20 ~ 25°C	-0.9		mV/°C		
			Ta = 20 ~ 70°C	-0.9				
VLD	Operating voltage range	LD	2.5		VCC	V		
Vi	Maximum effective voltage	CH	VCC - 1.8	VCC - 1.4		V		
VOH	"H" output voltage	CH	ENB = 0.8V, IOH = -2mA	4.0		V	1	
VOL	"L" output voltage	CH	ENB = 0.8V, IOL = 2mA		0.6	V	1	
Ii	Input current	DATA, ENB	Vi = 2.7V		20	μA		
			Vi = 0.4V		-0.2	mA		
		CH	Vi = 0 ~ VCC		±1	μA		
ISW	Switching current (Note)	LD	CH = 3.0V, RS = 300Ω, VLD = 2V	120		mA	2	
			Temperature coefficient	Ta = 20 ~ 70°C	0.11			mA/°C
IB	Bias current (Note)	LD	VB = 1.2V, RB = 360Ω, VLD = 2V	30		mA	2	
Icg	Load charging current	CH	ENB = 0.8V, Vo = 0.6 ~ 4.0V	-0.66	-2.0	mA	3	
I dg	Load discharging current	CH	ENB = 0.8V, Vo = 0.6 ~ 4.0V	0.66	2.0	mA	3	
IoZ	Output current under off condition	CH	Vo = 0 ~ VCC, Hold condition		±5	μA	3	
IOFF	Output current under off condition	LD	ENB = 0.8V, DATA = 2.0V	0.03	50	μA	2	
			ENB = 2.0V, DATA = 0.8V	0.01	50			
ICC	Supply current		VCC = 5.25V, ENB = 0V, CH = 3.0V, VB = 1.2V, RS = 300Ω, RB = 360Ω, RO = LD = 5.0V	DATA = 0V	54	75	mA	4
			DATA = 4.5V	52	74			

* Typical values are gained under conditions of Ta = 25°C and VCC = 5V.

Note: This parameter indicates the conversion characteristics of the input voltage and output current. In actual use, ISW and IB shall be within the range specified as limits in the recommended operating conditions.

SWITCHING CHARACTERISTICS ($T_a = 25^\circ\text{C}$, $V_{CC} = 5\text{V}$)

Symbol	Parameter	Test pin		Test condition	Limits			Unit
		Input	Output		Min.	Typ.	Max.	
fop	Operating frequency					40		Mbps
tRP1	Circuit response time 1	CH voltage	LD current	$I_{LD}(L) = 0\text{mA}$ $I_{LD}(H) = 60\text{mA}$ (Note 1)			7	μs
				$I_{LD}(L) = 55\text{mA}$ $I_{LD}(H) = 65\text{mA}$ (Note 1)			2	
tRP2	Circuit response time 2	PD current	CH voltage	$I_{PD}(L) = 0\text{mA}$ $I_{PD}(H) = 2\text{mA}$ $R_M = 1\text{k}\Omega$ (Note 2)			15	μs
				$ \Delta I_{PD} = 0.2\text{mA}$ $R_M = 1\text{k}\Omega$ (Note 2)			8	
tRP3	Circuit response time 3	$\overline{\text{S/H}}$ voltage	CH voltage	$I_{PD} = 0\text{mA}, 2\text{mA}$, (Note 3) $R_M = 1\text{k}\Omega, V_r = 1.2\text{V}$			8	μs
tON	Circuit ON time	$\overline{\text{ENB}}$ voltage	LD current	$I_{LD}(H) = 60\text{mA}$ (Note 4)			5	μs
tOFF	Circuit OFF time	$\overline{\text{ENB}}$ voltage	LD current	$I_{LD}(H) = 60\text{mA}$ (Note 4)			2	μs

NOTE1: TEST CIRCUIT

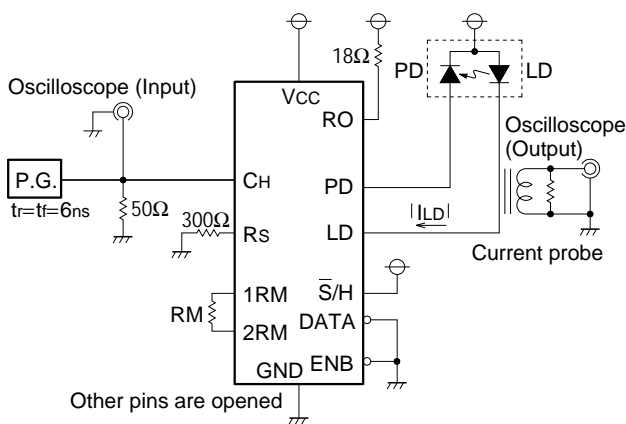

NOTE2: TEST CIRCUIT

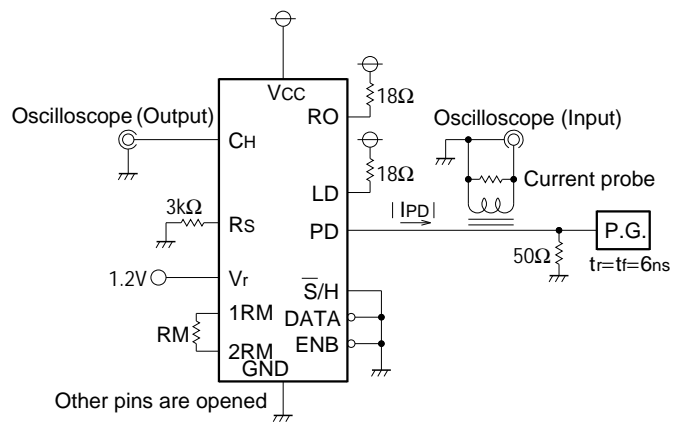

TIMING CHARTS

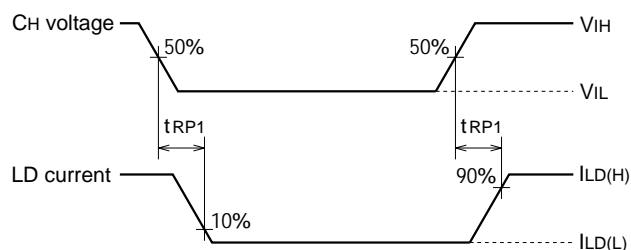

TIMING CHARTS

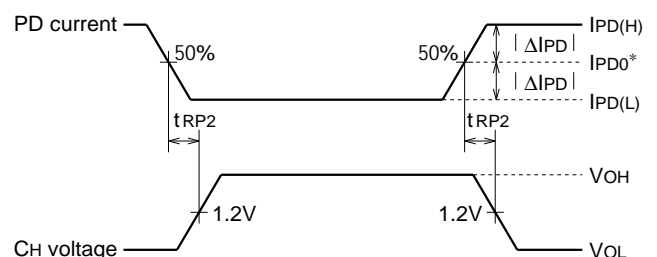

* : I_{PD} gained at the moment CH output is inverted.

NOTE3: TEST CIRCUIT

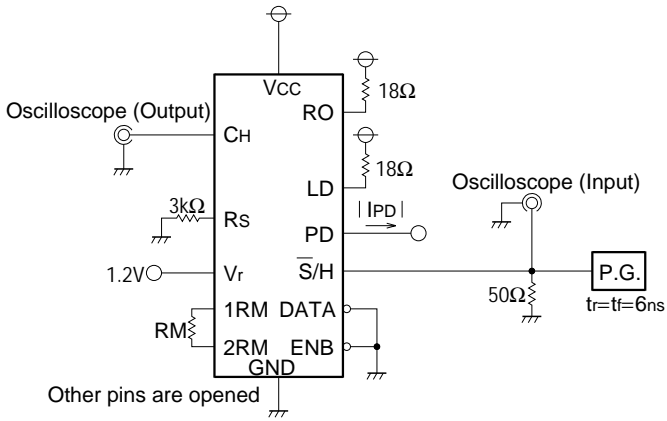

NOTE4: TEST CIRCUIT

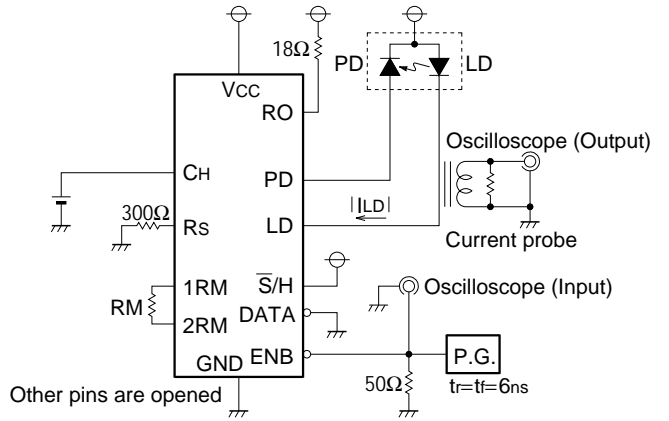

TIMING CHARTS

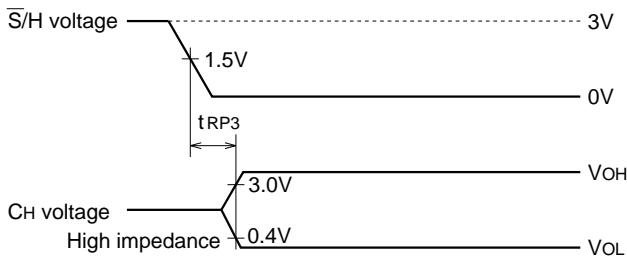

TIMING CHARTS

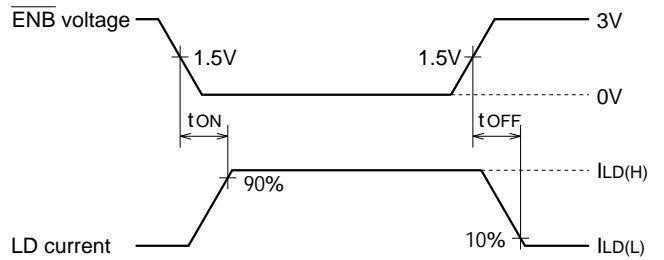

APPLICATION EXAMPLE

