

M67741L

135-160MHz, 12.5V, 30W, FM MOBILE RADIO

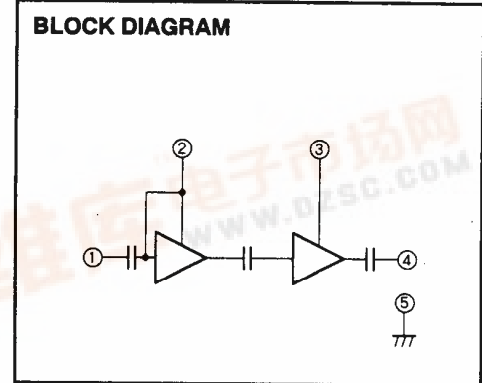
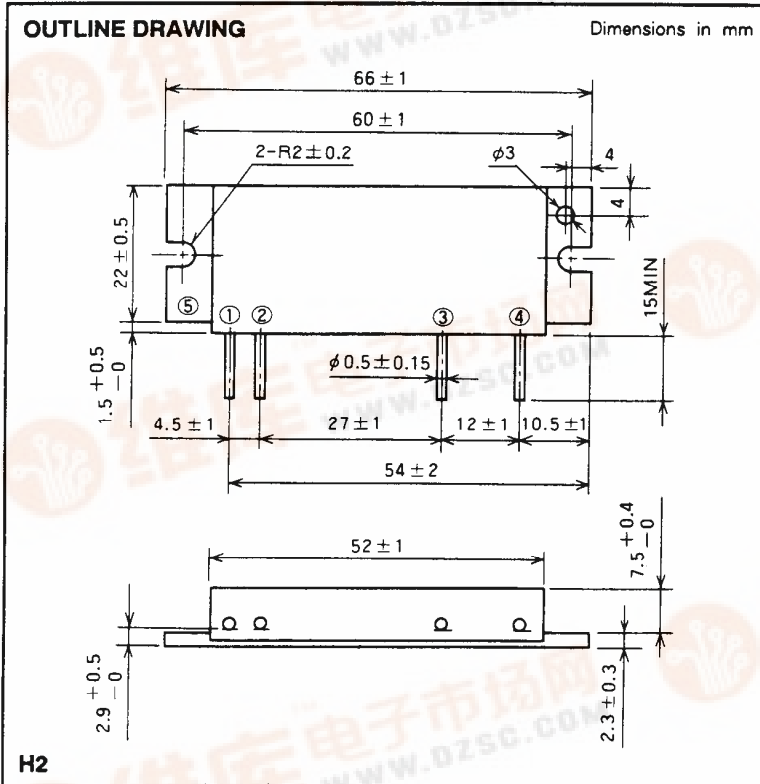

PIN :

- ① Pin : RF INPUT
- ② Vcc1 : 1st. DC SUPPLY
- ③ Vcc2 : 2nd. DC SUPPLY
- ④ Po : RF OUTPUT
- ⑤ GND : FIN

ABSOLUTE MAXIMUM RATINGS (T_c = 25 °C unless otherwise noted)

| Symbol | Parameter | Conditions | Ratings | Unit |
|----------------------|----------------------------|--|-------------|------|
| V _{cc} | Supply voltage | | 17 | V |
| I _{cc} | Total current | | 7 | A |
| P _{in(max)} | Input power | Z _G = Z _L = 50 Ω, V _{cc1} ≤ 12.5V | 0.5 | W |
| P _{o(max)} | Output power | Z _G = Z _L = 50 Ω | 35 | W |
| T _{c(OP)} | Operation case temperature | | - 30 to 110 | °C |
| T _{stg} | Storage temperature | | - 40 to 110 | °C |

Note. Above parameters are guaranteed independently.

ELECTRICAL CHARACTERISTICS (T_c = 25 °C unless otherwise noted)

| Symbol | Parameter | Test conditions | Limits | | Unit |
|-----------------|---------------------|---|---------------------------|------|------|
| | | | Min | Max | |
| f | Frequency range | P _{in} = 0.2W V _{cc} = 12.5V Z _G = Z _L = 50 Ω | 135 | 160 | MHz |
| P _o | Output power | | 30 | | W |
| η _T | Total efficiency | | 40 | | % |
| 2f _o | 2nd. harmonic | | | - 25 | dBc |
| 3f _o | 3rd. harmonic | | | - 30 | dBc |
| ρ _{in} | Input VSWR | | | 3.3 | - |
| - | Load VSWR tolerance | V _{cc} = 15.2V, P _o = 30W (P _{in} : controlled) Load VSWR ≥ 20:1 (All phase), 2sec. Z _G = 50 Ω | No degradation or destroy | | - |

Note. Above parameters, ratings, limits and conditions are subject to change.



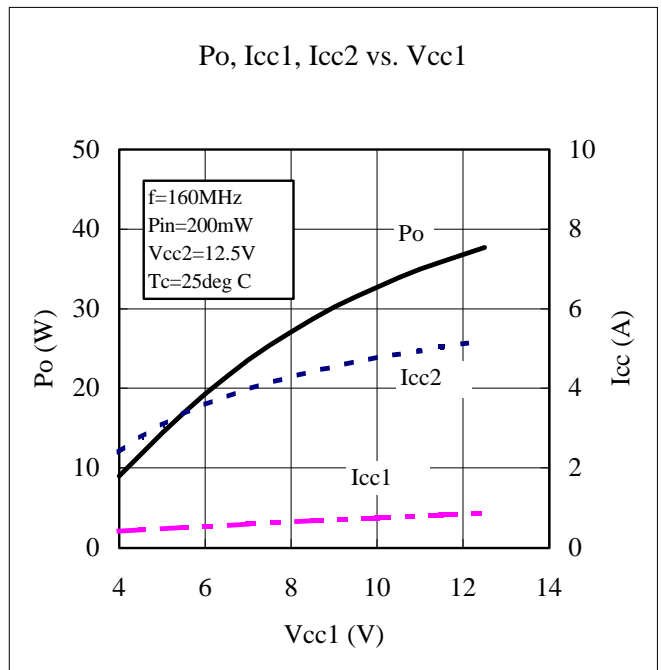
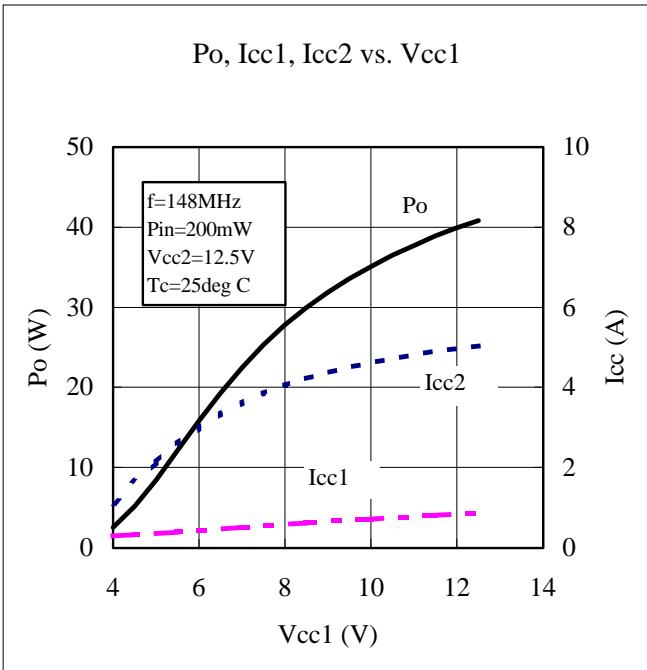
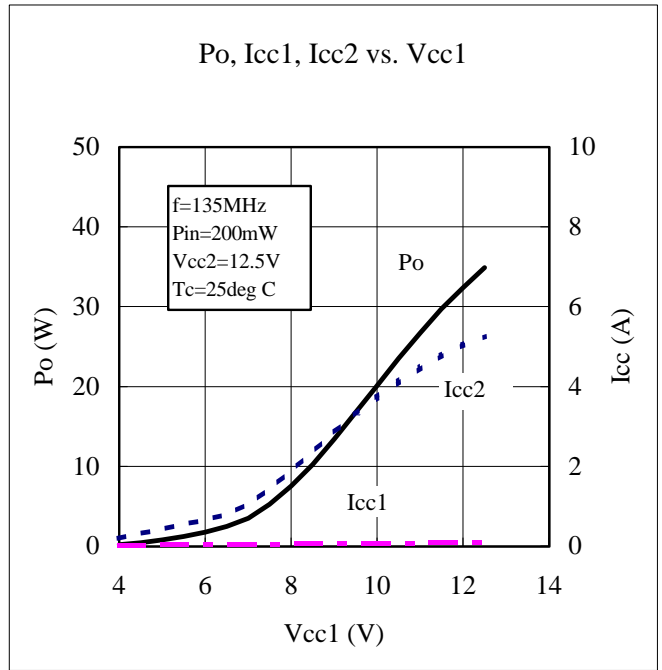
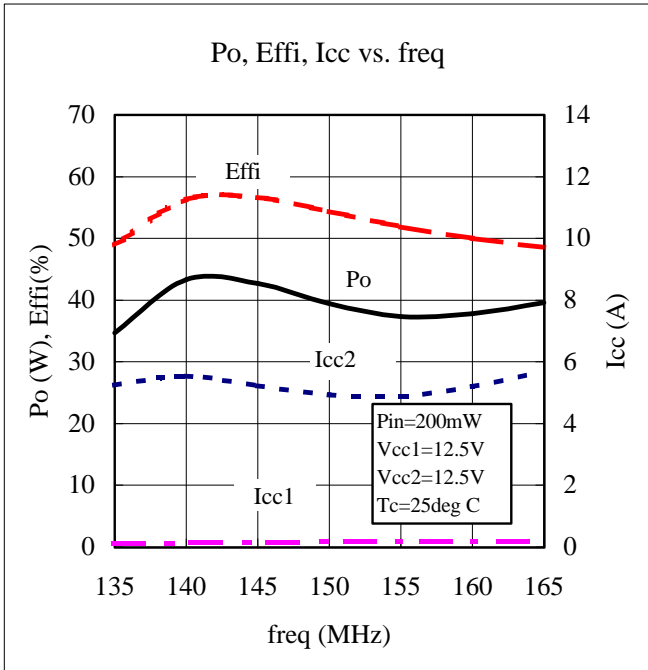

Po, Icc1, Icc2 vs. Pin

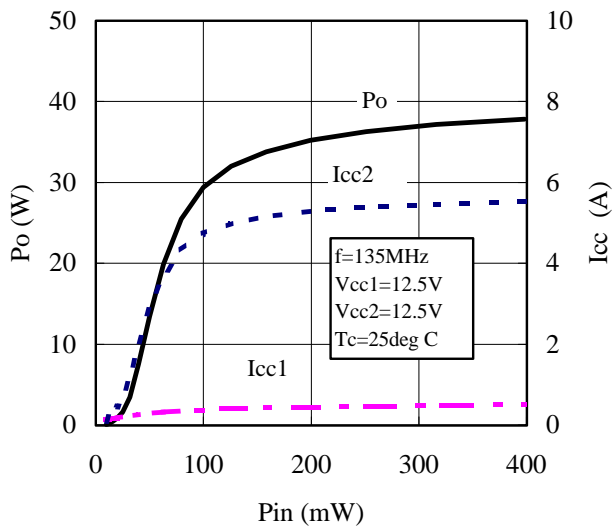

Po, Icc1, Icc2 vs. Pin

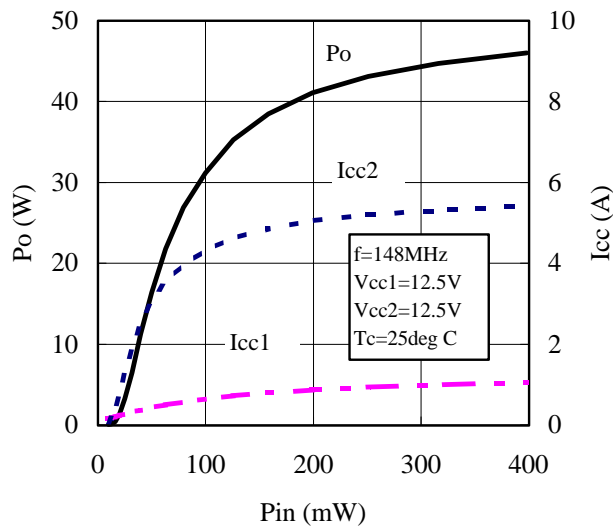

Po, Icc1, Icc2 vs. Pin

