

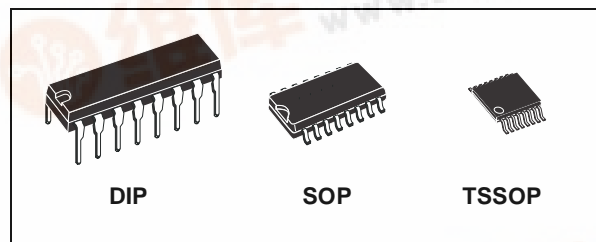

# M74HC139

## DUAL 2 TO 4 DECODER/DEMULTIPLEXER

- HIGH SPEED:  
 $t_{PD} = 13\text{ns}$  (TYP.) at  $V_{CC} = 6\text{V}$
- LOW POWER DISSIPATION:  
 $I_{CC} = 4\mu\text{A}$  (MAX.) at  $T_A = 25^\circ\text{C}$
- HIGH NOISE IMMUNITY:  
 $V_{NIH} = V_{NIL} = 28\% V_{CC}$  (MIN.)
- SYMMETRICAL OUTPUT IMPEDANCE:  
 $|I_{OH}| = I_{OL} = 4\text{mA}$  (MIN)
- BALANCED PROPAGATION DELAYS:  
 $t_{PLH} \cong t_{PHL}$
- WIDE OPERATING VOLTAGE RANGE:  
 $V_{CC}$  (OPR) = 2V to 6V
- PIN AND FUNCTION COMPATIBLE WITH  
 74 SERIES 139



### ORDER CODES

PACKAGE	TUBE	T & R
DIP	M74HC139B1R	
SOP	M74HC139M1R	M74HC139RM13TR
TSSOP		M74HC139TTR

### DESCRIPTION

The M74HC139 is an high speed CMOS QUAD 2-INPUT NAND GATE fabricated with silicon gate C<sup>2</sup>MOS technology.

The active low enable input can be used for gating or as a data input for demultiplexing applications.

While the enable input is held high, all four outputs are high independently of the other inputs. All inputs are equipped with protection circuits against static discharge and transient excess voltage.

### PIN CONNECTION AND IEC LOGIC SYMBOLS

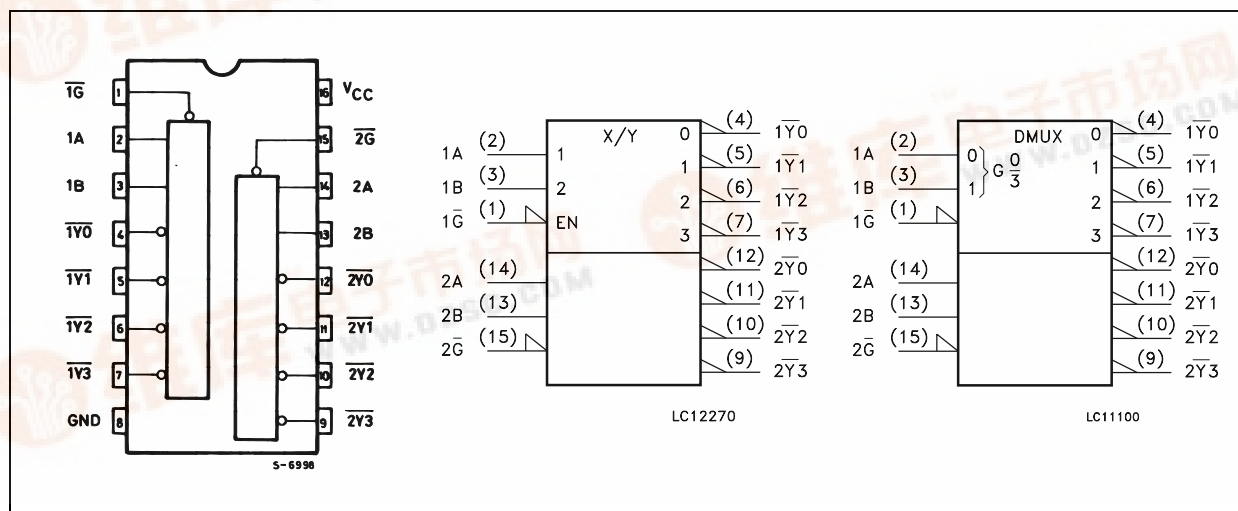

# M74HC139

## INPUT AND OUTPUT EQUIVALENT CIRCUIT

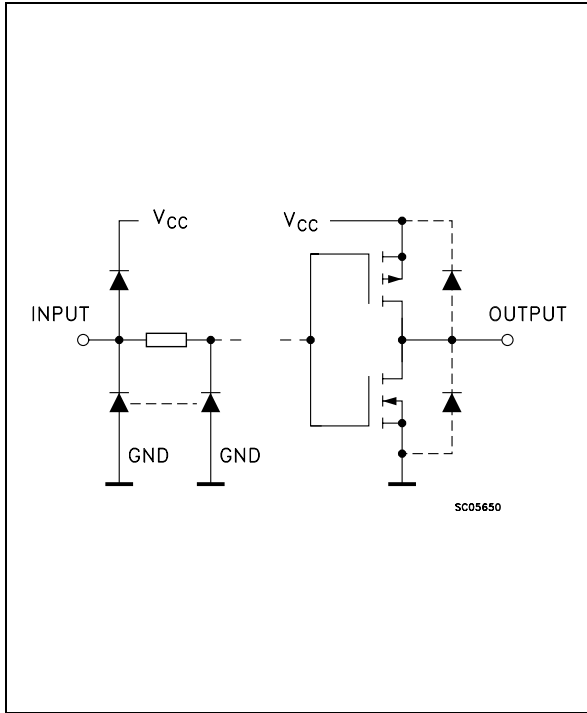

## PIN DESCRIPTION

PIN No	SYMBOL	NAME AND FUNCTION
1, 15	1G, 2G	Enable Inputs
2, 3	1A, 1B	Address Inputs
4, 5, 6, 7	1Y <sub>0</sub> TO 1Y <sub>3</sub>	Outputs
12, 11, 10, 9	2Y <sub>0</sub> TO 2Y <sub>3</sub>	Outputs
14, 13	2A, 2B	Address Inputs
8	GND	Ground (0V)
16	V <sub>CC</sub>	Positive Supply Voltage

## TRUTH TABLE

INPUTS			OUTPUTS				SELECTED OUTPUT
ENABLE	SELECT		$\bar{Y}_0$	$\bar{Y}_1$	$\bar{Y}_2$	$\bar{Y}_3$	
$\bar{G}$	B	A					
H	X	X	H	H	H	H	NONE
L	L	L	L	H	H	H	Y <sub>0</sub>
L	L	H	H	L	H	H	Y <sub>1</sub>
L	H	L	H	H	L	H	Y <sub>2</sub>
L	H	H	H	H	H	L	Y <sub>3</sub>

## LOGIC DIAGRAM

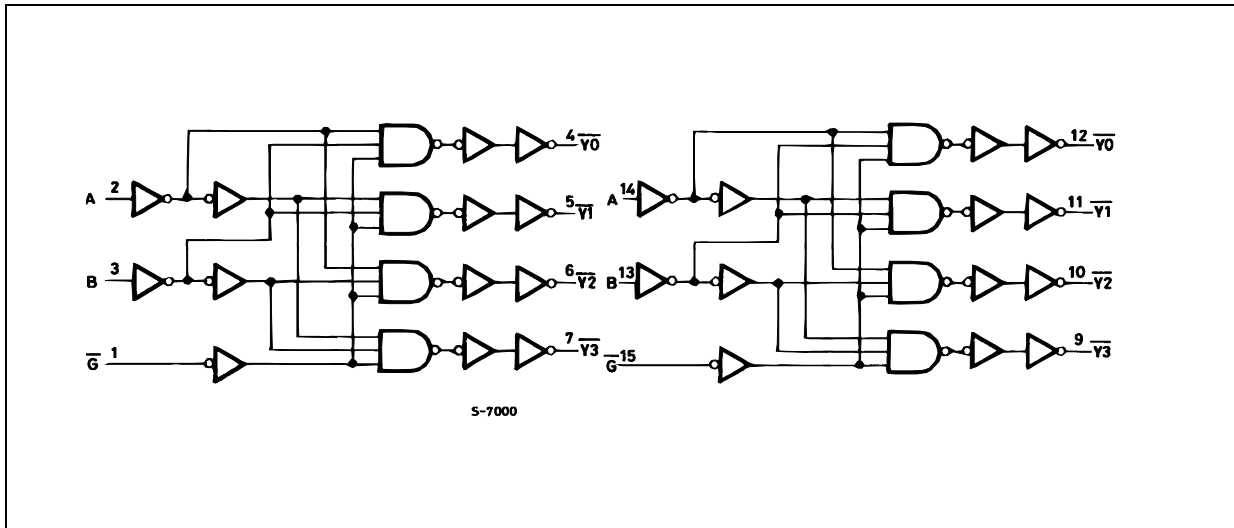

This logic diagram has not been used to estimate propagation delays

**ABSOLUTE MAXIMUM RATINGS**

Symbol	Parameter	Value	Unit
$V_{CC}$	Supply Voltage	-0.5 to +7	V
$V_I$	DC Input Voltage	-0.5 to $V_{CC} + 0.5$	V
$V_O$	DC Output Voltage	-0.5 to $V_{CC} + 0.5$	V
$I_{IK}$	DC Input Diode Current	$\pm 20$	mA
$I_{OK}$	DC Output Diode Current	$\pm 20$	mA
$I_O$	DC Output Current	$\pm 25$	mA
$I_{CC}$ or $I_{GND}$	DC $V_{CC}$ or Ground Current	$\pm 50$	mA
$P_D$	Power Dissipation	500(*)	mW
$T_{stg}$	Storage Temperature	-65 to +150	°C
$T_L$	Lead Temperature (10 sec)	300	°C

Absolute Maximum Ratings are those values beyond which damage to the device may occur. Functional operation under these conditions is not implied

(\*) 500mW at 65 °C; derate to 300mW by 10mW/°C from 65°C to 85°C

**RECOMMENDED OPERATING CONDITIONS**

Symbol	Parameter	Value	Unit	
$V_{CC}$	Supply Voltage	2 to 6	V	
$V_I$	Input Voltage	0 to $V_{CC}$	V	
$V_O$	Output Voltage	0 to $V_{CC}$	V	
$T_{op}$	Operating Temperature	-55 to 125	°C	
$t_r, t_f$	Input Rise and Fall Time	$V_{CC} = 2.0V$	0 to 1000	ns
		$V_{CC} = 4.5V$	0 to 500	ns
		$V_{CC} = 6.0V$	0 to 400	ns

## M74HC139

### DC SPECIFICATIONS

Symbol	Parameter	Test Condition		Value						Unit	
		V <sub>CC</sub> (V)		T <sub>A</sub> = 25°C			-40 to 85°C		-55 to 125°C		
				Min.	Typ.	Max.	Min.	Max.	Min.		Max.
V <sub>IH</sub>	High Level Input Voltage	2.0		1.5			1.5		1.5		V
		4.5		3.15			3.15		3.15		
		6.0		4.2			4.2		4.2		
V <sub>IL</sub>	Low Level Input Voltage	2.0				0.5		0.5		0.5	V
		4.5				1.35		1.35		1.35	
		6.0				1.8		1.8		1.8	
V <sub>OH</sub>	High Level Output Voltage	2.0	I <sub>O</sub> =-20 μA	1.9	2.0		1.9		1.9		V
		4.5	I <sub>O</sub> =-20 μA	4.4	4.5		4.4		4.4		
		6.0	I <sub>O</sub> =-20 μA	5.9	6.0		5.9		5.9		
		4.5	I <sub>O</sub> =-4.0 mA	4.18	4.31		4.13		4.10		
		6.0	I <sub>O</sub> =-5.2 mA	5.68	5.8		5.63		5.60		
V <sub>OL</sub>	Low Level Output Voltage	2.0	I <sub>O</sub> =20 μA		0.0	0.1		0.1		0.1	V
		4.5	I <sub>O</sub> =20 μA		0.0	0.1		0.1		0.1	
		6.0	I <sub>O</sub> =20 μA		0.0	0.1		0.1		0.1	
		4.5	I <sub>O</sub> =4.0 mA		0.17	0.26		0.33		0.40	
		6.0	I <sub>O</sub> =5.2 mA		0.18	0.26		0.33		0.40	
I <sub>I</sub>	Input Leakage Current	6.0	V <sub>I</sub> = V <sub>CC</sub> or GND			± 0.1		± 1		± 1	μA
I <sub>CC</sub>	Quiescent Supply Current	6.0	V <sub>I</sub> = V <sub>CC</sub> or GND			4		40		80	μA

### AC ELECTRICAL CHARACTERISTICS (C<sub>L</sub> = 50 pF, Input t<sub>r</sub> = t<sub>f</sub> = 6ns)

Symbol	Parameter	Test Condition		Value						Unit	
		V <sub>CC</sub> (V)		T <sub>A</sub> = 25°C			-40 to 85°C		-55 to 125°C		
				Min.	Typ.	Max.	Min.	Max.	Min.		Max.
t <sub>TLH</sub> t <sub>THL</sub>	Output Transition Time	2.0			30	75		95		110	ns
		4.5			8	15		19		22	
		6.0			7	13		16		19	
t <sub>PLH</sub> t <sub>PHL</sub>	Propagation Delay Time (A, B -Y)	2.0			45	130		165		195	ns
		4.5			15	26		33		39	
		6.0			13	22		28		33	
t <sub>PLH</sub> t <sub>PHL</sub>	Propagation Delay Time (G -Y)	2.0			39	110		140		165	ns
		4.5			13	22		28		33	
		6.0			11	19		24		28	

**CAPACITIVE CHARACTERISTICS**

Symbol	Parameter	Test Condition		Value						Unit	
		V <sub>CC</sub> (V)		T <sub>A</sub> = 25°C			-40 to 85°C		-55 to 125°C		
				Min.	Typ.	Max.	Min.	Max.	Min.		Max.
C <sub>IN</sub>	Input Capacitance	5.0			5	10		10		10	pF
C <sub>PD</sub>	Power Dissipation Capacitance (note 1)	5.0			46						pF

1) C<sub>PD</sub> is defined as the value of the IC's internal equivalent capacitance which is calculated from the operating current consumption without load. (Refer to Test Circuit). Average operating current can be obtained by the following equation.  $I_{CC(opr)} = C_{PD} \times V_{CC} \times f_{IN} + I_{CC}/2$  (per circuit)

**TEST CIRCUIT**

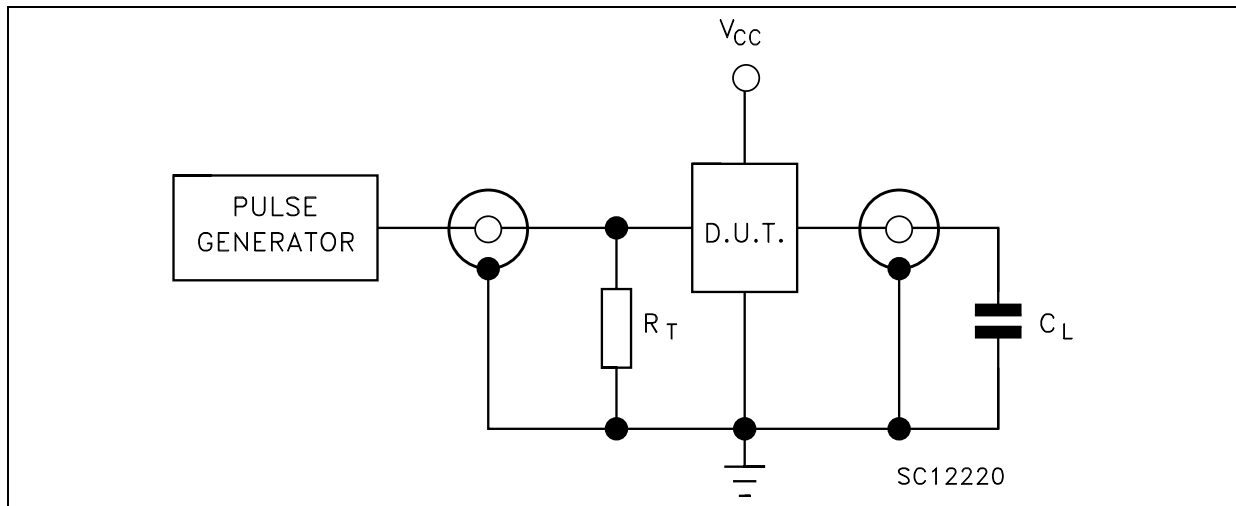

C<sub>L</sub> = 50pF or equivalent (includes jig and probe capacitance)  
 R<sub>T</sub> = Z<sub>OUT</sub> of pulse generator (typically 50Ω)

**WAVEFORM : PROPAGATION DELAY TIMES (f=1MHz; 50% duty cycle)**

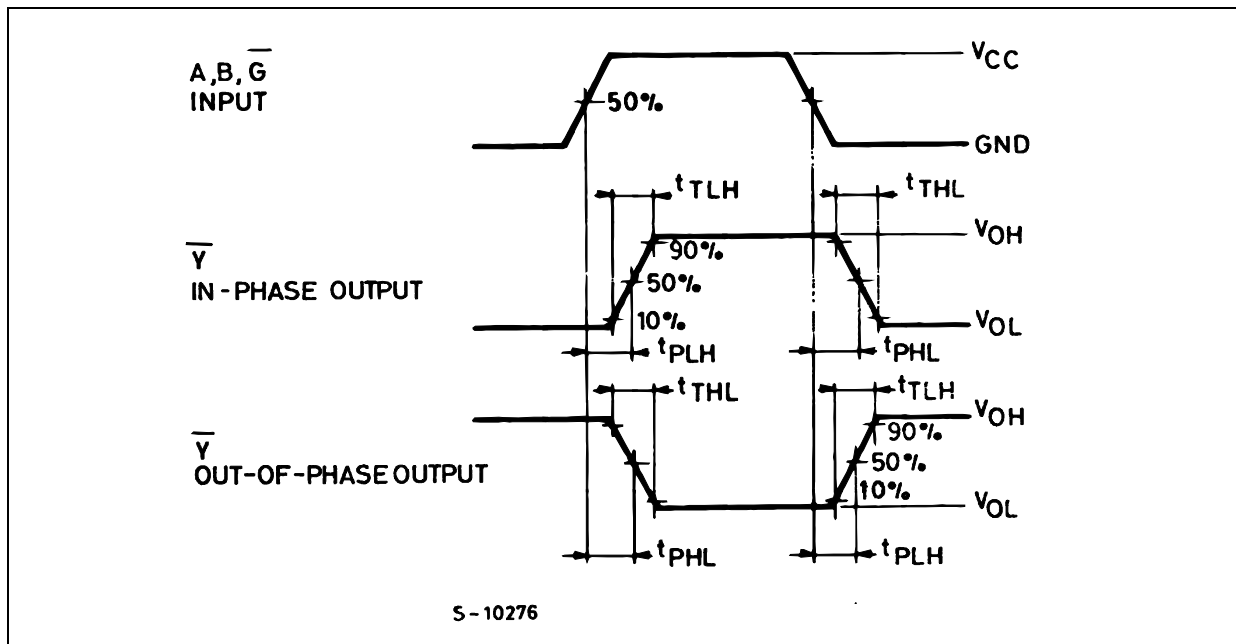

S-10276

**Plastic DIP-16 (0.25) MECHANICAL DATA**

DIM.	mm.			inch		
	MIN.	TYP.	MAX.	MIN.	TYP.	MAX.
a1	0.51			0.020		
B	0.77		1.65	0.030		0.065
b		0.5			0.020	
b1		0.25			0.010	
D			20			0.787
E		8.5			0.335	
e		2.54			0.100	
e3		17.78			0.700	
F			7.1			0.280
I			5.1			0.201
L		3.3			0.130	
Z			1.27			0.050

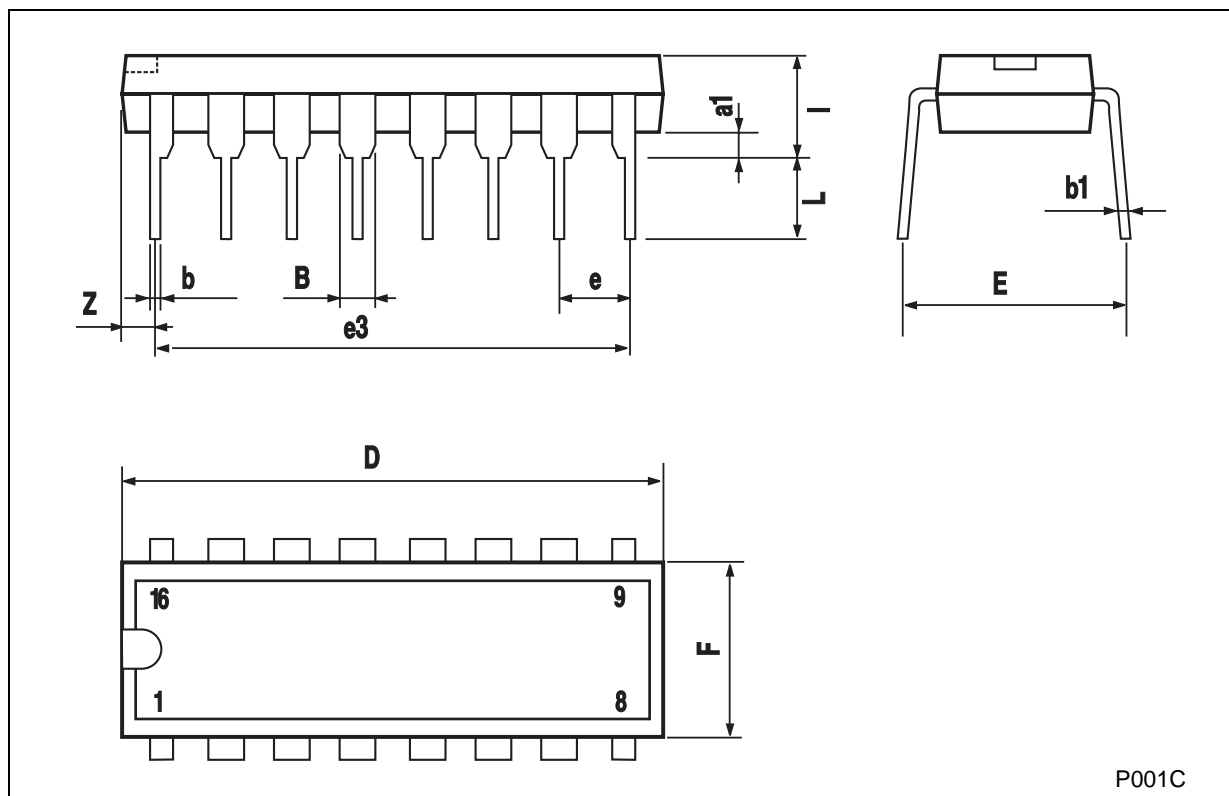

P001C

## SO-16 MECHANICAL DATA

DIM.	mm.			inch		
	MIN.	TYP	MAX.	MIN.	TYP.	MAX.
A			1.75			0.068
a1	0.1		0.2	0.003		0.007
a2			1.65			0.064
b	0.35		0.46	0.013		0.018
b1	0.19		0.25	0.007		0.010
C		0.5			0.019	
c1	45° (typ.)					
D	9.8		10	0.385		0.393
E	5.8		6.2	0.228		0.244
e		1.27			0.050	
e3		8.89			0.350	
F	3.8		4.0	0.149		0.157
G	4.6		5.3	0.181		0.208
L	0.5		1.27	0.019		0.050
M			0.62			0.024
S	8° (max.)					

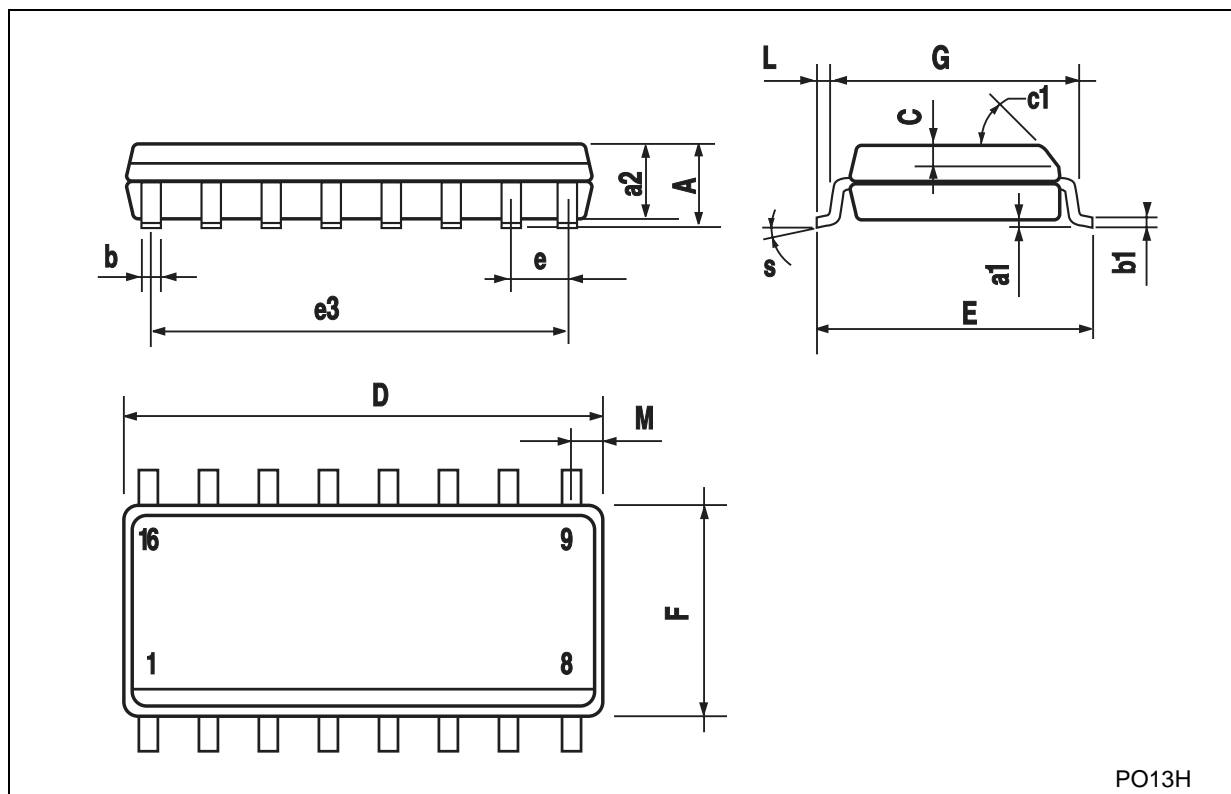

PO13H

## TSSOP16 MECHANICAL DATA

DIM.	mm.			inch		
	MIN.	TYP	MAX.	MIN.	TYP.	MAX.
A			1.2			0.047
A1	0.05		0.15	0.002	0.004	0.006
A2	0.8	1	1.05	0.031	0.039	0.041
b	0.19		0.30	0.007		0.012
c	0.09		0.20	0.004		0.0089
D	4.9	5	5.1	0.193	0.197	0.201
E	6.2	6.4	6.6	0.244	0.252	0.260
E1	4.3	4.4	4.48	0.169	0.173	0.176
e		0.65 BSC			0.0256 BSC	
K	0°		8°	0°		8°
L	0.45	0.60	0.75	0.018	0.024	0.030

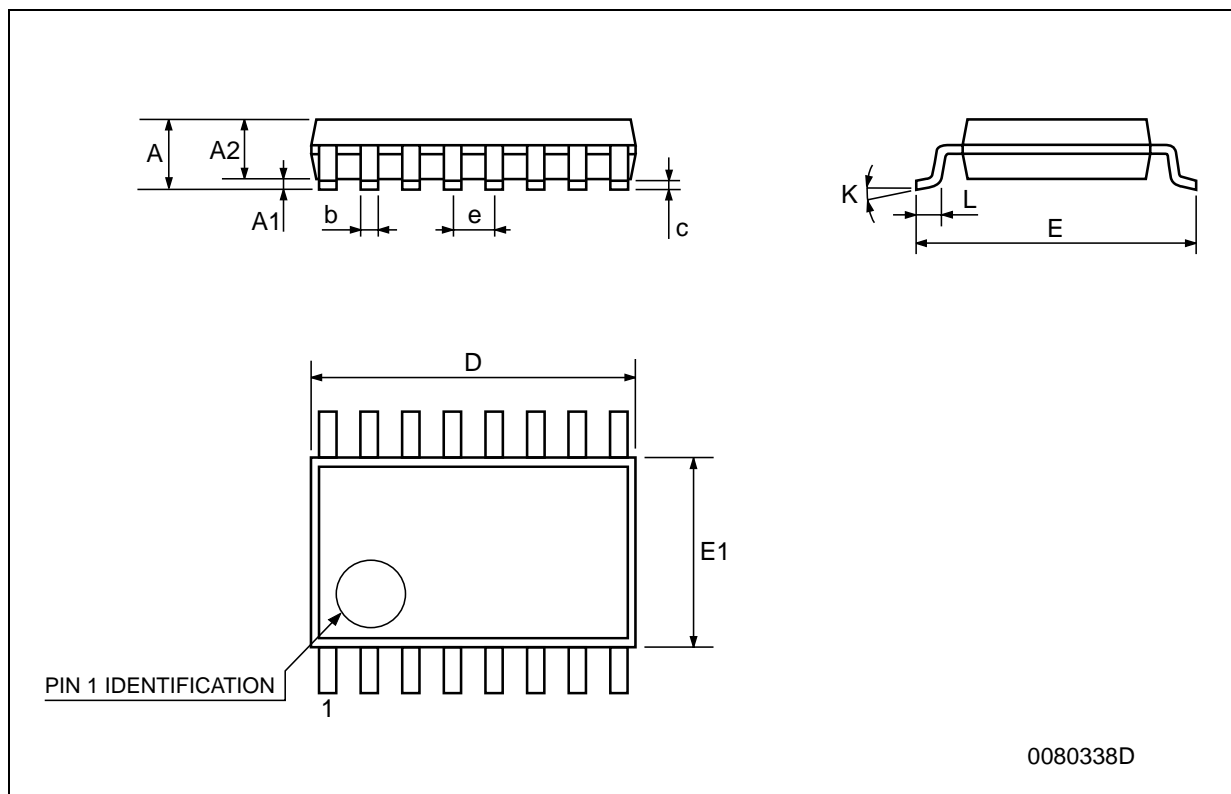



Information furnished is believed to be accurate and reliable. However, STMicroelectronics assumes no responsibility for the consequences of use of such information nor for any infringement of patents or other rights of third parties which may result from its use. No license is granted by implication or otherwise under any patent or patent rights of STMicroelectronics. Specifications mentioned in this publication are subject to change without notice. This publication supersedes and replaces all information previously supplied. STMicroelectronics products are not authorized for use as critical components in life support devices or systems without express written approval of STMicroelectronics.

© The ST logo is a registered trademark of STMicroelectronics

© 2001 STMicroelectronics - Printed in Italy - All Rights Reserved  
STMicroelectronics GROUP OF COMPANIES

Australia - Brazil - China - Finland - France - Germany - Hong Kong - India - Italy - Japan - Malaysia - Malta - Morocco  
Singapore - Spain - Sweden - Switzerland - United Kingdom

© <http://www.st.com>

