



Am79C960

PCnet™-ISA Single-Chip Ethernet Controller

DISTINCTIVE CHARACTERISTICS

- Single-chip Ethernet controller for the Industry Standard Architecture (ISA) and Extended Industry Standard Architecture (EISA) buses
- Supports IEEE 802.3/ANSI 8802-3 and Ethernet standards
- Direct interface to the ISA or EISA bus
- Software compatible with AMD's Am7990 LANCE register and descriptor architecture
- Low power, CMOS design with sleep mode allows reduced power consumption for critical battery powered applications
- Individual 136-byte transmit and 128-byte receive FIFOs provide packet buffering for increased system latency, and support the following features:
 - Automatic retransmission with no FIFO reload
 - Automatic receive stripping and transmit padding (individually programmable)
 - Automatic runt packet rejection
 - Automatic deletion of received collision frames
- Dynamic transmit FCS generation programmable on a frame-by-frame basis
- Single +5 V power supply
- Internal/external loopback capabilities
- Supports optional Boot PROM for diskless node applications
- Provides integrated Attachment Unit Interface (AUI) and 10BASE-T transceiver with 3 modes of port selection:
 - Automatic selection of AUI or 10BASE-T
 - Software selection of AUI or 10BASE-T
 - Jumper selection of AUI or 10BASE-T
- Automatic Twisted Pair receive polarity detection and automatic correction of the receive polarity
- Supports bus-master and shared-memory architectures to fit in any PC application
- Supports edge and level-sensitive interrupts
- DMA Buffer Management Unit for reduced CPU intervention
- Integral DMA controller allows higher throughput by by-passing the platform DMA
- JTAG Boundary Scan (IEEE 1149.1) test access port interface for board level production test
- Integrated Manchester Encoder/Decoder
- Supports the following types of network interfaces:
 - AUI to external 10BASE2, 10BASE5, 10BASE-T or 10BASE-F MAU
 - Internal 10BASE-T transceiver with Smart Squelch to Twisted Pair medium
- Supports LANCE General Purpose Serial Interface (GPSI)
- 120-pin PQFP package

GENERAL DESCRIPTION

The PCnet-ISA controller, a single-chip Ethernet controller, is a highly integrated system solution for the PC-AT Industry Standard Architecture (ISA) architecture. It is designed to provide flexibility and compatibility with any existing PC application. This highly integrated 120-pin VLSI device is specifically designed to reduce parts count and cost, and addresses applications where higher system throughput is desired. The PCnet-ISA controller is fabricated with AMD's advanced low-power CMOS process to provide low stand by current for power sensitive applications.

The PCnet-ISA controller is a DMA-based device with a dual architecture that can be configured in two different

operating modes to suit a particular PC application. In the Bus Master Mode all transfers are performed using the integrated DMA controller. This configuration enhances system performance by allowing the PCnet-ISA controller to bypass the platform DMA controller and directly address the full 24-bit memory space. The implementation of Bus Master Mode allows minimum parts count for the majority of PC applications. The PCnet-ISA controller can be configured to perform Shared Memory operations for compatibility with low-end machines, such as PC/XTs that do not support Bus Master and high-end machines that require local packet buffering for increased system latency.

The PCnet-ISA controller is designed to directly interface with the ISA or EISA system bus. It contains an ISA bus interface unit, DMA Buffer Management Unit, IEEE 802.3 Media Access Control function, individual 136-byte transmit and 128-byte receive FIFOs, IEEE 802.3 defined Attachment Unit Interface (AUI), and a Twisted Pair Transceiver Media Attachment Unit. The PCnet-ISA controller is also register compatible with the LANCE (Am7990) Ethernet controller. The DMA Buffer Management Unit supports the LANCE descriptor software model. External remote boot and Ethernet physical address PROMs are also supported.

This advanced Ethernet controller has the built-in capability of automatically selecting either the AUI port or the Twisted Pair transceiver. Only one interface is active at

any one time. The individual 136-byte transmit and 128-byte receive FIFOs optimize system overhead, providing sufficient latency during packet transmission and reception, and minimizing intervention during normal network error recovery. The integrated Manchester encoder/decoder eliminates the need for an external Serial Interface Adapter (SIA) in the node system. If support for an external encoding/decoding scheme is desired, the embedded General Purpose Serial Interface (GPSI) allows direct access to/from the MAC. In addition, the device provides programmable on-chip LED drivers for transmit, receive, collision, receive polarity, link integrity, or jabber status. The PCnet-ISA controller also provides an External Address Detection Interface™ (EADI™) to allow external hardware address filtering in internetworking applications.

RELATED PRODUCTS

Part No.	Description
Am79C98	Twisted Pair Ethernet Transceiver (TPEX)
Am79C100	Twisted Pair Ethernet Transceiver Plus (TPEX+)
Am7996	IEEE 802.3/Ethernet/Cheapernet Transceiver
Am79C981	Integrated Multiport Repeater Plus™ (IMR+™)
Am79C987	Hardware Implemented Management Information Base™ (HIMIB™)
Am79C940	Media Access Controller for Ethernet (MACE™)
Am7990	Local Area Network Controller for Ethernet (LANCE)
Am79C90	CMOS Local Area Network Controller for Ethernet (C-LANCE)
Am79C900	Integrated Local Area Communications Controller™ (ILACC™)
Am79C961	PCnet-ISA+ Single-Chip Ethernet Controller for ISA (with Microsoft® Plug n' Play® Support)
Am79C965	PCnet-32 Single-Chip 32-Bit Ethernet Controller
Am79C970	PCnet-PCI Single-Chip Ethernet Controller (for PCI bus)
Am79C974	PCnet-SCSI Combination Ethernet and SCSI Controller for PCI Systems

ORDERING INFORMATION

Standard Products

AMD standard products are available in several packages and operating ranges. The order number (Valid Combination) is formed by a combination of:

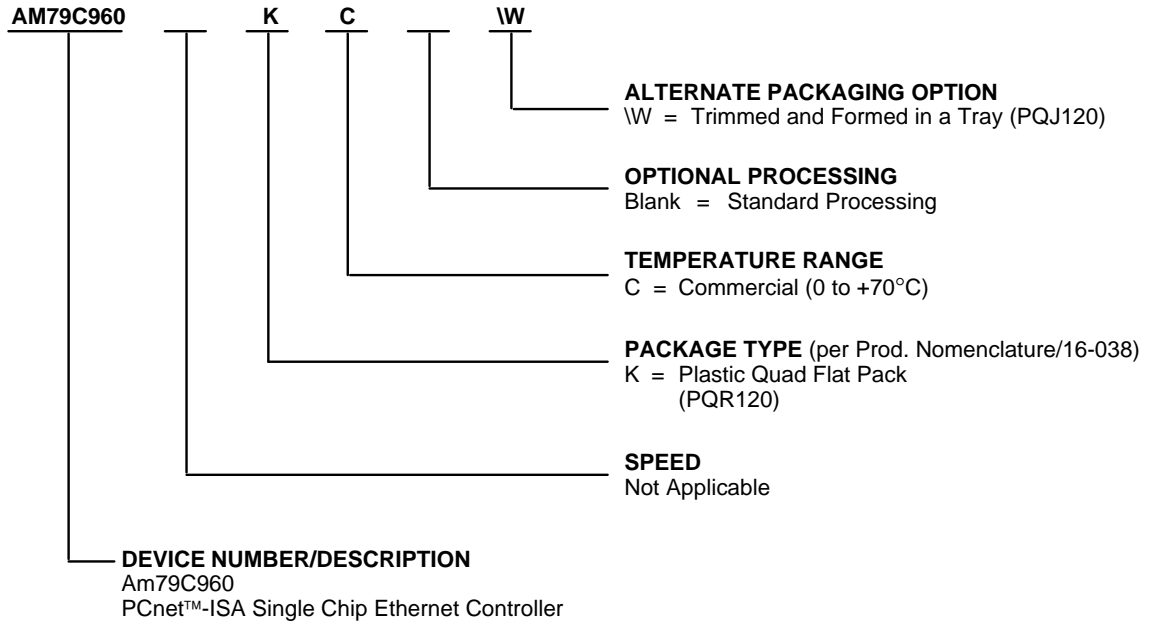

Valid Combinations	
AM79C960	KC, KC\W

Valid Combinations

The Valid Combinations table lists configurations planned to be supported in volume for this device. Consult the local AMD sales office to confirm availability of specific valid combinations and to check on newly released combinations.

TABLE OF CONTENTS	
DISTINCTIVE CHARACTERISTICS	1-343
GENERAL DESCRIPTION	1-343
RELATED PRODUCTS	1-344
ORDERING INFORMATION	1-345
BLOCK DIAGRAM: BUS MASTER MODE	1-352
CONNECTION DIAGRAM: BUS MASTER	1-353
PIN DESIGNATIONS: BUS MASTER	
LISTED BY PIN NUMBER	1-354
LISTED BY PIN NAME	1-355
LISTED BY GROUP	1-356
PIN DESCRIPTION: BUS MASTER MODE	1-358
ISA INTERFACE	1-358
BOARD INTERFACE	1-359
BLOCK DIAGRAM: SHARED MEMORY	1-361
CONNECTION DIAGRAM: SHARED MEMORY	1-362
PIN DESIGNATIONS: SHARED MEMORY	
LISTED BY PIN NUMBER	1-363
LISTED BY PIN NAME	1-364
LISTED BY GROUP	1-365
PIN DESCRIPTION: SHARED MEMORY MODE	1-367
ISA INTERFACE	1-367
BOARD INTERFACE	1-368
PIN DESCRIPTION: NETWORK INTERFACES (mode independent)	1-370
AUI INTERFACE	1-370
TWISTED PAIR INTERFACE	1-370
IEEE 1149.1 TEST ACCESS PORT INTERFACE	1-370
PIN DESCRIPTION: POWER SUPPLIES (mode independent)	1-371
FUNCTIONAL DESCRIPTION	1-372
BUS MASTER MODE	1-372
SHARED MEMORY MODE	1-373
NETWORK INTERFACE	1-373

DETAILED FUNCTIONS	1-374
BUS INTERFACE UNIT (BIU)	1-374
DMA Transfers	1-374
1. Initialization Block DMA Transfers	1-374
2. Descriptor DMA Transfers	1-374
3. Burst-Cycle DMA Transfers	1-374
BUFFER MANAGEMENT UNIT (BMU)	1-374
Initialization	1-374
Reinitialization	1-374
Buffer Management	1-375
Descriptor Rings	1-375
Descriptor Ring Access Mechanism	1-375
Polling	1-376
Transmit Descriptor Table Entry (TDTE)	1-377
Receive Descriptor Table Entry (RDTE)	1-378
MEDIA ACCESS CONTROL	1-379
Transmit and Receive Message Data Encapsulation	1-379
Media Access Management	1-380
MANCHESTER ENCODER/DECODER (MENDEC)	1-382
External Crystal Characteristics	1-382
External Clock Drive Characteristics	1-382
MENDEC Transmit Path	1-382
Transmitter Timing and Operation	1-383
Receive Path	1-383
Input Signal Conditioning	1-383
Clock Acquisition	1-383
PLL Tracking	1-384
Carrier Tracking and End of Message	1-384
Data Decoding	1-384
Jitter Tolerance Definition	1-384
Attachment Unit Interface (AUI)	1-384
Differential Input Terminations	1-384
Collision Detection	1-384
TWISTED PAIR TRANSCEIVER (T-MAU)	1-385
Twisted Pair Transmit Function	1-385
Twisted Pair Receive Function	1-385
Link Test Function	1-385
Polarity Detection and Reversal	1-385
Twisted Pair Interface Status	1-386
Collision Detect Function	1-386
Signal Quality Error (SQE) Test (Heartbeat) Function	1-386
Jabber Function	1-386
Power Down	1-386
EADI™ (External Address Detection Interface™)	1-387

GENERAL PURPOSE SERIAL INTERFACE (GPSI)	1-388
IEEE 1149.1 TEST ACCESS PORT INTERFACE	1-389
Boundary Scan Circuit	1-389
TAP FSM	1-389
Supported Instructions	1-389
Instruction Register and Decoding Logic	1-389
Boundary Scan Register (BSR)	1-389
Other Data Register	1-389
POWER SAVINGS MODES	1-390
ACCESS OPERATIONS (SOFTWARE)	
I/O Resources	1-390
I/O Register Access	1-390
Address PROM Access	1-390
Boot PROM Access	1-390
Static RAM Access	1-390
BUS CYCLES (HARDWARE)	1-390
Bus Master Mode	1-391
Refresh Cycles	1-392
Address PROM Cycles	1-392
Ethernet Controller Register Cycles	1-392
RESET Cycles	1-392
ISA Configuration Register Cycles	1-392
Boot PROM Cycles	1-392
Current Master Operation	1-393
Master Mode Memory Read Cycle	1-393
Master Mode Memory Write Cycle	1-393
Shared Memory Mode	1-394
Address PROM Cycles	1-394
Ethernet Controller Register Cycles	1-394
RESET Cycles	1-394
ISA Configuration Register Cycles	1-394
Boot PROM Cycles	1-394
Static RAM Cycles	1-395
TRANSMIT OPERATION	1-396
Transmit Function Programming	1-396
Automatic Pad Generation	1-396
Transmit FCS Generation	1-397
Transmit Exception Conditions	1-397
Loss of Carrier	1-397
RECEIVE OPERATION	1-398
Receive Function Programming	1-398
Automatic Pad Stripping	1-398
Receive FCS Checking	1-399
Receive Exception Conditions	1-399

LOOPBACK OPERATION	1-399
LEDs	1-399
PCnet-ISA CONTROLLER REGISTERS	1-401
REGISTER ACCESS	1-401
CONTROL AND STATUS REGISTERS	1-401
CSR0: PCnet-ISA Controller Status Register	1-401
CSR1: IADR[15:0]	1-403
CSR2: IADR[23:16]	1-403
CSR3: Interrupt Masks and Deferral Control	1-403
CSR4: Test and Features Control	1-404
CSR6: RCV/XMT Descriptor Table Length	1-405
CSR8: Logical Address Filter, LADRF[15:0]	1-405
CSR9: Logical Address Filter, LADRF[31:16]	1-405
CSR10: Logical Address Filter, LADRF[47:32]	1-405
CSR11: Logical Address Filter, LADRF[63:48]	1-405
CSR12: Physical Address Register, PADR[15:0]	1-406
CSR13: Physical Address Register, PADR[31:16]	1-406
CSR14: Physical Address Register, PADR[47:32]	1-406
CSR15: Mode Register	1-406
CSR16: Initialization Block Address	1-408
CSR17: Initialization Block Address	1-408
CSR18–19: Current Receive Buffer Address	1-408
CSR20–21: Current Transmit Buffer Address	1-408
CSR22–23: Next Receive Buffer Address	1-408
CSR24–25: Base Address of Receive Ring	1-409
CSR26–27: Next Receive Descriptor Address	1-409
CSR28–29: Current Receive Descriptor Address	1-409
CSR30–31: Base Address of Transmit Ring	1-409
CSR32–33: Next Transmit Descriptor Address	1-409
CSR34–35: Current Transmit Descriptor Address	1-409
CSR36–37: Next Next Receive Descriptor Address	1-409
CSR38–39: Next Next Transmit Descriptor Address	1-409
CSR40–41: Current Receive Status and Byte Count	1-409
CSR42–43: Current Transmit Status and Byte Count	1-410
CSR44–45: Next Receive Status and Byte Count	1-410
CSR46: Poll Time Counter	1-410
CSR47: Polling Interval	1-410
CSR48–49: Temporary Storage	1-411
CSR50–51: Temporary Storage	1-411
CSR52–53: Temporary Storage	1-411
CSR54–55: Temporary Storage	1-411
CSR56–57: Temporary Storage	1-411
CSR58–59: Temporary Storage	1-411
CSR60–61: Previous Transmit Descriptor Address	1-411
CSR62–63: Previous Transmit Status and Byte Count	1-411
CSR64–65: Next Transmit Buffer Address	1-411

CSR66–67: Next Transmit Status and Byte Count	1-411
CSR68–69: Transmit Status Temporary Storage	1-412
CSR70–71: Temporary Storage	1-412
CSR72: Receive Ring Counter	1-412
CSR74: Transmit Ring Counter	1-412
CSR76: Receive Ring Length	1-412
CSR78: Transmit Ring Length	1-412
CSR80: Burst and FIFO Threshold Control	1-412
CSR82: Bus Activity Timer	1-413
CSR84–85: DMA Address	1-414
CSR86: Buffer Byte Counter	1-414
CSR88–89: Chip ID.	1-414
CSR92: Ring Length Conversion.	1-414
CSR94: Transmit Time Domain Reflectometry Count	1-414
CSR96–97: Bus Interface Scratch Register 0	1-415
CSR98–99: Bus Interface Scratch Register 1	1-415
CSR104–105: SWAP	1-415
CSR108–109: Buffer Management Scratch	1-415
CSR112: Missed Frame Count	1-415
CSR114: Receive Collision Count	1-415
CSR124: Buffer Management Unit Test	1-415
 ISA BUS CONFIGURATION REGISTERS	 1-416
 INITIALIZATION BLOCK	 1-419
RLEN and TLEN	1-419
RDRA and TDRA	1-419
LADRF	1-419
PADR	1-420
MODE	1-420
 RECEIVE DESCRIPTORS	 1-420
RMD0	1-420
RMD1	1-420
RMD2	1-421
RMD3	1-421
 TRANSMIT DESCRIPTORS	 1-421
TMD0	1-422
TMD1	1-422
TMD2	1-422
TMD3	1-423
 REGISTER SUMMARY	 1-424

SYSTEM APPLICATION	1-427
ISA BUS INTERFACE	1-427
Compatibility Consideration	1-427
Bus Masters	1-427
Shared Memory	1-427
ADDRESS PROM INTERFACE	1-428
BOOT PROM INTERFACE	1-428
STATIC RAM INTERFACE	1-428
AUI INTERFACE	1-428
10BASE-T INTERFACE	1-429
ABSOLUTE MAXIMUM RATINGS	1-430
OPERATING RANGES	1-430
DC CHARACTERISTICS	1-431
SWITCHING CHARACTERISTICS	1-433
BUS MASTER MODE	1-433
SHARED MEMORY MODE	1-436
EADI	1-439
JTAG (IEEE 1149.1) INTERFACE	1-439
GPSI	1-440
AUI	1-441
10BASE-T INTERFACE	1-442
SWITCHING TEST CIRCUITS	1-443
SWITCHING WAVEFORMS	1-445
BUS MASTER MODE	1-445
SHARED MEMORY MODE	1-451
GPSI	1-458
EADI	1-459
JTAG (IEEE 1149.1) INTERFACE	1-459
AUI	1-460
10BASE-T INTERFACE	1-463
APPENDIX A: PCnet-ISA COMPATIBLE MEDIA INTERFACE MODULES	
10BASE-T FILTERS and TRANSFORMERS	1-465
AUI ISOLATION TRANSFORMERS	1-465
MANUFACTURER CONTACT INFORMATION	1-466
APPENDIX B: RECOMMENDATION FOR REDUCING NOISE INJECTION	
DECOUPLING LOW-PASS RC FILTER DESIGN	1-467
APPENDIX C: ALTERNATIVE METHOD FOR INITIALIZATION	1-469
DATA SHEET REVISION SUMMARY	1-470

BLOCK DIAGRAM: BUS MASTER MODE

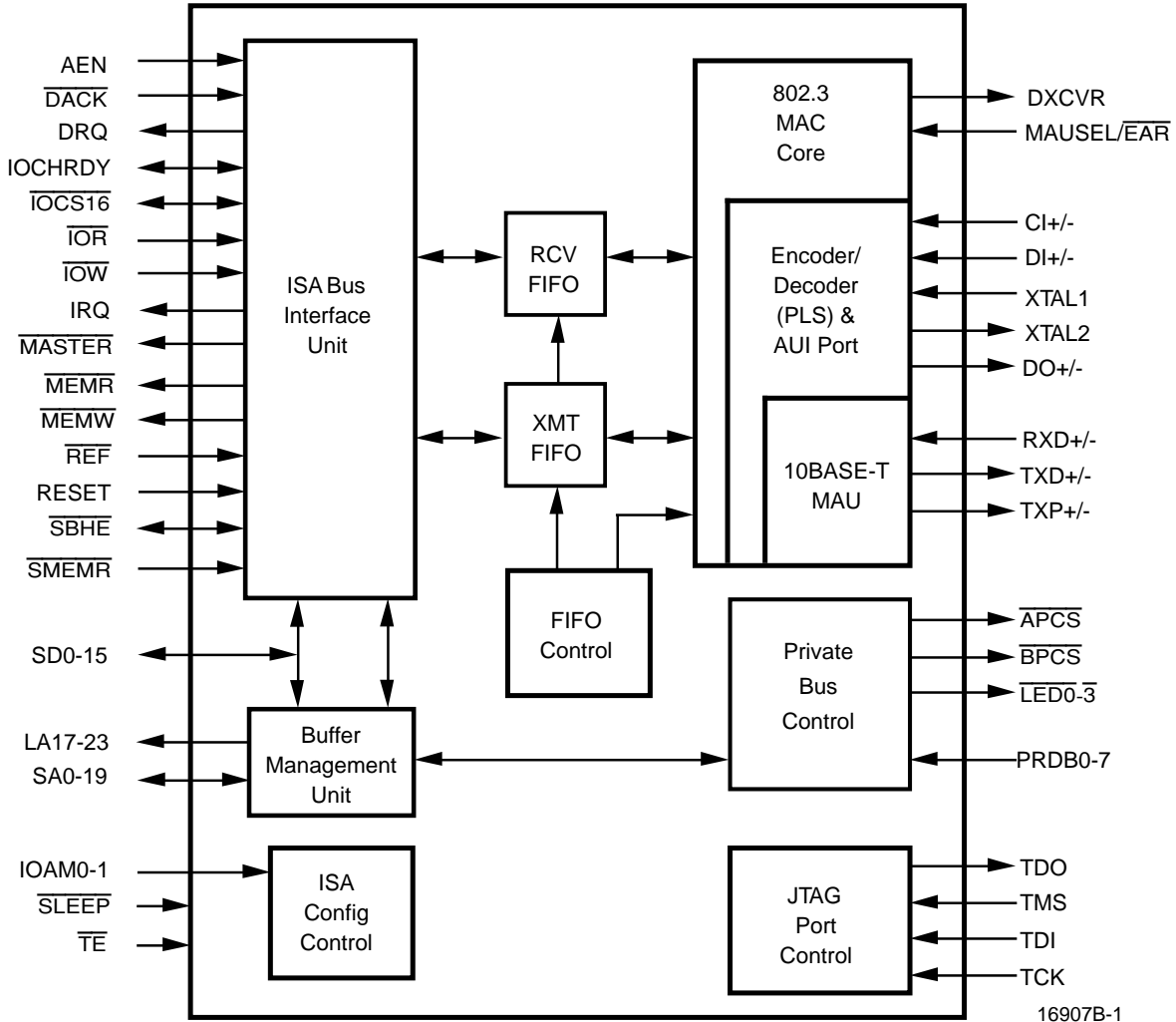

16907B-1

CONNECTION DIAGRAM: BUS MASTER

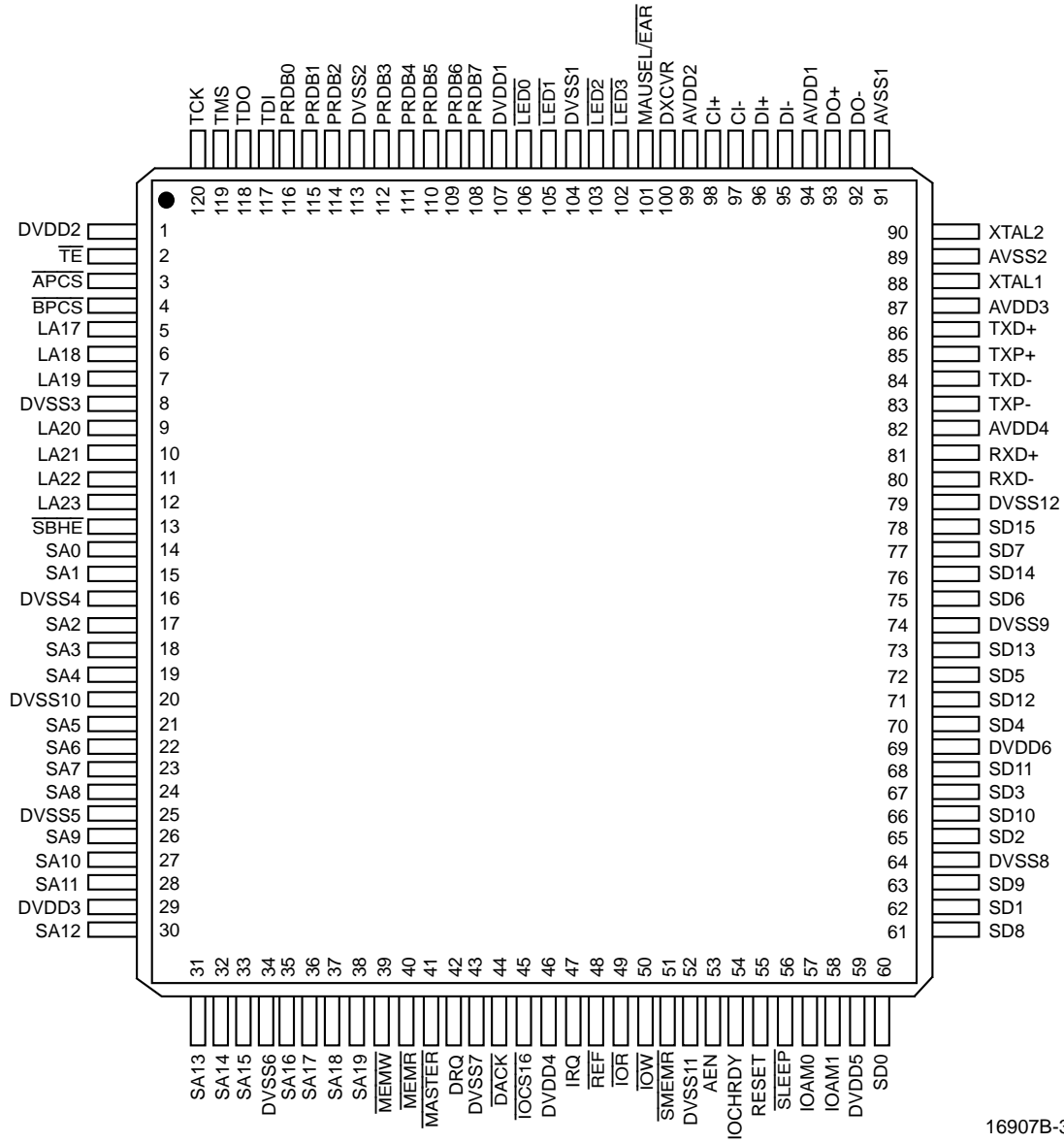

16907B-3

PIN DESIGNATIONS: BUS MASTER

Listed by Pin Number

Pin #	Name	Pin #	Name	Pin #	Name	Pin #	Name
1	DVDD2	31	SA13	61	SD8	91	AVSS1
2	$\overline{\text{TE}}$	32	SA14	62	SD1	92	DO-
3	$\overline{\text{APCS}}$	33	SA15	63	SD9	93	DO+
4	$\overline{\text{BPCS}}$	34	DVSS6	64	DVSS8	94	AVDD1
5	LA17	35	SA16	65	SD2	95	DI-
6	LA18	36	SA17	66	SD10	96	DI+
7	LA19	37	SA18	67	SD3	97	CI-
8	DVSS3	38	SA19	68	SD11	98	CI+
9	LA20	39	$\overline{\text{MEMW}}$	69	DVDD6	99	AVDD2
10	LA21	40	$\overline{\text{MEMR}}$	70	SD4	100	DXCVR
11	LA22	41	$\overline{\text{MASTER}}$	71	SD12	101	MAUSEL/ $\overline{\text{EAR}}$
12	LA23	42	DRQ	72	SD5	102	$\overline{\text{LED3}}$
13	$\overline{\text{SBHE}}$	43	DVSS7	73	SD13	103	$\overline{\text{LED2}}$
14	SA0	44	$\overline{\text{DACK}}$	74	DVSS9	104	DVSS1
15	SA1	45	$\overline{\text{IOCS16}}$	75	SD6	105	$\overline{\text{LED1}}$
16	DVSS4	46	DVDD4	76	SD14	106	$\overline{\text{LED0}}$
17	SA2	47	IRQ	77	SD7	107	DVDD1
18	SA3	48	$\overline{\text{REF}}$	78	SD15	108	PRDB7
19	SA4	49	$\overline{\text{IOR}}$	79	DVSS12	109	PRDB6
20	DVSS10	50	$\overline{\text{IOW}}$	80	RXD-	110	PRDB5
21	SA5	51	$\overline{\text{SMEMR}}$	81	RXD+	111	PRDB4
22	SA6	52	DVSS11	82	AVDD4	112	PRDB3
23	SA7	53	AEN	83	TXP-	113	DVSS2
24	SA8	54	IOCHRDY	84	TXD-	114	PRDB2
25	DVSS5	55	RESET	85	TXP+	115	PRDB1
26	SA9	56	$\overline{\text{SLEEP}}$	86	TXD+	116	PRDB0
27	SA10	57	IOAM0	87	AVDD3	117	TDI
28	SA11	58	IOAM1	88	XTAL1	118	TDO
29	DVDD3	59	DVDD5	89	AVSS2	119	TMS
30	SA12	60	SD0	90	XTAL2	120	TCK

PIN DESIGNATIONS: BUS MASTER

Listed by Pin Name

Name	Pin #	Name	Pin #	Name	Pin #	Name	Pin #
AEN	53	DVSS8	64	PRDB2	114	$\overline{\text{SBHE}}$	13
$\overline{\text{APCS}}$	3	DVSS9	74	PRDB3	112	SD0	60
AVDD1	94	DVSS10	20	PRDB4	111	SD1	62
AVDD2	99	DVSS11	52	PRDB5	110	SD2	65
AVDD3	87	DVSS12	79	PRDB6	109	SD3	67
AVDD4	82	DXCVR	100	PRDB7	108	SD4	70
AVSS1	91	IOAM0	57	$\overline{\text{REF}}$	48	SD5	72
AVSS2	89	IOAM1	58	RESET	55	SD6	75
$\overline{\text{BPCS}}$	4	IOCHRDY	54	RXD-	80	SD7	77
CI-	97	$\overline{\text{IOCS16}}$	45	RXD+	81	SD8	61
CI+	98	$\overline{\text{IOR}}$	49	SA0	14	SD9	63
$\overline{\text{DACK}}$	44	$\overline{\text{IOW}}$	50	SA1	15	SD10	66
DI-	95	IRQ	47	SA2	17	SD11	68
DI+	96	LA17	5	SA3	18	SD12	71
DO-	92	LA18	6	SA4	19	SD13	73
DO+	93	LA19	7	SA5	21	SD14	76
DRQ	42	LA20	9	SA6	22	SD15	78
DVDD1	107	LA21	10	SA7	23	$\overline{\text{SLEEP}}$	56
DVDD2	1	LA22	11	SA8	24	$\overline{\text{SMEMR}}$	51
DVDD3	29	LA23	12	SA9	26	TCK	120
DVDD4	46	$\overline{\text{LED0}}$	106	SA10	27	TDI	117
DVDD5	59	$\overline{\text{LED1}}$	105	SA11	28	TDO	118
DVDD6	69	$\overline{\text{LED2}}$	103	SA12	30	$\overline{\text{TE}}$	2
DVSS1	104	$\overline{\text{LED3}}$	102	SA13	31	TMS	119
DVSS2	113	$\overline{\text{MASTER}}$	41	SA14	32	TXD-	84
DVSS3	8	MAUSEL/ $\overline{\text{EAR}}$	101	SA15	33	TXD+	86
DVSS4	16	$\overline{\text{MEMR}}$	40	SA16	35	TXP-	83
DVSS5	25	$\overline{\text{MEMW}}$	39	SA17	36	TXP+	85
DVSS6	34	PRDB0	116	SA18	37	XTAL1	88
DVSS7	43	PRDB1	115	SA19	38	XTAL2	90

PIN DESIGNATIONS: BUS MASTER
Listed by Group

Pin Name	Pin Function	I/O	Driver
ISA Bus Interface			
AEN	Address Enable	I	
$\overline{\text{DACK}}$	DMA Acknowledge	I	
DRQ	DMA Request	O	TS3
IOCHRDY	I/O Channel Ready	I/O	OD3
$\overline{\text{IOCS16}}$	I/O Chip Select 16	I/O	OD3
$\overline{\text{IOR}}$	I/O Read Select	I	
$\overline{\text{IOW}}$	I/O Write Select	I	
IRQ	Interrupt Request	O	OD3
LA17-23	Unlatched Address Bus	O	TS3
$\overline{\text{MASTER}}$	Master Transfer in Progress	O	OC3
$\overline{\text{MEMR}}$	Memory Read Select	O	TS3
$\overline{\text{MEMW}}$	Memory Write Select	O	TS3
$\overline{\text{REF}}$	Memory Refresh Active	I	
RESET	System Reset	I	
SA0-19	System Address Bus	I/O	TS3
$\overline{\text{SBHE}}$	System Byte High Enable	I/O	TS3
SD0-15	System Data Bus	I/O	TS3
$\overline{\text{SMEMR}}$	System Memory Read Select	I	
Board Interfaces			
$\overline{\text{APCS}}$	Address PROM Chip Select	O	TS1
$\overline{\text{BPCS}}$	Boot PROM Chip Select	O	TS1
DXCVR	Disable Transceiver	O	TS1
IOAM0-1	Input/Output Address Map	I	
$\overline{\text{LED0}}$	LED0/LNKST	O	TS2
$\overline{\text{LED1}}$	LED1/SFBD/RCVACT	O	TS2
$\overline{\text{LED2}}$	LED2/SRD/RXPOL	O	TS2
$\overline{\text{LED3}}$	LED3/SRDCLK/XMTACT	O	TS2
$\overline{\text{MAUSEL/EAR}}$	MAU SElect/External Address Reject	I	
PRDB0-7	PROM Data Bus	I	
$\overline{\text{SLEEP}}$	Sleep Mode	I	
$\overline{\text{TE}}$	Test Enable	I	
XTAL1	Crystal Input	I	
XTAL2	Crystal Output	O	

PIN DESIGNATIONS: BUS MASTER (continued)**Listed by Group**

Pin Name	Pin Function	I/O	Driver
Attachment Unit Interface (AUI)			
CI±	Collision Inputs	I	
DI±	Receive Data	I	
DO±	Transmit Data	O	
Twisted Pair Transceiver Interface (10BASE-T)			
RXD±	10BASE-T Receive Data	I	
TXD±	10BASE-T Transmit Data	O	
TXP±	10BASE-T Predistortion Control	O	
IEEE 1149.1 Test Access Port Interface (JTAG)			
TCK	Test Clock	I	
TDI	Test Data Input	I	
TDO	Test Data Output	O	TS2
TMS	Test Mode Select	I	
Power Supplies			
AVDD	Analog Power		
AVSS	Analog Ground		
DVDD	Digital Power		
DVSS	Digital Ground		

Table: Output Driver Types

Name	Type	I _{ol} (mA)	I _{oh} (mA)	pF
TS1	Tri-State	4	-1	50
TS2	Tri-State	12	-4	50
TS3	Tri-State	24	-3	120
OD3	Open Drain	24	-3	120

PIN DESCRIPTION: BUS MASTER MODE

These pins are part of the bus master mode. In order to understand the pin descriptions, definition of some terms from a draft of IEEE P996 are included.

IEEE P996 Terminology

Alternate Master: Any device that can take control of the bus through assertion of the $\overline{\text{MASTER}}$ signal. It has the ability to generate addresses and bus control signals in order to perform bus operations. All Alternate Masters must be 16 bit devices and drive $\overline{\text{SBHE}}$.

Bus Ownership: The Current Master possesses bus ownership and can assert any bus control, address and data lines.

Current Master: The Permanent Master, Temporary Master or Alternate Master which currently has ownership of the bus.

Permanent Master: Each P996 bus will have a device known as the Permanent Master that provides certain signals and bus control functions as described in Section 3.5 (of the IEEE P996 spec), "Permanent Master". The Permanent Master function can reside on a Bus Adapter or on the backplane itself.

Temporary Master: A device that is capable of generating a DMA request to obtain control of the bus and directly asserting only the memory and I/O strobes during bus transfer. Addresses are generated by the DMA device on the Permanent Master.

ISA Interface

AEN

Address Enable *Input*

This signal must be driven LOW when the bus performs an I/O access to the device.

$\overline{\text{DACK}}$

DMA Acknowledge *Input*

Asserted LOW when the Permanent Master acknowledges a DMA request. When $\overline{\text{DACK}}$ is asserted the PCnet-ISA controller becomes the Current Master by asserting the $\overline{\text{MASTER}}$ signal.

DRQ

DMA Request *Output*

When the PCnet-ISA controller needs to perform a DMA transfer, it asserts DRQ. The Permanent Master acknowledges DRQ with assertion of $\overline{\text{DACK}}$. When the PCnet-ISA controller does not need the bus it deasserts DRQ.

IOCHRDY

I/O Channel Ready *Input/Output*

When the PCnet-ISA controller is being accessed, IOCHRDY HIGH indicates that valid data exists on the

data bus for reads and that data has been latched for writes. When the PCnet-ISA controller is the Current Master on the ISA bus, it extends the bus cycle as long as IOCHRDY is LOW.

$\overline{\text{IOCS16}}$

I/O Chip Select 16 *Input/Output*

When an I/O read or write operation is performed, the PCnet-ISA controller will drive the $\overline{\text{IOCS16}}$ pin LOW to indicate that the chip supports a 16-bit operation at this address. (If the motherboard does not receive this signal, then the motherboard will convert a 16-bit access to two 8-bit accesses.) The $\overline{\text{IOCS16}}$ pin is also an input and must go HIGH at least once after reset for the PCnet-ISA controller to perform 16-bit I/O operations. If this pin is grounded then the PCnet-ISA controller only performs 8-bit I/O operations.

The PCnet-ISA controller follows the IEEE P996 specification that recommends this function be implemented as a pure decode of SA0-9 and AEN, with no dependency on $\overline{\text{SMEMR}}$, $\overline{\text{MEMR}}$, $\overline{\text{MEMW}}$, $\overline{\text{IOR}}$, or $\overline{\text{IOW}}$; however, some PC/AT clone systems are not compatible with this approach. For this reason, the PCnet-ISA controller is recommended to be configured to run 8-bit I/O on all machines. Since data is moved by memory cycles there is virtually no performance loss incurred by running 8-bit I/O and compatibility problems are virtually eliminated. The PCnet-ISA controller can be configured to run 8-bit-only I/O by disconnecting the $\overline{\text{IOCS16}}$ pin from the ISA bus and tying the $\overline{\text{IOCS16}}$ pin to ground instead.

$\overline{\text{IOR}}$

I/O Read *Input*

$\overline{\text{IOR}}$ is driven LOW by the host to indicate that an Input/Output Read operation is taking place. $\overline{\text{IOR}}$ is only valid if the AEN signal is LOW and the external address matches the PCnet-ISA controller's predefined I/O address location. If valid, $\overline{\text{IOR}}$ indicates that a slave read operation is to be performed.

$\overline{\text{IOW}}$

I/O Write *Input*

$\overline{\text{IOW}}$ is driven LOW by the host to indicate that an Input/Output Write operation is taking place. $\overline{\text{IOW}}$ is only valid if AEN signal is LOW and the external address matches the PCnet-ISA controller's predefined I/O address location. If valid, $\overline{\text{IOW}}$ indicates that a slave write operation is to be performed.

IRQ

Interrupt Request *Output*

An attention signal which indicates that one or more of the following status flags is set: BABL, MISS, MERR, RINT, IDON, RCVCCO, JAB, MFCO, or TXSTRT. All status flags have a mask bit which allows for suppression of INTR assertion. These flags have the following meaning:

BABL	Babble
RCVCCO	Receive Collision Count Overflow
JAB	Jabber
MISS	Missed Frame
MERR	Memory Error
MFCO	Missed Frame Count Overflow
RINT	Receive Interrupt
IDON	Initialization Done
TXSTRT	Transmit Start

LA17-23**Unlatched Address Bus** *Output*

The unlatched address bus is driven by the PCnet-ISA controller during bus master cycle.

The functions of these unlatched address pins will change when GPSI mode is invoked. The table below shows the pin configuration in GPSI mode. Please refer to the section on General Purpose Serial Interface for detailed information on accessing this mode.

Pin Number	Pin Function in Bus Master Mode	Pin Function in GPSI Mode
5	LA17	RXDAT
6	LA18	SRDCLK
7	LA19	RXCRES
9	LA20	CLSN
10	LA21	STDCLK
11	LA22	TXEN
12	LA23	TXDAT

MASTER**Master Mode** *Output*

This signal indicates that the PCnet-ISA controller has become the Current Master of the ISA bus. After the PCnet-ISA controller has received a DMA Acknowledge (\overline{DACK}) in response to a DMA Request (DRQ), the Ethernet controller asserts the \overline{MASTER} signal to indicate to the Permanent Master that the PCnet-ISA controller is becoming the Current Master.

MEMR**Memory Read** *Output*

\overline{MEMR} goes LOW to perform a memory read operation.

MEMW**Memory Write** *Output*

\overline{MEMW} goes LOW to perform a memory write operation.

REF**Memory Refresh** *Input*

When \overline{REF} is asserted, a memory refresh is active. The PCnet-ISA controller uses this signal to mask inadvertent DMA Acknowledge assertion during memory

refresh periods. If \overline{DACK} is asserted when \overline{REF} is active, \overline{DACK} assertion is ignored. \overline{REF} is monitored to eliminate a bus arbitration problem observed on some ISA platforms.

RESET**Reset** *Input*

When RESET is asserted HIGH the PCnet-ISA controller performs an internal system reset. RESET must be held for a minimum of 10 XTAL1 periods before being deasserted. While in a reset state, the PCnet-ISA controller will tristate or deassert all outputs to predefined reset levels. The PCnet-ISA controller resets itself upon power-up.

SA0-19**System Address Bus** *Input/Output*

This bus contains address information, which is stable during a bus operation, regardless of the source. SA17-19 contain the same values as the unlatched address LA17-19. When the PCnet-ISA controller is the Current Master, SA0-19 will be driven actively. When the PCnet-ISA controller is not the Current Master, the SA0-19 lines are continuously monitored to determine if an address match exists for I/O slave transfers or Boot PROM accesses.

SBHE**System Byte High Enable** *Input/Output*

This signal indicates the high byte of the system data bus is to be used. \overline{SBHE} is driven by the PCnet-ISA controller when performing bus mastering operations.

SD0-15**System Data Bus** *Input/Output*

These pins are used to transfer data to and from the PCnet-ISA controller to system resources via the ISA data bus. SD0-15 is driven by the PCnet-ISA controller when performing bus master writes and slave read operations. Likewise, the data on SD0-15 is latched by the PCnet-ISA controller when performing bus master reads and slave write operations.

SMEMR**System Memory Read** *Input*

This pin is used during Boot PROM access. The Boot PROM can be disabled by not connecting this pin.

Board Interface**APCS****Address PROM Chip Select** *Output*

This signal is asserted when the external Address PROM is read. When an I/O read operation is performed on the first 16 bytes in the PCnet-ISA controller's I/O space, APCS is asserted. The outputs of the external Address PROM drive the PROM Data Bus. The PCnet-ISA controller buffers the contents of the PROM data bus and drives them on the lower eight bits of the System Data Bus.

BPCS
Boot PROM Chip Select *Output*

This signal is asserted when the Boot PROM is read. If SA0-19 lines match a predefined address block and $\overline{\text{SMEMR}}$ is active and $\overline{\text{REF}}$ inactive, the $\overline{\text{BPCS}}$ signal will be asserted. The outputs of the external Boot PROM drive the PROM Data Bus. The PCnet-ISA controller buffers the contents of the PROM data bus and drives them on the lower eight bits of the System Data Bus.

DXCVR
Disable Transceiver *Output*

This pin disables the transceiver. The DXCVR output is configured in the initialization sequence. A HIGH level indicates the Twisted Pair port is active and the AUI port is inactive, or SLEEP mode has been entered. A LOW level indicates the AUI port is active and the Twisted Pair port is inactive.

IOAM0-1
Input/Output Address Map *Input*

These inputs configure I/O address space for the PCnet-ISA controller and memory address space for the optional Remote Boot PROM with user selectable jumpers. The pins are pulled HIGH internally. The SA1-9 inputs are used for I/O address comparisons and the SA14-19 inputs are used for Boot PROM matching.

IOAM1,0	I/O Base	Memory Base
0 0	300 Hex	C8000 Hex
0 1	320 Hex	CC000 Hex
1 0	340 Hex	D0000 Hex
1 1	360 Hex	D4000 Hex

LED0-3
LED Drivers *Output*

These pins sink 12 mA each for driving LEDs. Their meaning is software configurable (see section *ISA Bus Configuration Registers*) and they are active LOW.

When EADI mode is selected, the pins named $\overline{\text{LED1}}$, $\overline{\text{LED2}}$, and $\overline{\text{LED3}}$ change in function while $\overline{\text{LED0}}$ continues to indicate 10BASE-T Link Status. The MAUSEL input becomes the $\overline{\text{EAR}}$ input.

LED	EADI Function
1	SF/BD
2	SRD
3	SRDCLK

MAUSEL/ $\overline{\text{EAR}}$
**MAU Select/
External Address Reject** *Input*

This pin selects the 10BASE-T MAU when HIGH and the AUI interface when LOW if the XMAUSEL register bit in ISACSR2 (ISA Configuration Register) is set. If the XMAUSEL register bit is cleared, the MAUSEL pin is ignored and the network interface is software selected. This pin has a default value of HIGH if left unconnected.

If EADI mode is selected, this pin becomes the $\overline{\text{EAR}}$ input. The incoming frame will be checked against the internally active address detection mechanisms and the result of this check will be OR'd with the value on the $\overline{\text{EAR}}$ pin. The $\overline{\text{EAR}}$ pin is defined as $\overline{\text{REJECT}}$. See the EADI section for details regarding the function and timing of this signal.

PRDB0-7
Private Data Bus *Input*

This is the data bus for the Boot PROM and the Address PROM.

SLEEP
Sleep *Input*

When $\overline{\text{SLEEP}}$ pin is asserted (active LOW), the PCnet-ISA controller performs an internal system reset and proceeds into a power savings mode. All outputs will be placed in their normal reset condition. All PCnet-ISA controller inputs will be ignored except for the $\overline{\text{SLEEP}}$ pin itself. Deassertion of $\overline{\text{SLEEP}}$ results in wake-up. The system must delay the starting of the network controller by 0.5 seconds to allow internal analog circuits to stabilize.

 $\overline{\text{TE}}$
Test Enable *Input*

This pin is for factory use only. It has a default value of HIGH if left unconnected. It is recommended that this pin always be connected to V_{DD} .

XTAL1
Crystal Connection *Input*

The internal clock generator uses a 20 MHz crystal that is attached to pins XTAL1 and XTAL2. Alternatively, an external 20 MHz CMOS-compatible clock signal can be used to drive this pin. Refer to the section on External Crystal Characteristics for more details.

XTAL2
Crystal Connection *Output*

The internal clock generator uses a 20 MHz crystal that is attached to pins XTAL1 and XTAL2. If an external clock is used, this pin should be left unconnected.

BLOCK DIAGRAM: SHARED MEMORY MODE

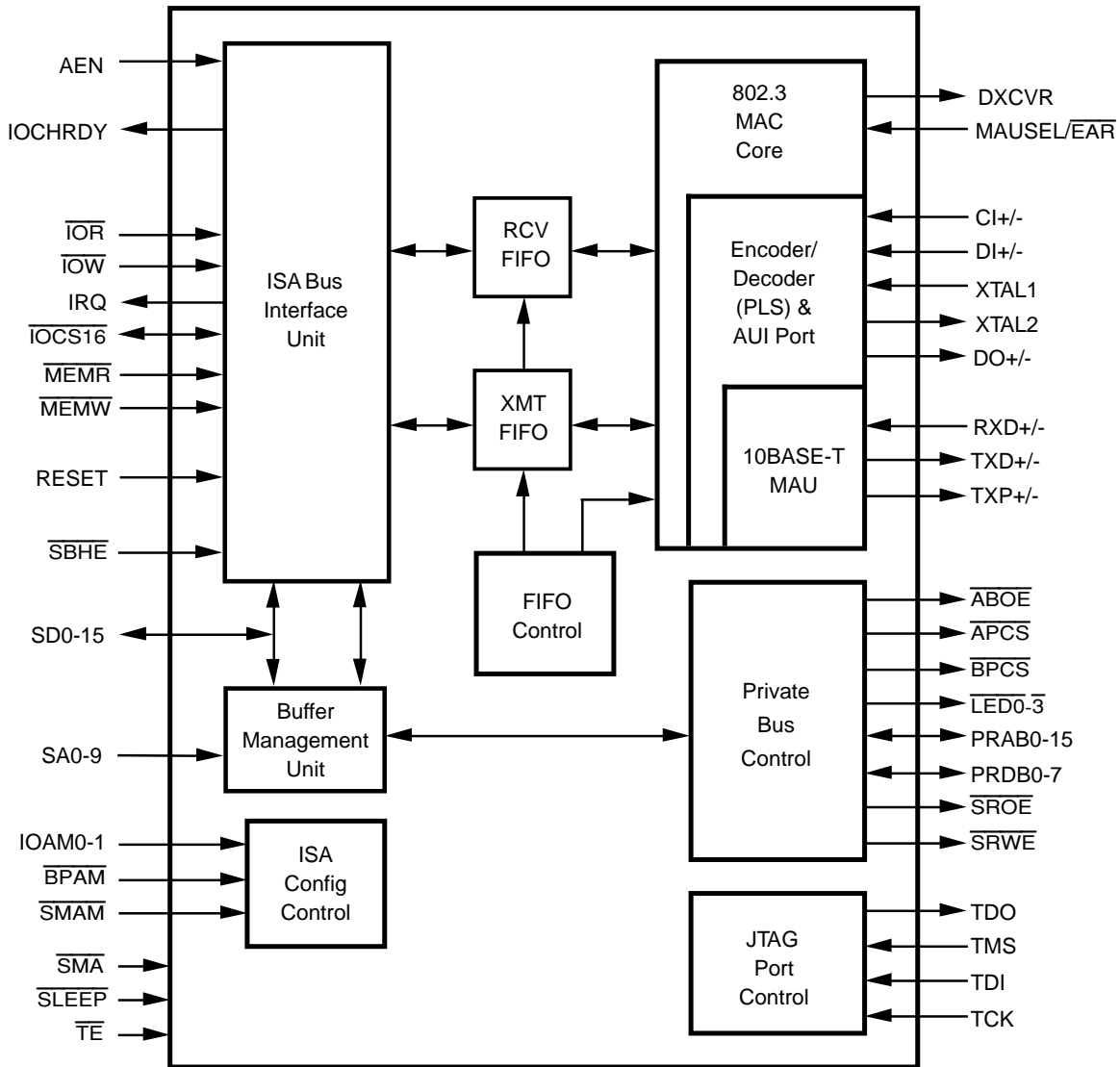

16907B-2

CONNECTION DIAGRAM: SHARED MEMORY

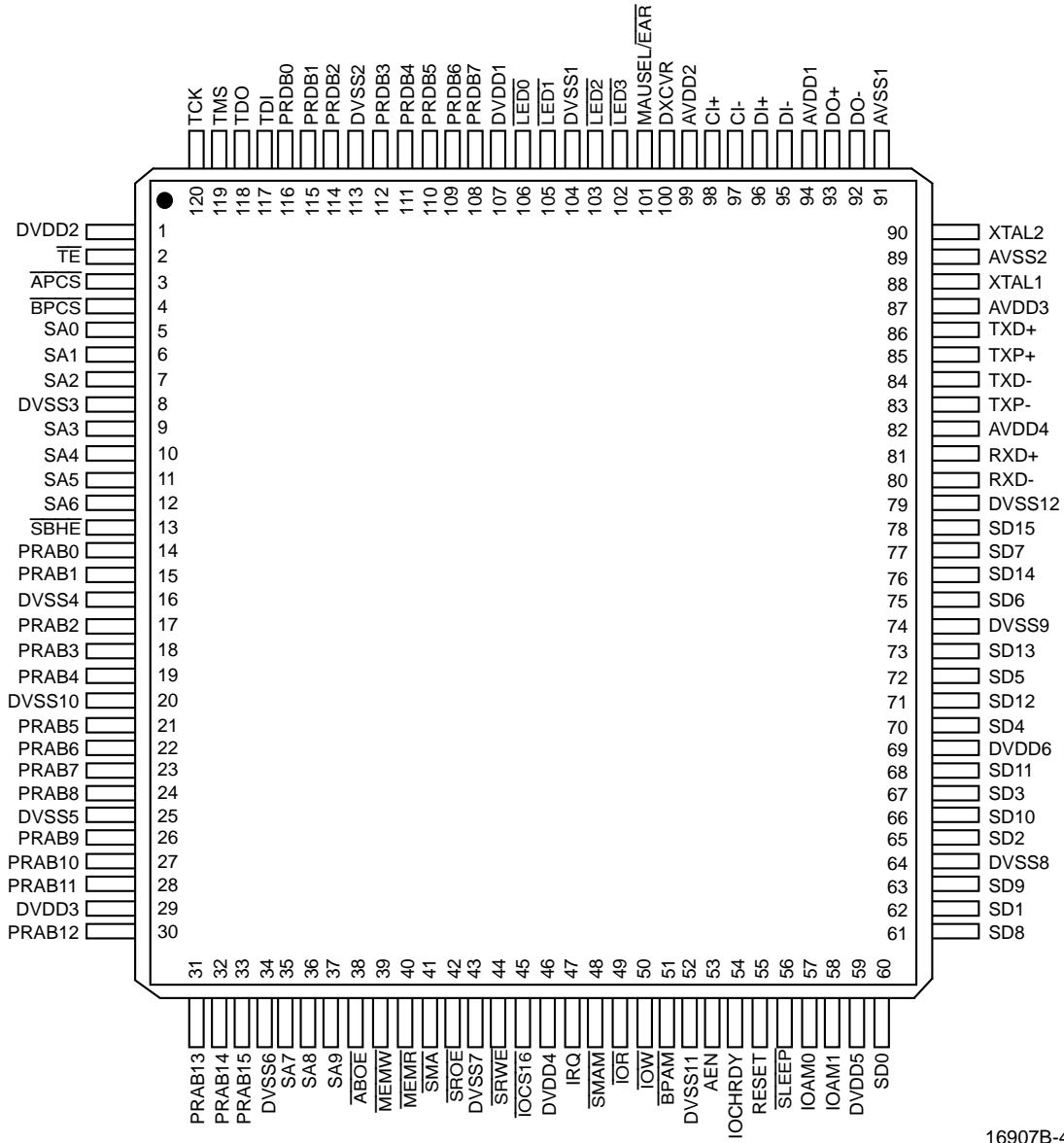

16907B-4

PIN DESIGNATIONS: SHARED MEMORY**Listed by Pin Number**

Pin #	Name	Pin #	Name	Pin #	Name	Pin #	Name
1	DVDD2	31	PRAB13	61	SD8	91	AVSS1
2	\overline{TE}	32	PRAB14	62	SD1	92	DO-
3	\overline{APCS}	33	PRAB15	63	SD9	93	DO+
4	\overline{BPCS}	34	DVSS6	64	DVSS8	94	AVDD1
5	SA0	35	SA7	65	SD2	95	DI-
6	SA1	36	SA8	66	SD10	96	DI+
7	SA2	37	SA9	67	SD3	97	CI-
8	DVSS3	38	\overline{ABOE}	68	SD11	98	CI+
9	SA3	39	\overline{MEMW}	69	DVDD6	99	AVDD2
10	SA4	40	\overline{MEMR}	70	SD4	100	DXCVR
11	SA5	41	\overline{SMA}	71	SD12	101	MAUSEL/ \overline{EAR}
12	SA6	42	\overline{SROE}	72	SD5	102	$\overline{LED3}$
13	\overline{SBHE}	43	DVSS7	73	SD13	103	$\overline{LED2}$
14	PRAB0	44	\overline{SRWE}	74	DVSS9	104	DVSS1
15	PRAB1	45	$\overline{IOCS16}$	75	SD6	105	$\overline{LED1}$
16	DVSS4	46	DVDD4	76	SD14	106	$\overline{LED0}$
17	PRAB2	47	IRQ	77	SD7	107	DVDD1
18	PRAB3	48	\overline{SMAM}	78	SD15	108	PRDB7
19	PRAB4	49	\overline{IOR}	79	DVSS12	109	PRDB6
20	DVSS10	50	\overline{IOW}	80	RXD-	110	PRDB5
21	PRAB5	51	\overline{BPAM}	81	RXD+	111	PRDB4
22	PRAB6	52	DVSS11	82	AVDD4	112	PRDB3
23	PRAB7	53	AEN	83	TXP-	113	DVSS2
24	PRAB8	54	IOCHRDY	84	TXD-	114	PRDB2
25	DVSS5	55	RESET	85	TXP+	115	PRDB1
26	PRAB9	56	\overline{SLEEP}	86	TXD+	116	PRDB0
27	PRAB10	57	IOAM0	87	AVDD3	117	TDI
28	PRAB11	58	IOAM1	88	XTAL1	118	TDO
29	DVDD3	59	DVDD5	89	AVSS2	119	TMS
30	PRAB12	60	SD0	90	XTAL2	120	TCK

PIN DESIGNATIONS: SHARED MEMORY

Listed by Pin Name

Name	Pin #	Name	Pin #	Name	Pin #	Name	Pin #
$\overline{\text{ABOE}}$	38	DVSS8	64	PRAB10	27	SD2	65
AEN	53	DVSS9	74	PRAB11	28	SD3	67
$\overline{\text{APCS}}$	3	DVSS10	20	PRAB12	30	SD4	70
AVDD1	94	DVSS11	52	PRAB13	31	SD5	72
AVDD2	99	DVSS12	79	PRAB14	32	SD6	75
AVDD3	87	DXCVR	100	PRAB15	33	SD7	77
AVDD4	82	IOAM0	57	PRDB0	116	SD8	61
AVSS1	91	IOAM1	58	PRDB1	115	SD9	63
AVSS2	89	IOCHRDY	54	PRDB2	114	SD10	66
$\overline{\text{BPAM}}$	51	$\overline{\text{IOCS16}}$	45	PRDB3	112	SD11	68
$\overline{\text{BPCS}}$	4	$\overline{\text{IOR}}$	49	PRDB4	111	SD12	71
CI-	97	$\overline{\text{IOW}}$	50	PRDB5	110	SD13	73
CI+	98	IRQ	47	PRDB6	109	SD14	76
DI-	95	$\overline{\text{LED0}}$	106	PRDB7	108	SD15	78
DI+	96	$\overline{\text{LED1}}$	105	RESET	55	$\overline{\text{SLEEP}}$	56
DO-	92	$\overline{\text{LED2}}$	103	RXD-	80	$\overline{\text{SMA}}$	41
DO+	93	$\overline{\text{LED3}}$	102	RXD+	81	$\overline{\text{SMAM}}$	48
DVDD1	107	$\overline{\text{MAUSEL/EAR}}$	101	SA0	5	$\overline{\text{SROE}}$	42
DVDD2	1	$\overline{\text{MEMR}}$	40	SA1	6	$\overline{\text{SRWE}}$	44
DVDD3	29	$\overline{\text{MEMW}}$	39	SA2	7	TCK	120
DVDD4	46	PRAB0	14	SA3	9	TDI	117
DVDD5	59	PRAB1	15	SA4	10	TDO	118
DVDD6	69	PRAB2	17	SA5	11	$\overline{\text{TE}}$	2
DVSS1	104	PRAB3	18	SA6	12	TMS	119
DVSS2	113	PRAB4	19	SA7	35	TXD-	84
DVSS3	8	PRAB5	21	SA8	36	TXD+	86
DVSS4	16	PRAB6	22	SA9	37	TXP-	83
DVSS5	25	PRAB7	23	$\overline{\text{SBHE}}$	13	TXP+	85
DVSS6	34	PRAB8	24	SD0	60	XTAL1	88
DVSS7	43	PRAB9	26	SD1	62	XTAL2	90

PIN DESIGNATIONS: SHARED MEMORY**Listed by Group**

Pin Name	Pin Function	I/O	Driver
ISA Bus Interface			
AEN	Address Enable	I	
IOCHRDY	I/O Channel Ready	O	OD3
$\overline{\text{IOCS16}}$	I/O Chip Select 16	I/O	OD3
$\overline{\text{IOR}}$	I/O Read Select	I	
$\overline{\text{IOW}}$	I/O Write Select	I	
IRQ	Interrupt Request	O	OD3
$\overline{\text{MEMR}}$	Memory Read Select	I	
$\overline{\text{MEMW}}$	Memory Write Select	I	
RESET	System Reset	I	
SA0-9	System Address Bus	I	
$\overline{\text{SBHE}}$	System Byte High Enable	I	
SD0-15	System Data Bus	I/O	TS3
Board Interfaces			
$\overline{\text{ABOE}}$	Address Buffer Output Enable	O	TS3
$\overline{\text{APCS}}$	Address PROM Chip Select	O	TS1
$\overline{\text{BPAM}}$	Boot PROM Address Match	I	
$\overline{\text{BPCS}}$	Boot PROM Chip Select	O	TS1
DXCVR	Disable Transceiver	O	TS1
IOAM0-1	Input/Output Address Map	I	
$\overline{\text{LED0}}$	LED0/LNKST	O	TS2
$\overline{\text{LED1}}$	LED1	O	TS2
$\overline{\text{LED2}}$	LED2	O	TS2
$\overline{\text{LED3}}$	LED3	O	TS2
$\overline{\text{MAUSEL/EAR}}$	MAU SElect/External Address Reject	I	
PRAB0-15	PRivate Address Bus	I/O	TS3
PRDB0-7	PRivate Data Bus	I/O	TS1
$\overline{\text{SLEEP}}$	Sleep Mode	I	
$\overline{\text{SMA}}$	Shared Memory Architecture	I	
$\overline{\text{SMAM}}$	Shared Memory Address Match	I	
$\overline{\text{SROE}}$	Static RAM Output Enable	O	TS3
$\overline{\text{SRWE}}$	Static RAM Write Enable	O	TS1
$\overline{\text{TE}}$	Test Enable	I	
XTAL1	Crystal Oscillator Input	I	
XTAL2	Crystal Oscillator OUTPUT	O	

PIN DESIGNATIONS: SHARED MEMORY (continued)
Listed by Group

Pin Name	Pin Function	I/O	Driver
Attachment Unit Interface (AUI)			
CI±	Collision Inputs	I	
DI±	Receive Data	I	
DO±	Transmit Data	O	
Twisted Pair Transceiver Interface (10BASE-T)			
RXD±	10BASE-T Receive Data	I	
TXD±	10BASE-T Transmit Data	O	
TXP±	10BASE-T Predistortion Control	O	
IEEE 1149.1 Test Access Port Interface (JTAG)			
TCK	Test Clock	I	
TDI	Test Data Input	I	
TDO	Test Data Output	O	TS2
TMS	Test Mode Select	I	
Power Supplies			
AVDD	Analog Power		
AVSS	Analog Ground		
DVDD	Digital Power		
DVSS	Digital Ground		

Table: Output Driver Types

Name	Type	I _{ol} (mA)	I _{oh} (mA)	pF
TS1	Tri-State	4	-1	50
TS2	Tri-State	12	-4	50
TS3	Tri-State	24	-3	120
OD3	Open Drain	24	-3	120

PIN DESCRIPTION: SHARED MEMORY MODE

ISA Interface

AEN

Address Enable *Input*

This signal must be driven LOW when the bus performs an I/O access to the device.

IOCHRDY

I/O Channel Ready *Output*

When the PCnet-ISA controller is being accessed, a HIGH on IOCHRDY indicates that valid data exists on the data bus for reads and that data has been latched for writes.

IOCS16

I/O Chip Select 16 *Input/Output*

When an I/O read or write operation is performed, the PCnet-ISA controller will drive this pin LOW to indicate that the chip supports a 16-bit operation at this address. (If the motherboard does not receive this signal, then the motherboard will convert a 16-bit access to two 8-bit accesses.) The $\overline{\text{IOCS16}}$ pin is also an input and must go HIGH at least once after reset for the PCnet-ISA controller to perform 16-bit I/O operations. If this pin is grounded then the PCnet-ISA controller only performs 8-bit I/O operations.

The PCnet-ISA controller follows the IEEE P996 specification that recommends this function be implemented as a pure decode of SA0-9 and AEN, with no dependency on $\overline{\text{SMEMR}}$, $\overline{\text{MEMR}}$, $\overline{\text{MEMW}}$, $\overline{\text{IOR}}$, or $\overline{\text{IOW}}$; however, some PC/AT clone systems are not compatible with this approach. For this reason, the PCnet-ISA controller is recommended to be configured to run 8-bit I/O on all machines. Since data is moved by memory cycles there is virtually no performance loss incurred by running 8-bit I/O and compatibility problems are virtually eliminated. The PCnet-ISA controller can be configured to run 8-bit-only I/O by disconnecting the $\overline{\text{IOCS16}}$ pin from the ISA bus and tying the $\overline{\text{IOCS16}}$ pin to ground instead.

$\overline{\text{IOR}}$

I/O Read *Input*

To perform an Input/Output Read operation on the device $\overline{\text{IOR}}$ must be asserted. $\overline{\text{IOR}}$ is only valid if the AEN signal is LOW and the external address matches the PCnet-ISA controller's predefined I/O address location. If valid, $\overline{\text{IOR}}$ indicates that a slave read operation is to be performed.

$\overline{\text{IOW}}$

I/O Write *Input*

To perform an Input/Output write operation on the device $\overline{\text{IOW}}$ must be asserted. $\overline{\text{IOW}}$ is only valid if AEN signal is LOW and the external address matches the PCnet-ISA controller's predefined I/O address location. If valid, $\overline{\text{IOW}}$ indicates that a slave write operation is to be performed.

IRQ

Interrupt Request *Output*

An attention signal which indicates that one or more of the following status flags is set: BABL, MISS, MERR, RINT, IDON or TXSTRT. All status flags have a mask bit which allows for suppression of INTR assertion. These flags have the following meaning:

BABL	Babble
RCVCCO	Receive Collision Count Overflow
JAB	Jabber
MISS	Missed Frame
MERR	Memory Error
MFCO	Missed Frame Count Overflow
RINT	Receive Interrupt
IDON	Initialization Done
TXSTRT	Transmit Start

$\overline{\text{MEMR}}$

Memory Read *Input*

$\overline{\text{MEMR}}$ goes LOW to perform a memory read operation.

$\overline{\text{MEMW}}$

Memory Write *Input*

$\overline{\text{MEMW}}$ goes LOW to perform a memory write operation.

RESET

Reset *Input*

When RESET is asserted HIGH, the PCnet-ISA controller performs an internal system reset. RESET must be held for a minimum of 10 XTAL1 periods before being deasserted. While in a reset state, the PCnet-ISA controller will tristate or deassert all outputs to predefined reset levels. The PCnet-ISA controller resets itself upon power-up.

SA0-9

System Address Bus *Input*

This bus carries the address inputs from the system address bus. Address data is stable during command active cycle.

$\overline{\text{SBHE}}$

System Bus High Enable *Input*

This signal indicates the HIGH byte of the system data bus is to be used. There is a weak pull-up resistor on this pin. If the PCnet-ISA controller is installed in an 8-bit only system like the PC/XT, $\overline{\text{SBHE}}$ will always be HIGH and the PCnet-ISA controller will perform only 8-bit operations. There must be at least one LOW going edge on this signal before the PCnet-ISA controller will perform 16-bit operations.

SD0-15
System Data Bus
Input/Output

This bus is used to transfer data to and from the PCnet-ISA controller to system resources via the ISA data bus. SD0-15 is driven by the PCnet-ISA controller when performing slave read operations.

Likewise, the data on SD0-15 is latched by the PCnet-ISA controller when performing slave write operations.

Board Interface
ABOE
Address Buffer Output Enable *Output*

This pin goes LOW to enable an external octal buffer to drive the contents of SA10-15 onto PRAB10-15. Only six of the eight buffers are needed.

APCS
Address PROM Chip Select *Output*

This signal is asserted when the external Address PROM is read. When an I/O read operation is performed on the first 16 bytes in the PCnet-ISA controller's I/O space, APCS is asserted. The outputs of the external Address PROM drive the PROM Data Bus. The PCnet-ISA controller buffers the contents of the PROM data bus and drives them on the lower eight bits of the System Data Bus. $\overline{\text{IOCS16}}$ is not asserted during this cycle.

BPAM
Boot PROM Address Match *Input*

This pin indicates a Boot PROM access cycle. If no Boot PROM is installed, this pin has a default value of HIGH and thus may be left connected to V_{DD} .

BPCS
Boot PROM Chip Select *Output*

This signal is asserted when the Boot PROM is read. If $\overline{\text{BPAM}}$ is active and $\overline{\text{MEMR}}$ is active, the $\overline{\text{BPCS}}$ signal will be asserted. The outputs of the external Boot PROM drive the PROM Data Bus. The PCnet-ISA controller buffers the contents of the PROM data bus and drives them on the System Data Bus. $\overline{\text{IOCS16}}$ is not asserted during this cycle. If 16-bit cycles are performed, it is the responsibility of external logic to assert $\overline{\text{MEMCS16}}$ signal.

DXCVR
Disable Transceiver
Output

This pin disables the transceiver. A high level indicates the Twisted Pair Interface is active and the AUI interface is inactive, or SLEEP mode has been entered. A low level indicates the AUI interface is active and the Twisted Pair interface is inactive.

IOAM0-1
Input/Output Address Map
Input

These inputs configure I/O address space for the PCnet-ISA controller. The pins have an on-chip pullup resistor and are pulled HIGH internally. The SA1-9 inputs are used for I/O address comparisons.

IOAM1,0	I/O Base
0 0	300 Hex
0 1	320 Hex
1 0	340 Hex
1 1	360 Hex

LED0-3
LED Drivers
Output

These pins sink 12 mA each for driving LEDs. Their meaning is software configurable (see section *ISA Bus Configuration Registers*) and they are active LOW.

When EADI mode is selected, the pins named $\overline{\text{LED1}}$, $\overline{\text{LED2}}$, and $\overline{\text{LED3}}$ change in function while $\overline{\text{LED0}}$ continues to indicate 10BASE-T Link Status. The MAUSEL input becomes the $\overline{\text{EAR}}$ input.

LED	EADI Function
1	SF/BD
2	SRD
3	SRDCLK

MAUSEL/ $\overline{\text{EAR}}$
MAU Select/
External Address Reject
Input

This pin selects the 10BASE-T MAU when HIGH and the AUI interface when LOW if the XMAUSEL register bit in ISACSR2 (ISA Configuration Register) is set. If the XMAUSEL register bit is cleared, the MAUSEL pin is ignored and the network interface is software selected. This pin has a default value of HIGH if left unconnected.

If EADI mode is selected, this pin becomes the $\overline{\text{EAR}}$ input. The incoming frame will be checked against the internally active address detection mechanisms and the result of this check will be OR'd with the value on the $\overline{\text{EAR}}$ pin. The $\overline{\text{EAR}}$ pin is defined as $\overline{\text{REJECT}}$. See the EADI section for details regarding the function and timing of this signal.

PRAB0-15
Private Address Bus
Input/Output

The Private Address Bus is the address bus used to drive the Address PROM, Remote Boot PROM, and SRAM. PRAB10-15 are required to be buffered by a Bus Buffer with $\overline{\text{ABOE}}$ as its control and SA10-15 as its inputs.

PRDB0-7**Private Data Bus***Input/Output*

This is the data bus for the static RAM, the Boot PROM, and the Address PROM.

SLEEP**Sleep***Input*

When $\overline{\text{SLEEP}}$ input is asserted (active LOW), the PCnet-ISA controller performs an internal system reset and proceeds into a power savings mode. All outputs will be placed in their normal reset condition. All PCnet-ISA controller inputs will be ignored except for the $\overline{\text{SLEEP}}$ pin itself. Deassertion of $\overline{\text{SLEEP}}$ results in wake-up. The system must delay the starting of the network controller by 0.5 seconds to allow internal analog circuits to stabilize.

SMA**Shared Memory Architecture***Input*

This pin is sampled after the hardware RESET sequence. The pin must be pulled permanently LOW for operation in the shared memory mode.

SMAM**Shared Memory Address Match***Input*

This pin indicates an access to shared memory when active. The type of access is decided by $\overline{\text{MEMR}}$ or $\overline{\text{MEMW}}$.

SROE**Static RAM Output Enable***Output*

This pin directly controls the external SRAM's $\overline{\text{OE}}$ pin.

SRWE**Static RAM Write Enable***Output*

This pin directly controls the external SRAM's $\overline{\text{WE}}$ pin.

TE**Test Enable***Input*

This pin is for factory use only. It has a default value of HIGH if left unconnected. It is strongly recommended that this pin always be connected to V_{DD} .

XTAL1**Crystal Connection***Input*

The internal clock generator uses a 20 MHz crystal that is attached to pins XTAL1 and XTAL2. Alternatively, an external 20 MHz CMOS-compatible clock signal can be used to drive this pin. Refer to the section on External Crystal Characteristics for more details.

XTAL2**Crystal Connection***Output*

The internal clock generator uses a 20 MHz crystal that is attached to pins XTAL1 and XTAL2. If an external clock is used, this pin should be left unconnected.

PIN DESCRIPTION: NETWORK INTERFACES

AUI Interface

CI+, CI-

Control Input

Input

This is a differential input pair used to detect Collision (Signal Quality Error Signal).

DI+, DI-

Data In

Input

This is a differential receive data input pair to the PCnet-ISA controller.

DO+, DO-

Data Out

Output

This is a differential transmit data output pair from the PCnet-ISA controller.

Twisted Pair Interface

RXD+, RXD-

Receive Data

Input

This is the 10BASE-T port differential receive input pair.

TXD+, TXD-

Transmit Data

Output

These are the 10BASE-T port differential transmit drivers.

TXP+, TXP-

Transmit Predistortion Control *Output*

These are 10BASE-T transmit waveform pre-distortion control differential outputs.

PIN DESCRIPTION

IEEE 1149.1 (JTAG) TEST ACCESS PORT

TCK

Test Clock

Input

This is the clock input for the boundary scan test mode operation. TCK can operate up to 10 MHz. If left unconnected, this pin has a default value of HIGH.

TDI

Test Data Input

Input

This is the test data input path to the PCnet-ISA controller. If left unconnected, this pin has a default value of HIGH.

TDO

Test Data Output

Output

This is the test data output path from the PCnet-ISA controller. TDO is tri-stated when JTAG port is inactive.

TMS

Test Mode Select

Input

This is a serial input bit stream used to define the specific boundary scan test to be executed. If left unconnected, this pin has a default value of HIGH.

PIN DESCRIPTION: POWER SUPPLIES

All power pins with a “D” prefix are digital pins connected to the digital circuitry and digital I/O buffers. All power pins with an “A” prefix are analog power pins connected to the analog circuitry. Not all analog pins are quiet and special precaution must be taken when doing board layout. Some analog pins are more noisy than others and must be separated from the other analog pins.

AVDD1–4**Analog Power (4 Pins) *Power***

Supplies power to analog portions of the PCnet-ISA controller. Special attention should be paid to the printed circuit board layout to avoid excessive noise on these lines. These supply lines should be kept separate from the DVDD supply pins and as far back to the power supply as is practically possible. AVDD3 is an exception and should be connected to DVDD supply and away from remaining AVDD supply pins. See the table below for more details.

AVSS1–2**Analog Ground (2 Pins) *Power***

Supplies ground reference to analog portions of PCnet-ISA controller. Special attention should be paid

to the printed circuit board layout to avoid excessive noise on these lines. These supply lines should be kept separate from the DVSS ground pins and as far back to the power supply as is practically possible. AVSS1 is an exception and should be connected to DVSS supply and away from remaining AVSS supply pins. See the table below for more details.

DVDD1–6**Digital Power (6 Pins) *Power***

Supplies power to digital portions of PCnet-ISA controller. Four pins are used by Input/Output buffer drivers and two are used by the internal digital circuitry.

DVSS1–12**Digital Ground (12 Pins) *Power***

Supplies ground reference to digital portions of PCnet-ISA controller. Ten pins are used by Input/Output buffer drivers and two are used by the internal digital circuitry.

Analog Power Pins and the Circuits to Which They are Connected

Analog Power	Analog Ground	Circuit	Comments
AVDD2 and AVDD4	AVSS2	These pins are connected to the analog voltage reference circuit and VCO.	These pins should be kept quiet. They should be kept separated with low- and high-frequency by-pass capacitors.
AVDD1		These pins are connected to analog circuits such as AUI and Twisted Pair receive logic.	These pins are moderately quiet and should be connected to the VDD supply a short distance away from the DVDD pins.
AVDD3	AVSS1	These pins are connected to the AUI and Twisted Pair drivers.	These pins are more noisy and should be connected to the DVDD/DVSS supplies.

FUNCTIONAL DESCRIPTION

The PCnet-ISA controller is a highly integrated system solution for the PC-AT ISA architecture. It provides an Ethernet controller, AUI port, and 10BASE-T transceiver. The PCnet-ISA controller can be directly interfaced to an ISA system bus. The PCnet-ISA controller contains an ISA bus interface unit, DMA Buffer Management Unit, 802.3 Media Access Control function, separate 136-byte transmit and 128-byte receive FIFOs, IEEE defined Attachment Unit Interface (AUI), and Twisted-Pair Transceiver Media Attachment Unit. In addition, a Sleep function has been incorporated which provides low standby current for power sensitive applications.

The PCnet-ISA controller is register compatible with the LANCE (Am7990) Ethernet controller and PCnet-ISA+ controller (Am79C961). The DMA Buffer Management Unit supports the LANCE descriptor software model and the PCnet-ISA controller is software compatible with the Novell NE2100 and NE1500T add-in cards.

External remote boot and Ethernet physical address PROMs are supported. The location of the I/O registers and PROMs are configured by selected pins and internal address comparators (in bus master mode) or external logic (in shared memory mode).

The PCnet-ISA controller's bus master architecture brings to system manufacturers (adapter card and motherboard makers alike) something they have not been able to enjoy with other architectures—a low-cost system solution that provides the lowest parts count and highest performance. As a bus-mastering device, costly and power-hungry external SRAMs are not needed for packet buffering. This results in lower system cost due to fewer components, less real-estate and less power. The PCnet-ISA controller's advanced bus mastering architecture also provides high data throughput and low CPU utilization for even better performance.

To offer greater flexibility, the PCnet-ISA controller has a shared memory mode to meet varying application needs. The shared memory architecture is compatible

with very low-end machines, such as PC/XTs that do not support bus mastering, and very high end machines which require local packet buffering for increased system latency.

The network interface provides an Attachment Unit Interface and Twisted-Pair Transceiver functions. Only one interface is active at any particular time. The AUI allows for connection via isolation transformer to 10BASE5 and 10BASE2, thick and thin based coaxial cables. The Twisted-Pair Transceiver interface allows for connection of unshielded twisted-pair cables as specified by the Section 14 supplement to IEEE 802.3 Standard (Type 10BASE-T).

Bus Master Mode

System Interface

The PCnet-ISA controller has two fundamental operating modes, Bus Master and Shared Memory. The selection of either the Bus Master mode or the Shared Memory mode must be done through hard wiring; it is not software configurable. The Bus Master mode provides an Am7990 (LANCE) compatible Ethernet controller, an Ethernet Address PROM, a Boot PROM, and a set of device configuration registers.

The optional Boot PROM is in memory address space and is expected to be 16 kilobytes or less in size. The memory address is always related to the I/O address. For example, 0x300 is always associated with 0xC8000. On-chip address comparators control device selection based on the value of the input pins IOAM0 and IOAM1. The SMEMR input pin can be left unconnected for applications where a Remote Boot PROM is not needed.

The address PROM, board configuration registers, and the Ethernet controller occupy 24 bytes of I/O space and can be located on four different starting addresses.

Data buffers are located in motherboard memory and can be accessed by the PCnet-ISA controller when the device becomes the Current Master.

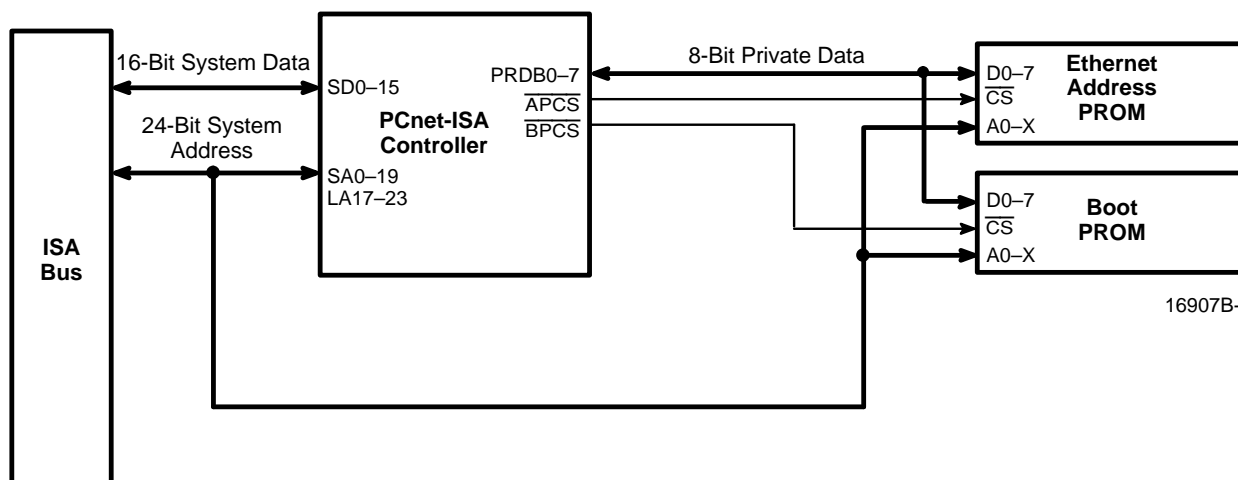

16907B-5

Bus Master Block Diagram

Shared Memory Mode

System Interface

The Shared Memory mode is the other fundamental operating mode available on the PCnet-ISA controller. The PCnet-ISA controller uses the same descriptor and buffer architecture as the LANCE, but these data structures are stored in static RAM controlled by the PCnet-ISA controller. The static RAM is visible as a memory resource to the PC. The other resources look the same as in the Bus Master mode.

The Boot PROM is selected by an external device which drives the Boot PROM Address Match (BPAM) input to the PCnet-ISA controller. The PCnet-ISA controller can perform two 8-bit accesses from the 8-bit Boot PROM and present 16-bits of data. The shared memory works the same way, with an external device generating Shared Memory Address Match and the PCnet-ISA controller performing the read or write and the 8 to 16-bit data conversion.

Converting shared memory accesses from 8-bit cycles to 16-bit cycles allows use of the much faster 16-bit cycle timing while cutting the number of bus cycles in half. This raises performance to more than 400% of what could be achieved with 8-bit cycles. Converting boot PROM accesses to 16-bit cycles allows the two memory resources to be in the same 128 Kbyte block of memory without a clash between two devices with different data widths.

Note that the external address buffer must drive all the bits of PRAB10-15 even if the static RAM is less than 64 Kbytes. The PCnet-ISA controller uses an internal

address comparator to perform SRAM prefetches on the Private Data Bus; the PRAB0-15 signals are used internally to determine whether a SRAM read cycle prefetch is a match or a miss.

Access to the Ethernet controller registers, board configuration registers, and Address PROM is done with on-chip address comparators.

Network Interface

The PCnet-ISA controller can be connected to an IEEE 802.3 network via one of two network interface ports. The Attachment Unit Interface (AUI) provides an IEEE 802.3 compliant differential interface to a remote MAU or a transceiver on the system board. The 10BASE-T interface provides a twisted-pair Ethernet port. The PCnet-ISA controller provides three modes of network interface selection: automatic selection, software selection, and jumper selection of AUI or 10BASE-T interface.

In the automatic selection mode, the PCnet-ISA controller will select the interface that is connected to the network by checking the Link Status state machine. If both AUI and 10BASE-T interfaces are connected, the 10BASE-T interface is selected over AUI. If the PCnet-ISA controller is initialized for software selection of network interface, it will read the PORTSEL [1:0] bits in the Mode register (CSR15.8 and CSR15.7) to determine which interface needs to be activated. For jumper selection of the network interface, the MAUSEL pin is used. When the XMAUSEL bit in ISACSR2 is set, a HIGH on the pin will select the 10BASE-T interface, and a LOW on the pin will select the AUI interface.

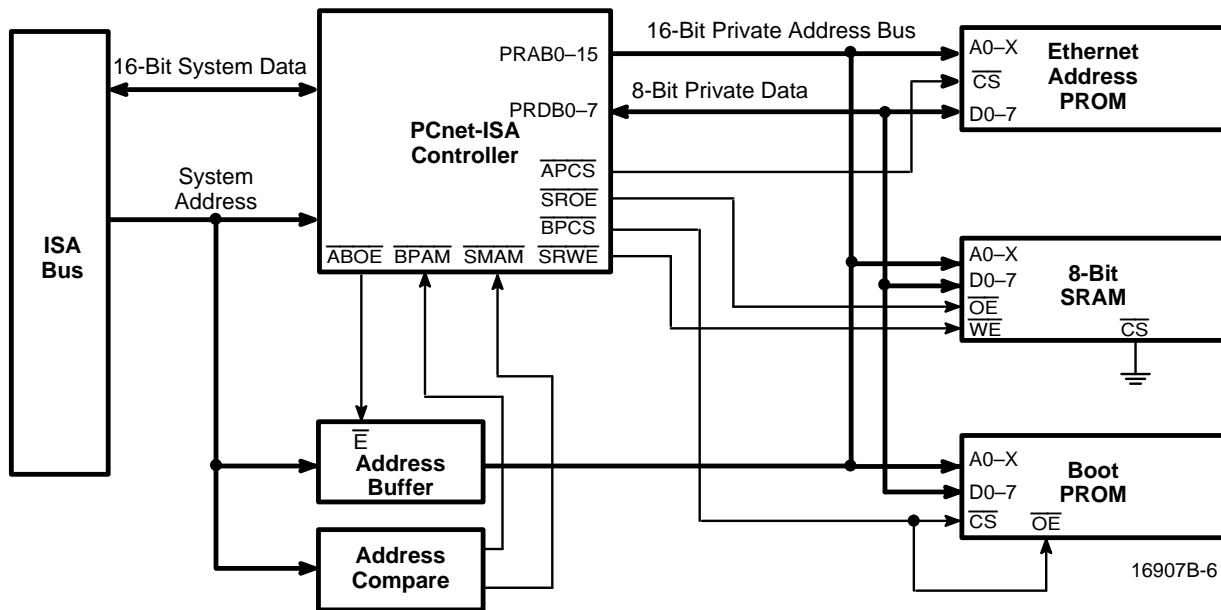

Shared Memory Block Diagram

DETAILED FUNCTIONS

Bus Interface Unit (BIU)

The bus interface unit is a mixture of a 20 MHz state machine and asynchronous logic. It handles two types of accesses: accesses where the PCnet-ISA controller is a slave and accesses where the PCnet-ISA controller is the Current Master.

In slave mode, signals like $\overline{\text{IOCS16}}$ are asserted and deasserted as soon as the appropriate inputs are received. IOCHRDY is asynchronously driven LOW if the PCnet-ISA controller needs a wait state. It is released synchronously when the PCnet-ISA controller is ready.

When the PCnet-ISA controller is the Current Master, all the signals it generates are synchronous to the on-chip 20 MHz clock.

DMA Transfers

The BIU will initiate DMA transfers according to the type of operation being performed. There are three primary types of DMA transfers:

1. Initialization Block DMA Transfers

Once the BIU has been granted bus mastership, it will perform four data transfer cycles (eight bytes) before relinquishing the bus. The four transfers within the mastership period will always be read cycles to contiguous addresses. There are 12 words to transfer so there will be three bus mastership periods.

2. Descriptor DMA Transfers

Once the BIU has been granted bus mastership, it will perform the appropriate number of data transfer cycles before relinquishing the bus. The transfers within the mastership period will always be of the same type (either all read or all write), but may be to non-contiguous addresses. Only the bytes which need to be read or written are accessed.

3. Burst-Cycle DMA Transfers

Once the BIU has been granted bus mastership, it will perform a series of consecutive data transfer cycles before relinquishing the bus. Each data transfer will be performed sequentially, with the issue of the address, and the transfer of the data with appropriate output signals to indicate selection of the active data bytes during the transfer. All transfers within the mastership cycle will be either read or write cycles, and will be to contiguous addresses. The number of data transfer cycles within the burst is dependent on the programming of the DMAPLUS option (CSR4, bit 14).

If DMAPLUS = 0, a maximum of 16 transfers will be performed. This may be changed by writing to the burst register (CSR80), but the default takes the same amount of time as the Am2100 family of LANCE-based boards, a little over 5 microseconds.

If DMAPLUS = 1, the burst will continue until the FIFO is filled to its high threshold (32 bytes in transmit operation) or emptied to its low threshold (16 bytes in receive operation). The exact number of transfer cycles in this

case will be dependent on the latency of the system bus to the BIU's mastership request and the speed of bus operation.

Buffer Management Unit (BMU)

The buffer management unit is a micro-coded 20 MHz state machine which implements the initialization block and the descriptor architecture.

Initialization

PCnet-ISA controller initialization includes the reading of the initialization block in memory to obtain the operating parameters. The initialization block is read when the INIT bit in CSR0 is set. The INIT bit should be set before or concurrent with the STRT bit to insure correct operation. Four words at a time are read and the bus is released at the end of each block of reads, for a total of three arbitration cycles. Once the initialization block has been read in and processed, the BMU knows where the receive and transmit descriptor rings are. On completion of the read operation and after internal registers have been updated, IDON will be set in CSR0, and an interrupt generated if IENA is set.

The Initialization Block is vectored by the contents of CSR1 (least significant 16 bits of address) and CSR2 (most significant 8 bits of address). The block contains the user defined conditions for PCnet-ISA controller operation, together with the address and length information to allow linkage of the transmit and receive descriptor rings.

There is an alternative method to initialize the PCnet-ISA controller. Instead of initialization via the initialization block in memory, data can be written directly into the appropriate registers. Either method may be used at the discretion of the programmer. If the registers are written to directly, the INIT bit must not be set, or the initialization block will be read in, thus overwriting the previously written information. Please refer to Appendix C for details on this alternative method.

Reinitialization

The transmitter and receiver section of the PCnet-ISA controller can be turned on via the initialization block (MODE Register DTX, DRX bits CSR15[1:0]). The state of the transmitter and receiver are monitored through CSR0 (RXON, TXON bits). The PCnet-ISA controller should be reinitialized if the transmitter and/or the receiver were not turned on during the original initialization and it was subsequently required to activate them, or if either section shut off due to the detection of an error condition (MERR, UFLO, TX BUFF error).

Reinitialization may be done via the initialization block or by setting the STOP bit in CSR0, followed by writing to CSR15, and then setting the START bit in CSR0. Note that this form of restart will not perform the same in the PCnet-ISA controller as in the LANCE. In particular, the PCnet-ISA controller reloads the transmit and receive descriptor pointers with their respective base ad-

addresses. This means that the software must clear the descriptor own bits and reset its descriptor ring pointers before the restart of the PCnet-ISA controller. The reload of descriptor base addresses is performed in the LANCE only after initialization, so a restart of the LANCE without initialization leaves the LANCE pointing at the same descriptor locations as before the restart.

Buffer Management

Buffer management is accomplished through message descriptor entries organized as ring structures in memory. There are two rings, a receive ring and a transmit ring. The size of a message descriptor entry is 4 words (8 bytes).

Descriptor Rings

Each descriptor ring must be organized in a contiguous area of memory. At initialization time (setting the INIT bit in CSR0), the PCnet-ISA controller reads the user-defined base address for the transmit and receive descriptor rings, which must be on an 8-byte boundary, as well as the number of entries contained in the descriptor rings. By default, a maximum of 128 ring entries is permitted when utilizing the initialization block, which uses values of TLEN and RLEN to specify the transmit and receive descriptor ring lengths. However, the ring lengths can be manually defined (up to 65535) by writing the transmit and receive ring length registers (CSR76,78) directly.

Each ring entry contains the following information:

- The address of the actual message data buffer in user or host memory
- The length of the message buffer

- Status information indicating the condition of the buffer

Receive descriptor entries are similar (but not identical) to transmit descriptor entries. Both are composed of four registers, each 16 bits wide for a total of 8 bytes.

To permit the queuing and de-queuing of message buffers, ownership of each buffer is allocated to either the PCnet-ISA controller or the host. The OWN bit within the descriptor status information, either TMD or RMD (see section on TMD or RMD), is used for this purpose. "Deadly Embrace" conditions are avoided by the ownership mechanism. Only the owner is permitted to relinquish ownership or to write to any field in the descriptor entry. A device that is not the current owner of a descriptor entry cannot assume ownership or change any field in the entry.

Descriptor Ring Access Mechanism

At initialization, the PCnet-ISA controller reads the base address of both the transmit and receive descriptor rings into CSRs for use by the PCnet-ISA controller during subsequent operation.

When transmit and receive functions begin, the base address of each ring is loaded into the current descriptor address registers and the address of the next descriptor entry in the transmit and receive rings is computed and loaded into the next descriptor address registers.

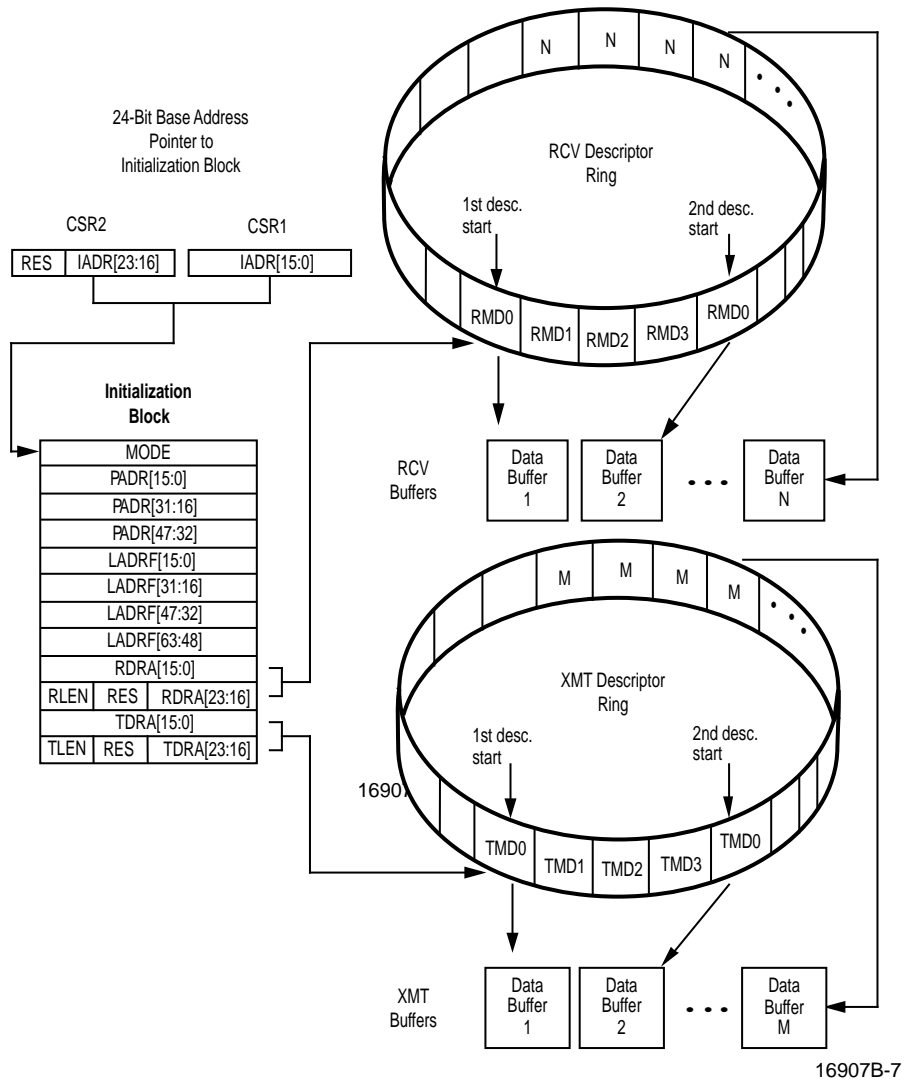

Initialization Block and Descriptor Rings

Polling

When there is no channel activity and there is no pre- or post-receive or transmit activity being performed by the PCnet-ISA controller, then the PCnet-ISA controller will periodically poll the current receive and transmit descriptor entries in order to ascertain their ownership. If the DPOLL bit in CSR4 is set, then the transmit polling function is disabled.

A typical polling operation consists of the following: The PCnet-ISA controller will use the current receive descriptor address stored internally to vector to the appropriate Receive Descriptor Table Entry (RDTE). It

will then use the current transmit descriptor address (stored internally) to vector to the appropriate Transmit Descriptor Table Entry (TDTE). These accesses will be made to RMD1 and RMD0 of the current RDTE and TMD1 and TMD0 of the current TDTE at periodic polling intervals. All information collected during polling activity will be stored internally in the appropriate CSRs. (i.e. CSR18–19, CSR20–21, CSR40, CSR42, CSR50, CSR52). UnOWNed descriptor status will be internally ignored.

A typical receive poll occurs under the following conditions:

- 1) PCnet-ISA controller does not possess ownership of the current RDTE and the poll time has elapsed and $RXON = 1$,

or

- 2) PCnet-ISA controller does not possess ownership of the next RDTE and the poll time has elapsed and $RXON = 1$.

If $RXON = 0$, the PCnet-ISA controller will never poll RDTE locations.

If $RXON=1$, the system should always have at least one RDTE available for the possibility of a receive event. When there is only one RDTE, there is no polling for next RDTE.

A typical transmit poll occurs under the following conditions:

- 1) PCnet-ISA controller does not possess ownership of the current TDTE and $DPOLL = 0$ and $TXON = 1$ and the poll time has elapsed,

or

- 2) PCnet-ISA controller does not possess ownership of the current TDTE and $DPOLL = 0$ and $TXON = 1$ and a packet has just been received,

or

- 3) PCnet-ISA controller does not possess ownership of the current TDTE and $DPOLL = 0$ and $TXON = 1$ and a packet has just been transmitted.

The poll time interval is nominally defined as 32,768 crystal clock periods, or 1.6 ms. However, the poll time register is controlled internally by microcode, so any other microcode controlled operation will interrupt the incrementing of the poll count register. For example, when a receive packet is accepted by the PCnet-ISA controller, the device suspends execution of the poll-time-incrementing microcode so that a receive microcode routine may instead be executed. Poll-time-incrementing code is resumed when the receive operation has completely finished. Note, however, that following the completion of any receive or transmit operation, a poll operation will always be performed. The poll time count register is never reset. Note that if a non-default value is desired, then a strict sequence of setting the INIT bit in CSR0, waiting for INITDONE, then writing to CSR47, and then setting STRT in CSR0 must be observed, otherwise the default value will not be overwritten. See the CSR47 section for details.

Setting the TDMD bit of CSR0 will cause the microcode controller to exit the poll counting code and immediately perform a polling operation. If RDTE ownership has not been previously established, then an RDTE poll will be performed ahead of the TDTE poll.

Transmit Descriptor Table Entry (TDTE)

If, after a TDTE access, the PCnet-ISA controller finds that the OWN bit of that TDTE is not set, then the PCnet-ISA controller resumes the poll time count and reexamines the same TDTE at the next expiration of the poll time count.

If the OWN bit of the TDTE is set, but $STP = 0$, the PCnet-ISA controller will immediately request the bus in order to reset the OWN bit of this descriptor; this condition would normally be found following a LCOL or RETRY error that occurred in the middle of a transmit packet chain of buffers. After resetting the OWN bit of this descriptor, the PCnet-ISA controller will again immediately request the bus in order to access the next TDTE location in the ring.

If the OWN bit is set and the buffer length is 0, the OWN bit will be reset. In the LANCE the buffer length of 0 is interpreted as a 4096-byte buffer. It is acceptable to have a 0 length buffer on transmit with $STP = 1$ or $STP = 1$ and $ENP = 1$. It is not acceptable to have 0 length buffer with $STP = 0$ and $ENP = 1$.

If the OWN bit is set and the start of packet (STP) bit is set, then microcode control proceeds to a routine that will enable transmit data transfers to the FIFO.

If the transmit buffers are data chained ($ENP=0$ in the first buffer), then the PCnet-ISA controller will look ahead to the next transmit descriptor after it has performed at least one transmit data transfer from the first buffer. More than one transmit data transfer may possibly take place, depending upon the state of the transmitter. The transmit descriptor lookahead reads TMD0 first and TMD1 second. The contents of TMD0 and TMD1 will be stored in Next TX Descriptor Address (CSR32), Next TX Byte Count (CSR66) and Next TX Status (CSR67) regardless of the state of the OWN bit. This transmit descriptor lookahead operation is performed only once.

If the PCnet-ISA controller does not own the next TDTE (i.e. the second TDTE for this packet), then it will complete transmission of the current buffer and then update the status of the current (first) TDTE with the BUFF and UFLO bits being set. This will cause the transmitter to be disabled ($CSR0, TXON = 0$). The PCnet-ISA controller will have to be restarted to restore the transmit function. The situation that matches this description implies that the system has not been able to stay ahead of the PCnet-ISA controller in the transmit descriptor ring and, therefore, the condition is treated as a fatal error. To avoid this situation, the system should always set the transmit chain descriptor own bits in reverse order.

If the PCnet-ISA controller does own the second TDTE in a chain, it will gradually empty the contents of the first buffer (as the bytes are needed by the transmit operation), perform a single-cycle DMA transfer to update the status (reset the OWN bit in TMD1) of the first descriptor, and then it may perform one data DMA access on the second buffer in the chain before executing another lookahead operation. (i.e. a lookahead to the third descriptor.)

The PCnet-ISA controller can queue up to two packets in the transmit FIFO. Call them packet "X" and packet "Y", where "Y" is after "X". Assume that packet "X" is currently being transmitted. Because the PCnet-ISA controller can perform lookahead data transfer over an ENP, it is possible for the PCnet-ISA controller to update a TDTE in a buffer belonging to packet "Y" while packet "X" is being transmitted if packet "Y" uses data chaining. This operation will result in non-sequential TDTE accesses as packet "X" completes transmission and the PCnet-ISA controller writes out its status, since packet "X"'s TDTE is before the TDTE accessed as part of the lookahead data transfer from packet "Y".

This should not cause any problem for properly written software which processes buffers in sequence, waiting for ownership before proceeding.

If an error occurs in the transmission before all of the bytes of the current buffer have been transferred, then TMD2 and TMD1 of the current buffer will be written; in that case, data transfers from the next buffer will not commence. Instead, following the TMD2/TMD1 update, the PCnet-ISA controller will go to the next transmit packet, if any, skipping over the rest of the packet which experienced an error, including chained buffers.

This is done by returning to the polling microcode where it will immediately access the next descriptor and find the condition $OWN = 1$ and $STP = 0$ as described earlier. In that case, the PCnet-ISA controller will reset the own bit for this descriptor and continue in like manner until a descriptor with $OWN = 0$ (no more transmit packets in the ring) or $OWN = 1$ and $STP = 1$ (the first buffer of a new packet) is reached.

At the end of any transmit operation, whether successful or with errors, and the completion of the descriptor updates, the PCnet-ISA controller will always perform another poll operation. As described earlier, this poll operation will begin with a check of the current RDTE, unless the PCnet-ISA controller already owns that descriptor. Then the PCnet-ISA controller will proceed to polling the next TDTE. If the transmit descriptor OWN bit has a zero value, then the PCnet-ISA controller will resume poll time count incrementation. If the transmit descriptor OWN bit has a value of ONE, then the PCnet-ISA controller will begin filling the FIFO with transmit data and initiate a transmission. This end-of-operation poll avoids inserting poll time counts between successive transmit packets.

Whenever the PCnet-ISA controller completes a transmit packet (either with or without error) and writes the status information to the current descriptor, then the

TINT bit of CSR0 is set to indicate the completion of a transmission. This causes an interrupt signal if the IENA bit of CSR0 has been set and the TINTM bit of CSR3 is reset.

Receive Descriptor Table Entry (RDTE)

If the PCnet-ISA controller does not own both the current and the next Receive Descriptor Table Entry, then the PCnet-ISA controller will continue to poll according to the polling sequence described above. If the receive descriptor ring length is 1, there is no next descriptor, and no look ahead poll will take place.

If a poll operation has revealed that the current and the next RDTE belongs to the PCnet-ISA controller, then additional poll accesses are not necessary. Future poll operations will not include RDTE accesses as long as the PCnet-ISA controller retains ownership to the current and the next RDTE.

When receive activity is present on the channel, the PCnet-ISA controller waits for the complete address of the message to arrive. It then decides whether to accept or reject the packet based on all active addressing schemes. If the packet is accepted the PCnet-ISA controller checks the current receive buffer status register CRST (CSR40) to determine the ownership of the current buffer.

If ownership is lacking, then the PCnet-ISA controller will immediately perform a (last ditch) poll of the current RDTE. If ownership is still denied, then the PCnet-ISA controller has no buffer in which to store the incoming message. The MISS bit will be set in CSR0 and an interrupt will be generated if $IENA = 1$ (CSR0) and $MISSM = 0$ (CSR3). Another poll of the current RDTE will not occur until the packet has finished.

If the PCnet-ISA controller sees that the last poll (either a normal poll or the last-ditch effort described in the above paragraph) of the current RDTE shows valid ownership, then it proceeds to a poll of the next RDTE. Following this poll, and regardless of the outcome of this poll, transfers of receive data from the FIFO may begin.

Regardless of ownership of the second receive descriptor, the PCnet-ISA controller will continue to perform receive data DMA transfers to the first buffer, using burst-cycle DMA transfers. If the packet length exceeds the length of the first buffer, and the PCnet-ISA controller does not own the second buffer, ownership of the current descriptor will be passed back to the system by writing a zero to the OWN bit of RMD1 and status will be written indicating buffer ($BUFF = 1$) and possibly overflow ($OFLO = 1$) errors.

If the packet length exceeds the length of the first (current) buffer, and the PCnet-ISA controller does own the second (next) buffer, ownership will be passed back to the system by writing a zero to the OWN bit of RMD1 when the first buffer is full. Receive data transfers to the second buffer may occur before the PCnet-ISA controller proceeds to look ahead to the ownership of the third buffer. Such action will depend upon the state of the FIFO when the status has been updated on the first de-

scriptor. In any case, lookahead will be performed to the third buffer and the information gathered will be stored in the chip, regardless of the state of the ownership bit. As in the transmit flow, lookahead operations are performed only once.

This activity continues until the PCnet-ISA controller recognizes the completion of the packet (the last byte of this receive message has been removed from the FIFO). The PCnet-ISA controller will subsequently update the current RDTE status with the end of packet (ENP) indication set, write the message byte count (MCNT) of the complete packet into RMD2 and overwrite the “current” entries in the CSRs with the “next” entries.

Media Access Control

The Media Access Control engine incorporates the essential protocol requirements for operation of a compliant Ethernet/802.3 node, and provides the interface between the FIFO sub-system and the Manchester Encoder/Decoder (MENDEC).

The MAC engine is fully compliant to Section 4 of ISO/IEC 8802-3 (ANSI/IEEE Standard 1990 Second Edition) and ANSI/IEEE 802.3 (1985).

The MAC engine provides programmable enhanced features designed to minimize host supervision and pre or post-message processing. These features include the ability to disable retries after a collision, dynamic FCS generation on a packet-by-packet basis, and automatic pad field insertion and deletion to enforce minimum frame size attributes.

The two primary attributes of the MAC engine are:

- Transmit and receive message data encapsulation
 - Framing (frame boundary delimitation, frame synchronization)
 - Addressing (source and destination address handling)
 - Error detection (physical medium transmission errors)
- Media access management
 - Medium allocation (collision avoidance)
 - Contention resolution (collision handling)

Transmit And Receive Message Data Encapsulation

The MAC engine provides minimum frame size enforcement for transmit and receive packets. When APAD_XMT = 1 (bit 11 in CSR4), transmit messages will be padded with sufficient bytes (containing 00h) to ensure that the receiving station will observe an information field (destination address, source address, length/type, data and FCS) of 64 bytes. When ASTRP_RCV = 1 (bit 10 in CSR4), the receiver will automatically strip pad bytes from the received message by observing the value in the length field, and stripping excess bytes if this value is below the minimum data size (46 bytes). Both features can be independently over-

ridden to allow illegally short (less than 64 bytes of packet data) messages to be transmitted and/or received.

Framing (Frame Boundary Delimitation, Frame Synchronization)

The MAC engine will autonomously handle the construction of the transmit frame. Once the Transmit FIFO has been filled to the predetermined threshold (set by XMTSP in CSR80), and providing access to the channel is currently permitted, the MAC engine will commence the 7-byte preamble sequence (10101010b, where first bit transmitted is a 1). The MAC engine will subsequently append the Start Frame Delimiter (SFD) byte (10101011b) followed by the serialized data from the Transmit FIFO. Once the data has been completed, the MAC engine will append the FCS (most significant bit first) which was computed on the entire data portion of the message.

Note that the user is responsible for the correct ordering and content in each of the fields in the frame, including the destination address, source address, length/type and packet data.

The receive section of the MAC engine will detect an incoming preamble sequence and lock to the encoded clock. The internal MENDEC will decode the serial bit stream and present this to the MAC engine. The MAC will discard the first 8 bits of information before searching for the SFD sequence. Once the SFD is detected, all subsequent bits are treated as part of the frame. The MAC engine will inspect the length field to ensure minimum frame size, strip unnecessary pad characters (if enabled), and pass the remaining bytes through the Receive FIFO to the host. If pad stripping is performed, the MAC engine will also strip the received FCS bytes, although the normal FCS computation and checking will occur. Note that apart from pad stripping, the frame will be passed unmodified to the host. If the length field has a value of 46 or greater, the MAC engine will not attempt to validate the length against the number of bytes contained in the message.

If the frame terminates or suffers a collision before 64 bytes of information (after SFD) have been received, the MAC engine will automatically delete the frame from the Receive FIFO, without host intervention.

Addressing (Source and Destination Address Handling)

The first 6 bytes of information after SFD will be interpreted as the destination address field. The MAC engine provides facilities for physical, logical, and broadcast address reception. In addition, multiple physical addresses can be constructed (perfect address filtering) using external logic in conjunction with the EADI™ interface.

Error Detection (Physical Medium Transmission Errors)

The MAC engine provides several facilities which report and recover from errors on the medium. In addition, the

network is protected from gross errors due to inability of the host to keep pace with the MAC engine activity.

On completion of transmission, the following transmit status is available in the appropriate TMD and CSR areas:

- The exact number of transmission retry attempts (ONE, MORE, or RTRY)
- Whether the MAC engine had to Defer (DEF) due to channel activity
- Loss of Carrier, indicating that there was an interruption in the ability of the MAC engine to monitor its own transmission. Repeated LCAR errors indicate a potentially faulty transceiver or network connection.
- Late Collision (LCOL) indicates that the transmission suffered a collision after the slot time. This is indicative of a badly configured network. Late collisions should not occur in a normal operating network.
- Collision Error (CERR) indicates that the transceiver did not respond with an SQE Test message within the predetermined time after a transmission completed. This may be due to a failed transceiver, disconnected or faulty transceiver drop cable, or the fact the transceiver does not support this feature (or the feature is disabled).

In addition to the reporting of network errors, the MAC engine will also attempt to prevent the creation of any network error due to the inability of the host to service the MAC engine. During transmission, if the host fails to keep the Transmit FIFO filled sufficiently, causing an underflow, the MAC engine will guarantee the message is either sent as a runt packet (which will be deleted by the receiving station) or has an invalid FCS (which will also cause the receiver to reject the message).

The status of each receive message is available in the appropriate RMD and CSR areas. FCS and Framing errors (FRAM) are reported, although the received frame is still passed to the host. The FRAM error will only be reported if an FCS error is detected and there are a non-integral number of bits in the message. The MAC engine will ignore up to seven additional bits at the end of a message (dribbling bits), which can occur under normal network operating conditions. The reception of eight additional bits will cause the MAC engine to de-serialize the entire byte, and will result in the received message and FCS being modified.

The PCnet-ISA controller can handle up to 7 dribbling bits when a received packet terminates. During the reception, the CRC is generated on every serial bit (including the dribbling bits) coming from the cable, although the internally saved CRC value is only updated on the eighth bit (on each byte boundary). The framing error is reported to the user as follows:

1. If the number of the dribbling bits are 1 to 7 and there is no CRC error, then there is no Framing error (FRAM = 0).
2. If the number of the dribbling bits are less than 8 and there is a CRC error, then there is also a Framing error (FRAM = 1).
3. If the number of dribbling bits = 0, then there is no Framing error. There may or may not be a CRC (FCS) error.

Counters are provided to report the Receive Collision Count and Runt Packet Count and used for network statistics and utilization calculations.

Note that if the MAC engine detects a received packet which has a 00b pattern in the preamble (after the first 8 bits, which are ignored), the entire packet will be ignored. The MAC engine will wait for the network to go inactive before attempting to receive the next packet.

Media Access Management

The basic requirement for all stations on the network is to provide fairness of channel allocation. The 802.3/Ethernet protocol defines a media access mechanism which permits all stations to access the channel with equality. Any node can attempt to contend for the channel by waiting for a predetermined time (Inter Packet Gap interval) after the last activity, before transmitting on the medium. The channel is a multidrop communications medium (with various topological configurations permitted) which allows a single station to transmit and all other stations to receive. If two nodes simultaneously contend for the channel, their signals will interact, causing loss of data (defined as a collision). It is the responsibility of the MAC to attempt to avoid and recover from a collision, to guarantee data integrity for the end-to-end transmission to the receiving station.

Medium Allocation (Collision Avoidance)

The IEEE 802.3 Standard (ISO/IEC 8802-3 1990) requires that the CSMA/CD MAC monitor the medium traffic by looking for carrier activity. When carrier is detected the medium is considered busy, and the MAC should defer to the existing message.

The IEEE 802.3 Standard also allows optional two part deferral after a receive message.

See ANSI/IEEE Std 802.3-1990 Edition, 4.2.3.2.1:

Note: It is possible for the PLS carrier sense indication to fail to be asserted during a collision on the media. If the deference process simply times the interpacket gap based on this indication it is possible for a short interFrame gap to be generated, leading to a potential reception failure of a subsequent frame. To enhance system robustness the following optional measures, as specified in 4.2.8, are recom-

mended when *InterFrameSpacingPart1* is other than zero:

- (1) Upon completing a transmission, start timing the interpacket gap, as soon as transmitting and carrierSense are both false.
- (2) When timing an interpacket gap following reception, reset the interpacket gap timing if carrier Sense becomes true during the first 2/3 of the interpacket gap timing interval. During the final 1/3 of the interval the timer shall not be reset to ensure fair access to the medium. An initial period shorter than 2/3 of the interval is permissible including zero."

The MAC engine implements the optional receive two part deferral algorithm, with a first part inter-frame-spacing time of 6.0 μ s. The second part of the inter-frame-spacing interval is therefore 3.6 μ s.

The PCnet-ISA controller will perform the two-part deferral algorithm as specified in Section 4.2.8 (Process Deferral). The Inter Packet Gap (IPG) timer will start timing the 9.6 μ s *InterFrameSpacing* after the receive carrier is de-asserted. During the first part deferral (*InterFrameSpacingPart1* - IFS1) the PCnet-ISA controller will defer any pending transmit frame and respond to the receive message. The IPG counter will be reset to zero continuously until the carrier de-asserts, at which point the IPG counter will resume the 9.6 μ s count once again. Once the IFS1 period of 6.0 μ s has elapsed, the PCnet-ISA controller will begin timing the second part deferral (*InterFrameSpacingPart2* - IFS2) of 3.6 μ s. Once IFS1 has completed, and IFS2 has commenced, the PCnet-ISA controller will not defer to a receive packet if a transmit packet is pending. This means that the PCnet-ISA controller will not attempt to receive the receive packet, since it will start to transmit, and generate a collision at 9.6 μ s. The PCnet-ISA controller will guarantee to complete the preamble (64-bit) and jam (32-bit) sequence before ceasing transmission and invoking the random backoff algorithm.

In addition, transmit two part deferral is implemented as an option which can be disabled using the *DXMT2PD* bit (*CSR3*). Two-part deferral after transmission is useful for ensuring that severe IPG shrinkage cannot occur in specific circumstances, causing a transmit message to follow a receive message so closely as to make them indistinguishable.

During the time period immediately after a transmission has been completed, the external transceiver (in the case of a standard AUI connected device), should generate the SQE Test message (a nominal 10 MHz burst of 5-15 Bit Times duration) on the *Cl±* pair (within 0.6 μ s – 1.6 μ s after the transmission ceases). During the time period in which the SQE Test message is expected the PCnet-ISA controller will not respond to receive carrier sense.

See *ANSI/IEEE Std 802.3-1990 Edition*, 7.2.4.6 (1)):

"At the conclusion of the output function, the DTE opens a time window during which it expects to see the signal_quality_error signal asserted on the Control In circuit. The time window begins when the CARRIER_STATUS becomes CARRIER_OFF. If execution of the output function does not cause CARRIER_ON to occur, no SQE test occurs in the DTE. The duration of the window shall be at least 4.0 μ s but no more than 8.0 μ s. During the time window the Carrier Sense Function is inhibited."

The PCnet-ISA controller implements a carrier sense "blinding" period within 0 – 4.0 μ s from deassertion of carrier sense after transmission. This effectively means that when transmit two part deferral is enabled (*DXMT2PD* is cleared) the IFS1 time is from 4 μ s to 6 μ s after a transmission. However, since IPG shrinkage below 4 μ s will rarely be encountered on a correctly configured network, and since the fragment size will be larger than the 4 μ s blinding window, then the IPG counter will be reset by a worst case IPG shrinkage/fragment scenario and the PCnet-ISA controller will defer its transmission. In addition, the PCnet-ISA controller will not restart the "blinding" period if carrier is detected within the 4.0 μ s – 6.0 μ s IFS1 period, but will commence timing of the entire IFS1 period.

Contention Resolution (Collision Handling)

Collision detection is performed and reported to the MAC engine by the integrated Manchester Encoder/Decoder (*MENDEC*).

If a collision is detected before the complete preamble/SFD sequence has been transmitted, the MAC Engine will complete the preamble/SFD before appending the jam sequence. If a collision is detected after the preamble/SFD has been completed, but prior to 512 bits being transmitted, the MAC Engine will abort the transmission, and append the jam sequence immediately. The jam sequence is a 32-bit all zeroes pattern.

The MAC Engine will attempt to transmit a frame a total of 16 times (initial attempt plus 15 retries) due to normal collisions (those within the slot time). Detection of collision will cause the transmission to be re-scheduled, dependent on the backoff time that the MAC Engine computes. If a single retry was required, the ONE bit will be set in the Transmit Frame Status (*TMD1* in the Transmit Descriptor Ring). If more than one retry was required, the MORE bit will be set. If all 16 attempts experienced collisions, the RTRY bit (in *TMD2*) will be set (ONE and MORE will be clear), and the transmit message will be flushed from the FIFO. If retries have been disabled by setting the *DRTY* bit in the *MODE* register (*CSR15*), the MAC Engine will abandon transmission of the frame on detection of the first collision. In this case, only the RTRY bit will be set and the transmit message will be flushed from the FIFO.

If a collision is detected after 512 bit times have been transmitted, the collision is termed a late collision. The

MAC Engine will abort the transmission, append the jam sequence, and set the LCOL bit. No retry attempt will be scheduled on detection of a late collision, and the FIFO will be flushed.

The IEEE 802.3 Standard requires use of a “truncated binary exponential backoff” algorithm which provides a controlled pseudo-random mechanism to enforce the collision backoff interval, before re-transmission is attempted.

See ANSI/IEEE Std 802.3-1990 Edition, 4.2.3.2.5:

“At the end of enforcing a collision (jamming), the CSMA/CD sublayer delays before attempting to re-transmit the frame. The delay is an integer multiple of slotTime. The number of slot times to delay before the nth re-transmission attempt is chosen as a uniformly distributed random integer r in the range:

$$0 \leq r < 2^k, \text{ where } k = \min(n, 10).”$$

The PCnet-ISA controller provides an alternative algorithm, which suspends the counting of the slot time/IPG during the time that receive carrier sense is detected. This algorithm aids in networks where large numbers of nodes are present, and numerous nodes can be in collision. The algorithm effectively accelerates the increase in the backoff time in busy networks, and allows nodes not involved in the collision to access the channel while the colliding nodes await a reduction in channel activity. Once channel activity is reduced, the nodes resolving the collision time out their slot time counters as normal.

Manchester Encoder/Decoder (MENDEC)

The integrated Manchester Encoder/Decoder provides the PLS (Physical Layer Signaling) functions required for a fully compliant IEEE 802.3 station. The MENDEC provides the encoding function for data to be transmitted on the network using the high accuracy on-board oscillator, driven by either the crystal oscillator or an external CMOS-level compatible clock. The MENDEC also provides the decoding function from data received from the network. The MENDEC contains a Power On Reset (POR) circuit, which ensures that all analog portions of the PCnet-ISA controller are forced into their correct state during power-up, and prevents erroneous data transmission and/or reception during this time.

External Crystal Characteristics

When using a crystal to drive the oscillator, the crystal specification shown in the table may be used to ensure less than ± 0.5 ns jitter at DO \pm .

Table : External Crystal Characteristics

Parameter	Min	Nom	Max	Units
1.Parallel Resonant Frequency		20		MHz
2.Resonant Frequency Error (CL = 20 pF)	-50		+50	PPM
3.Change in Resonant Frequency With Respect To Temperature (0° – 70° C; CL = 20 pF)*	-40		+40	PPM
4.Crystal Capacitance			20	pF
5.Motional Crystal Capacitance (C1)		0.022		pF
6.Series Resistance			25	Ω
7.Shunt Capacitance			7	pF
8.Drive Level			TBD	mW

* Requires trimming crystal spec; no trim is 50 ppm total

External Clock Drive Characteristics

When driving the oscillator from an external clock source, XTAL2 must be left floating (unconnected). An external clock having the following characteristics must be used to ensure less than ± 0.5 ns jitter at DO \pm :

Clock Frequency:	20 MHz $\pm 0.01\%$
Rise/Fall Time (tR/tF):	< 6 ns from 0.5 V to V _{DD} -0.5
XTAL1 HIGH/LOW Time (tHIGH/tLOW):	20 ns min
XTAL1 Falling Edge to Falling Edge Jitter:	< ± 0.2 ns at 2.5 V input (V _{DD} /2)

MENDEC Transmit Path

The transmit section encodes separate clock and NRZ data input signals into a standard Manchester encoded serial bit stream. The transmit outputs (DO \pm) are designed to operate into terminated transmission lines. When operating into a 78 Ω terminated transmission line, the transmit signaling meets the required output levels and skew for Cheapernet, Ethernet, and IEEE-802.3.

Transmitter Timing and Operation

A 20 MHz fundamental-mode crystal oscillator provides the basic timing reference for the MENDEC portion of the PCnet-ISA controller. The crystal input is divided by two to create the internal transmit clock reference. Both clocks are fed into the Manchester Encoder to generate the transitions in the encoded data stream. The internal transmit clock is used by the MENDEC to internally synchronize the Internal Transmit Data (ITXDAT) from the controller and Internal Transmit Enable (ITXEN). The internal transmit clock is also used as a stable bit-rate clock by the receive section of the MENDEC and controller.

The oscillator requires an external 0.005% crystal, or an external 0.01% CMOS-level input as a reference. The accuracy requirements, if an external crystal is used, are tighter because allowance for the on-chip oscillator must be made to deliver a final accuracy of 0.01%.

Transmission is enabled by the controller. As long as the ITXEN request remains active, the serial output of the controller will be Manchester encoded and appear at DO±. When the internal request is dropped by the controller, the differential transmit outputs go to one of two idle states, dependent on TSEL in the Mode Register (CSR15, bit 9):

TSEL LOW:	The idle state of DO± yields "zero" differential to operate transformer-coupled loads.
TSEL HIGH:	In this idle state, DO+ is positive with respect to DO- (logical HIGH).

Receive Path

The principal functions of the receiver are to signal the PCnet-ISA controller that there is information on the receive pair, and to separate the incoming Manchester encoded data stream into clock and NRZ data.

The receiver section (see Receiver Block Diagram) consists of two parallel paths. The receive data path is a zero threshold, wide bandwidth line receiver. The carrier path is an offset threshold bandpass detecting line

receiver. Both receivers share common bias networks to allow operation over a wide input common mode range.

Input Signal Conditioning

Transient noise pulses at the input data stream are rejected by the Noise Rejection Filter. Pulse width rejection is proportional to transmit data rate. DC inputs more negative than minus 100 mV are also suppressed.

The Carrier Detection circuitry detects the presence of an incoming data packet by discerning and rejecting noise from expected Manchester data, and controls the stop and start of the phase-lock loop during clock acquisition. Clock acquisition requires a valid Manchester bit pattern of 1010b to lock onto the incoming message.

When input amplitude and pulse width conditions are met at DI±, a clock acquisition cycle is initiated.

Clock Acquisition

When there is no activity at DI± (receiver is idle), the receive oscillator is phase-locked to the internal transmit clock. The first negative clock transition (bit cell center of first valid Manchester "0") after IRXCERS is asserted interrupts the receive oscillator. The oscillator is then restarted at the second Manchester "0" (bit time 4) and is phase-locked to it. As a result, the MENDEC acquires the clock from the incoming Manchester bit pattern in 4 bit times with a "1010" Manchester bit pattern.

ISRCLK and IRXDAT are enabled 1/4 bit time after clock acquisition in bit cell 5. IRXDAT is at a HIGH state when the receiver is idle (no ISRCLK). IRXDAT however, is undefined when clock is acquired and may remain HIGH or change to LOW state whenever ISRCLK is enabled. At 1/4 bit time through bit cell 5, the controller portion of the PCnet-ISA controller sees the first ISRCLK transition. This also strobes in the incoming fifth bit to the MENDEC as Manchester "1". IRXDAT may make a transition after the ISRCLK rising edge in bit cell 5, but its state is still undefined. The Manchester "1" at bit 5 is clocked to IRXDAT output at 1/4 bit time in bit cell 6.

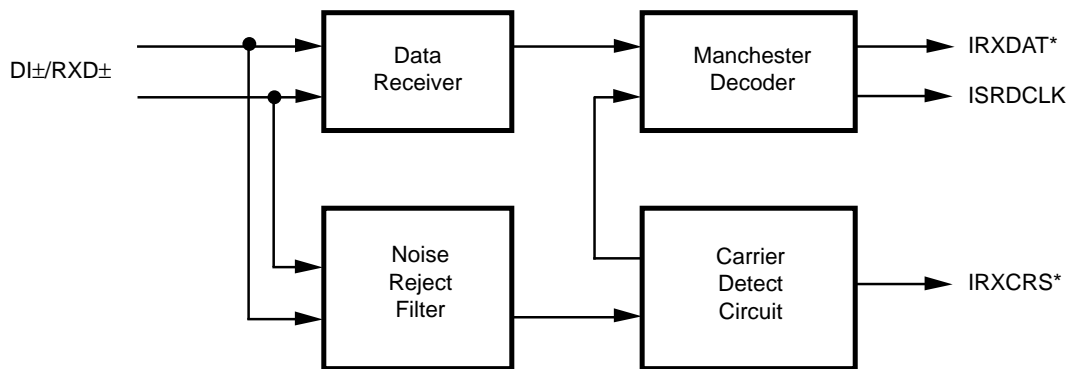

*Internal signal

16907B-8

Receiver Block Diagram

PLL Tracking

After clock acquisition, the phase-locked clock is compared to the incoming transition at the bit cell center (BCC) and the resulting phase error is applied to a correction circuit. This circuit ensures that the phase-locked clock remains locked on the received signal. Individual bit cell phase corrections of the Voltage Controlled Oscillator (VCO) are limited to 10% of the phase difference between BCC and phase-locked clock. Hence, input data jitter is reduced in ISRDCLK by 10 to 1.

Carrier Tracking and End of Message

The carrier detection circuit monitors the DI± inputs after IRXCERS is asserted for an end of message. IRXCERS de-asserts 1 to 2 bit times after the last positive transition on the incoming message. This initiates the end of reception cycle. The time delay from the last rising edge of the message to IRXCERS deassert allows the last bit to be strobed by ISRDCLK and transferred to the controller section, but prevents any extra bit(s) at the end of message.

Data Decoding

The data receiver is a comparator with clocked output to minimize noise sensitivity to the DI±/RXD± inputs. Input error is less than ± 35 mV to minimize sensitivity to input rise and fall time. ISRDCLK strobes the data receiver output at 1/4 bit time to determine the value of the Manchester bit, and clocks the data out on IRXDAT on the following ISRDCLK. The data receiver also generates the signal used for phase detector comparison to the internal MENDEC voltage controlled oscillator (VCO).

Jitter Tolerance Definition

The MENDEC utilizes a clock capture circuit to align its internal data strobe with an incoming bit stream. The clock acquisition circuitry requires four valid bits with the values 1010b. Clock is phase-locked to the negative transition at the bit cell center of the second “0” in the pattern.

Since data is strobed at 1/4 bit time, Manchester transitions which shift from their nominal placement through 1/4 bit time will result in improperly decoded data. With this as the criteria for an error, a definition of “Jitter Handling” is:

The peak deviation approaching or crossing 1/4 bit cell position from nominal input transition, for which the MENDEC section will properly decode data.

Attachment Unit Interface (AUI)

The AUI is the PLS (Physical Layer Signaling) to PMA (Physical Medium Attachment) interface which

connects the DTE to a MAU. The differential interface provided by the PCnet-ISA controller is fully compliant with Section 7 of ISO 8802-3 (ANSI/IEEE 802.3).

After the PCnet-ISA controller initiates a transmission, it will expect to see data “looped-back” on the DI± pair (when the AUI port is selected). This will internally generate a “carrier sense”, indicating that the integrity of the data path to and from the MAU is intact, and that the MAU is operating correctly. This “carrier sense” signal must be asserted within sometime before end of transmission. If “carrier sense” does not become active in response to the data transmission, or becomes inactive before the end of transmission, the loss of carrier (LCAR) error bit will be set in the Transmit Descriptor Ring (TMD3, bit 11) after the packet has been transmitted.

Differential Input Terminations

The differential input for the Manchester data (DI±) is externally terminated by two 40.2 Ω ±1% resistors and one optional common-mode bypass capacitor, as shown in the Differential Input Termination diagram below. The differential input impedance, ZIDF, and the common-mode input impedance, ZICM, are specified so that the Ethernet specification for cable termination impedance is met using standard 1% resistor terminators. If SIP devices are used, 39 Ω is the nearest usable equivalent value. The CI± differential inputs are terminated in exactly the same way as the DI± pair.

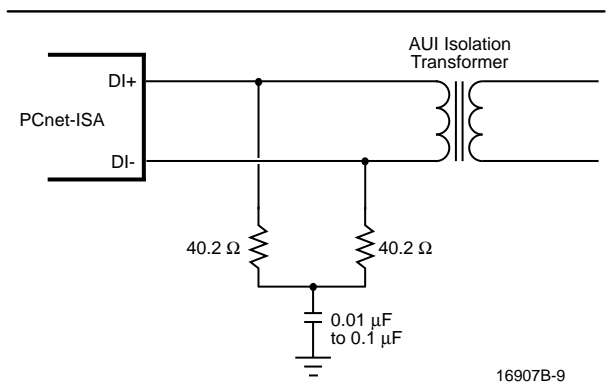

Differential Input Termination

Collision Detection

A MAU detects the collision condition on the network and generates a differential signal at the CI± inputs. This collision signal passes through an input stage which detects signal levels and pulse duration. When the signal is detected by the MENDEC it sets the ICLSN line HIGH. The condition continues for approximately 1.5 bit times after the last LOW-to-HIGH transition on CI±.

Twisted Pair Transceiver (T-MAU)

The T-MAU implements the Medium Attachment Unit (MAU) functions for the Twisted Pair Medium, as specified by the supplement to IEEE 802.3 standard (Type 10BASE-T). The T-MAU provides twisted pair driver and receiver circuits, including on-board transmit digital predistortion and receiver squelch, and a number of additional features including Link Status indication, Automatic Twisted Pair Receive Polarity Detection/Correction and indication, Receive Carrier Sense, Transmit Active and Collision Present indication.

Twisted Pair Transmit Function

The differential driver circuitry in the TXD \pm and TXP \pm pins provides the necessary electrical driving capability and the pre-distortion control for transmitting signals over maximum length Twisted Pair cable, as specified by the 10BASE-T supplement to the IEEE 802.3 Standard. The transmit function for data output meets the propagation delays and jitter specified by the standard.

Twisted Pair Receive Function

The receiver complies with the receiver specifications of the IEEE 802.3 10BASE-T Standard, including noise immunity and received signal rejection criteria ('Smart Squelch'). Signals meeting this criteria appearing at the RXD \pm differential input pair are routed to the MENDEC. The receiver function meets the propagation delays and jitter requirements specified by the standard. The receiver squelch level drops to half its threshold value after unsquelch to allow reception of minimum amplitude signals and to offset carrier fade in the event of worst case signal attenuation conditions.

Note that the 10BASE-T Standard defines the receive input amplitude at the external Media Dependent Interface (MDI). Filter and transformer loss are not specified. The T-MAU receiver squelch levels are designed to account for a 1 dB insertion loss at 10 MHz for the type of receive filters and transformers usually used.

Normal 10BASE-T compatible receive thresholds are invoked when the LRT bit (CSR15, bit 9) is LOW. When the LRT bit is set, the Low Receive Threshold option is invoked, and the sensitivity of the T-MAU receiver is increased. Increasing T-MAU sensitivity allows the use of lines longer than the 100 m target distance of standard 10BASE-T (assuming typical 24 AWG cable). Increased receiver sensitivity compensates for the increased signal attenuation caused by the additional cable distance.

However, making the receiver more sensitive means that it is also more susceptible to extraneous noise, primarily caused by coupling from co-resident services (crosstalk). For this reason, end users may wish to invoke the Low Receive Threshold option on 4-pair cable only. Multi-pair cables within the same outer sheath have lower crosstalk attenuation, and may allow noise emitted from adjacent pairs to couple into the receive pair, and be of sufficient amplitude to falsely unsquelch the T-MAU.

Link Test Function

The link test function is implemented as specified by 10BASE-T standard. During periods of transmit pair inactivity, 'Link beat pulses' will be periodically sent over the twisted pair medium to constantly monitor medium integrity.

When the link test function is enabled (DLNKTST bit in CSR15 is cleared), the absence of link beat pulses and receive data on the RXD \pm pair will cause the TMAU to go into the Link Fail state. In the Link Fail state, data transmission, data reception, data loopback and the collision detection functions are disabled and remain disabled until valid data or greater than 5 consecutive link pulses appear on the RXD \pm pair. During Link Fail, the Link Status (LNKST indicated by LED0) signal is inactive. When the link is identified as functional, the LNKST signal is asserted, and LED0 output will be activated.

In order to inter-operate with systems which do not implement Link Test, this function can be disabled by setting the DLNKTST bit. With Link Test disabled, the Data Driver, Receiver and Loopback functions as well as Collision Detection remain enabled irrespective of the presence or absence of data or link pulses on the RXD \pm pair. Link Test pulses continue to be sent regardless of the state of the DLNKTST bit.

Polarity Detection and Reversal

The T-MAU receive function includes the ability to invert the polarity of the signals appearing at the RXD \pm pair if the polarity of the received signal is reversed (such as in the case of a wiring error). This feature allows data packets received from a reverse wired RXD \pm input pair to be corrected in the T-MAU prior to transfer to the MENDEC. The polarity detection function is activated following reset or Link Fail, and will reverse the receive polarity based on both the polarity of any previous link beat pulses and the polarity of subsequent packets with a valid End Transmit Delimiter (ETD).

When in the Link Fail state, the T-MAU will recognize link beat pulses of either positive or negative polarity. Exit from the Link Fail state occurs at the reception of 5–6 consecutive link beat pulses of identical polarity. On entry to the Link Pass state, the polarity of the last 5 link beat pulses is used to determine the initial receive polarity configuration and the receiver is reconfigured to subsequently recognize only link beat pulses of the previously recognized polarity.

Positive link beat pulses are defined as transmitted signal with a positive amplitude greater than 585 mV (LRT = HIGH) with a pulse width of 60 ns–200 ns. This positive excursion may be followed by a negative excursion. This definition is consistent with the expected received signal at a correctly wired receiver, when a link beat pulse, which fits the template of Figure 14-12 of the 10BASE-T Standard, is generated at a transmitter and passed through 100 m of twisted pair cable.

Negative link beat pulses are defined as transmitted signals with a negative amplitude greater than 585 mV with a pulse width of 60 ns–200 ns. This negative excursion may be followed by a positive excursion. This definition is consistent with the expected received signal at a reverse wired receiver, when a link beat pulse which fits the template of Figure 14–12 in the 10BASE-T Standard is generated at a transmitter and passed through 100 m of twisted pair cable.

The polarity detection/correction algorithm will remain “armed” until two consecutive packets with valid ETD of identical polarity are detected. When “armed,” the receiver is capable of changing the initial or previous polarity configuration according to the detected ETD polarity.

On receipt of the first packet with valid ETD following reset or Link Fail, the T-MAU will use the inferred polarity information to configure its RXD± input, regardless of its previous state. On receipt of a second packet with a valid ETD with correct polarity, the detection/correction algorithm will “lock-in” the received polarity. If the second (or subsequent) packet is not detected as confirming the previous polarity decision, the most recently detected ETD polarity will be used as the default. Note that packets with invalid ETD have no effect on updating the previous polarity decision. Once two consecutive packets with valid ETD have been received, the T-MAU will lock the correction algorithm until either a Link Fail condition occurs or RESET is asserted.

During polarity reversal, an internal POL signal will be active. During normal polarity conditions, this internal POL signal is inactive. The state of this signal can be read by software and/or displayed by LED when enabled by the LED control bits in the ISA Bus Configuration Registers (ISACSR5, 6, 7).

Twisted Pair Interface Status

Three signals (XMT, RCV and COL) indicate whether the T-MAU is transmitting, receiving, or in a collision state. These signals are internal signals and the behavior of the LED outputs depends on how the LED output circuitry is programmed.

The T-MAU will power up in the Link Fail state and the normal algorithm will apply to allow it to enter the Link Pass state. In the Link Pass state, transmit or receive activity will be indicated by assertion of RCV signal going active. If T-MAU is selected using the PORTSEL bits in CSR15 or MAUSEL pin, then when moving from AUI to T-MAU selection the T-MAU will be forced into the Link Fail state.

In the Link Fail state, XMT, RCV and COL are inactive.

Collision Detect Function

Activity on both twisted pair signals RXD± and TXD± constitutes a collision, thereby causing the COL signal to be asserted. (COL is used by the LED control circuits.) The COL will remain asserted until one of the two colliding signals changes from active to idle. During collision condition, data presented on the DI± pair will be sourced from the RXD± input. COL stays active for two bit times at the end of a collision.

Signal Quality Error (SQE) Test (Heartbeat) Function

The SQE function is disabled when the 10BASE-T port is selected and in Link Fail state.

Jabber Function

The Jabber function inhibits the twisted pair transmit function of the T-MAU if the TXD± circuit is active for an excessive period (20–150 ms). This prevents any one node from disrupting the network due to a ‘stuck-on’ or faulty transmitter. If this maximum transmit time is exceeded, the T-MAU transmitter circuitry is disabled, the JAB bit is set (CSR4, bit 1), and COL signal asserted. Once the transmit data stream to the T-MAU is removed, an “unjab” time of 250–750 ms will elapse before the T-MAU deasserts COL and re-enables the transmit circuitry.

Power Down

The T-MAU circuitry can be made to go into low power mode. This feature is useful in battery powered or low duty cycle systems. The T-MAU will go into power down mode when RESET is active, **coma mode** is active, or the T-MAU is not selected. Refer to the Power Down Mode section for a description of the various power down modes.

Any of the three conditions listed above resets the internal logic of the T-MAU and places the device into power down mode. In this mode, the Twisted Pair driver pins (TXD±, TXP±) are asserted LOW, and the internal T-MAU status signals (LNKST, RCVPOL, XMT, RCV and COLLISION) are inactive.

Once the SLEEP pin is deasserted, the T-MAU will be forced into the Link Fail state. The T-MAU will move to the Link Pass state only after 5 - 6 link beat pulses and/or a single received message is detected on the RXD± pair.

In **snooze** mode, the T-MAU receive circuitry will remain enabled even while the SLEEP pin is driven LOW.

The T-MAU circuitry will always go into power down mode if RESET is asserted, **coma mode** is enabled, or the T-MAU is not selected.

EADI (External Address Detection Interface)

This interface is provided to allow external address filtering. It is selected by setting the EADISEL bit in ISACSR2. This feature is typically utilized for terminal servers, bridges and/or router type products. The use of external logic is required to capture the serial bit stream from the PCnet-ISA controller, compare it with a table of stored addresses or identifiers, and perform the desired function.

The EADI interface operates directly from the NRZ decoded data and clock recovered by the Manchester decoder or input to the GPSI, allowing the external address detection to be performed in parallel with frame reception and address comparison in the MAC Station Address Detection (SAD) block.

SRDCLK is provided to allow clocking of the receive bit stream into the external address detection logic. SRDCLK runs only during frame reception activity. Once a received frame commences and data and clock are available, the EADI logic will monitor the alternating ("1,0") preamble pattern until the two ones of the Start Frame Delimiter ("1,0,1,0,1,0,1,1") are detected, at which point the SF/BD output will be driven HIGH.

After SF/BD is asserted the serial data from SRD should be de-serialized and sent to a content addressable memory (CAM) or other address detection device.

To allow simple serial to parallel conversion, SF/BD is provided as a strobe and/or marker to indicate the delineation of bytes, subsequent to the SFD. This provides a mechanism to allow not only capture and/or decoding of the physical or logical (group) address, it also facilitates the capture of header information to determine protocol and or inter-networking information. The $\overline{\text{EAR}}$ pin is driven LOW by the external address comparison logic to reject the frame.

If an internal address match is detected by comparison with either the Physical or Logical Address field, the frame will be accepted regardless of the condition of $\overline{\text{EAR}}$. Incoming frames which do not pass the internal address comparison will continue to be received. This allows approximately 58 byte times after the last destination address bit is available to generate the $\overline{\text{EAR}}$ signal, assuming the device is not configured to accept runt packets. $\overline{\text{EAR}}$ will be ignored after 64 byte times after the SFD, and the frame will be accepted if $\overline{\text{EAR}}$ has not been asserted before this time. If Runt Packet Accept is configured, the $\overline{\text{EAR}}$ signal must be generated prior to the receive message completion, which could be as short as 12 byte times (assuming 6 bytes for source address, 2 bytes for length, no data, 4 bytes for FCS) after the last bit of the destination address is available. $\overline{\text{EAR}}$ must have a pulse width of at least 200 ns.

Note that setting the PROM bit (CSR15, bit 15) will cause all receive frames to be received, regardless of the state of the $\overline{\text{EAR}}$ input.

If the DRCVPA bit (CSR15.13) is set and the logical address (LADRF) is set to zero, only frames which are not rejected by $\overline{\text{EAR}}$ will be received.

The EADI interface will operate as long as the STRT bit in CSR0 is set, even if the receiver and/or transmitter are disabled by software (DTX and DRX bits in CSR15 set). This situation is useful as a power down mode in that the PCnet-ISA controller will not perform any DMA operations; this saves power by not utilizing the ISA bus driver circuits. However, external circuitry could still respond to specific frames on the network to facilitate remote node control.

The table below summarizes the operation of the EADI features.

Table: Internal/External Address Recognition Capabilities

PROM	$\overline{\text{EAR}}$	Required Timing	Received Messages
1	X	No timing requirements	All Received Frames
0	1	No timing requirements	All Received Frames
0	0	Low for 200 ns within 512 bits after SFD	Physical/Logical Matches

General Purpose Serial Interface (GPSI)

The PCnet-ISA controller contains a General Purpose Serial Interface (GPSI) designed for testing the digital portions of the chip. The MENDEC, AUI, and twisted pair interface are by-passed once the device is set up in the special "test mode" for accessing the GPSI functions. Although this access is intended only for testing the device, some users may find the non-encoded data functions useful in some special applications. Note, however, that the GPSI functions can be accessed only when the PCnet-ISA devices operate as a bus master.

The PCnet-ISA GPSI signals are consistent with the LANCE digital serial interface. Since the GPSI functions can be accessed only through a special test mode, expect some loss of functionality to the device when the GPSI is invoked. The AUI and 10BASE-T analog interfaces are disabled along with the internal MENDEC logic. The LA (unlatched address) pins are removed and become the GPSI signals, therefore, only 20 bits of address space is available. The table below shows the GPSI pin configuration:

To invoke the GPSI signals, follow the procedure below:

1. After reset or I/O read of Reset Address, write 10b to PORTSEL bits in CSR15.
2. Set the ENTST bit in CSR4
3. Set the GPSIEN bit in CSR124 (see note below)
(The pins LA17–LA23 will change function after the completion of the above three steps.)
4. Clear the ENTST bit in CSR4
5. Clear both media select bits in ISACSR2
6. Define the PORTSEL bits in the MODE register (CSR15) to be 10b to define GPSI port. The MODE register image is in the initialization block.

Note: LA pins will be tristated before writing to CORETST bit. After writing to GPSIEN, LA[17–21] will be inputs, LA[22–23] will be outputs.

Table: GPSI Pin Configurations

GPSI Function	GPSI I/O Type	LANCE/ C-LANCE GPSI Pin	PCnet-ISA GPSI Pin Function	PCnet-ISA Pin Number	PCnet-ISA Normal Pin Function
Receive Data	I	RX	RXDAT	5	LA17
Receive Clock	I	RCLK	SRDCLK	6	LA18
Receive Carrier Sense	I	RENA	RXCRES	7	LA19
Collision	I	CLSN	CLSN	9	LA20
Transmit Clock	I	TCLK	STDCLK	10	LA21
Transmit Enable	O	TENA	TXEN	11	LA22
Transmit Data	O	TX	TXDAT	12	LA23

Note: The GPSI function is only available in the Bus Master mode of operation.

IEEE 1149.1 Test Access Port Interface

An IEEE 1149.1 compatible boundary scan Test Access Port is provided for board-level continuity test and diagnostics. All digital input, output, and input/output pins are tested. Analog pins, including the AUI differential driver (DO \pm) and receivers (DI \pm , CI \pm), and the crystal input (XTAL1/XTAL2) pins, are tested. The T-MAU drivers TXD \pm , TXP \pm , and receiver RXD \pm are also tested.

The following is a brief summary of the IEEE 1149.1 compatible test functions implemented in the PCnet-ISA controller.

Boundary Scan Circuit

The boundary scan test circuit requires four extra pins (TCK, TMS, TDI and TDO), defined as the Test Access Port (TAP). It includes a finite state machine (FSM), an instruction register, a data register array, and a power-on reset circuit. Internal pull-up resistors are provided for the TDI, TCK, and TMS pins. The TCK pin must not be left unconnected. The boundary scan circuit remains active during sleep.

TAP FSM

The TAP engine is a 16-state FSM, driven by the Test Clock (TCK) and the Test Mode Select (TMS) pins. This FSM is in its reset state at power-up or RESET. An independent power-on reset circuit is provided to ensure the FSM is in the TEST_LOGIC_RESET state at power-up.

Supported Instructions

In addition to the minimum IEEE 1149.1 requirements (BYPASS, EXTEST and SAMPLE instructions), three additional instructions (IDCODE, TRIBYP and SETBYP) are provided to further ease board-level testing.

All unused instruction codes are reserved. See the table below for a summary of supported instructions.

Instruction Register and Decoding Logic

After hardware or software RESET, the IDCODE instruction is always invoked. The decoding logic gives signals to control the data flow in the DATA registers according to the current instruction.

Boundary Scan Register (BSR)

Each BSR cell has two stages. A flip-flop and a latch are used in the SERIAL SHIFT STAGE and the PARALLEL OUTPUT STAGE, respectively.

There are four possible operational modes in the BSR cell:

1	Capture
2	Shift
3	Update
4	System Function

Other Data Registers

(1) BYPASS REG (1 BIT)

(2) DEV ID REG (32 bits)

Bits 31–28:	Version
Bits 27–12:	Part number (0003H)
Bits 11–1:	Manufacturer ID. The 11 bit manufacturer ID code for AMD is 0000000001 according to JEDEC Publication 106-A.
Bit 0:	Always a logic 1

Table: IEEE 1149.1 Supported Instruction Summary

Instruction Name	Description	Selected Data Reg	Mode	Instruction Code
EXTEST	External Test	BSR	Test	0000
IDCODE	ID Code Inspection	ID REG	Normal	0001
SAMPLE	Sample Boundary	BSR	Normal	0010
TRIBYP	Force Tristate	Bypass	Normal	0011
SETBYP	Control Boundary To 1/0	Bypass	Test	0100
BYPASS	Bypass Scan	Bypass	Normal	1111

Power Savings Modes

The PCnet-ISA controller supports two hardware power-savings modes. Both are entered by asserting the SLEEP pin LOW.

In **coma** mode, the PCnet-ISA controller will go into deep sleep with no support to automatically wake itself up. Coma mode is enabled when the AWAKE bit in ISACSR2 is reset. This mode is the default power down mode.

In **snooze** mode, enabled by setting the AWAKE bit in ISACSR2 and driving the SLEEP pin LOW, the T-MAU receive circuitry will remain enabled even while the SLEEP pin is driven LOW. The LED0 output will also continue to function, indicating a good 10BASE-T link if there are link beat pulses or valid frames present. This LED0 pin can be used to drive a LED and/or external hardware that directly controls the SLEEP pin of the PCnet-ISA controller. This configuration effectively wakes the system when there is any activity on the 10BASE-T link.

Access Operations (Software)

We begin by describing how byte and word data are addressed on the ISA bus, including conversion cycles where 16-bit accesses are turned into 8-bit accesses because the resource accessed did not support 16-bit operations. Then we describe how registers and other resources are accessed. This section is for the device programmer, while the next section (bus cycles) is for the hardware designer.

I/O Resources

The PCnet-ISA controller has both I/O and memory resources. In the I/O space the resources are organized as indicated in the following table:

Offset	#Bytes	Register
0h	16	IEEE Address PROM
10h	2	RDP
12h	2	RAP (shared by RDP and IDP)
14h	2	Reset
16h	2	IDP

The PCnet-ISA controller does not respond to any addresses outside of the offset range 0-17h. I/O offsets 18h and up are not used by the PCnet-ISA controller.

I/O Register Access

The register address port (RAP) is shared by the register data port (RDP) and the ISACSR data port (IDP) to save registers. To access the Ethernet controller's RDP or IDP, the RAP should be written first, followed by the read or write access to the RDP or IDP. I/O register accesses should be coded as 16-bit accesses, even if the PCnet-ISA controller is hardware configured for 8-bit I/O bus cycles. It is acceptable (and transparent) for the motherboard to turn a 16-bit software access into two

separate 8-bit hardware bus cycles. The motherboard accesses the low byte before the high byte and the PCnet-ISA controller has circuitry to specifically support this type of access.

The reset register causes a reset when read. Any value will be accepted and the cycle may be 8 or 16 bits wide. Writes are ignored.

All PCnet-ISA controller register accesses should be coded as 16-bit operations.

**Note that the RAP is cleared on Reset.*

Address PROM Access

The address PROM is an external memory device that contains the node's unique physical Ethernet address and any other data stored by the board manufacturer. The software accesses may be 8- or 16-bit.

Boot PROM Access

The boot PROM is an external memory resource located at the address selected by the IOAM0 and IOAM1 pins in bus master mode, or the BPAM input in shared memory mode. It may be software accessed as an 8- or 16-bit resource but the latter is recommended for best performance.

Static RAM Access

The static RAM is only present in the shared memory mode. It is located at the address selected by the SMAM input. It may be accessed as an 8- or 16-bit resource but the latter is recommended for best performance.

Bus Cycles (Hardware)

The PCnet-ISA controller supports both 8- and 16-bit hardware bus cycles. The following sections outline where any limitations apply based upon the architecture mode and/or the resource that is being accessed (PCnet-ISA controller registers, address PROM, boot PROM, or shared memory SRAM). For completeness, the following sections are arranged by architecture (Bus Master Mode or Shared Memory Mode). SRAM resources apply only to Shared Memory Mode.

All resources (registers, PROMs, SRAM) are presented to the ISA bus by the PCnet-ISA controller. With few exceptions, these resources can be configured for either 8-bit or 16-bit bus cycles. The I/O resources (registers, address PROM) are width configured using the IOCS16 pin on the PCnet-ISA controller. The memory resources (boot PROM, SRAM) are width configured by external hardware.

For 16-bit memory accesses, hardware external to the PCnet-ISA controller asserts MEMCS16 when either of the two memory resources is selected. The ISA bus requires that all memory resources within a block of 128 Kbytes be the same width, either 8- or 16-bits. The reason for this is that the MEMCS16 signal is generally a decode of the LA17-23 address lines. 16-bit memory

capability is desirable since two 8-bit accesses take the same amount of time as four 16-bit accesses.

All accesses to 8-bit resources (which do not return $\overline{\text{MEMCS16}}$ or $\overline{\text{IOCS16}}$) use SD0-7. If an odd byte is accessed, the Current Master swap buffer turns on. During an odd byte read the swap buffer copies the data from SD0-7 to the high byte. During an odd byte write the Current Master swap buffer copies the data from the high byte to SD0-7. The PCnet-ISA controller can be configured to be an 8-bit I/O resource even in a 16-bit system; this is accomplished by disconnecting $\overline{\text{IOCS16}}$ from the ISA bus and tying $\overline{\text{IOCS16}}$ to ground. It is recommended that the PCnet-ISA controller be hardware configured for 8-bit only I/O bus cycles for maximum compatibility with PC/AT clone motherboards.

When the PCnet-ISA controller is in an 8-bit system such as a PC/XT, $\overline{\text{SBHE}}$ and $\overline{\text{IOCS16}}$ must be left unconnected (these signals do not exist in the PC/XT). This will force ALL resources (I/O and memory) to support only 8-bit bus cycles. The PCnet-ISA controller will function in an 8-bit system only if configured for Shared Memory Mode.

Accesses to 16-bit resources (which do return $\overline{\text{MEMCS16}}$ or $\overline{\text{IOCS16}}$) use either or both SD0-7 and SD8-15. A word access is indicated by A0=0 and $\overline{\text{SBHE}}=0$ and data is transferred on all 16 data lines. An even byte access is indicated by A0=0 and $\overline{\text{SBHE}}=1$ and

data is transferred on SD0-7. An odd-byte access is indicated by A0=1 and $\overline{\text{SBHE}}=0$ and data is transferred on SD8-15. It is illegal to have A0=1 and $\overline{\text{SBHE}}=1$ in any bus cycle. The PCnet-ISA controller returns only $\overline{\text{IOCS16}}$; $\overline{\text{MEMCS16}}$ must be generated by external hardware if desired. The use of $\overline{\text{MEMCS16}}$ applies only to Shared Memory Mode.

The following table describes all possible types of ISA bus accesses, including Permanent Master as Current Master and PCnet-ISA controller as Current Master. The PCnet-ISA controller will not work with 8-bit memory while it is Current Master. Any descriptions of 8-bit memory accesses are for when the Permanent Master is Current Master.

The two byte columns (D0-7 and D8-15) indicate whether the bus master or slave is driving the byte. $\overline{\text{CS16}}$ is a shorthand for $\overline{\text{MEMCS16}}$ and $\overline{\text{IOCS16}}$.

Bus Master Mode

The PCnet-ISA controller can be configured as a Bus Master only in systems that support bus mastering. In addition, the system is assumed to support 16-bit memory (DMA) cycles (the PCnet-ISA controller does not use the $\overline{\text{MEMCS16}}$ signal on the ISA bus). This does not preclude the PCnet-ISA controller from doing 8-bit I/O transfers. The PCnet-ISA controller will not function as a bus master in 8-bit platforms such as the PC/XT.

Table: ISA Bus Accesses

R/W	A0	$\overline{\text{SBHE}}$	$\overline{\text{CS16}}$	D0-7	D8-15	Comments
RD	0	1	x	Slave	Float	Low byte RD
RD	1	0	1	Slave	Float*	High byte RD with swap
RD	0	0	1	Slave	Float	16-Bit RD converted to low byte RD
RD	1	0	0	Float	Slave	High byte RD
RD	0	0	0	Slave	Slave	16-Bit RD
WR	0	1	x	Master	Float	Low byte WR
WR	1	0	1	Float*	Master	High byte WR with swap
WR	0	0	1	Master	Master	16-Bit WR converted to low byte WR
WR	1	0	0	Float	Master	High byte WR
WR	0	0	0	Master	Master	16-Bit WR

*Motherboard SWAP logic drives

Refresh Cycles

Although the PCnet-ISA controller is neither an originator or a receiver of refresh cycles, it does need to avoid unintentional activity during a refresh cycle in bus master mode. A refresh cycle is performed as follows: First, the $\overline{\text{REF}}$ signal goes active. Then a valid refresh address is placed on the address bus. $\overline{\text{MEMR}}$ goes active, the refresh is performed, and $\overline{\text{MEMR}}$ goes inactive. The refresh address is held for a short time and then goes invalid. Finally, $\overline{\text{REF}}$ goes inactive. During a refresh cycle, as indicated by $\overline{\text{REF}}$ being active, the PCnet-ISA controller inhibits its $\overline{\text{SMEMR}}$ inputs and ignores $\overline{\text{DACK}}$ if it goes active until it goes inactive. It is necessary to ignore $\overline{\text{DACK}}$ during a refresh because some motherboards generate a false $\overline{\text{DACK}}$ at that time.

Address PROM Cycles

The Address PROM is a small (16 bytes) 8-bit PROM connected to the PCnet-ISA controller Private Data Bus. The PCnet-ISA controller will support only 8-bit ISA I/O bus cycles for the address PROM; this limitation is transparent to software and does not preclude 16-bit software I/O accesses. An access cycle begins with the Permanent Master driving $\overline{\text{AEN}}$ LOW, driving the addresses valid, and driving $\overline{\text{IOR}}$ active. The PCnet-ISA controller detects this combination of signals and arbitrates for the Private Data Bus (PRDB) if necessary. $\overline{\text{IOCHRDY}}$ is driven LOW during accesses to the address PROM.

When the Private Data Bus becomes available, the PCnet-ISA controller drives $\overline{\text{APCS}}$ active, releases $\overline{\text{IOCHRDY}}$, turns on the data path from PRD0-7, and enables the SD0-7 drivers (but not SD8-15). During this bus cycle, $\overline{\text{IOCS16}}$ is not driven active. This condition is maintained until $\overline{\text{IOR}}$ goes inactive, at which time the bus cycle ends. Data is removed from SD0-7 within 30 ns.

Ethernet Controller Register Cycles

Ethernet controller registers (RAP, RDP, IDP) are naturally 16-bit resources but can be configured to operate with 8-bit bus cycles provided the proper protocol is followed. If $\overline{\text{IOCS16}}$ has never gone HIGH since RESET, then all controller register bus cycles will be 8-bit only. This situation would occur if the $\overline{\text{IOCS16}}$ pin is left unconnected to the ISA bus and tied to ground. This means on a read, the PCnet-ISA controller will only drive the low byte of the system data bus; if an odd byte is accessed, it will be swapped down. The high byte of the system data bus is never driven by the PCnet-ISA controller under these conditions. On a write cycle, the even byte is placed in a holding register. An odd byte write is internally swapped up and augmented with the even byte in the holding register to provide an internal 16-bit write. This allows the use of 8-bit I/O bus cycles which are more likely to be compatible with all ISA-compatible clones, but requires that both bytes be written in immediate succession. This is accomplished simply by treating the PCnet-ISA controller registers as 16-bit software resources. The motherboard will convert the 16-bit accesses done by software into two sequential

8-bit accesses, an even byte access followed immediately by an odd byte access.

An access cycle begins with the Permanent Master driving $\overline{\text{AEN}}$ LOW, driving the address valid, and driving $\overline{\text{IOR}}$ or $\overline{\text{IOW}}$ active. The PCnet-ISA controller detects this combination of signals and drives $\overline{\text{IOCHRDY}}$ LOW. $\overline{\text{IOCS16}}$ will also be driven LOW if 16-bit I/O bus cycles are enabled. When the register data is ready, $\overline{\text{IOCHRDY}}$ will be released HIGH. This condition is maintained until $\overline{\text{IOR}}$ or $\overline{\text{IOW}}$ goes inactive, at which time the bus cycle ends.

RESET Cycles

A read to the reset address causes an PCnet-ISA controller reset. This has the same effect as asserting the RESET pin on the PCnet-ISA controller, such as happens during a system power-up or hard boot. The subsequent write cycle needed in the NE2100 LANCE based family of Ethernet cards is not required but does not have any harmful effects. $\overline{\text{IOCS16}}$ is not asserted in this cycle.

ISA Configuration Register Cycles

The ISA configuration registers are accessed by placing the address of the desired register into the RAP and reading the IDP. The ISACSR bus cycles are identical to all other PCnet-ISA controller register bus cycles.

Boot PROM Cycles

The Boot PROM is an 8-bit PROM connected to the PCnet-ISA controller Private Data Bus (PRDB) and can occupy up to 16 Kbytes of address space. Since the PCnet-ISA controller does not generate $\overline{\text{MEMCS16}}$, only 8-bit ISA memory bus cycles to the boot PROM are supported in Bus Master Mode; this limitation is transparent to software and does not preclude 16-bit software memory accesses. A boot PROM access cycle begins with the Permanent Master driving the addresses valid, $\overline{\text{REF}}$ inactive, and $\overline{\text{SMEMR}}$ active. ($\overline{\text{AEN}}$ is not involved in memory cycles). The PCnet-ISA controller detects this combination of signals, drives $\overline{\text{IOCHRDY}}$ LOW, and reads a byte out of the Boot PROM. The data byte read is driven onto the lower system data bus lines and $\overline{\text{IOCHRDY}}$ is released. This condition is maintained until $\overline{\text{SMEMR}}$ goes inactive, at which time the access cycle ends.

The $\overline{\text{BPCS}}$ signal generated by the PCnet-ISA controller is three 20 MHz clock cycles wide (150 ns). Including delays, the Boot PROM has 120 ns to respond to the $\overline{\text{BPCS}}$ signal from the PCnet-ISA controller. This signal is intended to be connected to the $\overline{\text{CS}}$ pin on the boot

PROM, with the PROM $\overline{\text{OE}}$ pin tied to ground. When using a PROM with an access time slower than 120 ns, $\overline{\text{BPCS}}$ may be connected to the $\overline{\text{OE}}$ pin of the boot PROM while tying the PROM $\overline{\text{CS}}$ pin to ground.

Current Master Operation

Current Master operation only occurs in the bus master mode. It does not occur in shared memory mode.

There are three phases to the use of the bus by the PCnet-ISA controller as Current Master, the Obtain Phase, the Access Phase, and the Release Phase.

Obtain Phase

A Master Mode Transfer Cycle begins by asserting DRQ. When the Permanent Master asserts DACK, the PCnet-ISA controller asserts MASTER, signifying it has taken control of the ISA bus. The Permanent Master tristates the address, command, and data lines within 60 ns of DACK going active. The Permanent Master drives AEN inactive within 71 ns of MASTER going active.

Access Phase

The ISA bus requires a wait of at least 125 ns after MASTER is asserted before the new master is allowed to drive the address, command, and data lines. The PCnet-ISA controller will actually wait 3 clock cycles or 150 ns.

The following signals are not driven by the Permanent Master and are simply pulled HIGH: BALE, IOCHRDY, IOCS16, MEMCS16, SRDY. Therefore, the PCnet-ISA controller assumes the memory which it is accessing is 16 bits wide and can complete an access in the time programmed for the PCnet-ISA controller MEMR and MEMW signals. Refer to the ISA Bus Configuration Register description section.

Release Phase

When the PCnet-ISA controller is finished with the bus, it drives the command lines inactive. 50 ns later, the controller tri-states the command, address, and data lines and drives DRQ inactive. 50 ns later, the controller drives MASTER inactive.

At least 375 ns after DRQ goes inactive, the Permanent Master drives DACK inactive.

The Permanent Master drives AEN active within 71 ns of MASTER going inactive. The Permanent Master is allowed to drive the command lines no sooner than 60 ns after DACK goes inactive.

Master Mode Memory Read Cycle

After the PCnet-ISA controller has acquired the ISA bus, it can perform a memory read cycle. All timing is generated relative to the 20 MHz clock (network clock). Since there is no way to tell if memory is 8- or 16-bit or when it is ready, the PCnet-ISA controller by default assumes 16-bit, 1 wait state memory. The wait state assumption is based on the default value in the MSRDA register in ISACSR0.

The cycle begins with SA0-19, SBHE, and LA17-23 being presented. The ISA bus requires them to be valid for at least 28 ns before a read command and the

PCnet-ISA controller provides one clock or 50 ns of setup time before asserting MEMR.

The ISA bus requires MEMR to be active for at least 219 ns, and the PCnet-ISA controller provides a default of 5 clocks, or 250 ns, but this can be tuned for faster systems with the Master Mode Read Active (MSRDA) register (see section 2.5.2). Also, if IOCHRDY is driven LOW, the PCnet-ISA controller will wait. The wait state counter must expire and IOCHRDY must be HIGH for the PCnet-ISA controller to continue.

The PCnet-ISA controller then accepts the memory read data. The ISA bus requires all command lines to remain inactive for at least 97 ns before starting another bus cycle and the PCnet-ISA controller provides at least two clocks or 100 ns of inactive time.

The ISA bus requires read data to be valid no more than 173 ns after receiving MEMR active and the PCnet-ISA controller requires 10 ns of data setup time. The ISA bus requires read data to provide at least 0 ns of hold time and to be removed from the bus within 30 ns after MEMR goes inactive. The PCnet-ISA controller requires 0 ns of data hold time.

Master Mode Memory Write Cycle

After the PCnet-ISA controller has acquired the ISA bus, it can perform a memory write cycle. All timing is generated relative to a 20 MHz clock which happens to be the same as the network clock. Since there is no way to tell if memory is 8- or 16-bit or when it is ready, the PCnet-ISA controller by default assumes 16-bit, 1 wait state memory. The wait state assumption is based on the default value in the MSWRA register in ISACSR1.

The cycle begins with SA0-19, SBHE, and LA17-23 being presented. The ISA bus requires them to be valid at least 28 ns before MEMW goes active and data to be valid at least 22 ns before MEMW goes active. The PCnet-ISA controller provides one clock or 50 ns of setup time for all these signals.

The ISA bus requires MEMW to be active for at least 219 ns, and the PCnet-ISA controller provides a default of 5 clocks, or 250 ns, but this can be tuned for faster systems with the Master Mode Write Active (MSWRA) register (ISACSR1). Also, if IOCHRDY is driven LOW, the PCnet-ISA controller will wait. IOCHRDY must be HIGH for the PCnet-ISA controller to continue.

The ISA bus requires data to be valid for at least 25 ns after MEMW goes inactive, and the PCnet-ISA controller provides one clock or 50 ns.

The ISA bus requires all command lines to remain inactive for at least 97 ns before starting another bus cycle. The PCnet-ISA controller provides at least two clocks or 100 ns of inactive time when bit 4 in ISACSR2 is set. The EISA bus requires all command lines to remain inactive for at least 170 ns before starting another bus cycle. When bit 4 in ISACSR4 is cleared, the PCnet-ISA controller provides 200 ns of inactive time.

Shared Memory Mode

Address PROM Cycles

The Address PROM is a small (16 bytes) 8-bit PROM connected to the PCnet-ISA controller Private Data Bus (PRDB). The PCnet-ISA controller will support only 8-bit ISA I/O bus cycles for the address PROM; this limitation is transparent to software and does not preclude 16-bit software I/O accesses. An access cycle begins with the Permanent Master driving $\overline{\text{AEN}}$ LOW, driving the addresses valid, and driving $\overline{\text{IOR}}$ active. The PCnet-ISA controller detects this combination of signals and arbitrates for the Private Data Bus if necessary. IOCHRDY is always driven LOW during address PROM accesses.

When the Private Data Bus becomes available, the PCnet-ISA controller drives $\overline{\text{APCS}}$ active, releases IOCHRDY , turns on the data path from PRD0-7, and enables the SD0-7 drivers (but not SD8-15). During this bus cycle, $\overline{\text{IOCS16}}$ is not driven active. This condition is maintained until $\overline{\text{IOR}}$ goes inactive, at which time the access cycle ends. Data is removed from SD0-7 within 30 ns.

The PCnet-ISA controller will perform 8-bit ISA bus cycle operation for all resources (registers, PROMs, SRAM) if $\overline{\text{SBHE}}$ has been left unconnected, such as in the case of an 8-bit system like the PC/XT.

Ethernet Controller Register Cycles

Ethernet controller registers (RAP, RDP, ISACSR) are naturally 16-bit resources but can be configured to operate with 8-bit bus cycles provided the proper protocol is followed. If $\overline{\text{IOCS16}}$ has never gone HIGH since RESET, then all controller register bus cycles will be 8-bit only. This situation would occur if the $\overline{\text{IOCS16}}$ pin is disconnected from the ISA bus and tied to ground. This means on a read, the PCnet-ISA controller will only drive the low byte of the system data bus; if an odd byte is accessed, it will be swapped down. The high byte of the system data bus is never driven by the PCnet-ISA controller under these conditions. On a write, the even byte is placed in a holding register. An odd-byte write is internally swapped up and augmented with the even byte in the holding register to provide an internal 16-bit write. This allows the use of 8-bit I/O bus cycles which are more likely to be compatible with all clones, but requires that both bytes be written in immediate succession. This is accomplished simply by treating the PCnet-ISA controller controller registers as 16-bit software resources. The motherboard will convert the 16-bit accesses done by software into two sequential 8-bit accesses, an even-byte access followed immediately by an odd-byte access.

An access cycle begins with the Permanent Master driving $\overline{\text{AEN}}$ LOW, driving the address valid, and driving $\overline{\text{IOR}}$ or $\overline{\text{IOW}}$ active. The PCnet-ISA controller detects this combination of signals and drives IOCHRDY LOW. $\overline{\text{IOCS16}}$ will also be driven LOW if 16-bit I/O bus cycles are enabled. When the register data is ready, IOCHRDY will be released HIGH. This condition is maintained until

$\overline{\text{IOR}}$ or $\overline{\text{IOW}}$ goes inactive, at which time the bus cycle ends.

The PCnet-ISA controller will perform 8-bit ISA bus cycle operation for all resources (registers, PROMs, SRAM) if $\overline{\text{SBHE}}$ has been left unconnected, such as in the case of an 8-bit system like the PC/XT.

RESET Cycles

A read to the reset address causes an PCnet-ISA controller reset. This has the same effect as asserting the RESET pin on the PCnet-ISA controller, such as happens during a system power-up or hard boot. The subsequent write cycle needed in the NE2100 LANCE-based family of Ethernet cards is not required but does not have any harmful effects. $\overline{\text{IOCS16}}$ is not asserted in this cycle.

ISA Configuration Register Cycles

The ISA configuration register is accessed by placing the address of the desired register into the RAP and reading the IDP. The ISACSR bus cycles are identical to all other PCnet-ISA controller register bus cycles.

Boot PROM Cycles

The Boot PROM is an 8-bit PROM connected to the PCnet-ISA controller Private Data Bus (PRDB), and can occupy up to 64 Kbytes of address space. In Shared Memory Mode, an external address comparator is responsible for asserting $\overline{\text{BPAM}}$ to the PCnet-ISA controller. $\overline{\text{BPAM}}$ is intended to be a perfect decode of the boot PROM address space, i.e. REF, LA17-23, SA14-16 for a 16 Kbyte PROM. The LA bus must be latched with BALE in order to provide stable signal for $\overline{\text{BPAM}}$. $\overline{\text{REF}}$ inactive must be used by the external logic to gate boot PROM address decoding. This same logic must assert $\overline{\text{MEMCS16}}$ to the ISA bus if 16-bit Boot PROM bus cycles are desired.

The PCnet-ISA controller assumes 16-bit ISA memory bus cycles for the boot PROM. A 16-bit boot PROM bus cycle begins with the Permanent Master driving the addresses valid, $\overline{\text{REF}}$ inactive, and $\overline{\text{SMEMR}}$ active. ($\overline{\text{AEN}}$ is not involved in memory cycles). External hardware would assert $\overline{\text{BPAM}}$ and $\overline{\text{MEMCS16}}$. The PCnet-ISA controller detects this combination of signals, drives IOCHRDY LOW, and reads two bytes out of the boot PROM. The data bytes read from the PROM are driven by the PCnet-ISA controller onto SD0-15 and IOCHRDY is released. This condition is maintained until $\overline{\text{MEMR}}$ goes inactive, at which time the access cycle ends.

The PCnet-ISA controller can be made to support only 8-bit ISA memory bus cycles for the boot PROM. This can be accomplished by asserting $\overline{\text{BPAM}}$ and $\overline{\text{SMAM}}$ simultaneously; the PCnet-ISA controller would respond using 8-bit ISA memory bus cycles only. Since this is an illegal situation for simple address decoders, the external address decoder must artificially drive $\overline{\text{SMAM}}$ LOW when the (8-bit) boot PROM address space is being accessed. In this case, $\overline{\text{MEMCS16}}$ must not be asserted.

The PCnet-ISA controller will perform 8-bit ISA bus cycle operation for all resource (registers, PROMs, SRAM) if \overline{SBHE} has been left unconnected, such as in the case of an 8-bit system like the PC/XT.

The \overline{BPCS} signal generated by the PCnet-ISA controller is three 20 MHz clock cycles wide (150 ns). Including delays, the Boot PROM has 120 ns to respond to the \overline{BPCS} signal from the PCnet-ISA controller. This signal is intended to be connected to the \overline{CS} pin on the boot PROM, with the PROM \overline{OE} pin tied to ground. The access time of the boot PROM must be 120 ns or faster when 16-bit ISA memory cycles are to be supported.

Static RAM Cycles

The shared memory SRAM is an 8-bit device connected to the PCnet-ISA controller Private Bus, and can occupy up to 64 Kbytes of address space. In Shared Memory Mode, an external address comparator is responsible for asserting \overline{SMAM} to the PCnet-ISA controller. \overline{SMAM} is intended to be a perfect decode of the SRAM address space, i.e. \overline{REF} , LA17-23, SA16 for 64 Kbytes of SRAM. The LA signals must be latched by \overline{BALE} in order to provide a stable decode for \overline{SMAM} . The PCnet-ISA controller assumes 16-bit ISA memory bus cycles for the SRAM, so this same logic must assert $\overline{MEMCS16}$ to the ISA bus if 16-bit bus cycles are to be supported.

A 16-bit SRAM bus cycle begins with the Permanent Master driving the addresses valid, \overline{REF} inactive, and either \overline{MEMR} or \overline{MEMW} active. (AEN is not involved in memory cycles). External hardware would assert \overline{SMAM} and $\overline{MEMCS16}$. The PCnet-ISA controller detects this combination of signals and initiates the SRAM access.

In a write cycle, the PCnet-ISA controller stores the data into an internal holding register, allowing the ISA bus cycle to finish normally. The data in the holding register will then be written to the SRAM without the need for ISA bus control. In the event the holding register is already filled with unwritten SRAM data, the PCnet-ISA controller will extend the ISA write cycle by driving $\overline{IOCHRDY}$ LOW until the unwritten data is stored in the SRAM. The current ISA bus cycle will then complete normally.

In a read cycle, the PCnet-ISA controller arbitrates for the Private Bus. If it is unavailable, the PCnet-ISA controller drives $\overline{IOCHRDY}$ LOW. When the Private Data Bus is available, the PCnet-ISA controller asserts the

Address Buffer Output Enable (\overline{ABOE}) signal to drive the upper 6 bits of the Private Address Bus from the System Address Bus. The PCnet-ISA controller itself drives the lower 10 bits of the Private Address Bus from the System Address Bus and compares the 16 bits of address on the Private Address Bus with that of a SRAM data word held in an internal pre-fetch buffer.

If the address does not match that of the prefetched SRAM data, then the PCnet-ISA controller drives $\overline{IOCHRDY}$ LOW and reads two bytes from the SRAM. The PCnet-ISA controller then proceeds as though the addressed data location had been prefetched.

If the internal prefetch buffer contains the correct data, then the pre-fetch buffer data is driven on the System Data bus. If $\overline{IOCHRDY}$ was previously driven LOW due to either Private Data Bus arbitration or SRAM access, then it is released HIGH. The PCnet-ISA controller remains in this state until \overline{MEMR} is de-asserted, at which time the PCnet-ISA controller performs a new prefetch of the SRAM. In this way memory read wait states can be minimized.

The PCnet-ISA controller performs prefetches of the SRAM between ISA bus cycles. The SRAM is prefetched in an incrementing word address fashion. Prefetched data are invalidated by any other activity on the Private Bus, including Shared Memory Writes by either the ISA bus or the network interface, and also address and boot PROM reads.

The only way to configure the PCnet-ISA controller for 8-bit ISA bus cycles for SRAM accesses is to configure the entire PCnet-ISA controller to support only 8-bit ISA bus cycles. This is accomplished by leaving the \overline{SBHE} pin disconnected. The PCnet-ISA controller will perform 8-bit ISA bus cycle operation for all resources (registers, PROMs, SRAM) if \overline{SBHE} has never been driven active since the last RESET, such as in the case of an 8-bit system like the PC/XT. In this case, the external address decode logic must not assert $\overline{MEMCS16}$ to the ISA bus, which will be the case if $\overline{MEMCS16}$ is left unconnected. It is possible to manufacture a dual 8/16 bit PCnet-ISA controller adapter card, as the $\overline{MEMCS16}$ and \overline{SBHE} signals do not exist in the PC/XT environment.

At the memory device level, each SRAM Private Bus read cycle takes two 50 ns clock periods for a maximum read access time of 75 ns. The timing looks like this:

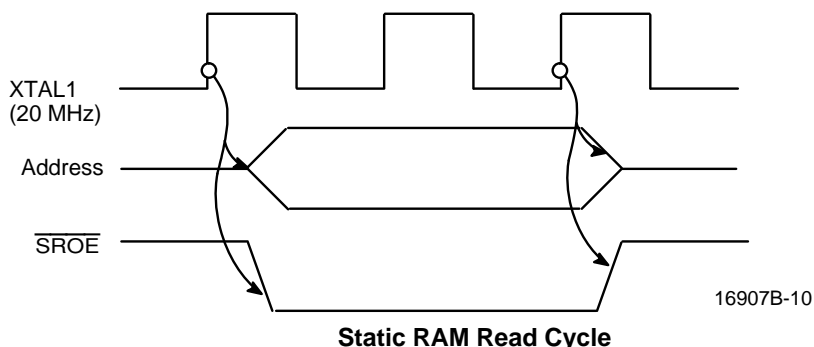

The address and $\overline{\text{SROE}}$ go active within 20 ns of the clock going HIGH. Data is required to be valid 5 ns before the end of the second clock cycle. Address and $\overline{\text{SROE}}$ have a 0 ns hold time after the end of the second clock cycle. Note that the PCnet-ISA controller does not provide a separate SRAM $\overline{\text{CS}}$ signal; SRAM $\overline{\text{CS}}$ must always be asserted.

SRAM Private Bus write cycles require three 50 ns clock periods to guarantee non-negative address setup and hold times with regard to $\overline{\text{SRWE}}$. The timing is illustrated as follows:

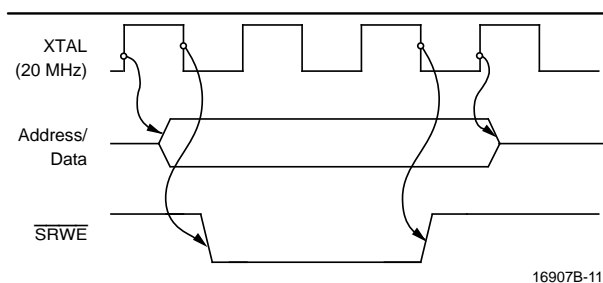

Static RAM Write Cycle

Address and data are valid 20 ns after the rising edge of the first clock period. $\overline{\text{SRWE}}$ goes active 20 ns after the falling edge of the first clock period. $\overline{\text{SRWE}}$ goes inactive 20 ns after the falling edge of the third clock period. Address and data remain valid until the end of the third clock period. Rise and fall times are nominally 5 ns. Non-negative setup and hold times for address and data with respect to $\overline{\text{SRWE}}$ are guaranteed. $\overline{\text{SRWE}}$ has a pulse width of typically 100 ns, minimum 75 ns.

Transmit Operation

The transmit operation and features of the PCnet-ISA controller are controlled by programmable options.

Transmit Function Programming

Automatic transmit features, such as retry on collision, FCS generation/transmission, and pad field insertion, can all be programmed to provide flexibility in the (re-)transmission of messages.

Disable retry on collision (DRTY) is controlled by the DRTY bit of the Mode register (CSR15) in the initialization block.

Automatic pad field insertion is controlled by the APAD_XMT bit in CSR4. If APAD_XMT is set, automatic pad field insertion is enabled, the DXMTFCS feature is over-ridden, and the 4-byte FCS will be added to the transmitted frame unconditionally. If APAD_XMT is cleared, no pad field insertion will take place and runt packet transmission is possible.

The disable FCS generation/transmission feature can be programmed dynamically on a frame by frame basis. See the ADD_FCS description of TMD1.

Transmit FIFO Watermark (XMTFW in CSR80) sets the point at which the BMU (Buffer Management Unit) requests more data from the transmit buffers for the FIFO. This point is based upon how many 16-bit bus transfers (2 bytes) could be performed to the existing empty space in the transmit FIFO.

Transmit Start Point (XMTSP in CSR80) sets the point when the transmitter actually tries to go out on the media. This point is based upon the number of bytes written to the transmit FIFO for the current frame.

When the entire frame is in the FIFO, attempts at transmission of preamble will commence regardless of the value in XMTSP. The default value of XMTSP is 10b, meaning 64 bytes full.

Automatic Pad Generation

Transmit frames can be automatically padded to extend them to 64 data bytes (excluding preamble). This allows the minimum frame size of 64 bytes (512 bits) for 802.3/Ethernet to be guaranteed with no software intervention from the host/controlling process. Setting the APAD_XMT bit in CSR4 enables the automatic padding feature. The pad is placed between the LLC data field and FCS field in the 802.3 frame. FCS is always added if the frame is padded, regardless of the state of DXMTFCS. The transmit frame will be padded by bytes with the value of 00h. The default value of APAD_XMT is 0, and this will disable auto pad generation after RESET.

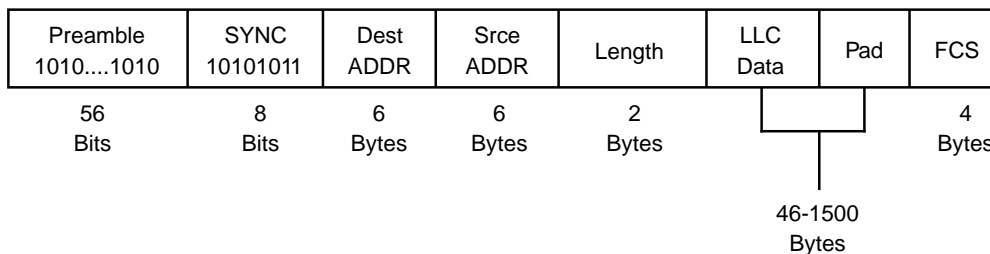

16907B-12

ISO 8802-3 (IEEE/ANSI 802.3) Data Frame

It is the responsibility of upper layer software to correctly define the actual length field contained in the message to correspond to the total number of LLC Data bytes encapsulated in the packet (length field as defined in the IEEE 802.3 standard). The length value contained in the message is not used by the PCnet-ISA controller to compute the actual number of pad bytes to be inserted. The PCnet-ISA controller will append pad bytes dependent on the actual number of bits transmitted onto the network. Once the last data byte of the frame has completed prior to appending the FCS, the PCnet-ISA controller will check to ensure that 544 bits have been transmitted. If not, pad bytes are added to extend the frame size to this value, and the FCS is then added.

The 544 bit count is derived from the following:

Minimum frame size (excluding preamble, including FCS)	64 bytes	512 bits
Preamble/SFD size	8 bytes	64 bits
FCS size	4 bytes	32 bits

To be classed as a minimum-size frame at the receiver, the transmitted frame must contain:

Preamble + (Min Frame Size + FCS) bits

At the point that FCS is to be appended, the transmitted frame should contain:

Preamble + (Min Frame Size - FCS) bits
64 + (512 - 32) bits

A minimum-length transmit frame from the PCnet-ISA controller will, therefore, be 576 bits after the FCS is appended.

Transmit FCS Generation

Automatic generation and transmission of FCS for a transmit frame depends on the value of DXMTFCS bit in CSR15. When DXMTFCS = 0 the transmitter will generate and append the FCS to the transmitted frame. If the automatic padding feature is invoked (APAD_XMT is SET in CSR4), the FCS will be appended by the PCnet-ISA controller regardless of the state of DXMTFCS. Note that the calculated FCS is transmitted most-significant bit first. The default value of DXMTFCS is 0 after RESET.

Transmit Exception Conditions

Exception conditions for frame transmission fall into two distinct categories; those which are the result of normal network operation, and those which occur due to abnormal network and/or host related events.

Normal events which may occur and which are handled autonomously by the PCnet-ISA controller are basically collisions within the slot time with automatic retry. The PCnet-ISA controller will ensure that collisions which occur within 512 bit times from the start of transmission (including preamble) will be automatically retried with no host intervention. The transmit FIFO ensures this by guaranteeing that data contained within the FIFO will not be overwritten until at least 64 bytes (512 bits) of

data have been successfully transmitted onto the network.

If 16 total attempts (initial attempt plus 15 retries) fail, the PCnet-ISA controller sets the RTRY bit in the current transmit TDTE in host memory (TMD2), gives up ownership (sets the OWN bit to zero) for this packet, and processes the next packet in the transmit ring for transmission.

Abnormal network conditions include:

- Loss of carrier
- Late collision
- SQE Test Error (does not apply to 10BASE-T port)

These should not occur on a correctly configured 802.3 network, and will be reported if they do.

When an error occurs in the middle of a multi-buffer frame transmission, the error status will be written in the current descriptor. The OWN bit(s) in the subsequent descriptor(s) will be reset until the STP (the next frame) is found.

Loss of Carrier

A loss of carrier condition will be reported if the PCnet-ISA controller cannot observe receive activity while it is transmitting on the AUI port. After the PCnet-ISA controller initiates a transmission, it will expect to see data "looped back" on the DI± pair. This will internally generate a "carrier sense," indicating that the integrity of the data path to and from the MAU is intact, and that the MAU is operating correctly. This "carrier sense" signal must be asserted before the end of the transmission. If "carrier sense" does not become active in response to the data transmission, or becomes inactive before the end of transmission, the loss of carrier (LCAR) error bit will be set in TMD2 after the frame has been transmitted. The frame will not be re-tried on the basis of an LCAR error. In 10BASE-T mode LCAR will indicate that Jabber or Link Fail state has occurred.

Late Collision

A late collision will be reported if a collision condition occurs after one slot time (512 bit times) after the transmit process was initiated (first bit of preamble commenced). The PCnet-ISA controller will abandon the transmit process for the particular frame, set Late Collision (LCOL) in the associated TMD3, and process the next transmit frame in the ring. Frames experiencing a late collision will not be re-tried. Recovery from this condition must be performed by upper-layer software.

SQE Test Error

During the inter packet gap time following the completion of a transmitted message, the AUI CI± pair is asserted by some transceivers as a self-test. The integral Manchester Encoder/Decoder will expect the SQE Test Message (nominal 10 MHz sequence) to be returned via the CI± pair within a 40 network bit time period after DI± pair goes inactive. If the CI± inputs are not asserted within the 40 network bit time period following

the completion of transmission, then the PCnet-ISA controller will set the CERR bit in CSR0. CERR will be asserted in 10BASE-T mode after transmit if T-MAU is in Link Fail state. CERR will never cause INTR to be activated. It will, however, set the ERR bit in CSR0.

Host related transmit exception conditions include BUFF and UFLO as described in the Transmit Descriptor section.

Receive Operation

The receive operation and features of the PCnet-ISA controller are controlled by programmable options.

Receive Function Programming

Automatic pad field stripping is enabled by setting the ASTRP_RCV bit in CSR4; this can provide flexibility in the reception of messages using the 802.3 frame format.

All receive frames can be accepted by setting the PROM bit in CSR15. When PROM is set, the PCnet-ISA controller will attempt to receive all messages, subject to minimum frame enforcement. Promiscuous mode overrides the effect of the Disable Receive Broadcast bit on receiving broadcast frames.

The point at which the BMU will start to transfer data from the receive FIFO to buffer memory is controlled by the RCVFW bits in CSR80. The default established during reset is 10b, which sets the threshold flag at 64 bytes empty.

Automatic Pad Stripping

During reception of an 802.3 frame the pad field can be stripped automatically. ASTRP_RCV (bit 10 in CSR4) = 1 enables the automatic pad stripping feature. The pad field will be stripped before the frame is passed to the FIFO, thus preserving FIFO space for additional frames. The FCS field will also be stripped, since it is computed at the transmitting station based on the data and pad field characters, and will be invalid for a receive frame that has had the pad characters stripped.

The number of bytes to be stripped is calculated from the embedded length field (as defined in the IEEE 802.3 definition) contained in the frame. The length indicates the actual number of LLC data bytes contained in the message. Any received frame which contains a length field less than 46 bytes will have the pad field stripped (if ASTRP_RCV is set). Receive frames which have a length field of 46 bytes or greater will be passed to the host unmodified.

Since any valid Ethernet Type field value will always be greater than a normal 802.3 Length field (≥ 46), the PCnet-ISA controller will not attempt to strip valid Ethernet frames.

Note that for some network protocols the value passed in the Ethernet Type and/or 802.3 Length field is not compliant with either standard and may cause problems.

The diagram below shows the byte/bit ordering of the received length field for an 802.3 compatible frame format.

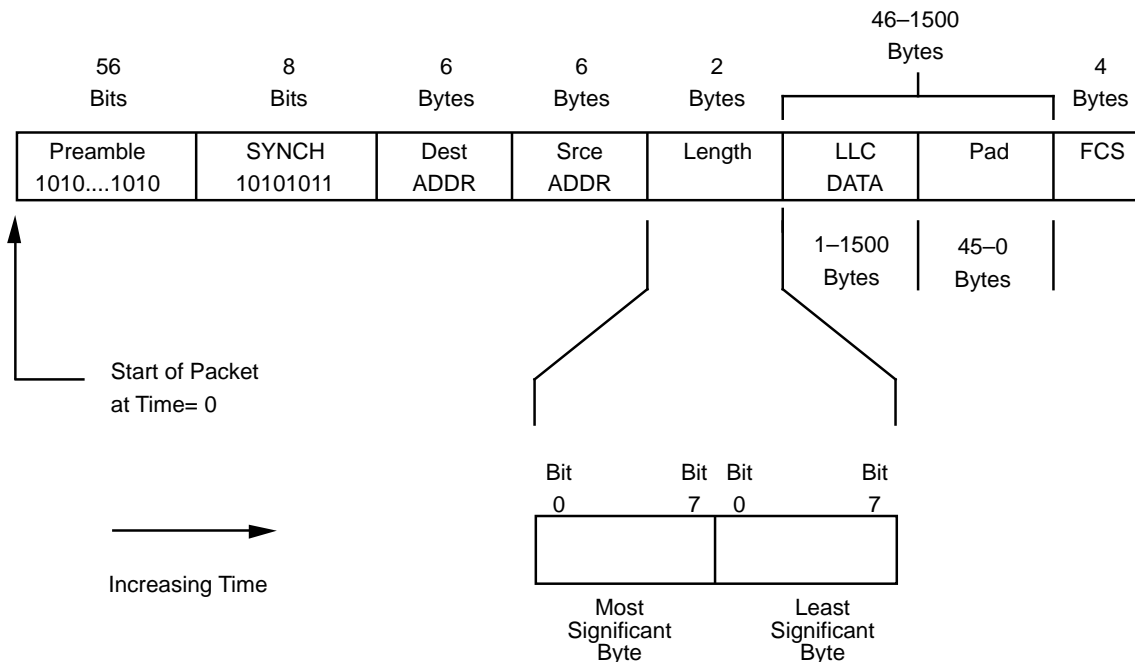

16907B-13

802.3 Frame and Length Field Transmission Order

Receive FCS Checking

Reception and checking of the received FCS is performed automatically by the PCnet-ISA controller. Note that if the Automatic Pad Stripping feature is enabled, the received FCS will be verified against the value computed for the incoming bit stream including pad characters, but it will not be passed to the host. If a FCS error is detected, this will be reported by the CRC bit in RMD1.

Receive Exception Conditions

Exception conditions for frame reception fall into two distinct categories; those which are the result of normal network operation, and those which occur due to abnormal network and/or host related events.

Normal events which may occur and which are handled autonomously by the PCnet-ISA controller are basically collisions within the slot time and automatic runt packet rejection. The PCnet-ISA controller will ensure that collisions which occur within 512 bit times from the start of reception (excluding preamble) will be automatically deleted from the receive FIFO with no host intervention. The receive FIFO will delete any frame which is composed of fewer than 64 bytes provided that the Runt Packet Accept (RPA bit in CSR124) feature has not been enabled. This criteria will be met regardless of whether the receive frame was the first (or only) frame in the FIFO or if the receive frame was queued behind a previously received message.

Abnormal network conditions include:

- FCS errors
- Late collision

These should not occur on a correctly configured 802.3 network and will be reported if they do.

Host related receive exception conditions include MISS, BUFF, and OFLO. These are described in the Receive Descriptor section.

Loopback Operation

During loopback, the FCS logic can be allocated to the receiver by setting the DXMTFCS bit in CSR15.

If DXMTFCS=0, the MAC Engine will calculate and append the FCS to the transmitted message. In this loopback configuration, the receive circuitry cannot detect FCS errors if they occur.

If DXMTFCS=1, the last four bytes of the transmit message must contain the (software generated) FCS computed for the transmit data preceding it. The MAC Engine will transmit the data without addition of an FCS field, and the FCS will be calculated and verified at the receiver.

The loopback facilities of the MAC Engine allow full operation to be verified without disturbance to the network. Loopback operation is also affected by the state of the Loopback Control bits (LOOP, MENDECL, and INTL) in CSR15. This affects whether the internal MENDEC is considered part of the internal or external loopback path.

When in the loopback mode(s), the multicast address detection feature of the MAC Engine, programmed by the contents of the Logical Address Filter (LADRF [63:0] in CSR 8-11) can only be tested when DXMTFCS= 1, allocating the FCS generator to the receiver. All other features operate identically in loopback as in normal operation, such as automatic transmit padding and receive pad stripping.

When performing an internal loopback, no frame will be transmitted to the network. However, when the PCnet-ISA controller is configured for internal loopback the receiver will not be able to detect network traffic. AUI external loopback tests will transmit frames onto the network, and the PCnet-ISA controller will receive network traffic while configured for external loopback. 10BASE-T external loopback should never be used in a live network. 10BASE-T external loopback provides a means of looping Transmit data to the receive input without asserting a collision. This mode allows a board test to verify both the transmit and receive paths to the 10BASE-T connector. Unless the Runt Packet Accept feature is enabled, all loopback frames must contain at least 64 bytes of data.

LEDs

The PCnet-ISA controller's LED control logic allows programming of the status signals, which are displayed on 3 LED outputs. One LED (LED0) is dedicated to displaying 10BASE-T Link Status. The status signals available are Collision, Jabber, Receive, Receive Polarity (active when receive polarity is okay), and Transmit. If more than one status signal is enabled, they are ORed together. An optional pulse stretcher is available for each programmable output. This allows emulation of the TPEX (Am79C98) and TPEX+ (Am79C100) LED outputs.

Signal	Behavior
LNKST	Active during Link OK Not active during Link Down
RCV	Active while receiving data
RVPOL	Active during receive polarity is OK Not active during reverse receive polarity
XMT	Active while transmitting data

Each status signal is ANDed with its corresponding enable signal. The enabled status signals run to a common OR gate:

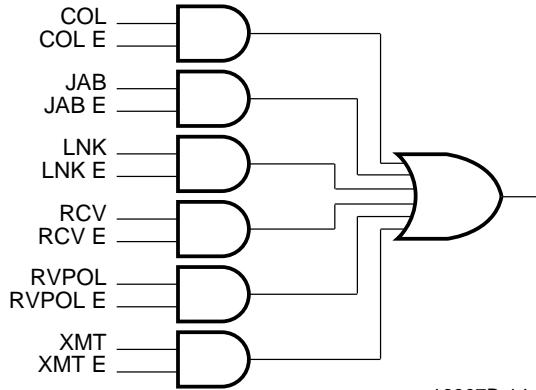

16907B-14

LED Control Logic

The output from the OR gate is run through a pulse stretcher, which consists of a 3-bit shift register clocked at 38 Hz. The data input of the shift register is at logic 0. The OR gate output asynchronously sets all three bits of the shift register when its output goes active. The output of the shift register controls the associated LEDx pin. Thus, the pulse stretcher provides an LED output of 52 ms to 78 ms.

PCnet-ISA CONTROLLER REGISTERS

The PCnet-ISA controller implements all LANCE (Am7990) registers, plus a number of additional registers. The PCnet-ISA controller registers are compatible with the original LANCE, but there are some places where previously reserved LANCE bits are now used by the PCnet-ISA controller. If the reserved LANCE bits were used as recommended, there should be no compatibility problems.

Register Access

Internal registers are accessed in a two-step operation. First, the address of the register to be accessed is written into the register address port (RAP). Subsequent read or write operations will access the register pointed to by the contents of the RAP. The data will be read from (or written to) the selected register through the data port, either the register data port (RDP) for control and status registers (CSR) or the ISACSR register data port (IDP) for ISA control and status registers (ISACSR).

RAP: Register Address Port

Bit	Name	Description
15-7	RES	Reserved locations. Read and written as zeroes.
6-0	RAP	Register Address Port select. Selects the CSR or ISACSR location to be accessed. RAP is cleared by <u>RESET</u> .

Control and Status Registers

CSR0: PCnet-ISA Controller Status

Bit	Name	Description
15	ERR	Error is set by the ORing of BABL, CERR, MISS, and MERR. ERR remains set as long as any of the error flags are true. ERR is read only; write operations are ignored.
14	BABL	Babble is a transmitter time-out error. It indicates that the transmitter has been on the channel longer than the time required to send the maximum length frame. BABL will be set if 1519 bytes or greater are transmitted. When BABL is set, IRQ is asserted if IENA = 1 and the mask bit BABLM (CSR3.14) is clear. BABL assertion will set the ERR bit. BABL is set by the MAC layer and cleared by writing a "1". Writing a "0" has no effect. BABL is cleared

13 CERR

by RESET or by setting the STOP bit.

Collision Error indicates that the collision inputs to the AUI port failed to activate within 20 network bit times after chip terminated transmission (SQE Test). This feature is a transceiver test feature. CERR will be set in 10BASE-T mode during transmit if in Link Fail state.

CERR assertion will not result in an interrupt being generated. CERR assertion will set the ERR bit.

CERR is set by the MAC layer and cleared by writing a "1". Writing a "0" has no effect. CERR is cleared by RESET or by setting the STOP bit.

12 MISS

Missed Frame is set when PCnet-ISA controller has lost an incoming receive frame because a Receive Descriptor was not available. This bit is the only indication that receive data has been lost since there is no receive descriptor available for status information.

When MISS is set, IRQ is asserted if IENA = 1 and the mask bit MISSM (CSR3.12) is clear. MISS assertion will set the ERR bit.

MISS is set by the Buffer Management Unit and cleared by writing a "1". Writing a "0" has no effect. MISS is cleared by RESET or by setting the STOP bit.

11 MERR

Memory Error is set when PCnet-ISA controller is a bus master and has not received \overline{DACK} assertion after 50 μ s after DRQ assertion. Memory Error indicates that PCnet-ISA controller is not receiving bus mastership in time to prevent overflow/underflow conditions in the receive and transmit FIFOs.

(MERR indicates a slightly different condition for the LANCE; for the LANCE MERR occurs when \overline{READY} has not been asserted 25.6 μ s after the address has been asserted.)

When MERR is set, IRQ is asserted if IENA = 1 and the mask bit MERRM (CSR3.11) is clear.

		MERR assertion will set the ERR bit.			and INTR is set, IRQ will be active.
		MERR is set by the Bus Interface Unit and cleared by writing a "1". Writing a "0" has no effect. MERR is cleared by RESET or by setting the STOP bit.			INTR is cleared automatically when the condition that caused interrupt is cleared.
10	RINT	Receive Interrupt is set after reception of a receive frame and toggling of the OWN bit in the last buffer in the Receive Descriptor Ring.	6	IENA	INTR is read only. INTR is cleared by RESET or by setting the STOP bit.
		When RINT is set, IRQ is asserted if IENA = 1 and the mask bit RINTM (CSR3.10) is clear.			Interrupt Enable allows IRQ to be active if the Interrupt Flag is set. If IENA = "0" then IRQ will be disabled regardless of the state of INTR.
		RINT is set by the Buffer Management Unit after the last receive buffer has been updated and cleared by writing a "1". Writing a "0" has no effect. RINT is cleared by RESET or by setting the STOP bit.	5	RXON	IENA is set by writing a "1" and cleared by writing a "0". IENA is cleared by RESET or by setting the STOP bit.
9	TINT	Transmit Interrupt is set after transmission of a transmit frame and toggling of the OWN bit in the last buffer in the Transmit Descriptor Ring.			Receive On indicates that the Receive function is enabled. RXON is set if DRX (CSR15.0) = "0" after the START bit is set. If INIT and START are set together, RXON will not be set until after the initialization block has been read in.
		When TINT is set, IRQ is asserted if IENA = 1 and the mask bit TINTM (CSR3.9) is clear.			RXON is read only. RXON is cleared by RESET or by setting the STOP bit.
		TINT is set by the Buffer Management Unit after the last transmit buffer has been updated and cleared by writing a "1". Writing a "0" has no effect. TINT is cleared by RESET or by setting the STOP bit.	4	TXON	Transmit On indicates that the Transmit function is enabled. TXON is set if DTX (CSR15.1) = "0" after the START bit is set. If INIT and START are set together, TXON will not be set until after the initialization block has been read in.
8	IDON	Initialization Done indicates that the initialization sequence has completed. When IDON is set, PCnet-ISA controller has read the Initialization block from memory.			TXON is read only. TXON is cleared by RESET or by setting the STOP bit.
		When IDON is set, IRQ is asserted if IENA = 1 and the mask bit IDONM (CSR3.8) is clear.	3	TDMD	Transmit Demand, when set, causes the Buffer Management Unit to access the Transmit Descriptor Ring without waiting for the poll-time counter to elapse. If TXON is not enabled, TDMD bit will be reset and no Transmit Descriptor Ring access will occur. TDMD is required to be set if the DPOLL bit in CSR4 is set; setting TDMD while DPOLL = 0 merely hastens the PCnet-ISA controller's response to a Transmit Descriptor Ring Entry.
		IDON is set by the Buffer Management Unit after the initialization block has been read from memory and cleared by writing a "1". Writing a "0" has no effect. IDON is cleared by RESET or by setting the STOP bit.			TDMD is set by writing a "1". Writing a "0" has no effect. TDMD will be cleared by the Buffer Management Unit when it fetches a Transmit Descriptor. TDMD is cleared by RESET or by setting the STOP bit.
7	INTR	Interrupt Flag indicates that one or more of the following interrupt causing conditions has occurred: BABL, MISS, MERR, MPCO, RCVCCO, RINT, TINT, IDON, JAB or TXSTRT; and its associated mask bit is clear. If IENA = 1			

2	STOP	<p>STOP assertion disables the chip from all external activity. The chip remains inactive until either STRT or INIT are set. If STOP, STRT and INIT are all set together, STOP will override STRT and INIT.</p> <p>STOP is set by writing a “1” or by RESET. Writing a “0” has no effect. STOP is cleared by setting either STRT or INIT.</p>	7-0	IADR [23:16]	<p>Upper 8 bits of the address of the Initialization Block. Bit locations 15-8 must be written with zeros. Whenever this register is written, CSR17 is updated with CSR2’s contents.</p> <p>Read/Write accessible only when the STOP bit in CSR0 is set. Unaffected by RESET.</p>
1	STRT	<p>STRT assertion enables PCnet-ISA controller to send and receive frames, and perform buffer management operations. Setting STRT clears the STOP bit. If STRT and INIT are set together, PCnet-ISA controller initialization will be performed first.</p> <p>STRT is set by writing a “1”. Writing a “0” has no effect. STRT is cleared by RESET or by setting the STOP bit.</p>			
0	INIT	<p>INIT assertion enables PCnet-ISA controller to begin the initialization procedure which reads in the initialization block from memory. Setting INIT clears the STOP bit. If STRT and INIT are set together, PCnet-ISA controller initialization will be performed first. INIT is not cleared when the initialization sequence has completed.</p> <p>INIT is set by writing a “1”. Writing a “0” has no effect. INIT is cleared by RESET or by setting the STOP bit.</p>			

CSR3: Interrupt Masks and Deferral Control

Bit	Name	Description
15	RES	Reserved location. Written as zero and read as undefined.
14	BABLM	<p>Babble Mask. If BABLM is set, the BABL bit in CSR0 will be masked and will not set INTR flag in CSR0.</p> <p>BABLM is cleared by RESET and is not affected by STOP.</p>
13	RES	Reserved location. Written as zero and read as undefined.
12	MISSM	<p>Missed Frame Mask. If MISSM is set, the MISS bit in CSR0 will be masked and will not set INTR flag in CSR0.</p> <p>MISSM is cleared by RESET and is not affected by STOP.</p>
11	MERRM	<p>Memory Error Mask. If MERRM is set, the MERR bit in CSR0 will be masked and will not set INTR flag in CSR0.</p> <p>MERRM is cleared by RESET and is not affected by STOP.</p>
10	RINTM	<p>Receive Interrupt Mask. If RINTM is set, the RINT bit in CSR0 will be masked and will not set INTR flag in CSR0.</p> <p>RINTM is cleared by RESET and is not affected by STOP.</p>
9	TINTM	<p>Transmit Interrupt Mask. If TINTM is set, the TINT bit in CSR0 will be masked and will not set INTR flag in CSR0.</p> <p>TINTM is cleared by RESET and is not affected by STOP.</p>
8	IDONM	<p>Initialization Done Mask. If IDONM is set, the IDON bit in CSR0 will be masked and will not set INTR flag in CSR0.</p> <p>IDONM is cleared by RESET and is not affected by STOP.</p>
7-5	RES	Reserved locations. Written as zero and read as undefined.

CSR1: IADR[15:0]

Bit	Name	Description
15-0	IADR [15:0]	<p>Lower address of the Initialization address register. Bit location 0 must be zero. Whenever this register is written, CSR16 is updated with CSR1’s contents.</p> <p>Read/Write accessible only when the STOP bit in CSR0 is set. Unaffected by RESET.</p>

CSR2: IADR[23:16]

Bit	Name	Description
15-8	RES	Reserved locations. Read and written as zero.

4	DXMT2PD	<p>Disable Transmit Two Part Deferral. If DXMT2PD is set, Transmit Two Part Deferral will be disabled.</p> <p>DXMT2PD is cleared by RESET and is not affected by STOP.</p>	11	APAD_XMT	<p>D POLL is cleared by RESET.</p> <p>Auto Pad Transmit. When set, APAD_XMT enables the automatic padding feature. Transmit frames will be padded to extend them to 64 bytes, including FCS. The FCS is calculated for the entire frame (including pad) and appended after the pad field. APAD_XMT will override the programming of the DXMTFCS bit (CSR15.3).</p> <p>APAD_XMT is reset by activation of the RESET pin.</p>
3	EMBA	<p>Enable Modified Back-off Algorithm. If EMBA is set, a modified back-off algorithm is implemented.</p> <p>Read/Write accessible. EMBA is cleared by RESET and is not affected by STOP.</p>			
2-0	RES	Reserved locations. Written as zero and read as undefined.	10	ASTRP_RCV	<p>ASTRP_RCV enables the automatic pad stripping feature. The pad and FCS fields will be stripped from receive frames and not placed in the FIFO.</p> <p>ASTRP_RCV is reset by activation of the RESET pin.</p>
CSR4: Test and Features Control					
Bit	Name	Description			
15	ENTST	<p>Enable Test Mode operation. When ENTST is set, writing to test mode registers CSR124 and CSR126 is allowed, and other register test functions are enabled. In order to set ENTST, it must be written with a "1" during the first write access to CSR4 after RESET. Once a "0" is written to this bit location, ENTST cannot be set until after the PCnet-ISA controller is reset.</p> <p>ENTST is cleared by RESET.</p>	9	MFCO	<p>Missed Frame Counter Overflow Interrupt.</p> <p>This bit indicates the MFC (CSR112) has overflowed. Can be cleared by writing a "1" to this bit. Also cleared by RESET or setting the STOP bit. Writing a "0" has no effect.</p>
14	DMAPLUS	<p>When DMAPLUS = "1", the burst transaction counter in CSR80 is disabled. If DMAPLUS = "0", the burst transaction counter is enabled.</p> <p>DMA-PLUS is cleared by RESET.</p>	8	MFCOM	<p>Missed Frame Counter Overflow Mask.</p> <p>If MFCOM is set, MFCO will not set INTR in CSR0.</p> <p>MFCOM is set by Reset and is not affected by STOP.</p>
			7-6	RES	Reserved locations. Read and written as zero.
			5	RCVCCO	<p>Receive Collision Counter Overflow.</p> <p>This bit indicates the Receive Collision Counter (CSR114) has overflowed. It can be cleared by writing a 1 to this bit. Also cleared by RESET or setting the STOP bit. Writing a 0 has no effect.</p>
13	TIMER	<p>Timer Enable Register. If TIMER is set, the Bus Timer Register, CSR82, is enabled. If TIMER is set, CSR82 must be written with a value. If TIMER is cleared, the Bus Timer Register is disabled.</p> <p>TIMER is cleared by RESET.</p>	4	RCVCCOM	<p>Receive Collision Counter Overflow Mask.</p> <p>If RCVCCOM is set, RCVCCO will not set INTR in CSR0.</p> <p>RCVCCOM is set by RESET and is not affected by STOP.</p>
12	DPOLL	<p>Disable Transmit Polling. If DPOLL is set, the Buffer Management Unit will disable transmit polling. Likewise, if DPOLL is cleared, automatic transmit polling is enabled. If DPOLL is set, TDMD bit in CSR0 must be periodically set in order to initiate a manual poll of a transmit descriptor. Transmit descriptor polling will not take place if TXON is reset.</p>	3	TXSTRT	<p>Transmit Start status is set whenever PCnet-ISA controller begins transmission of a frame.</p> <p>When TXSTRT is set, IRQ is asserted if IENA = 1 and the mask bit TXSTRTM (CSR4.2) is clear.</p>

2	TXSTRM	<p>TXSTRM is set by the MAC Unit and cleared by writing a "1", setting RESET or setting the STOP bit. Writing a "0" has no effect.</p> <p>Transmit Start Mask. If TXSTRM is set, the TXSTRM bit in CSR4 will be masked and will not set INTR flag in CSR0.</p> <p>TXS-TRTM is set by RESET and is not affected by STOP.</p>
1	JAB	<p>Jabber Error is set when the PCnet-ISA controller Twisted-pair MAU function exceeds an allowed transmission limit. Jabber is set by the TMAU cell and can only be asserted in 10BASE-T mode.</p> <p>When JAB is set, IRQ is asserted if IENA = 1 and the mask bit JABM (CSR4.0) is clear.</p> <p>The JAB bit can be reset even if the jabber condition is still present.</p> <p>JAB is set by the TMAU circuit and cleared by writing a "1". Writing a "0" has no effect. JAB is also cleared by RESET or setting the STOP bit.</p>
0	JABM	<p>Jabber Error Mask. If JABM is set, the JAB bit in CSR4 will be masked and will not set INTR flag in CSR0.</p> <p>JABM is set by RESET and is not affected by STOP.</p>

CSR6: RCV/XMT Descriptor Table Length

Bit	Name	Description
15-12	TLEN	<p>Contains a copy of the transmit encoded ring length (TLEN) field read from the initialization block during PCnet-ISA controller initialization. This field is written during the PCnet-ISA controller initialization routine.</p> <p>Read accessible only when STOP bit is set. Write operations have no effect and should not be performed. TLEN is only defined after initialization.</p>
11-8	RLEN	<p>Contains a copy of the receive encoded ring length (RLEN) read from the initialization block during PCnet-ISA controller initialization. This field is written during the PCnet-ISA controller initialization routine.</p>

7-0	RES	<p>Read accessible only when STOP bit is set. Write operations have no effect and should not be performed. RLEN is only defined after initialization.</p> <p>Reserved locations. Read as zero. Write operations should not be performed.</p>
-----	-----	--

CSR8: Logical Address Filter, LADRF[15:0]

Bit	Name	Description
15-0	LADRF[15:0]	<p>Logical Address Filter, LADRF [15:0]. Undefined until initialized either automatically by loading the initialization block or directly by an I/O write to this register.</p> <p>Read/write accessible only when STOP bit is set.</p>

CSR9: Logical Address Filter, LADRF[31:16]

Bit	Name	Description
15-0	LADRF[31:16]	<p>Logical Address Filter, LADRF[31:16]. Undefined until initialized either automatically by loading the initialization block or directly by an I/O write to this register.</p> <p>Read/write accessible only when STOP bit is set.</p>

CSR10: Logical Address Filter, LADRF[47:32]

Bit	Name	Description
15-0	LADRF[47:32]	<p>Logical Address Filter, LADRF[47:32]. Undefined until initialized either automatically by loading the initialization block or directly by an I/O write to this register.</p> <p>Read/write accessible only when STOP bit is set.</p>

CSR11: Logical Address Filter, LADRF[63:48]

Bit	Name	Description
15-0	LADRF[63:48]	<p>Logical Address Filter, LADRF[63:48]. Undefined until initialized either automatically by loading the initialization block or directly by an I/O write to this register.</p>

Read/write accessible only when STOP bit is set. 15 PROM Promiscuous Mode. When PROM = "1", all incoming receive frames are accepted.

CSR12: Physical Address Register, PADR[15:0]

Bit	Name	Description			
15-0	PADR[15:0]	Physical Address Register, PADR[15:0]. Undefined until initialized either automatically by loading the initialization block or directly by an I/O write to this register. The PADR bits are transmitted PADR[0] first and PADR[47] last. Read/write accessible only when STOP bit is set.	14	DRCVBC	Disable Receive Broadcast. When set, disables the PCnet-ISA controller from responding to broadcast messages. Used for protocols that do not support broadcast addressing, except as a function of multicast. DRCVBC is cleared by activation of the RESET pin (broadcast messages will be received). Read/write accessible only when STOP bit is set.

CSR13: Physical Address Register, PADR[31:16]

Bit	Name	Description			
15-0	PADR[31:16]	Physical Address Register, PADR[31:16]. Undefined until initialized either automatically by loading the initialization block or directly by an I/O write to this register. The PADR bits are transmitted PADR[0] first and PADR[47] last. Read/write accessible only when STOP bit is set.	13	DRCVPA	Disable Receive Physical Address. When set, the physical address detection (Station or node ID) of the PCnet-ISA controller will be disabled. Frames addressed to the nodes individual physical address will not be recognized (although the frame may be accepted by the EADI mechanism). Read/write accessible only when STOP bit is set.
			12	DLNKTST	Disable Link Status. When DLNKTST = "1", monitoring of Link Pulses is disabled. When DLNKTST = "0", monitoring of Link Pulses is enabled. This bit only has meaning when the 10BASE-T network interface is selected. Read/write accessible only when STOP bit is set.

CSR14: Physical Address Register, PADR[47:32]

Bit	Name	Description			
15-0	PADR[47:32]	Physical Address Register, PADR[47:32]. Undefined until initialized either automatically by loading the initialization block or directly by an I/O write to this register. The PADR bits are transmitted PADR[0] first and PADR[47] last. Read/write accessible only when STOP bit is set.	11	DAPC	Disable Automatic Polarity Correction. When DAPC = "1", the 10BASE-T receive polarity reversal algorithm is disabled. Likewise, when DAPC = "0", the polarity reversal algorithm is enabled. This bit only has meaning when the 10BASE-T network interface is selected. Read/write accessible only when STOP bit is set.

CSR15: Mode Register

Bit	Name	Description			
		This register's fields are loaded during the PCnet-ISA controller initialization routine with the corresponding Initialization Block values. The register can also be loaded directly by an I/O write. Activating the RESET pin clears all bits of CSR15 to zero.	10	MENDECL	MENDEC Loopback Mode. See the description of the LOOP bit in CSR15. Read/write accessible only when STOP bit is set.
			9	LRT/TSEL	Low Receive Threshold (T-MAU Mode only)

		PORTSEL[1:0]	Network Port
		0 0	AUI
		0 1	10BASE-T
		1 0	GPSI*
		1 1	Reserved

**Refer to the section on General Purpose Serial Interface for detailed information on accessing GPSI.*

LRT	Transmit Mode Select (AUI Mode only)	6	INTL	Internal Loopback. See the description of LOOP, CSR15.2. Read/write accessible only when STOP bit is set.
	Low Receive Threshold. When LRT = "1", the internal twisted pair receive thresholds are reduced by 4.5 dB below the standard 10BASE-T value (approximately 3/5) and the unsquelch threshold for the RXD circuit will be 180–312 mV peak. When LRT = "0", the unsquelch threshold for the RXD circuit will be the standard 10BASE-T value, 300–520 mV peak. In either case, the RXD circuit post squelch threshold will be one half of the unsquelch threshold. This bit only has meaning when the 10BASE-T network interface is selected. Read/write accessible only when STOP bit is set. Cleared by RESET.	5	DRTY	Disable Retry. When DRTY = "1", PCnet-ISA controller will attempt only one transmission. If DRTY = "0", PCnet-ISA controller will attempt 16 retry attempts before signaling a retry error. Read/write accessible only when STOP bit is set.
TSEL	Transmit Mode Select. TSEL controls the levels at which the AUI drivers rest when the AUI transmit port is idle. When TSEL = 0, DO+ and DO- yield "zero" differential to operate transformer coupled loads (Ethernet 2 and 802.3). When TSEL = 1, the DO+ idles at a higher value with respect to DO-, yielding a logical HIGH state (Ethernet 1). This bit only has meaning when the AUI network interface is selected. Read/write accessible only when STOP bit is set. Cleared by RESET.	4	FCOLL	Force Collision. This bit allows the collision logic to be tested. PCnet-ISA controller must be in internal loopback for FCOLL to be valid. If FCOLL = "1", a collision will be forced during loopback transmission attempts; a Retry Error will ultimately result. If FCOLL = "0", the Force Collision logic will be disabled. Read/write accessible only when STOP bit is set.
		3	DXMTFCS	Disable Transmit CRC (FCS). When DXMTFCS = 0, the transmitter will generate and append a FCS to the transmitted frame. When DXMTFCS = 1, the FCS logic is allocated to the receiver and no FCS is generated or sent with the transmitted frame.
8-7	PORTSEL [1:0]			See also the ADD_FCS bit in TMD1. If DXMTFCS is set, no FCS will be generated. If both DXMTFCS is set and ADD_FCS is clear for a particular frame, no FCS will be generated. If ADD_FCS is set for a particular frame, the state of DXMTFCS is ignored and a FCS will be appended on that frame by the transmit circuitry.

Port Select bits allow for software controlled selection of the network medium. Medium selection can be overridden by the MAUSEL pin if the XMAUSEL bit in the ISA Configuration Register is set. Read/write accessible only when STOP bit is set. Cleared by RESET. The network port configuration are as follows:

In loopback mode, this bit determines if the transmitter appends FCS or if the receiver checks the FCS.

This bit was called DTCR in the LANCE (Am7990).

Read/write accessible only when STOP bit is set.

2 LOOP Loopback Enable allows PCnet-ISA controller to operate in full duplex mode for test purposes. When LOOP = "1", loopback is enabled. In combination with INTL and MENDECL, various loopback modes are defined as follows:

LOOP	INTL	MENDECL	Loopback Mode
0	X	X	Non-loopback
1	0	X	External Loopback
1	1	0	Internal Loopback Include MENDEC
1	1	1	Internal Loopback Exclude MENDEC

Read/write accessible only when STOP bit is set. LOOP is cleared by RESET.

1 DTX Disable Transmit. If this bit is set, the PCnet-ISA controller will not access the Transmit Descriptor Ring and, therefore, no transmissions will occur. DTX = "0" will set TXON bit (CSR0.4) after STRT (CSR0.1) is asserted. DTX is defined after the initialization block is read.

Read/write accessible only when STOP bit is set.

0 DRX Disable Receiver. If this bit is set, the PCnet-ISA controller will not access the Receive Descriptor Ring and, therefore, all receive frame data are ignored. DRX = "0" will set RXON bit (CSR0.5) after STRT (CSR0.1) is asserted. DRX is defined after the initialization block is read.

Read/write accessible only when STOP bit is set.

CSR16: Initialization Block Address Lower

Bit	Name	Description
15-0	IADR	Lower 16 bits of the address of the Initialization Block. Bit location 0 must be zero. This register

is an alias of CSR1. Whenever this register is written, CSR1 is updated with CSR16's contents.

Read/Write accessible only when the STOP bit in CSR0 is set. Unaffected by RESET.

CSR17: Initialization Block Address Upper

Bit	Name	Description
15-8	RES	Reserved locations. Written as zero and read as undefined.
7-0	IADR	Upper 8 bits of the address of the Initialization Block. Bit locations 15-8 must be written with zeros. This register is an alias of CSR2. Whenever this register is written, CSR2 is updated with CSR17's contents.

Read/Write accessible only when the STOP bit in CSR0 is set. Unaffected by RESET.

CSR18-19: Current Receive Buffer Address

Bit	Name	Description
31-24	RES	Reserved locations. Written as zero and read as undefined.
23-0	CRBA	Contains the current receive buffer address to which the PCnet-ISA controller will store incoming frame data.

Read/write accessible only when STOP bit is set.

CSR20-21: Current Transmit Buffer Address

Bit	Name	Description
31-24	RES	Reserved locations. Written as zero and read as undefined.
23-0	CXBA	Contains the current transmit buffer address from which the PCnet-ISA controller is transmitting.

Read/write accessible only when STOP bit is set.

CSR22-23: Next Receive Buffer Address

Bit	Name	Description
31-24	RES	Reserved locations. Written as zero and read as undefined.
23-0	NRBA	Contains the next receive buffer address to which the PCnet-ISA

controller will store incoming frame data.
Read/write accessible only when STOP bit is set.

CSR24-25: Base Address of Receive Ring

Bit	Name	Description
31-24	RES	Reserved locations. Written as zero and read as undefined.
23-0	BADR	Contains the base address of the Receive Ring. Read/write accessible only when STOP bit is set.

CSR26-27: Next Receive Descriptor Address

Bit	Name	Description
31-24	RES	Reserved locations. Written as zero and read as undefined.
23-0	NRDA	Contains the next RDRE address pointer. Read/write accessible only when STOP bit is set.

CSR28-29: Current Receive Descriptor Address

Bit	Name	Description
31-24	RES	Reserved locations. Written as zero and read as undefined.
23-0	CRDA	Contains the current RDRE address pointer. Read/write accessible only when STOP bit is set.

CSR30-31: Base Address of Transmit Ring

Bit	Name	Description
31-24	RES	Reserved locations. Written as zero and read as undefined.
23-0	BADX	Contains the base address of the Transmit Ring. Read/write accessible only when STOP bit is set.

CSR32-33: Next Transmit Descriptor Address

Bit	Name	Description
31-24	RES	Reserved locations. Written as zero and read as undefined.
23-0	NXDA	Contains the next TDRE address pointer. Read/write accessible only when STOP bit is set.

CSR34-35: Current Transmit Descriptor Address

Bit	Name	Description
31-24	RES	Reserved locations. Written as zero and read as undefined.
23-0	CXDA	Contains the current TDRE address pointer. Read/write accessible only when STOP bit is set.

CSR36-37: Next Next Receive Descriptor Address

Bit	Name	Description
31-0	NNRDA	Contains the next next RDRE address pointer. Read/write accessible only when STOP bit is set.

CSR38-39: Next Next Transmit Descriptor Address

Bit	Name	Description
31-0	NNXDA	Contains the next next TDRE address pointer. Read/write accessible only when STOP bit is set.

CSR40-41: Current Receive Status and Byte Count

Bit	Name	Description
31-24	CRST	Current Receive Status. This field is a copy of bits 15:8 of RMD1 of the current receive descriptor.

		Read/write accessible only when STOP bit is set.
23-12	RES	Reserved locations. Written as zero and read as undefined.
11-0	CRBC	Current Receive Byte Count. This field is a copy of the BCNT field of RMD2 of the current receive descriptor. Read/write accessible only when STOP bit is set.

to trigger the descriptor ring polling operation of the PCnet-ISA controller.

Read/write accessible only when STOP bit is set.

CSR42-43: Current Transmit Status and Byte Count

Bit	Name	Description
31-24	CXST	Current Transmit Status. This field is a copy of bits 15:8 of TMD1 of the current transmit descriptor. Read/write accessible only when STOP bit is set.
23-12	RES	Reserved locations. Written as zero and read as undefined.
11-0	CXBC	Current Transmit Byte Count. This field is a copy of the BCNT field of TMD2 of the current transmit descriptor. Read/write accessible only when STOP bit is set.

CSR44-45: Next Receive Status and Byte Count

Bit	Name	Description
31-24	NRST	Next Receive Status. This field is a copy of bits 15:8 of RMD1 of the next receive descriptor. Read/write accessible only when STOP bit is set.
23-12	RES	Reserved locations. Written as zero and read as undefined.
11-0	NRBC	Next Receive Byte Count. This field is a copy of the BCNT field of RMD2 of the next receive descriptor. Read/write accessible only when STOP bit is set.

CSR46: Poll Time Counter

Bit	Name	Description
15-0	POLL	Poll Time Counter. This counter is incremented by the PCnet-ISA controller microcode and is used

CSR47: Polling Interval

Bit	Name	Description
31-16	RES	Reserved locations. Written as zero and read as undefined.
15-0	POLLINT	<p>Polling Interval. This register contains the time that the PCnet-ISA controller will wait between successive polling operations. The POLLINT value is expressed as the two's complement of the desired interval, where each bit of POLLINT represents one-half of an XTAL1 period of time. POLLINT[3:0] are ignored. (POLLINT[16] is implied to be a one, so POLLINT[15] is significant, and does not represent the sign of the two's complement POLLINT value.)</p> <p>The default value of this register is 0000. This corresponds to a polling interval of 32,768 XTAL1 periods. The POLLINT value of 0000 is created during the microcode initialization routine, and therefore might not be seen when reading CSR47 after RESET.</p>

If the user desires to program a value for POLLINT other than the default, then the correct procedure is to first set INIT only in CSR0. Then, when the initialization sequence is complete, the user must set STOP in CSR0. Then the user may write to CSR47 and then set STRT in CSR0. In this way, the default value of 0000 in CSR47 will be overwritten with the desired user value.

Read/write accessible only when STOP bit is set.

CSR48-49: Temporary Storage

Bit	Name	Description
31-0	TMP0	Temporary Storage location. Read/write accessible only when STOP bit is set.

CSR50-51: Temporary Storage

Bit	Name	Description
31-0	TMP1	Temporary Storage location. Read/write accessible only when STOP bit is set.

CSR52-53: Temporary Storage

Bit	Name	Description
31-0	TMP2	Temporary Storage location. Read/write accessible only when STOP bit is set.

CSR54-55: Temporary Storage

Bit	Name	Description
31-0	TMP3	Temporary Storage location. Read/write accessible only when STOP bit is set.

CSR56-57: Temporary Storage

Bit	Name	Description
31-0	TMP4	Temporary Storage location. Read/write accessible only when STOP bit is set.

CSR58-59: Temporary Storage

Bit	Name	Description
31-0	TMP5	Temporary Storage location. Read/write accessible only when STOP bit is set.

CSR60-61: Previous Transmit Descriptor Address

Bit	Name	Description
31-24	RES	Reserved locations. Written as zero and read as undefined.
23-0	PXDA	Contains the previous TDRE address pointer. The PCnet-ISA controller has the capability to stack multiple transmit frames. Read/write accessible only when STOP bit is set.

CSR62-63: Previous Transmit Status and Byte Count

Bit	Name	Description
31-24	PXST	Previous Transmit Status. This field is a copy of bits 15:8 of TMD1 of the previous transmit descriptor. Read/write accessible only when STOP bit is set.
23-12	RES	Reserved locations. Written as zero and read as undefined. Accessible only when STOP bit is set.
11-0	PXBC	Previous Transmit Byte Count. This field is a copy of the BCNT field of TMD2 of the previous transmit descriptor. Read/write accessible only when STOP bit is set.

CSR64-65: Next Transmit Buffer Address

Bit	Name	Description
31-24	RES	Reserved locations. Written as zero and read as undefined.
23-0	NXBA	Contains the next transmit buffer address from which the PCnet-ISA controller will transmit an outgoing frame. Read/write accessible only when STOP bit is set.

CSR66-67: Next Transmit Status and Byte Count

Bit	Name	Description
31-24	NXST	Next Transmit Status. This field is a copy of bits 15:8 of TMD1 of the next transmit descriptor. Read/write accessible only when STOP bit is set.
23-12	RES	Reserved locations. Written as zero and read as undefined. Accessible only when STOP bit is set.
11-0	NXBC	Next Transmit Byte Count. This field is a copy of the BCNT field of TMD2 of the next transmit descriptor. Read/write accessible only when STOP bit is set.

CSR68-69: Transmit Status Temporary Storage

Bit	Name	Description
31-0	XSTMP	Transmit Status Temporary Storage location. Read/write accessible only when STOP bit is set.

value in the RLEN field of the initialization block. This register can be manually altered; the actual receive ring length is defined by the current value in this register.

Read/write accessible only when STOP bit is set.

CSR70-71: Temporary Storage

Bit	Name	Description
31-0	TMP8	Temporary Storage location. Read/write accessible only when STOP bit is set.

CSR78: Transmit Ring Length

Bit	Name	Description
15-0	XMTRL	Transmit Ring Length. Contains the two's complement of the transmit descriptor ring length. This register is initialized during the PCnet-ISA controller initialization routine based on the value in the TLEN field of the initialization block. This register can be manually altered; the actual transmit ring length is defined by the current value in this register. Read/write accessible only when STOP bit is set.

CSR72: Receive Ring Counter

Bit	Name	Description
15-0	RCVRC	Receive Ring Counter location. Contains a Two's complement binary number used to number the current receive descriptor. This counter interprets the value in CSR76 as pointing to the first descriptor; a two's complement value of -1 (FFFFh) corresponds to the last descriptor in the ring. Read/write accessible only when STOP bit is set.

CSR80: Burst and FIFO Threshold Control

Bit	Name	Description
15-14	RES	Reserved locations. Read as ones. Written as zero.
13-12	RCVFW[1:0]	Receive FIFO Watermark. RCVFW controls the point at which ISA bus receive DMA is requested in relation to the number of received bytes in the receive FIFO. RCVFW specifies the number of bytes which must be present (once the frame has been verified as a non-runt) before receive DMA is requested. Note however that in order for receive DMA to be performed for a new frame, at least 64 bytes must have been received. This effectively avoids having to react to receive frames which are runts or suffer a collision during the slot time (512 bit times). If the Runt Packet Accept feature is enabled, receive DMA will be requested as soon as either the RCVFW threshold is reached, or a complete valid receive frame is detected (regardless of length). RCVFW is set to a value of 10b (64 bytes) after RESET. Read/write accessible only when STOP bit is set.

CSR74: Transmit Ring Counter

Bit	Name	Description
15-0	XMTRC	Transmit Ring Counter location. Contains a Two's complement binary number used to number the current transmit descriptor. This counter interprets the value in CSR78 as pointing to the first descriptor; a two's complement value of -1 (FFFFh) corresponds to the last descriptor in the ring. Read/write accessible only when STOP bit is set.

CSR76: Receive Ring Length

Bit	Name	Description
15-0	RCVRL	Receive Ring Length. Contains a Two's complement binary number of the receive descriptor ring length. This register is initialized during the PCnet-ISA controller initialization routine based on the

RCVFW[1:0]	Bytes Received
00	16
01	32
10	64
11	Reserved

11-10XMTSP[1:0] Transmit Start Point. XMTSP controls the point at which preamble transmission attempts commence in relation to the number of bytes written to the transmit FIFO for the current transmit frame. When the entire frame is in the FIFO, transmission will start regardless of the value in XMTSP. XMTSP is given a value of 10b (64 bytes) after RESET. Regardless of XMTSP, the FIFO will not internally overwrite its data until at least 64 bytes (or the entire frame if <64 bytes) have been transmitted onto the network. This ensures that for collisions within the slot time window, transmit data need not be re-written to the transmit FIFO, and re-tries will be handled autonomously by the MAC. This bit is read/write accessible only when the STOP bit is set.

XMTSP[1:0]	Bytes Written
00	4
01	16
10	64
11	112

9-8 XMTFW[1:0] Transmit FIFO Watermark. XMTFW specifies the point at which transmit DMA stops, based upon the number of write cycles that could be performed to the transmit FIFO without FIFO overflow. Transmit DMA is allowed at any time when the number of write cycles specified by XMTFW could be executed without causing transmit FIFO overflow. XMTFW is set to a value of 00b (8 cycles) after hardware RESET. Read/write accessible only when STOP bit is set.

XMTFW[1:0]	Write Cycles
00	8
01	16
10	32
11	Reserved

7-0 DMABR

DMA Burst Register. This register contains the maximum allowable number of transfers to system memory that the Bus Interface will perform during a single DMA cycle. The Burst Register is not used to limit the number of transfers during Descriptor transfers. A value of zero will be interpreted as one transfer. During RESET a value of 16 is loaded in the BURST register. If DMAPLUS (CSR4.14) is set, the DMA Burst Register is disabled.

When the Bus Activity Timer register (CSR82: DMABAT) is enabled, the PCnet-ISA controller will relinquish the bus when either the time specified in DMABAT has elapsed or the number of transfers specified in DMABR have occurred. When ENTST (CSR4.15) is asserted, all writes to this register will automatically perform a decrement cycle.

Read/write accessible only when STOP bit is set.

CSR82: Bus Activity Timer

Bit	Name	Description
15-0	DMABAT	Bus Activity Timer. If the TIMER bit in CSR4 is set, this register contains the maximum allowable time that the PCnet-ISA controller will take up on the system bus during FIFO data transfers in each bus mastership period. The DMABAT starts counting upon receipt of DACK from the host system. The DMABAT Register does not limit the number of transfers during Descriptor transfers. A value of zero will limit the PCnet-ISA controller to one bus cycle per mastership period. A non-zero value is interpreted as an unsigned number with a resolution of 100 ns. For instance, a value of 51 micro seconds would be programmed with a value of 510. When the TIMER bit in CSR4 is set, DMABAT is enabled and must be initialized by the user. The DMABAT register is undefined until written. When the

ENTST bit in CSR4 is set, all writes to this register will automatically perform a decrement cycle.

When the Bus Activity Timer register (CSR82: DMABAT) is enabled, the PCnet-ISA controller will relinquish the bus when either the time specified in DMABAT has elapsed or the number of transfers specified in DMABR have occurred. When ENTST (CSR4.15) is asserted, all writes to this register will automatically perform a decrement cycle.

Read/write accessible only when STOP bit is set.

CSR84-85: DMA Address

Bit	Name	Description
31-0	DMABA	<p>DMA Address Register.</p> <p>This register contains the address of system memory for the current DMA cycle. The Bus Interface Unit controls the Address Register by issuing increment commands to increment the memory address for sequential operations. The DMABA register is undefined until the first PCnet-ISA controller DMA operation. When the ENTST bit in CSR4 is set, all writes to this register will automatically perform an increment cycle.</p> <p>This register has meaning only if the PCnet-ISA controller is in Bus Master Mode.</p> <p>Read/write accessible only when STOP bit is set.</p>

CSR86: Buffer Byte Counter

Bit	Name	Description
15-12	RES	Reserved, Read and written with ones.
11-0	DMABC	<p>DMA Byte Count Register. Contains a Two's complement of the current size of the remaining transmit or receive buffer in bytes. This register is incremented by the Bus Interface Unit. The DMABC register is undefined until written. When ENTST</p>

(CSR4.15) is asserted, all writes to this register will automatically perform an increment cycle.

Read/write accessible only when STOP bit is set.

CSR88-89: Chip ID

Bit	Name	Description
31-28		Version. This 4-bit pattern is silicon revision dependent.
27-12		Part number. The 16-bit code for the PCnet-ISA controller is 0000000000000011b.
11-1		Manufacturer ID. The 11-bit manufacturer code for AMD is 00000000001b. This code is per the JEDEC Publication 106-A.
0		<p>Always a logic 1.</p> <p>This register is exactly the same as the Chip ID register in the JTAG description.</p>

CSR92: Ring Length Conversion

Bit	Name	Description
15-0	RCON	<p>Ring Length Conversion Register. This register performs a ring length conversion from an encoded value as found in the initialization block to a Two's complement value used for internal counting. By writing bits 15-12 with an encoded ring length, a Two's complemented value is read. The RCON register is undefined until written.</p> <p>Read/write accessible only when STOP bit is set.</p>

CSR94: Transmit Time Domain Reflectometry Count

Bit	Name	Description
15-10	RES	Reserved locations. Read and written as zero.
9-0	XMTTDR	<p>Time Domain Reflectometry reflects the state of an internal counter that counts from the start of transmission to the occurrence of loss of carrier. TDR is incremented at a rate of 10 MHz.</p> <p>Read accessible only when STOP bit is set. Write operations are ignored. XMTTDR is cleared by RESET.</p>

CSR96-97: Bus Interface Scratch Register 0

Bit	Name	Description
31-0	SCR0	This register is shared between the Buffer Management Unit and the Bus Interface Unit. All Descriptor Data communications between the BIU and BMU are written and read through SCR0 and SCR1 registers. The SCR0 register is undefined until written. Read/write accessible only when STOP bit is set.

CSR98-99: Bus Interface Scratch Register 1

Bit	Name	Description
31-0	SCR1	This register is shared between the Buffer Management Unit and the Bus Interface Unit. All Descriptor Data communications between the BIU and BMU are written and read through SCR0 and SCR1 registers. Read/write accessible only when STOP bit is set.

CSR104-105: SWAP

Bit	Name	Description
31-0	SWAP	This register performs word and byte swapping depending upon if 32-bit or 16-bit internal write operations are performed. This register is used internally by the BIU/BMU as a word or byte swapper. The swap register can perform 32-bit operations that the PC can not; the register is externally accessible for test reasons only. CSR104 holds the lower 16 bits and CSR105 holds the upper 16 bits. The swap function is defined as follows:

Internal Write Operation	SWAP Register Result
32-Bit word	SRC[31:16] → SWAP[15:0] SRC[15:0] → SWAP[31:16]
Lower 16-Bit (CSR104)	SRC[15:8] → SWAP[7: 0] SRC[7:0] → SWAP[15:8]

Read/write accessible only when STOP bit is set.

CSR108-109: Buffer Management Scratch

Bit	Name	Description
31-0	BMSCR	The Buffer Management Scratch register is used for assembling Receive and Transmit Status. This register is also used as the primary scan register for Buffer Management Test Modes. BMSCR register is undefined until written. Read/write accessible only when STOP bit is set.

CSR112: Missed Frame Count

Bit	Name	Description
15-0	MFC	Counts the number of missed frames. This register is always readable and is cleared by STOP. A write to this register performs an increment when the ENTST bit in CSR4 is set. When MFC is all 1's (65535) and a missed frame occurs, MFC increments to 0 and sets MFC0 bit (CSR4.9).

CSR114: Receive Collision Count

Bit	Name	Description
15-0	RCVCC	Counts the number of Receive collisions seen, regular and late. This register is always readable and is cleared by STOP. A write to this register performs an increment when the ENTST bit in CSR4 is set. When RCVCC is all 1's (65535) and a receive collision occurs, RCVCC increments to 0 and sets RCVCC0 bit (CSR4.5)

CSR124: Buffer Management Unit Test

Bit	Name	Description
		This register is used to place the BMU/BIU into various test modes to support Test/Debug. This register is writeable when the ENTST bit in CSR4 is set.

15-5	RES	Reserved locations. Written as zero and read as undefined.	active. The default value of 5h indicates 250 ns pulse widths. A value of 0 or 1 will generate 50 ns wide commands.
4	GPSIEN	This mode places the PCnet-ISA controller in the GPSI Mode. This mode will reconfigure the External Address Pins so that the GPSI port is exposed. This allows bypassing the MENDEC-TMAU logic. This bit should only be set if the external logic supports GPSI operation. Damage to the device may occur in a non-GPSI configuration. Refer to the GPSI section.	
3	RPA	Runt Packet Accept. This bit forces the CORE receive logic to accept Runt Packets. This bit allows for faster testing.	
2-0	RES	For test purposes only. Reserved locations. Written as zero and read as undefined.	

ISA Bus Configuration Registers

The ISA Bus Data Port (IDP) allows access to registers which are associated with the ISA bus. These registers are called ISA Bus Configuration Registers (ISACSRs), and are indexed by the value in the Register Address Port (RAP). The table below defines the ISACSRs which can be accessed. All registers are 16 bits. The "Default" value is the value in the register after reset and is hexadecimal.

ISACSR	MNEMONIC	Default	Name
0	MSRDA	0005H	Master Mode Read Active
1	MSWRA	0005H	Master Mode Write Active
2	MC	0002H	Miscellaneous Configuration
3	Reserved	N/A	Reserved for future AMD use
4	LED0	0000H	Link Integrity
5	LED1	0084H	Default: RCV
6	LED2	0008H	Default: RCVPOL
7	LED3	0090H	Default: XMT

ISACSR0: Master Mode Read Active

Bit	Name	Description
15-4	RES	Reserved locations. Written as zero and read as undefined.
3-0	MSRDA	This register is used to tune the MEMR command signal active time. The value stored in MSRDA defines the number of 50 ns periods that the command signal is

ISACSR1: Master Mode Write Active

Bit	Name	Description
15-4	RES	Reserved locations. Written as zero and read as undefined.
3-0	MSWRA	This register is used to tune the MEMW command signal active time. The value stored in MSWRA defines the number of 50 ns periods that the command signal is active. The default value of 5h indicates 250 ns pulse widths. A value of 0 or 1 will generate 50 ns wide commands.

ISACSR2: Miscellaneous Configuration

Bit	Name	Description
15	MODE_STATUS	Mode Status. This is a read-only register which indicates whether the PCnet-ISA is configured in shared memory mode. A set condition indicates shared-memory while a clear condition indicates bus-master condition.
14-8	RES	Reserved locations. Written and read as zero.
7	EISA_LVL	EISA_LVL allows for EISA level-sensitive interrupt support. EISA_LVL is cleared when RESET is asserted. When EISA_LVL is a zero, the IRQ pin is configured for ISA edge sensitive full CMOS driver. When EISA_LVL is set by writing a one, the IRQ pin is configured as an EISA level-sensitive interrupt open drain output. When EISA_LVL is set to one, the IRQ pin assertion level is active low.
6-5	RES	Reserved locations. Written and read as zero.
4	ISAINACT	ISAINACT allows for reduced inactive timing appropriate for modern ISA machines. ISAINACT is cleared when RESET is asserted. When ISAINACT is a zero, tMMR3 and tMMW3 parameters are nominally 200 ns, which is compatible with EISA system. When ISAINACT is set by writing a one,

3	EADISEL	tMMR3 and tMMW3 are nominally set to 100 ns. EADI Select. Enables EADI match mode. XMAUSEL must be 0.	14-0	RES	Link Status LED is asserted, indicating good 10BASE-T integrity. Reserved locations. Written as 0, read as undefined.
2	AWAKE	Auto-Wake. If LNKST is set and AWAKE = "1", the 10BASE-T receive circuitry is active during sleep and listens for Link Pulses. LED0 indicates Link Status and goes active if the 10BASE-T port comes out of "link fail" state. This LED0 pin can be used by external circuitry to re-enable the PCnet-ISA controller and/or other devices. When AWAKE = "0", the Auto-Wake circuitry is disabled. This bit only has meaning when the 10BASE-T network interface is selected.	ISACSR5: LED1 Status		
1	ASEL	Auto Select. When set, the PCnet-ISA controller will automatically select the operating media interface port. Set by Reset.	15	LEDOUT	ISACSR5 controls the function(s) that the LED1 pin displays. Multiple functions can be simultaneously enabled on this LED pin. The LED display will indicate the logical OR of the enabled functions. ISACSR5 defaults to Receive Status (RCV) with pulse stretcher enabled (PSE = 1) and is fully programmable. Indicates the current (non-stretched) state of the function(s) generated. Read only.
0	XMAUSEL	External MAU Select allows the hardware selection of AUI or 10BASE-T interfaces when set. When cleared, the interface is selected by software. Cleared by RESET.	14-8	RES	Reserved locations. Read and written as zero.
			7	PSE	Pulse Stretcher Enable. Extends the LED illumination for each enabled function occurrence. 0 is disabled, 1 is enabled.
			6-5	RES	Reserved locations. Read and written as zero.
			4	XMT E	Enable Transmit Status Signal. Indicates PCnet-ISA controller transmit activity . 0 disables the signal, 1 enables the signal.
			3	RVPOL E	Enable Receive Polarity Signal. Enables LED pin assertion when receive polarity is correct on the 10BASE-T port. Clearing the bit indicates this function is to be ignored.
			2	RCV E	Enable Receive Status Signal. Indicates receive activity on the network. 0 disables the signal, 1 enables the signal.
			1	JAB E	Enable Jabber Signal. Indicates the PCnet-ISA controller is jabbering on the network. 0 disables the signal, 1 enables the signal.
			0	COL E	Enable Collision Signal. Indicates collision activity on the network. 0 disables the signal, 1 enables the signal.

ASEL (Bit 1)	XMAUSEL (Bit 0)	Selection Mode
0	0	Software; interface selection is done through the PORTSEL[1:0] bits in CSR15.
0	1	Jumper; interface selection is done through the MAUSEL pin.
1	0	Automatic (default)
1	1	Reserved

ISACSR4: LED0 Status (Link Integrity)

Bit	Name	Description
15	LNKST	ISACSR4 is a non-programmable register that uses one bit to reflect the status of the LED0 pin. This pin defaults to twisted pair MAU Link Status (LNKST) and is not programmable. LNKST is a read-only register bit that indicates whether the Link Status LED is asserted. When LNKST is read as zero, the Link Status LED is not asserted. When LNKST is read as one, the

ISACSR6: LED2 Status
ISACSR7: LED3 Status

Bit	Name	Description
		ISACSR6 controls the function(s) that the LED2 pin displays. Multiple functions can be simultaneously enabled on this LED pin. The LED display will indicate the logical OR of the enabled functions. ISACSR6 defaults to twisted pair MAU Receive Polarity (RCVPOL) with pulse stretcher enabled (PSE = 1) and is fully programmable.
15	LEDOUT	Indicates the current (non-stretched) state of the function(s) generated. Read only.
14-8	RES	Reserved locations. Read and written as zero.
7	PSE	Pulse Stretcher Enable. Extends the LED illumination for each enabled function occurrence. 0 is disabled, 1 is enabled.
6-5	RES	Reserved locations. Read and written as zero.
4	XMT E	Enable Transmit Status Signal. Indicates PCnet-ISA controller transmit activity . 0 disables the signal, 1 enables the signal.
3	RVPOL E	Enable Receive Polarity Signal. Enables LED pin assertion when receive polarity is correct on the 10BASE-T port. Clearing the bit indicates this function is to be ignored.
2	RCV E	Enable Receive Status Signal. Indicates receive activity on the network. 0 disables the signal, 1 enables the signal.
1	JAB E	Enable Jabber Signal. Indicates the PCnet-ISA controller is jabbering on the network. 0 disables the signal, 1 enables the signal.
0	COL E	Enable Collision Signal. Indicates collision activity on the network. 0 disables the signal, 1 enables the signal.

Bit	Name	Description
		ISACSR7 controls the function(s) that the LED3 pin displays. Multiple functions can be simultaneously enabled on this LED pin. The LED display will indicate the logical OR of the enabled functions. ISACSR7 defaults to Transmit Status (XMT) with pulse stretcher enabled (PSE = 1) and is fully programmable.
15	LEDOUT	Indicates the current (non-stretched) state of the function(s) generated. Read only.
14-8	RES	Reserved locations. Read and written as zero.
7	PSE	Pulse Stretcher Enable. Extends the LED illumination for each enabled function occurrence. 0 is disabled, 1 is enabled.
6-5	RES	Reserved locations. Read and written as zero.
4	XMT E	Enable Transmit Status Signal. Indicates PCnet-ISA controller transmit activity . 0 disables the signal, 1 enables the signal.
3	RVPOL E	Enable Receive Polarity Signal. Enables LED pin assertion when receive polarity is correct on the 10BASE-T port. Clearing the bit indicates this function is to be ignored.
2	RCV E	Enable Receive Status Signal. Indicates receive activity on the network. 0 disables the signal, 1 enables the signal.
1	JAB E	Enable Jabber Signal. Indicates the PCnet-ISA controller is jabbering on the network. 0 disables the signal, 1 enables the signal.
0	COL E	Enable Collision Signal. Indicates collision activity on the network. 0 disables the signal, 1 enables the signal.

Initialization Block

The figure below shows the Initialization Block memory configuration. Note that the Initialization Block must be based on a word (16-bit) boundary.

Address	Bits 15–12	Bits 11–8	Bits 7–4	Bits 3–0
IADR+22	TLEN	RES	TDRA 23–16	
IADR+20	TDRA 15–00			
IADR+18	RLEN	RES	RDRA 23–16	
IADR+16	RDRA 15–00			
IADR+14	LADRF 63–48			
IADR+12	LADRF 47–32			
IADR+10	LADRF 31–16			
IADR+08	LADRF 15–00			
IADR+06	PADR 47–32			
IADR+04	PADR 31–16			
IADR+02	PADR 15–00			
IADR+00	MODE 15–00			

RLEN and TLEN

The TLEN and RLEN fields in the initialization block are 3 bits wide, occupying bits 15, 14, and 13, and the value in these fields determines the number of Transmit and Receive Descriptor Ring Entries (DRE) which are used in the descriptor rings. Their meaning is as follows:

R/TLEN	# of DREs
000	1
001	2
010	4
011	8
100	16
101	32
110	64
111	128

If a value other than those listed in the above table is desired, CSR76 and CSR78 can be written after initialization is complete. See the description of the appropriate CSRs.

RDRA and TDRA

TDRA and RDRA indicate where the transmit and receive descriptor rings, respectively, begin. Each DRE must be located on an 8-byte boundary.

LADRF

The Logical Address Filter (LADRF) is a 64-bit mask that is used to accept incoming Logical Addresses. If the first bit in the incoming address (as transmitted on the wire) is a “1”, the address is deemed logical. If the first bit is a “0”, it is a physical address and is compared against the physical address that was loaded through the initialization block.

A logical address is passed through the CRC generator, producing a 32-bit result. The high order 6 bits of the CRC are used to select one of the 64 bit positions in the Logical Address Filter. If the selected filter bit is set, the address is accepted and the frame is placed into memory.

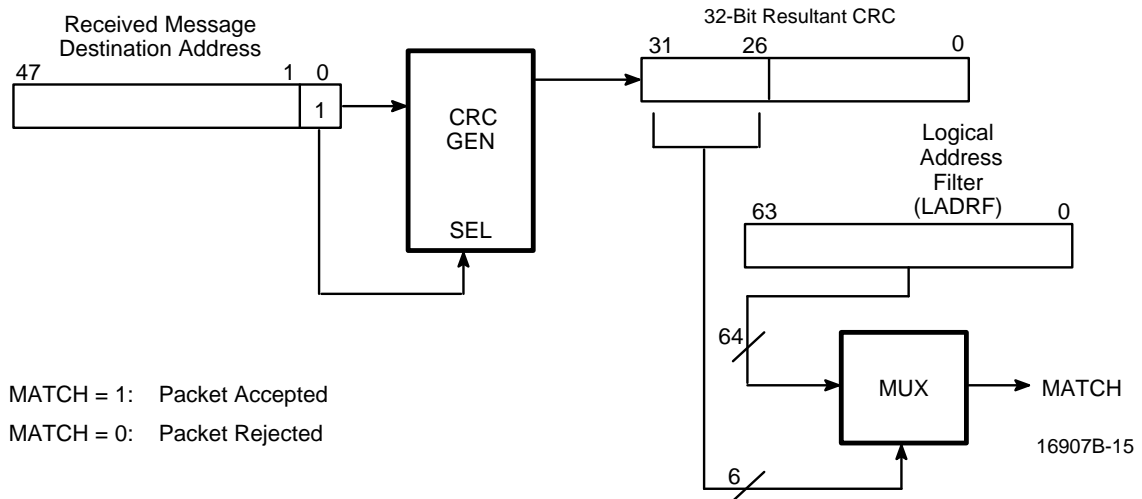

Address Match Logic

The Logical Address Filter is used in multicast addressing schemes. The acceptance of the incoming frame based on the filter value indicates that the message may be intended for the node. It is the node's responsibility to determine if the message is actually intended for the node by comparing the destination address of the stored message with a list of acceptable logical addresses.

If the Logical Address Filter is loaded with all zeroes and promiscuous mode is disabled, all incoming logical addresses except broadcast will be rejected.

The Broadcast address, which is all ones, does not go through the Logical Address Filter and is handled as follows:

- 1) If the Disable Broadcast Bit is cleared, the broadcast address is accepted.
- 2) If the Disable Broadcast Bit is set and promiscuous mode is enabled, the broadcast address is accepted.
- 3) If the Disable Broadcast Bit is set and promiscuous mode is disabled, the broadcast address is rejected.

If external loopback is used, the FCS logic must be allocated to the receiver (by setting the DXMTFCS bit in CSR15, and clearing the ADD_FCS bit in TMD1) when using multicast addressing.

PADR

This 48-bit value represents the unique node address assigned by the IEEE and used for internal address comparison. PADR[0] is the first address bit transmitted on the wire, and must be zero. The six-byte nomenclature used by the IEEE maps to the PCnet-ISA controller PADR register as follows: the first byte comprises PADR[7:0], with PADR[0] being the least significant bit of the byte. The second IEEE byte maps to PADR[15:8], again from LSbit to MSbit, and so on. The sixth byte maps to PADR[47:40], the LSbit being PADR[40].

MODE

The mode register in the initialization block is copied into CSR15 and interpreted according to the description of CSR15.

Receive Descriptors

The Receive Descriptor Ring Entries (RDREs) are composed of 4 receive message fields (RMD0-3). Together they contain the following information:

- The address of the actual message data buffer in user (host) memory.
- The length of that message buffer.
- Status information indicating the condition of the buffer. The eight most significant bits of RMD1 (RMD1[15:0]) are collectively termed the STATUS of the receive descriptor.

RMD0

Holds LADR [15:0]. This is combined with HADR [7:0] in RMD1 to form the 24-bit address of the buffer pointed to by this descriptor table entry. There are no restrictions on buffer byte alignment or length.

RMD1

Bit	Name	Description
15	OWN	This bit indicates that the descriptor entry is owned by the host (OWN=0) or by the PCnet-ISA controller (OWN=1). The PCnet-ISA controller clears the OWN bit after filling the buffer pointed to by the descriptor entry. The host sets the OWN bit after emptying the buffer. Once the PCnet-ISA controller or host has relinquished ownership of a

		buffer, it must not change any field in the descriptor entry.	8	ENP	END OF PACKET indicates that this is the last buffer used by the PCnet-ISA controller for this frame. It is used for data chaining buffers. If both STP and ENP are set, the frame fits into one buffer and there is no data chaining. ENP is written by the PCnet-ISA controller.									
14	ERR	ERR is the OR of FRAM, OFLO, CRC, or BUFF. ERR is written by the PCnet-ISA controller.												
13	FRAM	FRAMING ERROR indicates that the incoming frame contained a non-integer multiple of eight bits and there was an FCS error. If there was no FCS error on the incoming frame, then FRAM will not be set even if there was a non integer multiple of eight bits in the frame. FRAM is not valid in internal loopback mode. FRAM is valid only when ENP is set and OFLO is not. FRAM is written by the PCnet-ISA controller.	7-0	HADR	The HIGH ORDER 8 address bits of the buffer pointed to by this descriptor. This field is written by the host and is not changed by the PCnet-ISA controller.									
RMD2														
<table border="1"> <thead> <tr> <th>Bit</th> <th>Name</th> <th>Description</th> </tr> </thead> <tbody> <tr> <td>15-12</td> <td>ONES</td> <td>MUST BE ONES. This field is written by the host and unchanged by the PCnet-ISA controller.</td> </tr> <tr> <td>11-0</td> <td>BCNT</td> <td>BUFFER BYTE COUNT is the length of the buffer pointed to by this descriptor, expressed as the two's complement of the length of the buffer. This field is written by the host and is not changed by the PCnet-ISA controller.</td> </tr> </tbody> </table>						Bit	Name	Description	15-12	ONES	MUST BE ONES. This field is written by the host and unchanged by the PCnet-ISA controller.	11-0	BCNT	BUFFER BYTE COUNT is the length of the buffer pointed to by this descriptor, expressed as the two's complement of the length of the buffer. This field is written by the host and is not changed by the PCnet-ISA controller.
Bit	Name	Description												
15-12	ONES	MUST BE ONES. This field is written by the host and unchanged by the PCnet-ISA controller.												
11-0	BCNT	BUFFER BYTE COUNT is the length of the buffer pointed to by this descriptor, expressed as the two's complement of the length of the buffer. This field is written by the host and is not changed by the PCnet-ISA controller.												
12	OFLO	OVERFLOW error indicates that the receiver has lost all or part of the incoming frame, due to an inability to store the frame in a memory buffer before the internal FIFO overflowed. OFLO is valid only when ENP is not set. OFLO is written by the PCnet-ISA controller.												
11	CRC	CRC indicates that the receiver has detected a CRC (FCS) error on the incoming frame. CRC is valid only when ENP is set and OFLO is not. CRC is written by the PCnet-ISA controller.												
RMD3														
<table border="1"> <thead> <tr> <th>Bit</th> <th>Name</th> <th>Description</th> </tr> </thead> <tbody> <tr> <td>15-12</td> <td>RES</td> <td>RESERVED and read as zeros.</td> </tr> <tr> <td>11-0</td> <td>MCNT</td> <td>MESSAGE BYTE COUNT is the length in bytes of the received message, expressed as an unsigned binary integer. MCNT is valid only when ERR is clear and ENP is set. MCNT is written by the PCnet-ISA controller and cleared by the host.</td> </tr> </tbody> </table>						Bit	Name	Description	15-12	RES	RESERVED and read as zeros.	11-0	MCNT	MESSAGE BYTE COUNT is the length in bytes of the received message, expressed as an unsigned binary integer. MCNT is valid only when ERR is clear and ENP is set. MCNT is written by the PCnet-ISA controller and cleared by the host.
Bit	Name	Description												
15-12	RES	RESERVED and read as zeros.												
11-0	MCNT	MESSAGE BYTE COUNT is the length in bytes of the received message, expressed as an unsigned binary integer. MCNT is valid only when ERR is clear and ENP is set. MCNT is written by the PCnet-ISA controller and cleared by the host.												
10	BUFF	BUFFER ERROR is set any time the PCnet-ISA controller does not own the next buffer while data chaining a received frame. This can occur in either of two ways: <ol style="list-style-type: none"> 1) The OWN bit of the next buffer is zero. 2) FIFO overflow occurred before the PCnet-ISA controller polled the next descriptor. <p>If a Buffer Error occurs, an Overflow Error may also occur internally in the FIFO, but will not be reported in the descriptor status entry unless both BUFF and OFLO errors occur at the same time. BUFF is written by the PCnet-ISA controller.</p>												
9	STP	START OF PACKET indicates that this is the first buffer used by the PCnet-ISA controller for this frame. It is used for data chaining buffers. STP is written by the PCnet-ISA controller.												

Transmit Descriptors

The Transmit Descriptor Ring Entries (TDREs) are composed of 4 transmit message fields (TMD0-3). Together they contain the following information:

- The address of the actual message data buffer in user or host memory.
- The length of the message buffer.
- Status information indicating the condition of the buffer. The eight most significant bits of TMD1 (TMD1[15:8]) are collectively termed the STATUS of the transmit descriptor.

Note that bit 13 of TMD1, which was formerly a reserved bit in the LANCE (Am7990), is assigned a new meaning, ADD_FCS.

TMD0

Holds LADRF [15:0]. This is combined with HADR [7:0] in TMD1 to form a 24-bit address of the buffer pointed to by this descriptor table entry. There are no restrictions on buffer byte alignment or length.

TMD1

Bit	Name	Description
15	OWN	This bit indicates that the descriptor entry is owned by the host (OWN=0) or by the PCnet-ISA controller (OWN=1). The host sets the OWN bit after filling the buffer pointed to by the descriptor entry. The PCnet-ISA controller clears the OWN bit after transmitting the contents of the buffer. Both the PCnet-ISA controller and the host must not alter a descriptor entry after it has relinquished ownership.
14	ERR	ERR is the OR of UFLO, LCOL, LCAR, or RTRY. ERR is written by the PCnet-ISA controller. This bit is set in the current descriptor when the error occurs, and therefore may be set in any descriptor of a chained buffer transmission.
13	ADD_FCS	ADD_FCS dynamically controls the generation of FCS on a frame by frame basis. It is valid only if the STP bit is set. When ADD_FCS is set, the state of DXMTFCS is ignored and transmitter FCS generation is activated. When ADD_FCS = 0, FCS generation is controlled by DXMTFCS. ADD_FCS is written by the host, and unchanged by the PCnet-ISA controller. This was a reserved bit in the LANCE (Am7990).
12	MORE	MORE indicates that more than one re-try was needed to transmit a frame. MORE is written by the PCnet-ISA controller. This bit has meaning only if the ENP or the ERR bit is set.
11	ONE	ONE indicates that exactly one re-try was needed to transmit a frame. ONE flag is not valid when LCOL is set. ONE is written by the PCnet-ISA controller. This bit

10	DEF	DEFERRED indicates that the PCnet-ISA controller had to defer while trying to transmit a frame. This condition occurs if the channel is busy when the PCnet-ISA controller is ready to transmit. DEF is written by the PCnet-ISA controller. This bit has meaning only if the ENP or ERR bits are set.
9	STP	START OF PACKET indicates that this is the first buffer to be used by the PCnet-ISA controller for this frame. It is used for data chaining buffers. The STP bit must be set in the first buffer of the frame, or the PCnet-ISA controller will skip over the descriptor and poll the next descriptor(s) until the OWN and STP bits are set. STP is written by the host and is not changed by the PCnet-ISA controller.
8	ENP	END OF PACKET indicates that this is the last buffer to be used by the PCnet-ISA controller for this frame. It is used for data chaining buffers. If both STP and ENP are set, the frame fits into one buffer and there is no data chaining. ENP is written by the host and is not changed by the PCnet-ISA controller.
7-0	HADR	The HIGH ORDER 8 address bits of the buffer pointed to by this descriptor. This field is written by the host and is not changed by the PCnet-ISA controller.

TMD2

Bit	Name	Description
15-12	ONES	MUST BE ONES. This field is written by the host and unchanged by the PCnet-ISA controller.
11-0	BCNT	BUFFER BYTE COUNT is the length of the buffer pointed to by this descriptor, expressed as the two's complement of the length of the buffer. This is the number of bytes from this buffer that will be transmitted by the PCnet-ISA controller. This field is written by the host and is not changed by

Bit	Name	Description			
		the PCnet-ISA controller. There are no minimum buffer size restrictions. Zero length buffers are allowed for protocols which require it.	12	LCOL	LATE COLLISION indicates that a collision has occurred after the slot time of the channel has elapsed. The PCnet-ISA controller does not re-try on late collisions. LCOL is written by the PCnet-ISA controller.
TMD3					
			11	LCAR	LOSS OF CARRIER is set when the carrier is lost during an PCnet-ISA controller-initiated transmission. The PCnet-ISA controller does not stop transmission upon loss of carrier. It will continue to transmit the whole frame until done. LCAR is written by the PCnet-ISA controller.
15	BUFF	<p>BUFFER ERROR is set by the PCnet-ISA controller during transmission when the PCnet-ISA controller does not find the ENP flag in the current buffer and does not own the next buffer. This can occur in either of two ways:</p> <ol style="list-style-type: none"> 1) The OWN bit of the next buffer is zero. 2) FIFO underflow occurred before the PCnet-ISA controller obtained the next STATUS byte (TMD1[15:8]). <p>BUFF error will turn off the transmitter (CSR0, TXON = 0). If a Buffer Error occurs, an Underflow Error will also occur. BUFF is not valid when LCOL or RTRY error is set during transmit data chaining. BUFF is written by the PCnet-ISA controller.</p>	10	RTRY	RETRY ERROR indicates that the transmitter has failed after 16 attempts to successfully transmit a message, due to repeated collisions on the medium. If DRTY = 1 in the MODE register, RTRY will set after one failed transmission attempt. RTRY is written by the PCnet-ISA controller.
			09-00	TDR	<p>TIME DOMAIN REFLECTOMETRY reflects the state of an internal PCnet-ISA controller counter that counts at a 10 MHz rate from the start of a transmission to the occurrence of a collision or loss of carrier. This value is useful in determining the approximate distance to a cable fault. The TDR value is written by the PCnet-ISA controller and is valid only if RTRY is set.</p> <p>Note that 10 MHz gives very low resolution and in general has not been found to be particularly useful. This feature is here primarily to maintain full compatibility with the LANCE.</p>
14	UFLO	UNDERFLOW ERROR indicates that the transmitter has truncated a message due to data late from memory. UFLO indicates that the FIFO has emptied before the end of the frame was reached. Upon UFLO error, the transmitter is turned off (CSR0, TXON = 0). UFLO is written by the PCnet-ISA controller.			
13	RES	RESERVED bit. The PCnet-ISA controller will write this bit with a "0".			

Register Summary
Ethernet Controller Registers (accessed via RDP port)

RAP Addr	Symbol	Width	User Register	Comments
00	CSR0	16-bit	Y	PCnet-ISA Controller Status
01	CSR1	16-bit	Y	Lower IADR: maps to location 16
02	CSR2	16-bit	Y	Upper IADR: maps to location 17
03	CSR3	16-bit	Y	Mask Register
04	CSR4	16-bit	Y	Miscellaneous Register
05	CSR5	16-bit		Reserved
06	CSR6	16-bit		RCV/XMT Descriptor Table Length
07	CSR7	16-bit		Reserved
08	CSR8	16-bit	Y	LADR0: LADRF[15:0]
09	CSR9	16-bit	Y	LADR1: LADRF[31:16]
10	CSR10	16-bit	Y	LADR2: LADRF[47:32]
11	CSR11	16-bit	Y	LADR3: LADRF[63:48]
12	CSR12	16-bit	Y	PADR0: PADR[15:0]
13	CSR13	16-bit	Y	PADR1: PADR[31:16]
14	CSR14	16-bit	Y	PADR2: PADR[47:32]
15	CSR15	16-bit	Y	MODE: Mode Register
16–17	CSR16	32-bit		IADR: Base Address of INIT Block
18–19	CSR18	32-bit		CRBA: Current RCV Buffer Address
20–21	CSR20	32-bit		CXBA: Current XMT Buffer Address
22–23	CSR22	32-bit		NRBA: Next RCV Buffer Address
24–25	CSR24	32-bit	Y	BADR: Base Address of RCV Ring
26–27	CSR26	32-bit		NRDA: Next RCV Descriptor Address
28–29	CSR28	32-bit		CRDA: Current RCV Descriptor Address
30–31	CSR30	32-bit	Y	BADX: Base Address of XMT Ring
32–33	CSR32	32-bit		NXDA: Next XMT Descriptor Address
34–35	CSR34	32-bit		CXDA: Current XMT Descriptor Address
36–37	CSR36	32-bit		Next Next Receive Descriptor Address
38–39	CSR38	32-bit		Next Next Transmit Descriptor Address
40–41	CSR40	32-bit		CRBC: Current RCV Stat and Byte Count
42–43	CSR42	32-bit		CXBC: Current XMT Status and Byte Count
44–45	CSR44	32-bit		NRBC: Next RCV Stat and Byte Count
46	CSR46	16-bit		POLL: Poll Time Counter
47	CSR47	32-bit		Polling Interval
48–49	CSR48	32-bit		TMP0: Temporary Storage
50–51	CSR50	32-bit		TMP1: Temporary Storage
52–53	CSR52	32-bit		TMP2: Temporary Storage
54–55	CSR54	32-bit		TMP3: Temporary Storage
56–57	CSR56	32-bit		TMP4: Temporary Storage
58–59	CSR58	32-bit		TMP5: Temporary Storage
60–61	CSR60	32-bit		PXDA: Previous XMT Descriptor Address
62–63	CSR62	32-bit		PXBC: Previous XMT Status and Byte Count

Register Summary**Ethernet Controller Registers (accessed via RDP port) (continued)**

RAP Addr	Symbol	Width	User Registers	Comments
64–65	CSR64	32-bit		NXBA: Next XMT Buffer Address
66–67	CSR66	32-bit		NXBC: Next XMT Status and Byte Count
68–69	CSR68	32-bit		XSTMP: XMT Status Temporary
70–71	CSR70	32-bit		RSTMP: RCV Status Temporary
72	CSR72	16-bit		RCVRC: RCV Ring Counter
74	CSR74	16-bit		XMTRC: XMT Ring Counter
76	CSR76	16-bit	Y	RCVRL: RCV Ring Length
78	CSR78	16-bit	Y	XMTRL: XMT Ring Length
80	CSR80	16-bit	Y	DMABR: Burst Register
82	CSR82	16-bit	Y	DMABAT: Bus Activity Timer
84–85	CSR84	32-bit		DMABA: Address Register
86	CSR86	16-bit		DMABC: Byte Counter/Register
88–89	CSR88	32-bit	Y	Chip ID Register
92	CSR92	16-bit		RCON: Ring Length Conversion Register
94	CSR94	16-bit		XMTTDR: Transmit Time Domain Reflectometry
96–97	CSR96	32-bit		SCR0: BIU Scratch Register 0
98–99	CSR98	32-bit		SCR1: BIU Scratch Register 1
104–105	CSR104	32-bit		SWAP: 16-bit word/byte Swap Register
108–109	CSR108	32-bit		BMSCR: BMU Scratch Register
112	CSR112	16-bit	Y	Missed Frame Count
114	CSR114	16-bit	Y	Receive Collision Count
124	CSR124	16-bit	Y	BMU Test Register
126	CSR126	16-bit		Reserved

Note:

Although the PCnet-ISA controller has many registers that can be accessed by software, most of these registers are intended for debugging and production testing purposes only. The registers with a "Y" are the only registers that should be accessed by network software.

Register Summary
ISACSR—ISA Bus Configuration Registers (accessed via IDP port)

RAP Addr	Mnemonic	Default	Name
0	MSRDA	0005H	Master Mode Read Active
1	MSWRA	0005H	Master Mode Write Active
2	MC	0002H	Miscellaneous Configuration
3	Reserved	N/A	Reserved for future AMD use
4	LED0	0000H	$\overline{\text{LED0}}$ Status (Link Integrity)
5	LED1	0084H	$\overline{\text{LED1}}$ Status (Default: RCV)
6	LED2	0008H	$\overline{\text{LED2}}$ Status (Default: RCVPOL)
7	LED3	0090H	$\overline{\text{LED3}}$ Status (Default: XMT)

I/O Address Offset

Offset	#Bytes	Register
0h	16	Address PROM
10h	2	RDP
12h	2	RAP (shared by RDP and IDP)
14h	2	Reset
16h	2	IDP

SYSTEM APPLICATION

ISA Bus Interface

Compatibility Considerations

Although 8 MHz is now widely accepted as the standard speed at which to run the ISA bus, many machines have been built which operate at higher speeds with non-standard timing. Some machines do not correctly support 16-bit I/O operations with wait states. Although the PCnet-ISA controller is quite fast, some operations still require an occasional wait state. The PCnet-ISA controller moves data through memory accesses, therefore, I/O operations do not affect performance. By configuring the PCnet-ISA controller as an 8-bit I/O device, compatibility with PC/AT-class machines is obtained at virtually no cost in performance. To treat the PCnet-ISA controller as an 8-bit software resource (for non-ISA applications), the even-byte must be accessed first, followed by an odd-byte access.

Memory cycle timing is an area where some tradeoffs may be necessary. Any slow down in a memory cycle translates directly into lower bandwidth. The PCnet-ISA controller starts out with much higher bandwidth than most slave type controllers and should continue to be superior even if an extra 50 or 100 ns are added to memory cycles.

The memory cycle active time is tunable in 50 ns increments with a default of 250 ns. The memory cycle idle time defaults to 200 ns and can be reprogrammed to 100 ns. See register description for ISACS42. Most machines should not need tuning.

The PCnet-ISA controller is compatible with NE2100 and NE1500T software drivers. All the resources such as address PROM, boot PROM, RAP, and RDP are in the same location with the same semantics. An addi-

tional set of registers (ISA CSR) is available to configure on board resources such as ISA bus timing and LED operation. However, loopback frames for the PCnet-ISA controller must contain more than 64 bytes of data if the Runt Packet Accept feature is not enabled; this size limitation does not apply to LANCE (Am7990) based boards such as the NE2100 and NE1500T.

Bus Master

Bus Master mode is the preferred mode for client applications on PC/AT or similar machines supporting 16-bit DMA with its unsurpassed combination of high performance and low cost.

Shared Memory

The shared memory mode is recommended for file servers or other applications where there is very high, average or peak latency.

The address compare circuit has the following functions. It receives the 7 LA signals, generates $\overline{\text{MEMCS16}}$, and compares them to the desired shared memory and boot PROM addresses. The logic latches the address compare result when $\overline{\text{BALE}}$ goes inactive and uses this result along with $\overline{\text{REF}}$ (must be deasserted) and the appropriate SA signals to generate $\overline{\text{SMAM}}$ and $\overline{\text{BPAM}}$.

All these functions can be performed in one PAL device. Assume both memories are 8 Kbytes and are in the same 128 Kbyte region. SA16,15,14,13 are required to select 8 Kbytes, and there are 7 LA pins. Counting the $\overline{\text{MEMCS16}}$ pin, the latched compare pin, four SA pins, the $\overline{\text{REF}}$ pin, the $\overline{\text{SMAM}}$ pin and the $\overline{\text{BPAM}}$ pin, we find a total of 16 pins which can easily fit into one PAL device. To operate in an 8-bit PC/XT environment, the LA signals should have weak pull-down resistors connected to them to present a logic 0 level when not driven.

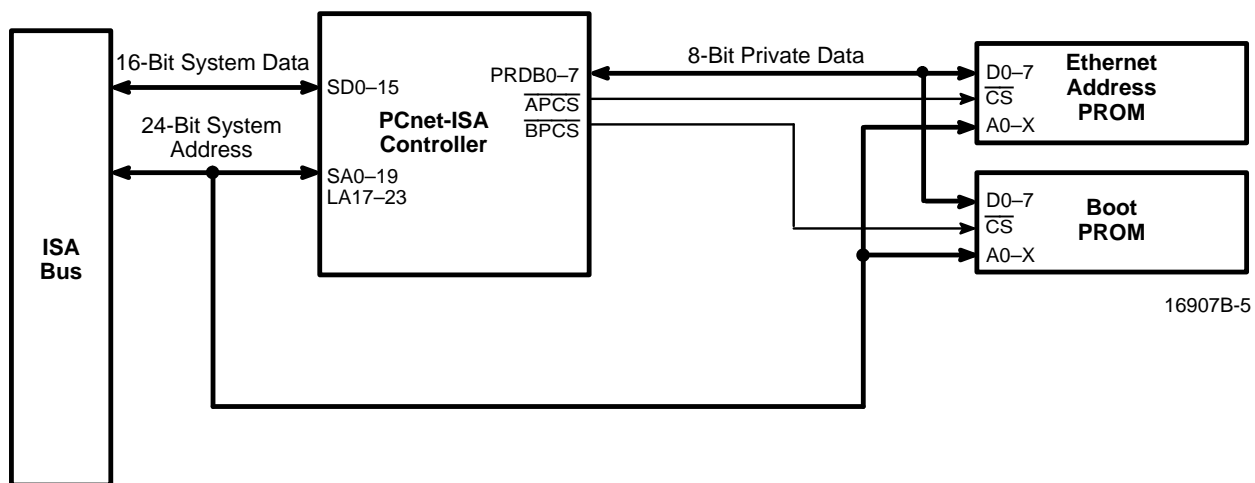

Bus Master Block Diagram

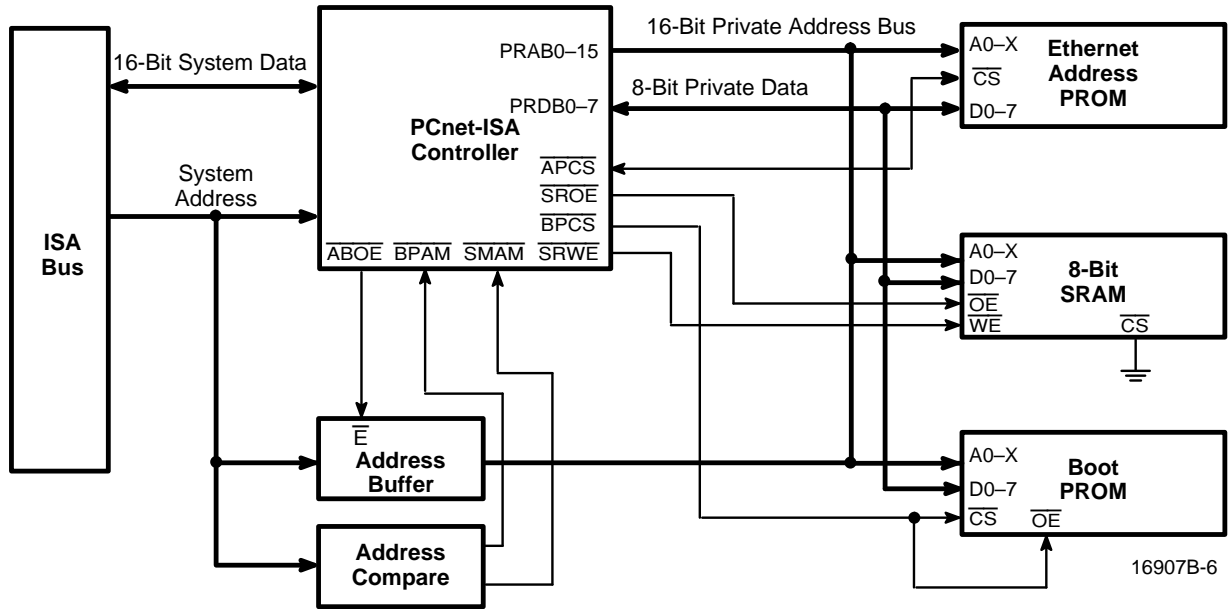

Shared Memory Block Diagram

Address PROM Interface

The suggested address PROM is the Am27LS19, a 32x8 device. APCS should be connected directly to the device's \overline{G} input.

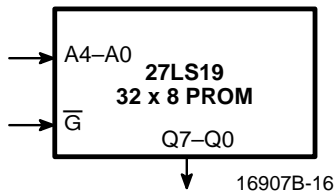

Address PROM Example

Boot PROM Interface

The boot PROM is a 16Kx8 EPROM. Its program pin \overline{P} should be tied to V_{CC} , output enable \overline{OE} tied to ground, and chip enable \overline{CE} to BPCS to minimize power consumption at the expense of speed. If speed is more important, then ground \overline{CE} and connect \overline{OE} to BPCS.

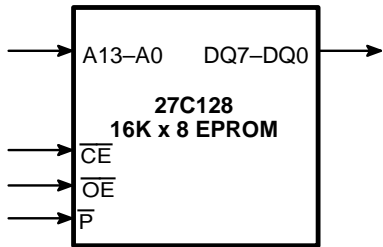

Boot PROM Example

Static RAM Interface (for Shared Memory only)

The SRAM is an 8Kx8 or 32Kx8 device. The PCnet-ISA controller can support 64 Kbytes of SRAM address space. The PCnet-ISA controller provides \overline{SROE} and \overline{SRWE} outputs which can go directly to the \overline{OE} and \overline{WE} pins of the SRAM, respectively. The address lines are connected as described in the shared memory section and the data lines go to the Private Data Bus.

AUI

The PCnet-ISA controller drives the AUI interface through a set of transformers. The DI and CI inputs should each be terminated with a pair of matched 39 Ω or 40.2 Ω resistors connected in series with the middle node bypassed to ground with a .01 μF to 0.1 μF capacitor. Refer to the PCnet-ISA Technical Manual (PID #16850B) for network interface design and refer to Appendix A for a list of compatible AUI isolation transformers.

10BASE-T Interface

The diagram below shows the proper 10BASE-T network interface design. Refer to the PCnet-Family

Technical Manual (PID #18216A) for more design details, and refer to Appendix A for a list of compatible 10BASE-T filter/transformer modules.

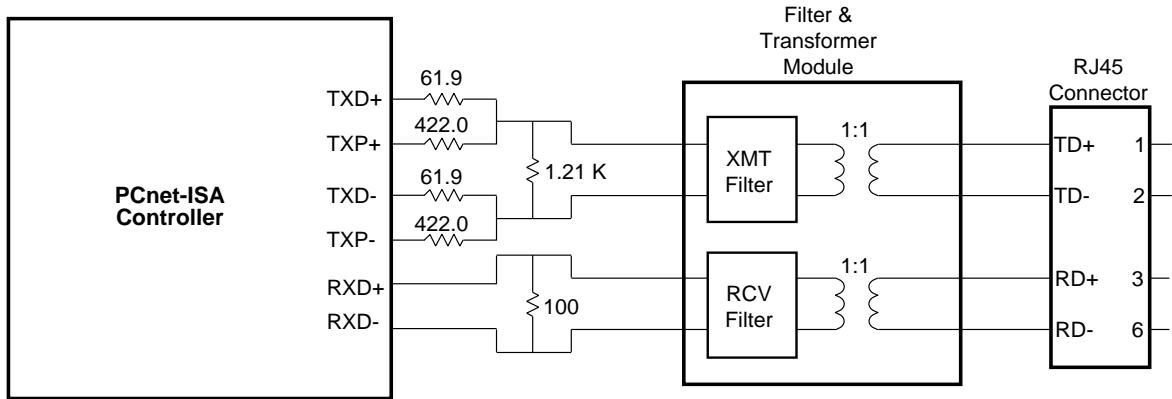

Note:

All resistors are $\pm 1\%$

16907B-18

10BASE-T External Components and Hookup

ABSOLUTE MAXIMUM RATINGS

Storage Temperature -65°C to +150°C
 Ambient Temperature
 Under Bias 0°C to +70°C
 Supply Voltage to AV_{SS}
 or DV_{SS} (AV_{DD}, DV_{DD}) -0.3 V to +6.0 V

Stresses above those listed under Absolute Maximum Ratings may cause permanent device failure. Functionality at or above these limits is not implied. Exposure to Absolute Maximum Ratings for extended periods may affect device reliability. Programming conditions may differ.

OPERATING RANGES

Commercial (C) Devices

Temperature (T_A) 0°C to +70°C
 Supply Voltages
 (AV_{DD}, DV_{DD}) 5 V ±5%
 All inputs within the range: AV_{SS} - 0.5 V ≤ V_{in} ≤ AV_{DD} + 0.5 V, or DV_{SS} - 0.5 V ≤ V_{in} ≤ DV_{DD} + 0.5 V

Operating ranges define those limits between which the functionality of the device is guaranteed.

DC CHARACTERISTICS over COMMERCIAL operating ranges unless otherwise specified (refer to page 19 for driver types)

Parameter Symbol	Parameter Description	Test Conditions	Min	Max	Unit	
Digital Input Voltage						
V _{IL}	Input LOW Voltage			0.8	V	
V _{IH}	Input HIGH Voltage		2.0	DV _{DD} + 0.5	V	
Digital Output Voltage						
V _{OL}	Output LOW Voltage			0.5	V	
V _{OH}	Output HIGH Voltage	(Note 1)	2.4		V	
Digital Input Leakage Current						
I _{IX}	Input Leakage Current	V _{DD} = 5 V, V _{IN} = 0 V (Note 2)	-10	10	μA	
Digital Output Leakage Current						
I _{OZL}	Output Low Leakage Current (Note 3)	V _{OUT} = 0 V	-10		μA	
I _{OZH}	Output High Leakage Current (Note 3)	V _{OUT} = V _{DD}		10	μA	
Crystal Input Current						
V _{ILX}	XTAL1 Input LOW Threshold Voltage	V _{IN} = External Clock	-0.5	0.8	V	
V _{IHX}	XTAL1 Input HIGH Threshold Voltage	V _{IN} = External Clock	3.5	V _{DD} + 0.5	V	
I _{ILX}	XTAL1 Input LOW Current	V _{IN} = DV _{SS}	Active	-120	0	μA
			Sleep	-10	+10	μA
I _{IHX}	XTAL1 Input HIGH Current	V _{IN} = V _{DD}	Active	0	120	μA
			Sleep		400	μA
Attachment Unit Interface						
I _{IAXD}	Input Current at DI+ and DI-	AV _{SS} < V _{IN} < AV _{DD}	-500	+500	μA	
I _{IAXC}	Input current at CI+ and CI-	AV _{SS} < V _{IN} < AV _{DD}	-500	+500	μA	
V _{AOD}	Differential Output Voltage (DO+)-(DO-)	R _L = 78 Ω	630	1200	mV	
V _{AODOFF}	Transmit Differential Output Idle Voltage	R _L = 78 Ω (Note 5)	-40	+40	mV	

DC CHARACTERISTICS over COMMERCIAL operating ranges unless otherwise specified (continued)

Parameter Symbol	Parameter Description	Test Conditions	Min	Max	Unit
Attachment Unit Interface (Continued)					
IAODOFF	Transmit Differential Output Idle Current	$R_L = 78 \Omega$ (Note 4)	-1	+1	mA
VCMT	Transmit Output Common Mode Voltage	$R_L = 78 \Omega$	2.5	AV_{DD}	V
VODI	DO_{\pm} Transmit Differential Output Voltage Imbalance	$R_L = 78 \Omega$ (Note 5)		25	mV
VATH	Receive Data Differential Input Threshold	(Note 5)	-35	35	mV
VASQ	DI_{\pm} and CI_{\pm} Differential Input Threshold (Squelch)		-275	-160	mV
VIRDVD	DI_{\pm} and CI_{\pm} Differential Mode Input Voltage Range		-1.5	+1.5	V
VICM	DI_{\pm} and CI_{\pm} Input Bias Voltage	$I_{IN} = 0$ mA	$AV_{DD}-3.0$	$AV_{DD}-1.0$	V
VOPD	DO_{\pm} Undershoot Voltage at Zero Differential on Transmit Return to Zero (ETD)	(Note 5)		-100	mV
Twisted Pair Interface					
IIRXD	Input Current at RXD_{\pm}	$AV_{SS} < V_{IN} < AV_{DD}$	-500	500	μ A
RRXD	RXD_{\pm} Differential Input Resistance	(Note 5)	10		K Ω
VTIVB	$RXD+$, $RXD-$ Open Circuit Input Voltage (Bias)	$I_{IN} = 0$ mA	$AV_{DD} - 3.0$	$AV_{DD} - 1.5$	V
VTIDV	Differential Mode Input Voltage Range (RXD_{\pm})	$AV_{DD} = +5$ V	-3.1	+3.1	V
VTSQ+	RXD Positive Squelch Threshold (Peak)	Sinusoid $5 \text{ MHz} \leq f \leq 10 \text{ MHz}$	300	520	mV
VTSQ-	RXD Negative Squelch Threshold (Peak)	Sinusoid $5 \text{ MHz} \leq f \leq 10 \text{ MHz}$	-520	-300	mV
VTHS+	RXD Post-Squelch Positive Threshold (Peak)	Sinusoid $5 \text{ MHz} \leq f \leq 10 \text{ MHz}$	150	293	mV
VTHS-	RXD Post-Squelch Negative Threshold (Peak)	Sinusoid $5 \text{ MHz} \leq f \leq 10 \text{ MHz}$	-293	-150	mV
VLTSQ+	RXD Positive Squelch Threshold (Peak)	$LRT = 1$ (Note 6)	180	312	mV
VLTSQ-	RXD Negative Squelch Threshold (Peak)	$LRT = 1$ (Note 6)	-312	-180	mV
VLTHS+	RXD Post-Squelch Positive Threshold (Peak)	$LRT = 1$ (Note 6)	90	156	mV
VLTHS-	RXD Post-Squelch Negative Threshold (Peak)	$LRT = 1$ (Note 6)	-156	-90	mV

DC CHARACTERISTICS over COMMERCIAL operating ranges unless otherwise specified (continued)

Parameter Symbol	Parameter Description	Test Conditions	Min	Max	Unit
Twisted Pair Interface (continued)					
VRXDTH	RXD Switching Threshold	(Note 5)	-35	35	mV
VTXH	TXD \pm and TXP \pm Output HIGH Voltage	DV _{SS} = 0 V	DV _{DD} - 0.6	DV _{DD}	V
VTXL	TXD \pm and TXP \pm Output LOW Voltage	DV _{DD} = +5 V	DV _{SS}	DV _{SS} + 0.6	V
VTXI	TXD \pm and TXP \pm Differential Output Voltage Imbalance		-40	+40	mV
VTXOFF	TXD \pm and TXP \pm Idle Output Voltage	DV _{DD} = +5 V	-40	+40	mV
RTX	TXD \pm Differential Driver Output Impedance	(Note 5)		40	Ω
	TXP \pm Differential Driver Output Impedance	(Note 5)		80	Ω
IEEE 1149.1 (JTAG) Test Port					
V _{IL}	TCK, TMS, TDI			0.8	V
V _{IH}	TCK, TMS, TDI		2.0		V
V _{OL}	TDO	I _{OL} = 2.0 mA		0.4	V
V _{OH}	TDO	I _{OH} = -0.4 mA	2.4		V
I _{IL}	TCK, TMS, TDI	V _{DD} = 5.5 V, V _I = 0.5 V		-200	μ A
I _{IH}	TCK, TMS, TDI	V _{DD} = 5.5 V, V _I = 2.7 V		-100	μ A
I _{OZ}	TDO	0.4 V < V _{OUT} < V _{DD}	-10	+10	μ A
Power Supply Current					
I _{DD}	Active Power Supply Current	XTAL1 = 20 MHz		75	mA
I _{DDCOMA}	Coma Mode Power Supply Current	$\overline{\text{SLEEP}}$ active		200	μ A
I _{DDSNOOZE}	Snooze Mode Power Supply Current	Awake bit set active		10	mA

Notes:

1. V_{OH} does not apply to open-drain output pins.
2. I_{Ix} applies to all input only pins except D \pm , C \pm , and XTAL1.
3. I_{OZL} applies to all three-state output pins and bi-directional pins, except PRDB[7:0]. I_{OZH} applies to pins PRDB[7:0].
4. Correlated to other tested parameters—not tested directly.
5. Parameter not tested.
6. LRT is bit 9 of Mode register (CSR15)

SWITCHING CHARACTERISTICS: BUS MASTER MODE

Parameter Symbol	Parameter Description	Test Conditions	Min	Max	Unit
Input/Output Write Timing					
t _{IOW1}	AEN, $\overline{\text{SBHE}}$, SA0–9 Setup to $\downarrow \overline{\text{IOW}}$		10		ns
t _{IOW2}	AEN, $\overline{\text{SBHE}}$, SA0–9 Hold After $\uparrow \overline{\text{IOW}}$		5		ns
t _{IOW3}	$\overline{\text{IOW}}$ Assertion		100		ns
t _{IOW4}	$\overline{\text{IOW}}$ Inactive		55		ns
t _{IOW5}	SD Setup to $\uparrow \overline{\text{IOW}}$		10		ns
t _{IOW6}	SD Hold After $\uparrow \overline{\text{IOW}}$		10		ns
t _{IOW7}	$\downarrow \text{IOCHRDY}$ Delay From $\downarrow \overline{\text{IOW}}$		0	35	ns
t _{IOW8}	IOCHRDY Inactive		125		ns
t _{IOW9}	$\uparrow \text{IOCHRDY}$ to $\uparrow \overline{\text{IOW}}$		0		ns
Input/Output Read Timing					
t _{IOR1}	AEN, $\overline{\text{SBHE}}$, SA0–9 Setup to $\downarrow \overline{\text{IOR}}$		15		ns
t _{IOR2}	AEN, $\overline{\text{SBHE}}$, SA0–9 Hold After $\uparrow \overline{\text{IOR}}$		5		ns
t _{IOR3}	$\overline{\text{IOR}}$ Inactive		55		ns
t _{IOR4}	SD Hold After $\uparrow \overline{\text{IOR}}$		0	20	ns
t _{IOR5}	SD Valid From $\downarrow \overline{\text{IOR}}$		0	110	ns
t _{IOR6}	$\downarrow \text{IOCHRDY}$ Delay From $\downarrow \overline{\text{IOR}}$		0	35	ns
t _{IOR7}	IOCHRDY Inactive		125		ns
t _{IOR8}	SD Valid From $\uparrow \text{IOCHRDY}$		–130	10	ns
I/O To Memory Command Inactive					
t _{IOM1}	$\uparrow \overline{\text{IOW/MEMW}}$ to $\downarrow (\overline{\text{S}})\overline{\text{MEMR/IOR}}$		55		ns
t _{IOM2}	$\uparrow (\overline{\text{S}})\overline{\text{MEMR/IOR}}$ to $\downarrow \overline{\text{IOW/MEMW}}$		55		ns
IOCS16 Timing					
t _{IOCS1}	AEN, $\overline{\text{SBHE}}$, SA0–9 to $\downarrow \overline{\text{IOCS16}}$		0	35	ns
t _{IOCS2}	AEN, $\overline{\text{SBHE}}$, SA0–9 to $\overline{\text{IOCS16}}$ Tristated		0	25	ns
Master Mode Bus Acquisition					
t _{MMA1}	$\overline{\text{REF}}$ Inactive to $\downarrow \overline{\text{DACK}}$		5		ns
t _{MMA2}	$\uparrow \text{DRQ}$ to $\downarrow \overline{\text{DACK}}$		0		ns
t _{MMA3}	$\overline{\text{DACK}}$ Inactive		55		ns
t _{MMA4}	$\downarrow \overline{\text{DACK}}$ to $\downarrow \overline{\text{MASTER}}$			35	ns
t _{MMA5}	$\downarrow \overline{\text{MASTER}}$ to Active Command, $\overline{\text{SBHE}}$, SA0–19, LA17–23		125	185	ns

SWITCHING CHARACTERISTICS: BUS MASTER MODE (continued)

Parameter Symbol	Parameter Description	Test Conditions	Min	Max	Unit
Master Mode Bus Release					
tMMBR1	Command Deassert to ↓ DRQ		45	65	ns
tMMBR2	↓ DRQ to ↑ $\overline{\text{DACK}}$		0		ns
tMMBR3	↓ DRQ to ↑ $\overline{\text{MASTER}}$		40	60	ns
tMMBR4	↓ DRQ to Command, $\overline{\text{SBHE}}$, SA0–19, LA17–23 Tristated,		–15	0	ns
Master Write Cycles					
tMMW1	$\overline{\text{SBHE}}$, SA0–19, LA17–23, Active to ↓ $\overline{\text{MEMW}}$	(Note 1)	EXTIME + 45	EXTIME + 65	ns
tMMW2	$\overline{\text{MEMW}}$ Active	(Note 2)	MSWRA – 10	MSWRA + 5	ns
tMMW3	$\overline{\text{MEMW}}$ Inactive	(Note 1)	EXTIME + 97	EXTIME + 105	ns
tMMW4	↑ $\overline{\text{MEMW}}$ to $\overline{\text{SBHE}}$, SA0–19, LA17–23, SD Inactive		45	55	ns
tMMW5	$\overline{\text{SBHE}}$, SA0–19, LA17–23, SD Hold After ↑ $\overline{\text{MEMW}}$		45	60	ns
tMMW6	$\overline{\text{SBHE}}$, SA0–19, LA17–23, SD Setup to ↓ $\overline{\text{MEMW}}$	(Note 1)	EXTIME + 45	EXTIME + 55	ns
tMMW7	↓ IOCHRDY Delay From ↓ $\overline{\text{MEMW}}$		tMMW2 – 175		ns
tMMW8	IOCHRDY Inactive		55		ns
tMMW9	↑ IOCHRDY to ↑ $\overline{\text{MEMW}}$		130		ns
tMMW10	SD Active to ↓ $\overline{\text{MEMW}}$	(Note 1)	EXTIME + 20	EXTIME + 60	ns
tMMW11	SD Setup to ↓ $\overline{\text{MEMW}}$	(Note 1)	EXTIME + 20	EXTIME + 60	ns
Master Read Cycles					
tMMR1	$\overline{\text{SBHE}}$, SA0–19, LA17–23, Active to ↓ $\overline{\text{MEMR}}$	(Note 1)	EXTIME + 45	EXTIME + 60	ns
tMMR2	$\overline{\text{MEMR}}$ Active	(Note 2)	MSRDA – 10	MSRDA + 5	ns
tMMR3	$\overline{\text{MEMR}}$ Inactive	(Note 1)	EXTIME + 97	EXTIME + 105	ns
tMMR4	↑ $\overline{\text{MEMR}}$ to $\overline{\text{SBHE}}$, SA0–19, LA17–23 Inactive		45	55	ns
tMMR5	$\overline{\text{SBHE}}$, SA0–19, LA17–23 Hold After ↑ $\overline{\text{MEMW}}$		45	55	ns
tMMR6	$\overline{\text{SBHE}}$, SA0–19, LA17–23 Setup to ↓ $\overline{\text{MEMR}}$	(Note 1)	EXTIME + 45	EXTIME + 55	ns
tMMR7	↓ IOCHRDY Delay From ↓ $\overline{\text{MEMR}}$		tMMR2 – 175		ns
tMMR8	IOCHRDY Inactive		55		ns
tMMR9	↑ IOCHRDY to ↑ $\overline{\text{MEMR}}$		130		ns
tMMR10	SD Setup to ↑ $\overline{\text{MEMR}}$		30		ns
tMMR11	SD Hold After ↑ $\overline{\text{MEMR}}$		0		ns

SWITCHING CHARACTERISTICS: BUS MASTER MODE (continued)

Parameter Symbol	Parameter Description	Test Conditions	Min	Max	Unit
Master Mode Address PROM Read					
tMA1	$\downarrow \overline{IO\overline{R}}$ to $\downarrow \overline{A\overline{P\overline{C\overline{S}}}}$		125	260	ns
tMA2	$\overline{A\overline{P\overline{C\overline{S}}}}$ Active		140	155	ns
tMA3	PRDB Setup to $\uparrow \overline{A\overline{P\overline{C\overline{S}}}}$		20		ns
tMA4	PRDB Hold After $\uparrow \overline{A\overline{P\overline{C\overline{S}}}}$		0		ns
tMA5	$\uparrow \overline{A\overline{P\overline{C\overline{S}}}}$ to $\uparrow \overline{IO\overline{C\overline{H\overline{R\overline{D\overline{Y}}}}}$		45	65	ns
tMA6	SD Valid From $\uparrow \overline{IO\overline{C\overline{H\overline{R\overline{D\overline{Y}}}}}$		0	10	ns
Master Mode Boot PROM Read					
tMB1	$\overline{R\overline{E\overline{F}}}$, $\overline{S\overline{B\overline{H\overline{E}}}}$, SA0–19 Setup to $\downarrow \overline{S\overline{M\overline{E\overline{M\overline{R}}}}}$		10		ns
tMB2	$\overline{R\overline{E\overline{F}}}$, $\overline{S\overline{B\overline{H\overline{E}}}}$, SA0–19 Hold $\uparrow \overline{S\overline{M\overline{E\overline{M\overline{R}}}}}$		5		ns
tMB3	$\downarrow \overline{IO\overline{C\overline{H\overline{R\overline{D\overline{Y}}}}}$ Delay From $\downarrow \overline{S\overline{M\overline{E\overline{M\overline{R}}}}}$		0	35	ns
tMB4	$\overline{S\overline{M\overline{E\overline{M\overline{R}}}}$ Inactive		55		ns
tMB5	$\downarrow \overline{S\overline{M\overline{E\overline{M\overline{R}}}}$ to $\downarrow \overline{B\overline{P\overline{C\overline{S}}}}$		125	260	ns
tMB6	$\overline{B\overline{P\overline{C\overline{S}}}}$ Active		140	155	ns
tMB7	$\uparrow \overline{B\overline{P\overline{C\overline{S}}}}$ to $\uparrow \overline{IO\overline{C\overline{H\overline{R\overline{D\overline{Y}}}}}$		45	65	ns
tMB8	PRDB Setup to $\uparrow \overline{B\overline{P\overline{C\overline{S}}}}$		20		ns
tMB9	PRDB Hold After $\uparrow \overline{B\overline{P\overline{C\overline{S}}}}$		0		ns
tMB10	SD Valid From $\uparrow \overline{IO\overline{C\overline{H\overline{R\overline{D\overline{Y}}}}}$		0	10	ns
tMB11	SD Hold After $\uparrow \overline{S\overline{M\overline{E\overline{M\overline{R}}}}$		0	20	ns

Notes:

1. *EXTIME* is 100 ns when *ISACSR2*, bit 4, is cleared (default). *EXTIME* is 0 ns when *ISACSR2*, bit 4, is set.
2. *MSRDA* and *MSWDA* are parameters which are defined in registers *ISACSR0* and *ISACSR1*, respectively.

SWITCHING CHARACTERISTICS: SHARED MEMORY MODE

Parameter Symbol	Parameter Description	Test Conditions	Min	Max	Unit
Input/Output Write Timing					
t _{IOW1}	AEN, $\overline{\text{SBHE}}$, SA0–9 Setup to $\downarrow \overline{\text{IOW}}$		10		ns
t _{IOW2}	AEN, $\overline{\text{SBHE}}$, SA0–9 Hold After $\uparrow \overline{\text{IOW}}$		5		ns
t _{IOW3}	$\overline{\text{IOW}}$ Assertion		150		ns
t _{IOW4}	$\overline{\text{IOW}}$ Inactive		55		ns
t _{IOW5}	SD Setup to $\uparrow \overline{\text{IOW}}$		10		ns
t _{IOW6}	SD Hold After $\uparrow \overline{\text{IOW}}$		10		ns
t _{IOW7}	$\downarrow \text{IOCHRDY}$ Delay From $\downarrow \overline{\text{IOW}}$		0	35	ns
t _{IOW8}	IOCHRDY Inactive		125		ns
t _{IOW9}	$\uparrow \text{IOCHRDY}$ to $\uparrow \overline{\text{IOW}}$		0		ns
Input/Output Read Timing					
t _{IOR1}	AEN, $\overline{\text{SBHE}}$, SA0–9 Setup to $\downarrow \overline{\text{IOR}}$		15		ns
t _{IOR2}	AEN, $\overline{\text{SBHE}}$, SA0–9 Hold After $\uparrow \overline{\text{IOR}}$		5		ns
t _{IOR3}	$\overline{\text{IOR}}$ Inactive		55		ns
t _{IOR4}	SD Hold After $\uparrow \overline{\text{IOR}}$		0	20	ns
t _{IOR5}	SD Valid From $\downarrow \overline{\text{IOR}}$		0	110	ns
t _{IOR6}	$\downarrow \text{IOCHRDY}$ Delay From $\downarrow \overline{\text{IOR}}$		0	35	ns
t _{IOR7}	IOCHRDY Inactive		125		ns
t _{IOR8}	SD Valid From $\uparrow \text{IOCHRDY}$		–130	10	ns
Memory Write Timing					
t _{MW1}	SA0–9, PRAB10–15, $\overline{\text{SBHE}}$, $\downarrow \text{SMAM}$ Setup to $\downarrow \overline{\text{MEMW}}$		10		ns
t _{MW2}	SA0–9, PRAB10–15, $\overline{\text{SBHE}}$, $\uparrow \text{SMAM}$ Hold After $\uparrow \overline{\text{MEMW}}$		5		ns
t _{MW3}	$\overline{\text{MEMW}}$ Assertion		150		ns
t _{MW4}	$\overline{\text{MEMW}}$ Inactive		55		ns
t _{MW5}	SD Setup to $\uparrow \overline{\text{MEMW}}$		10		ns
t _{MW6}	SD Hold After $\uparrow \overline{\text{MEMW}}$		10		ns
t _{MW7}	$\downarrow \text{IOCHRDY}$ Delay From $\downarrow \overline{\text{MEMW}}$		0	35	ns
t _{MW8}	IOCHRDY Inactive		125		ns
t _{MW9}	$\uparrow \overline{\text{MEMW}}$ to $\uparrow \text{IOCHRDY}$		0		ns

SWITCHING CHARACTERISTICS: SHARED MEMORY MODE (continued)

Parameter Symbol	Parameter Description	Test Conditions	Min	Max	Unit
Memory Read Timing					
tMR1	SA0–9, PRAB10–15, $\overline{\text{SBHE}}$, $\downarrow \overline{\text{SMAM/BPAM}}$ Setup to $\downarrow \overline{\text{MEMR}}$		10		ns
tMR2	SA0–9, PRAB10–15, $\overline{\text{SBHE}}$, $\uparrow \overline{\text{SMAM/BPAM}}$ Hold After $\uparrow \overline{\text{MEMR}}$		5		ns
tMR3	$\overline{\text{MEMR}}$ Inactive		55		ns
tMR4	SD Hold After $\uparrow \overline{\text{MEMR}}$		0	20	ns
tMR5	SD Valid From $\downarrow \overline{\text{MEMR}}$		0	110	ns
tMR6	$\downarrow \text{IOCHRDY}$ Delay From $\downarrow \overline{\text{MEMR}}$		0	35	ns
tMR7	IOCHRDY Inactive		125		ns
tMR8	SD Valid From $\uparrow \text{IOCHRDY}$		–130	10	ns
I/O To Memory Command Inactive					
tIOM1	$\downarrow \overline{\text{IOW/MEMW}}$ to $\downarrow (\overline{\text{S}})\overline{\text{MEMR/IOR}}$		55		ns
tIOM2	$\downarrow (\overline{\text{S}})\overline{\text{MEMR/IOR}}$ to $\downarrow \overline{\text{IOW/MEMW}}$		55		ns
IOCS16 Timing					
tIOCS1	AEN, $\overline{\text{SBHE}}$, SA0–9 to $\downarrow \overline{\text{IOCS16}}$		0	35	ns
tIOCS2	AEN, $\overline{\text{SBHE}}$, SA0–9 to $\overline{\text{IOCS16}}$ tristated		0	25	ns
SRAM Read/Write, Boot PROM Read, Address PROM Read on Private Bus					
tPR1	$\uparrow \overline{\text{ABOE}}$ to PRAB10–15 Tristated		0	20	ns
tPR2	$\uparrow \overline{\text{ABOE}}$ to PRAB10–15 Active (Driven by Am79C960)		25	55	ns
tPR3	PRAB10–15 Inactive to $\downarrow \overline{\text{ABOE}}$		5	25	ns
tPR4	PRAB Change to PRAB Change, SRAM Access		95	105	ns
tPR5	PRDB Setup to PRAB Change, SRAM Access		20		ns
tPR6	PRDB Hold After PRAB Change, SRAM Access		0		ns
tPR7	PRAB Change to PRAB Change, APROM Access		145	155	ns

SWITCHING CHARACTERISTICS: SHARED MEMORY MODE (continued)

Parameter Symbol	Parameter Description	Test Conditions	Min	Max	Unit
SRAM Read/Write, Boot PROM Read, Address PROM Read on Private Bus (continued)					
t _{PR8}	PRDB Setup to PRAB Change, APROM Access		20		ns
t _{PR9}	PRDB Hold After PRAB Change, APROM Access		0		ns
t _{PR10}	PRAB Change to PRAB Change, BPROM Access		145	155	ns
t _{PR11}	PRDB Setup to PRAB Change, BPROM Access		20		ns
t _{PR12}	PRDB Hold After PRAB Change, BPROM Access		0		ns
t _{PR13}	PRAB Change to PRAB Change, SRAM Write		145	155	ns
t _{PR14}	PRAB Change to $\downarrow \overline{SRWE}$		20	30	ns
t _{PR15}	PRAB Change to $\uparrow \overline{SRWE}$		120	130	ns

SWITCHING CHARACTERISTICS: EADI

Parameter Symbol	Parameter Description	Test Conditions	Min	Max	Unit
tEAD1	SRD Setup to \uparrow SRDCLK		40		ns
tEAD2	SRD Hold to \uparrow SRDCLK		40		ns
tEAD3	$\overline{\text{SF}}/\overline{\text{BD}}$ Change to \downarrow SRDCLK		-15	+15	ns
tEAD4	$\overline{\text{EAR}}$ Deassertion to \uparrow SRDCLK (First Rising Edge)		50		ns
tEAD5	$\overline{\text{EAR}}$ Assertion After SFD Event (Packet Rejection)		0	51,090	ns
tEAD6	$\overline{\text{EAR}}$ Assertion		110		ns

Note:

External Address Detection Interface is invoked by setting bit 3 in ISACSR2 and resetting bit 0 in ISACSR2. External MAU select is not available when EADISEL bit is set.

SWITCHING CHARACTERISTICS: JTAG (IEEE 1149.1) INTERFACE

Parameter Symbol	Parameter Description	Test Conditions	Min	Max	Unit
tJTG1	TCK HIGH Assertion		20		ns
tJTG2	TCK Period		50		ns
tJTG3	TDI Setup Before \uparrow TCK		5		ns
tJTG4	TDI, TMS Hold After \uparrow TCK		5		ns
tJTG5	TMS Setup Before \uparrow TCK		8		ns
tJTG6	TDO Active After \downarrow TCK		0	30	ns
tJTG7	TDO Change After \downarrow TCK		0	30	ns
tJTG8	TDO Tristate After \downarrow TCK		0	25	ns

Note:

JTAG logic is reset with an internal Power-On Reset circuit independent of Sleep Modes.

SWITCHING CHARACTERISTICS: GPSI

Parameter Symbol	Parameter Description	Test Conditions	Min	Max	Unit
Transmit Timing					
tGPT1	TCLK Period (802.3 Compliant)		99.99	100.01	ns
tGPT2	TCLK HIGH Time		40	60	ns
tGPT3	TX and TENA Delay from \uparrow TCLK		0	70	ns
tGPT4	RENA Setup Before \uparrow TCLK (Last Bit)		210		ns
tGPT5	RENA Hold After \downarrow TENA		0		ns
tGPT6	CLSN Active Time to Trigger Collision	(Note 1)	110		ns
tGPT7	CLSN Active to \downarrow RENA to Prevent LCAR Assertion		0		ns
tGPT8	CLSN Active to \downarrow RENA for SQE Hearbeat Window		0	4.0	μ s
T _{gpt9}	CLSN Active to \uparrow RENA for Normal Collision		0	51.2	μ s
Receive Timing					
tGPR1	RCLK Period	(Note 2)	80	120	ns
tGPR2	RCLK HIGH Time	(Note 2)	30	80	ns
tGPR3	RCLK LOW Time	(Note 2)	30	80	ns
tGPR4	RX and RENA Setup to \uparrow RCLK		15		ns
tGPR5	RX Hold After \uparrow RCLK		15		ns
tGPR6	RENA Hold After \downarrow RCLK		0		ns
tGPR7	CLSN Active to First \uparrow RCLK (Collision Recognition)		0		ns
tGPR8	CLSN Active to \uparrow RCLK for Address Type Designation Bit	(Note 3)	51.2		μ s
tGPR9	CLSN Setup to Last \uparrow RCLK for Collision Recognition		210		ns
tGPR10	CLSN Active		110		ns
tGPR11	CLSN Inactive Setup to First \uparrow RCLK		300		ns
tGPR12	CLSN Inactive Hold to Last \uparrow RCLK		300		ns

Notes:

1. CLSN must be asserted for a continuous period of 110 ns or more. Assertion for less than 110 ns period may or may not result in CLSN recognition.
2. RCLK should meet jitter requirements of IEEE 802.3 specification.
3. CLSN assertion before 51.2 μ s will be indicated as a normal collision. CLSN assertion after 51.2 μ s will be considered as a Late Receive Collision.

SWITCHING CHARACTERISTICS: AUI

Parameter Symbol	Parameter Description	Test Conditions	Min	Max	Unit
AUI Port					
t _{DOTR}	DO+,DO- Rise Time (10% to 90%)		2.5	5.0	ns
t _{DOTF}	DO+,DO- Fall Time (90% to 10%)		2.5	5.0	ns
t _{DORM}	DO+,DO- Rise and Fall Time Mismatch			1.0	ns
t _{DOETD}	DO+/- End of Transmission		200	375	ns
t _{PWODI}	DI Pulse Width Accept/Reject Threshold	V _{IN} > V _{ASQ} (Note 1)	15	45	ns
t _{PWKDI}	DI Pulse Width Maintain/Turn-Off Threshold	V _{IN} > V _{ASQ} (Note 2)	136	200	ns
t _{PWOCI}	CI Pulse Width Accept/Reject Threshold	V _{IN} > V _{ASQ} (Note 3)	10	26	ns
t _{PWKCI}	CI Pulse Width Maintain/Turn-Off Threshold	V _{IN} > V _{ASQ} (Note 4)	90	160	ns
Internal MENDEC Clock Timing					
t _{X1}	XTAL1 Period	V _{IN} = External Clock	49.995	50.005	ns
t _{X1H}	XTAL1 HIGH Pulse Width	V _{IN} = External Clock	20		ns
t _{X1L}	XTAL1 LOW Pulse Width	V _{IN} = External Clock	20		ns
t _{X1R}	XTAL1 Rise Time	V _{IN} = External Clock		5	ns
t _{X1F}	XTAL1 Fall Time	V _{IN} = External Clock		5	ns

Notes:

1. DI pulses narrower than t_{PWODI} (min) will be rejected; pulses wider than t_{PWODI} (max) will turn internal DI carrier sense on.
2. DI pulses narrower than t_{PWKDI} (min) will maintain internal DI carrier sense on; pulses wider than t_{PWKDI} (max) will turn internal DI carrier sense off.
3. CI pulses narrower than t_{PWOCI} (min) will be rejected; pulses wider than t_{PWOCI} (max) will turn internal CI carrier sense on.
4. CI pulses narrower than t_{PWKCI} (min) will maintain internal CI carrier sense on; pulses wider than t_{PWKCI} (max) will turn internal CI carrier sense off.

SWITCHING CHARACTERISTICS: 10BASE-T INTERFACE

Parameter Symbol	Parameter Description	Test Conditions	Min	Max	Unit
Transmit Timing					
tTETD	Transmit Start of Idle		250	350	ns
tTR	Transmitter Rise Time	(10% to 90%)		5.5	ns
tTF	Transmitter Fall Time	(90% to 10%)		5.5	ns
tTM	Transmitter Rise and Fall Time Mismatch			1	ns
tPERLP	Idle Signal Period		8	24	ms
tpWLP	Idle Link Pulse Width	(Note 1)	75	120	ns
tpWPLP	Predistortion Idle Link Pulse Width	(Note 1)	45	55	ns
tJA	Transmit Jabber Activation Time		20	150	ms
tJR	Transmit Jabber Reset Time		250	750	ms
Receive Timing					
tpWNRD	RXD Pulse Width Not to Turn Off Internal Carrier Sense	VIN > VTHS (min)	136	–	ns
tpWROFF	RXD Pulse Width to Turn Off	VIN > VTHS (min)		200	ns

Note:

1. Not tested; parameter guaranteed by characterization.

KEY TO SWITCHING WAVEFORMS

WAVEFORM	INPUTS	OUTPUTS
	Must Be Steady	Will Be Steady
	May Change from H to L	Will Be Changing from H to L
	May Change from L to H	Will Be Changing from L to H
	Don't Care Any Change Permitted	Changing State Unknown
	Does Not Apply	Center Line is High Impedance "Off" State

KS000010

SWITCHING TEST CIRCUITS

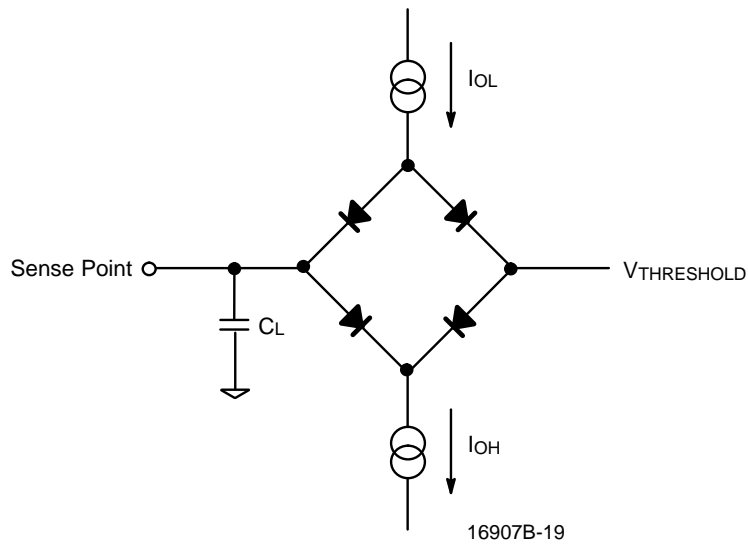

16907B-19

Normal and Three-State Outputs

SWITCHING TEST CIRCUITS

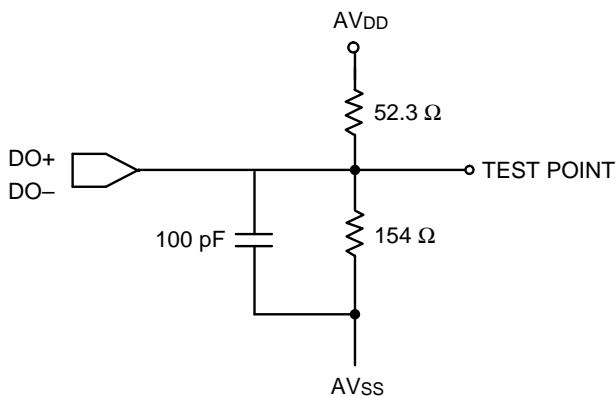

16907B-20

AUI DO Switching Test Circuit

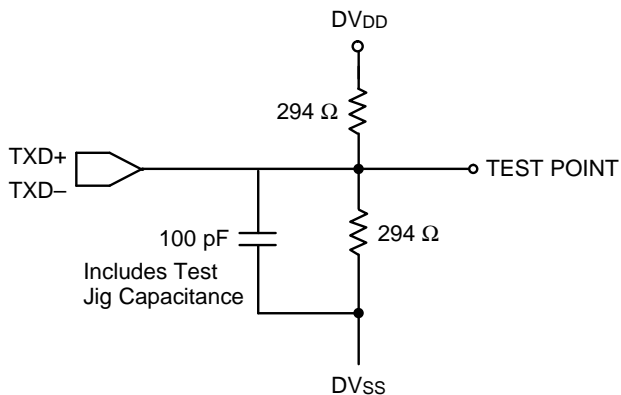

16907B-21

TXD Switching Test Circuit

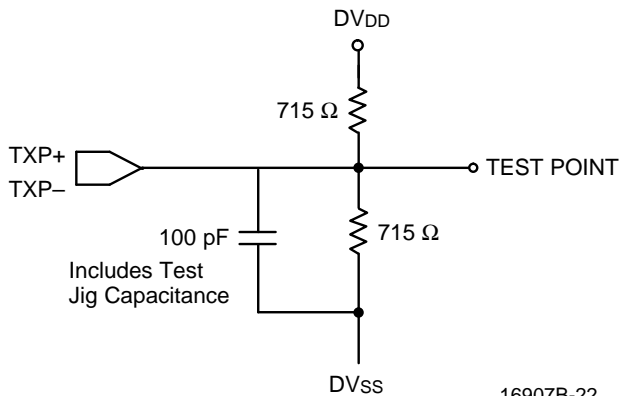

16907B-22

TXP Outputs Test Circuit

SWITCHING WAVEFORMS: BUS MASTER MODE

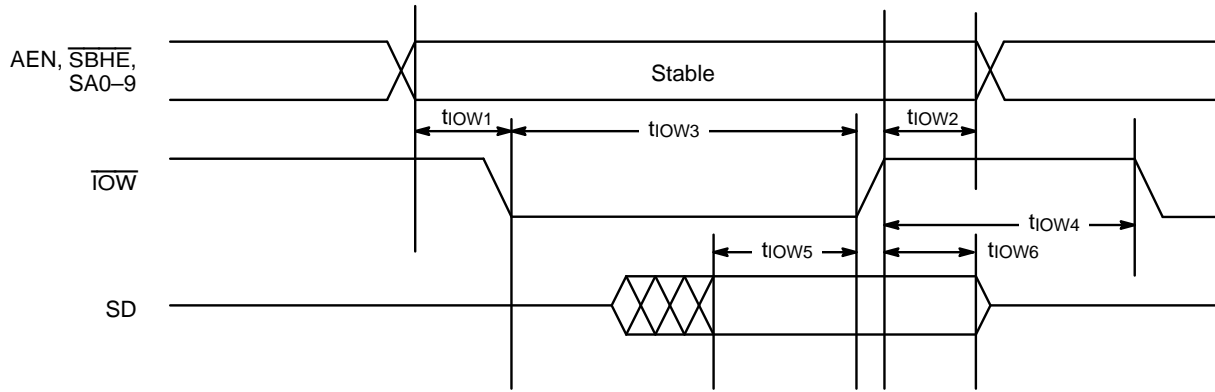

16907B-23

I/O Write without Wait States

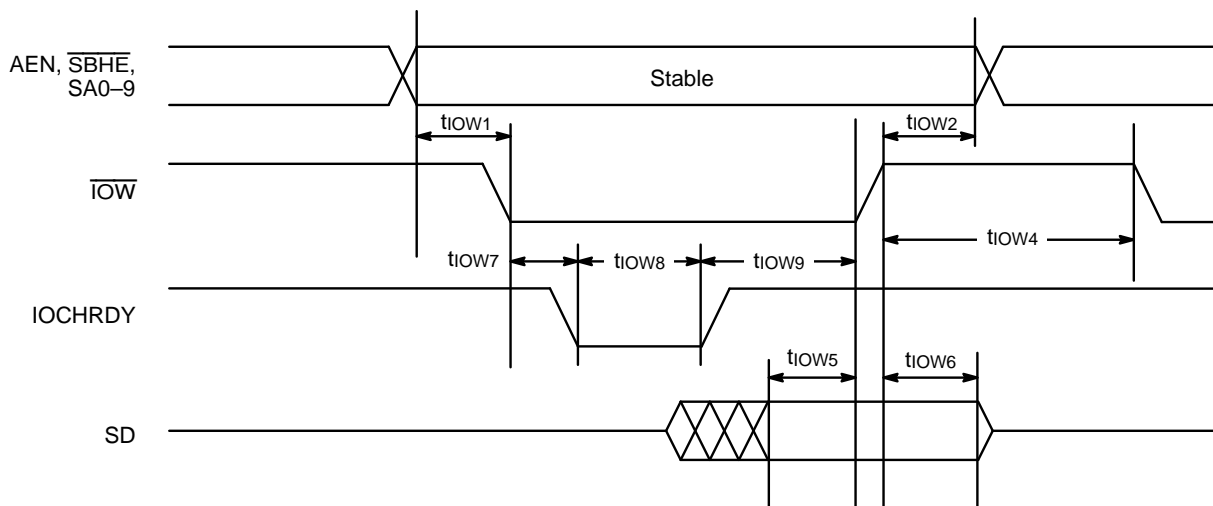

16907B-24

I/O Write with Wait States

SWITCHING WAVEFORMS: BUS MASTER MODE

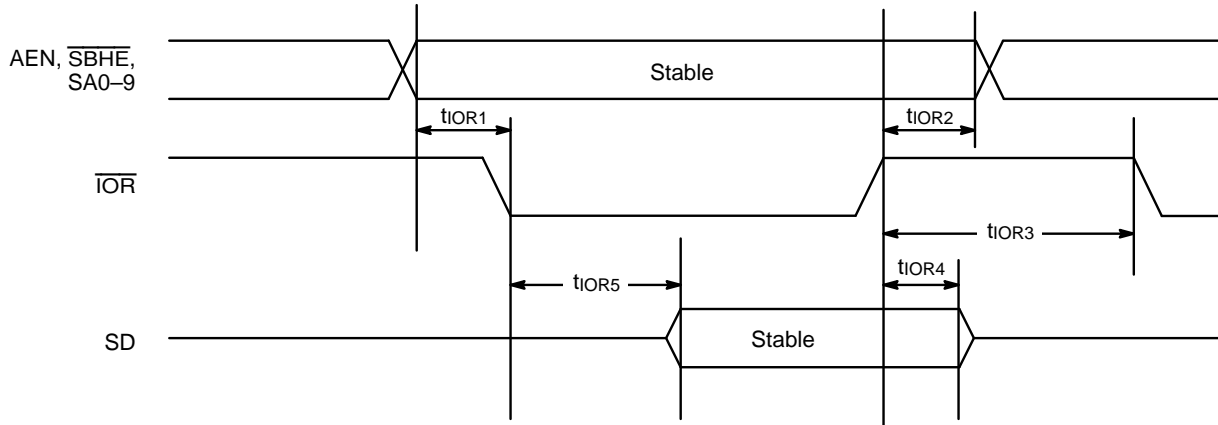

16907B-25

I/O Read without Wait States

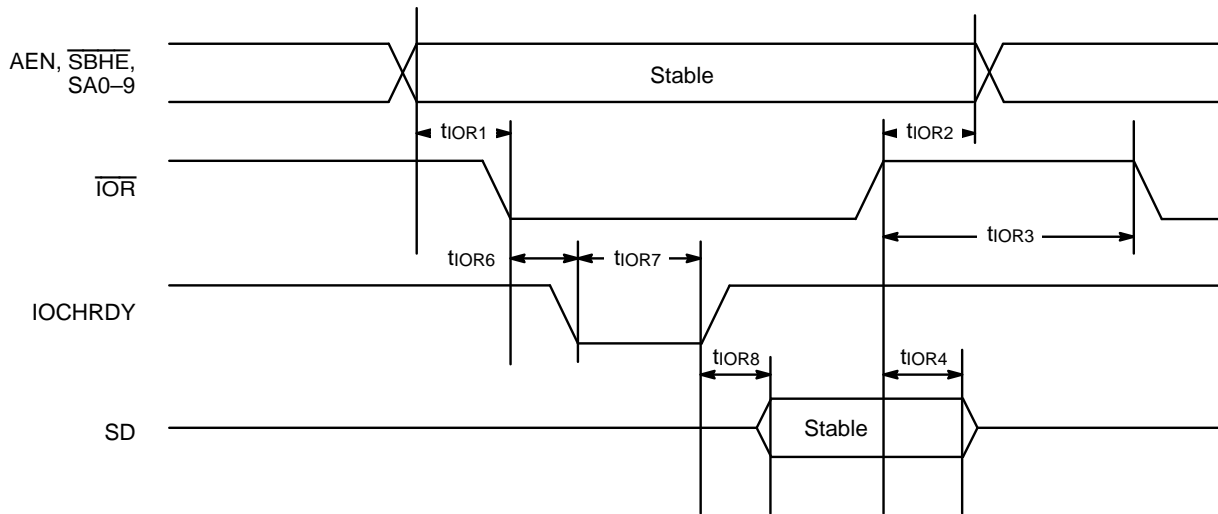

16907B-26

I/O Read with Wait States

SWITCHING WAVEFORMS: BUS MASTER MODE

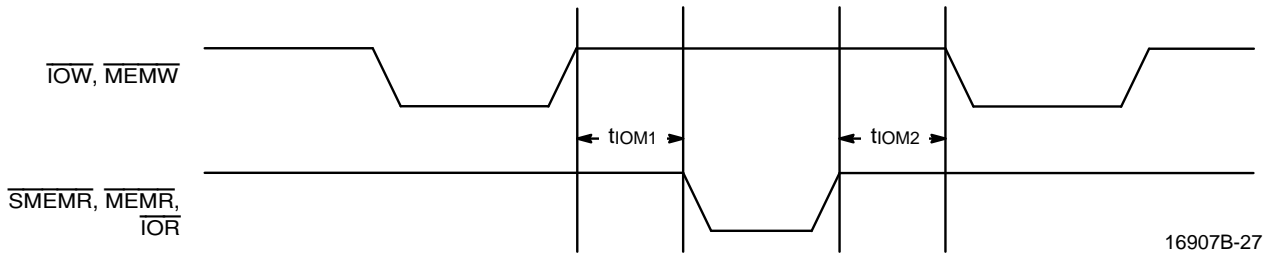

I/O to Memory Command Inactive Time

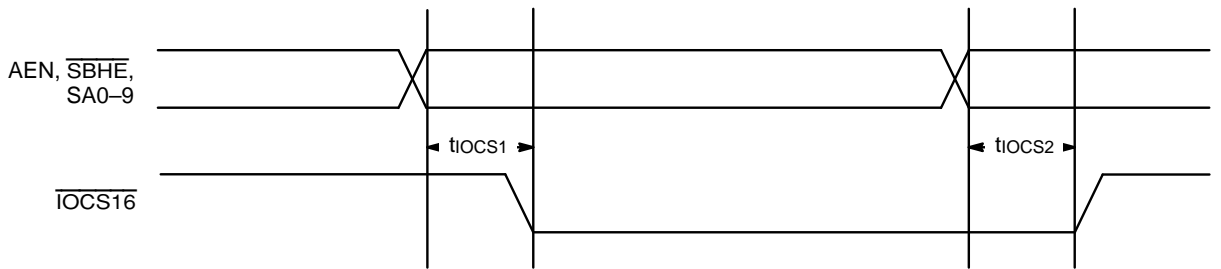

IOCS16 Timings

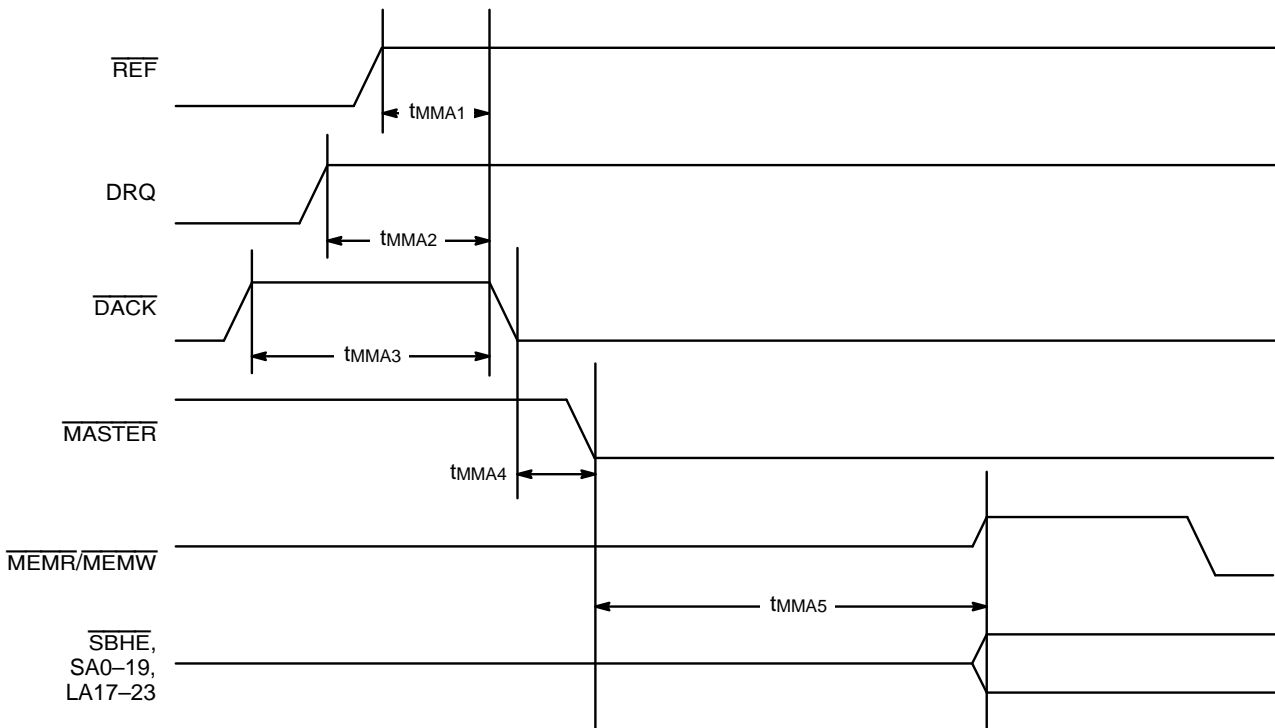

Bus Acquisition

SWITCHING WAVEFORMS: BUS MASTER MODE

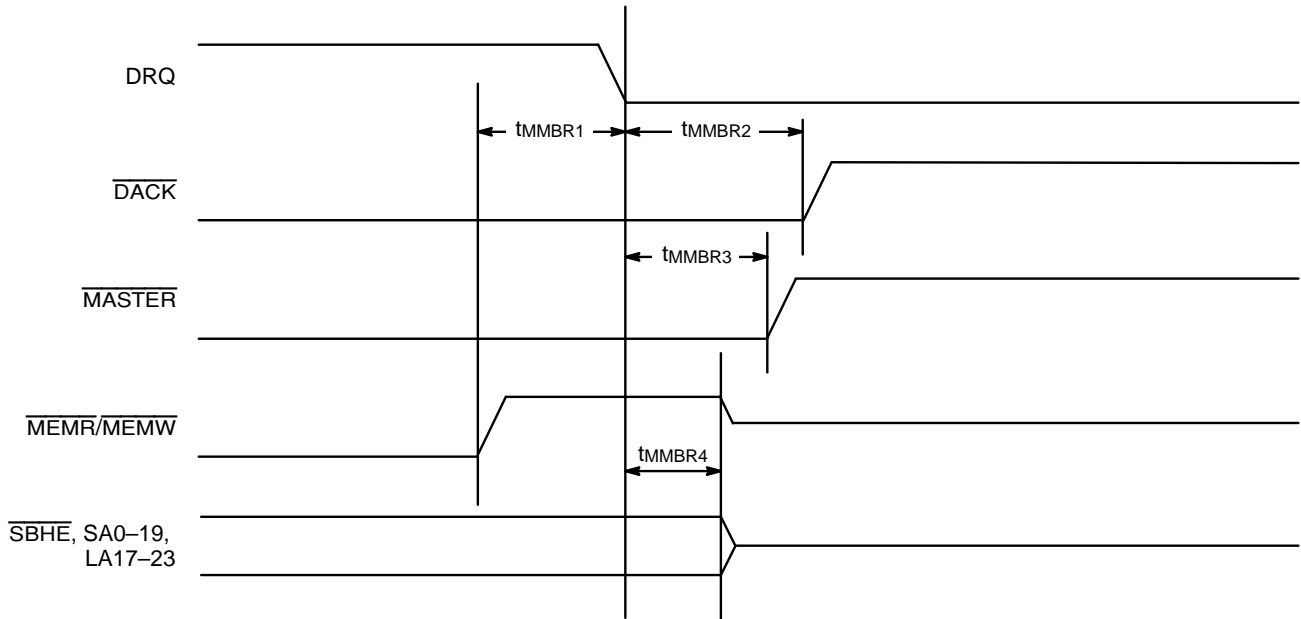

16907B-30

Bus Release

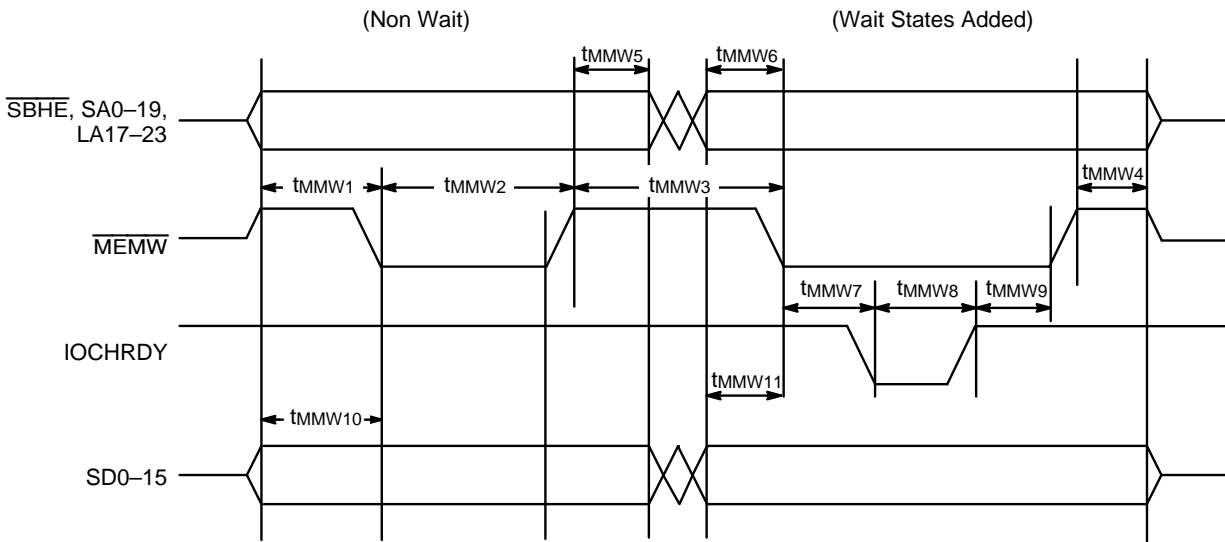

16907B-31

Write Cycles

SWITCHING WAVEFORMS: BUS MASTER MODE

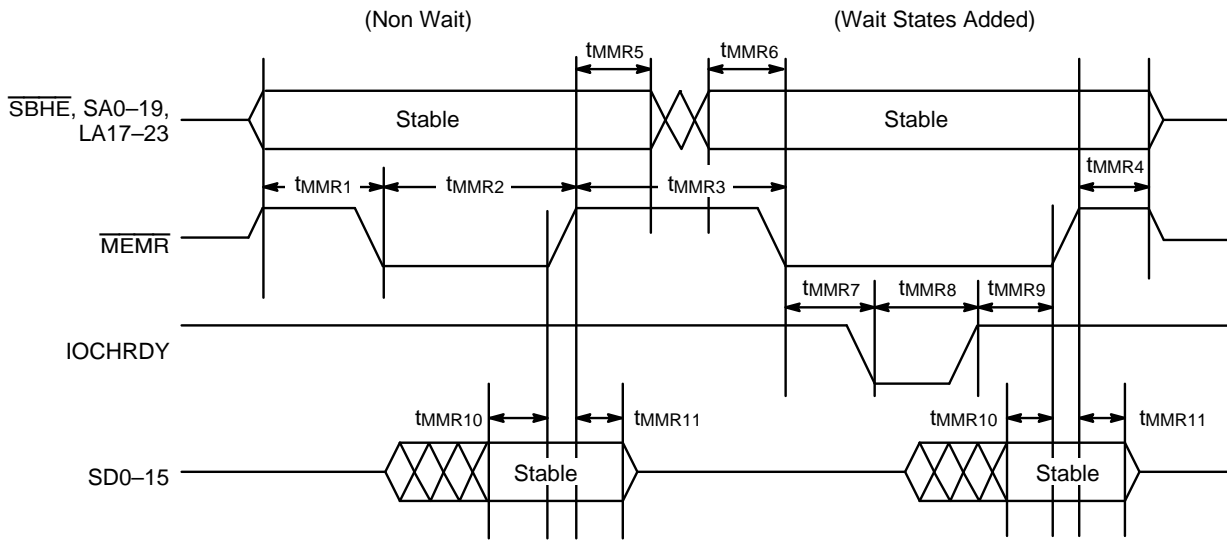

16907B-32

Read Cycles

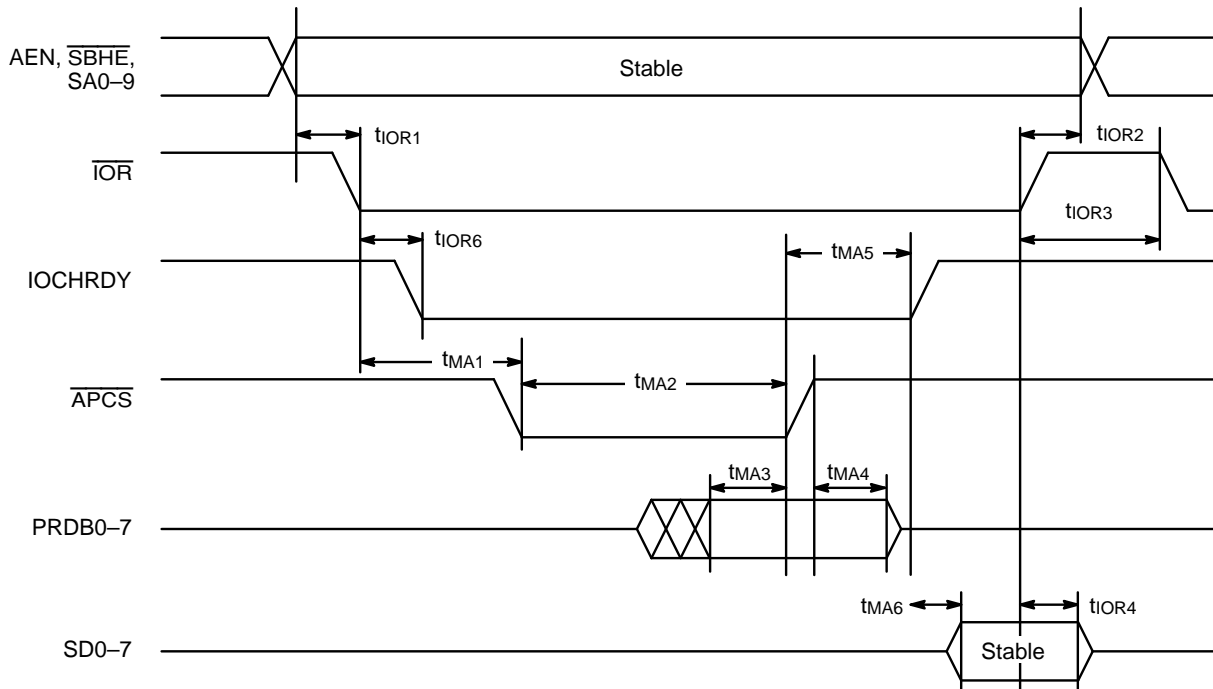

16907B-33

Address PROM Read Cycle

SWITCHING WAVEFORMS: BUS MASTER MODE

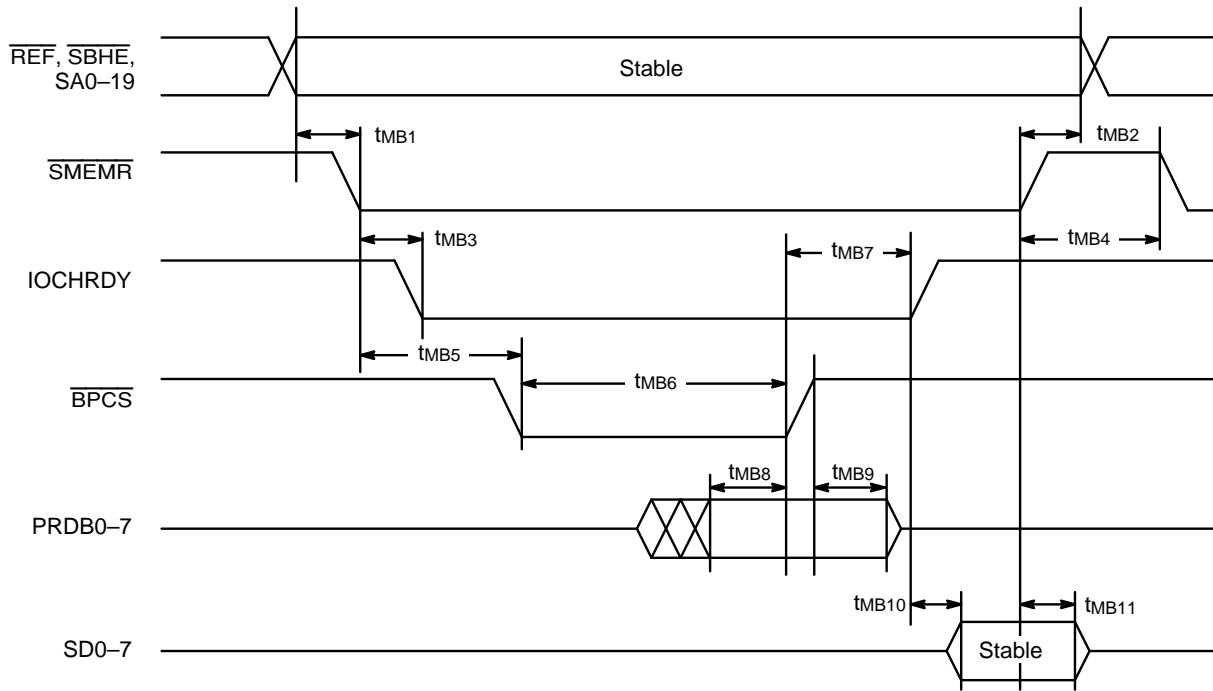

16907B-34

Boot PROM Read Cycle

SWITCHING WAVEFORMS: SHARED MEMORY MODE

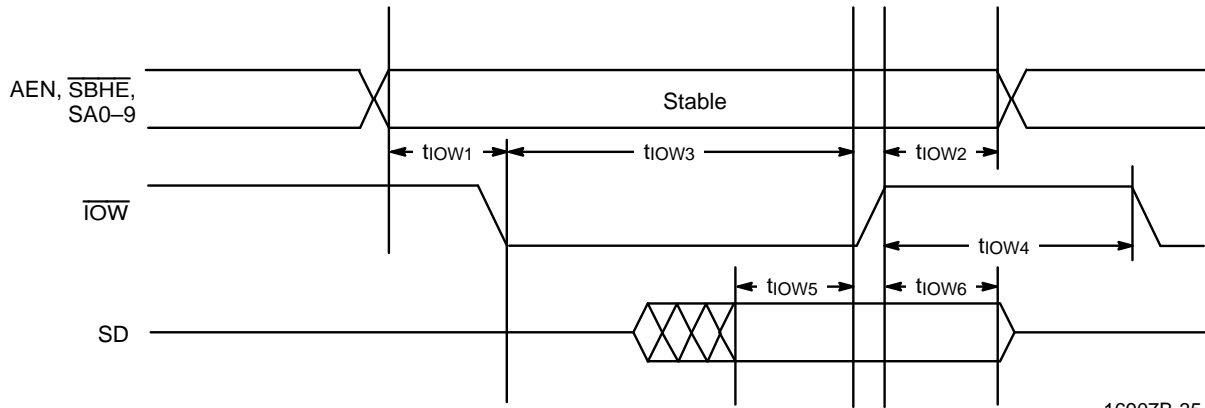

16907B-35

I/O Write without Wait States

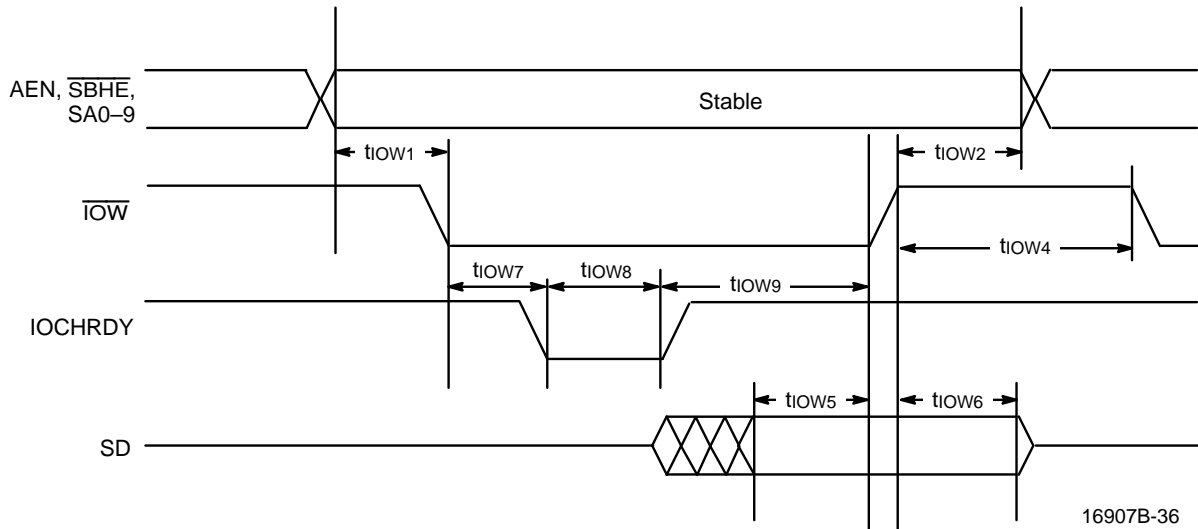

16907B-36

I/O Write with Wait States

SWITCHING WAVEFORMS: SHARED MEMORY MODE

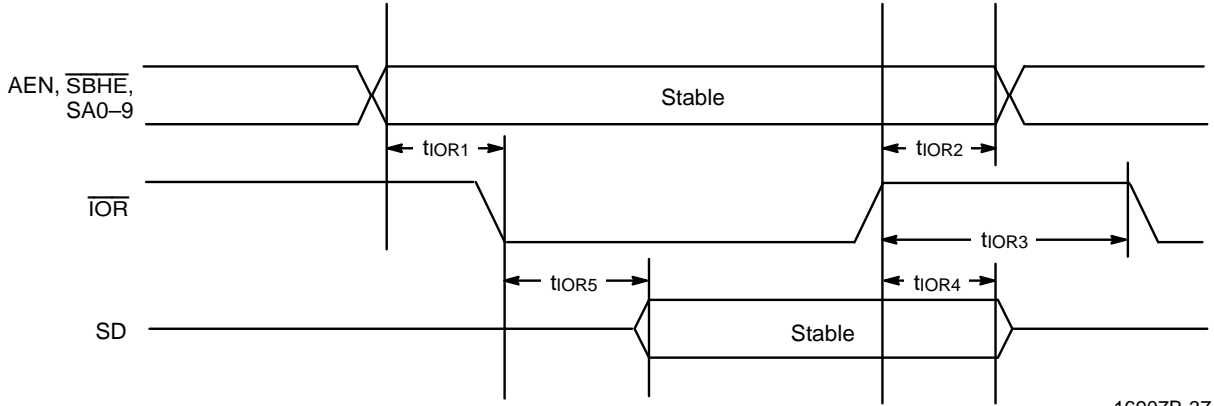

16907B-37

I/O Read without Wait States

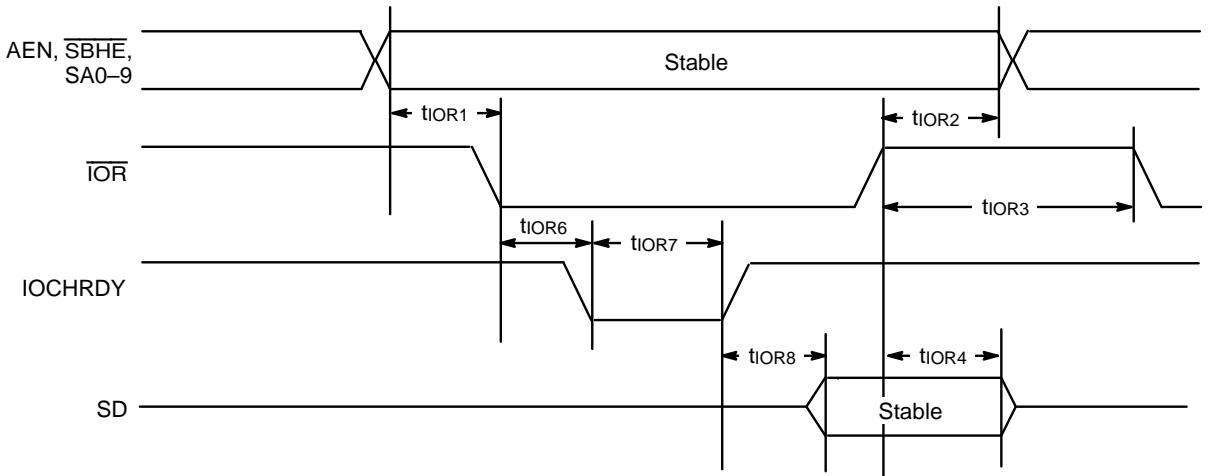

16907B-38

I/O Read with Wait States

SWITCHING WAVEFORMS: SHARED MEMORY MODE

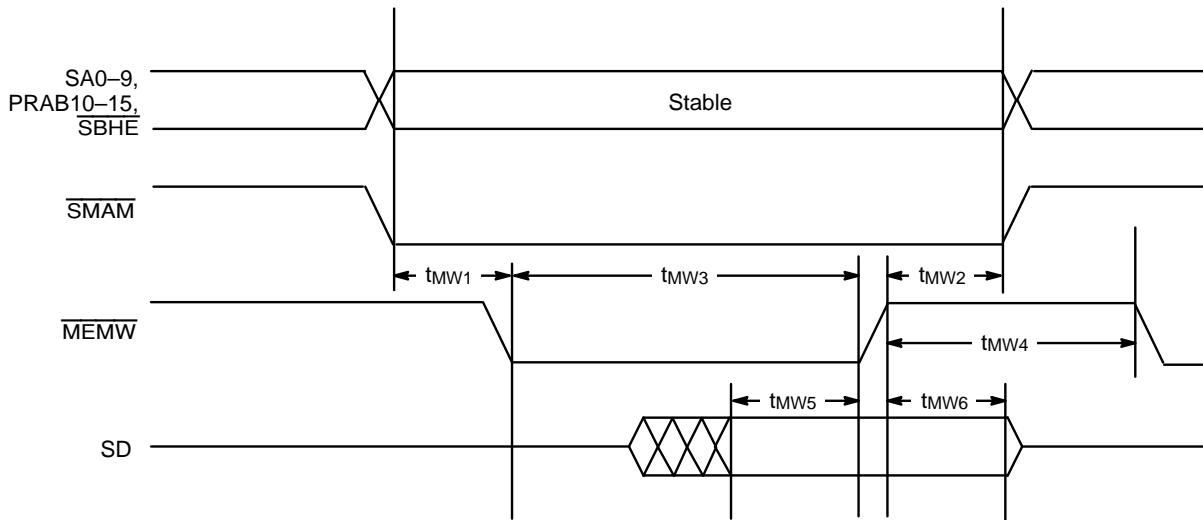

16907B-39

Memory Write without Wait States

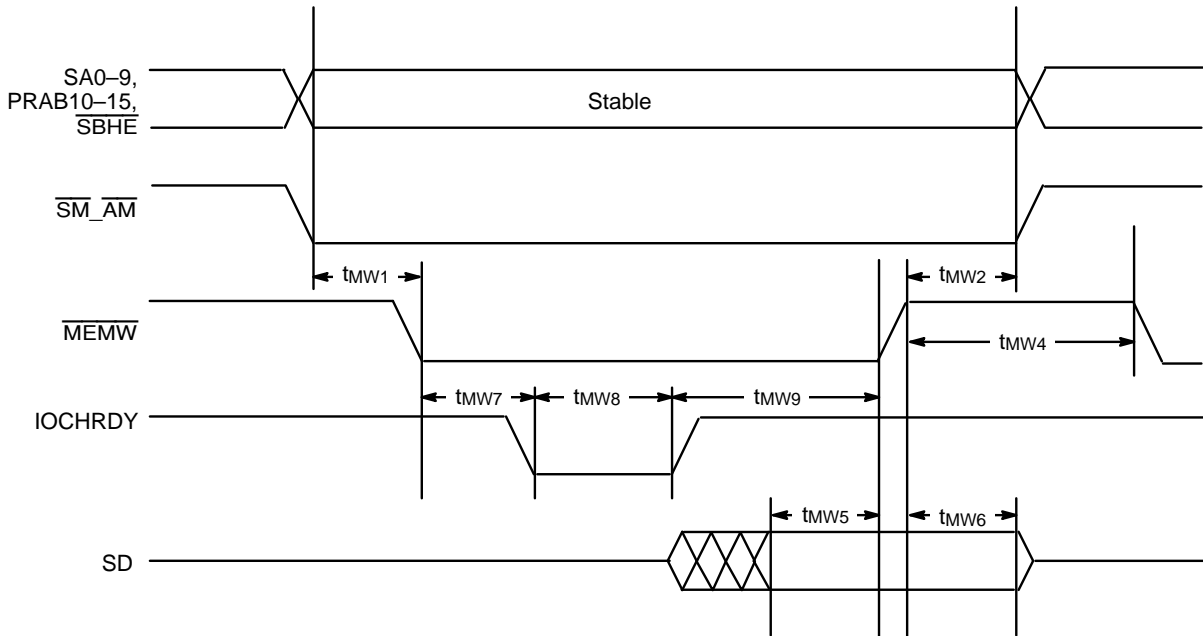

16907B-40

Memory Write with Wait States

SWITCHING WAVEFORMS: SHARED MEMORY MODE

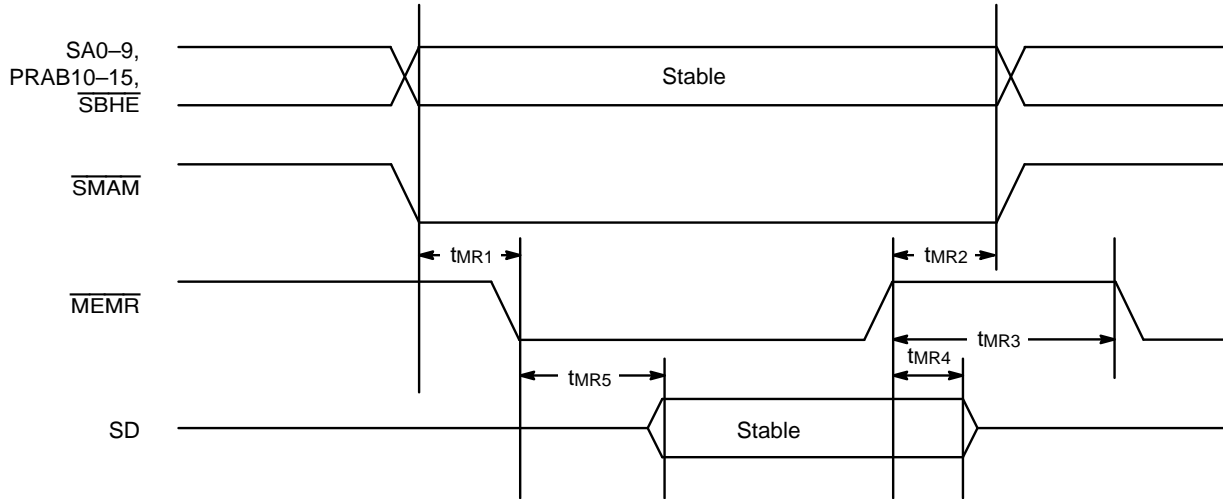

16907B-41

Memory Read without Wait States

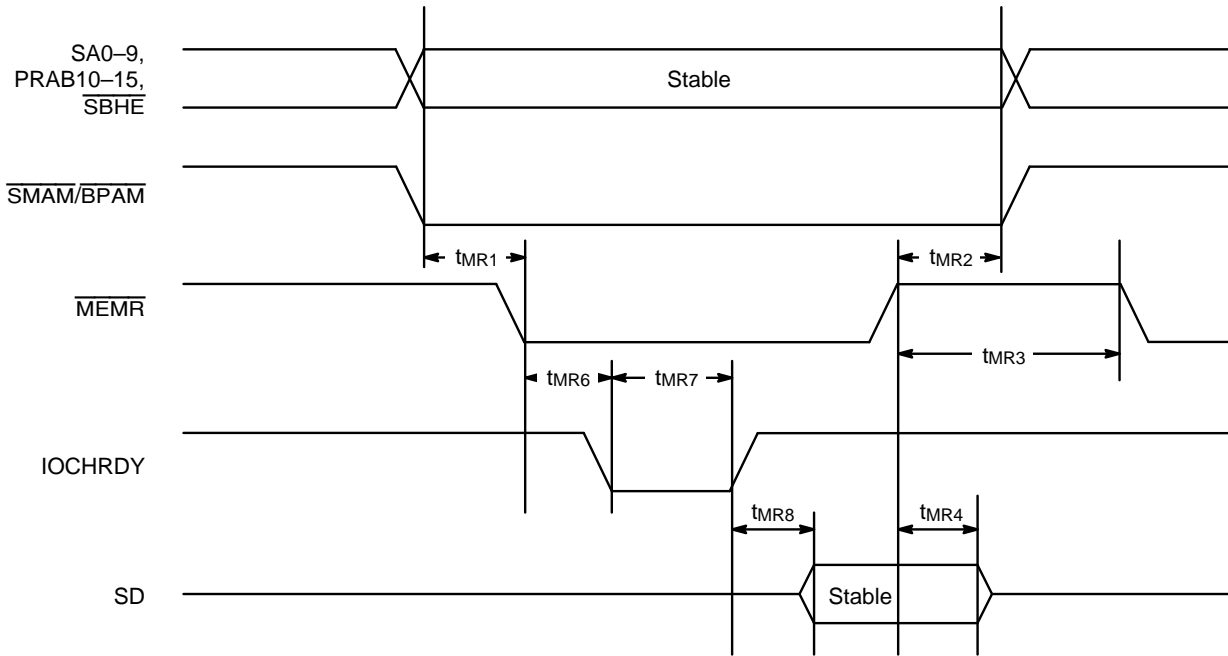

16907B-42

Memory Read with Wait States

SWITCHING WAVEFORMS: SHARED MEMORY MODE

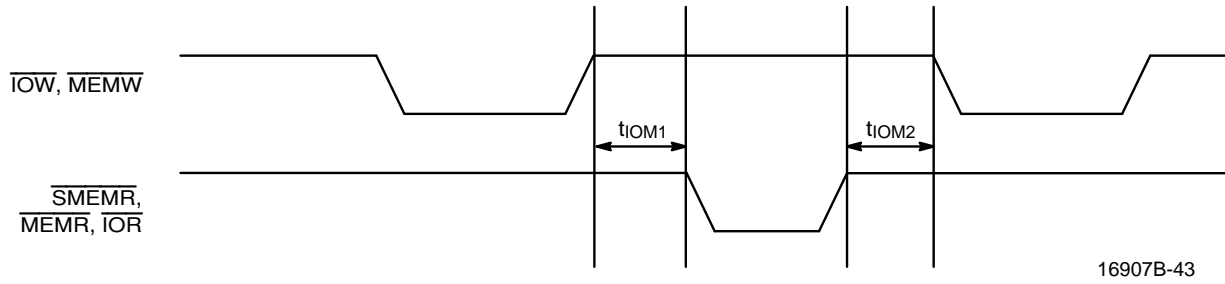

I/O to Memory Command Inactive Time

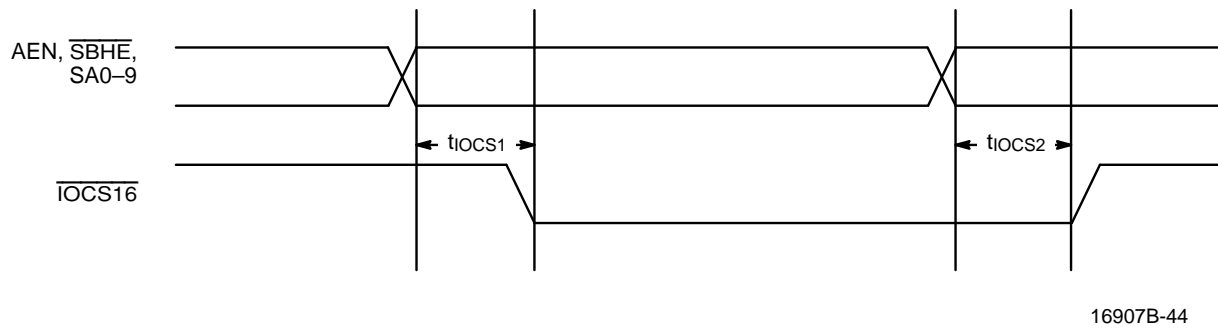

IOCS16 Timings

SWITCHING WAVEFORMS: SHARED MEMORY MODE

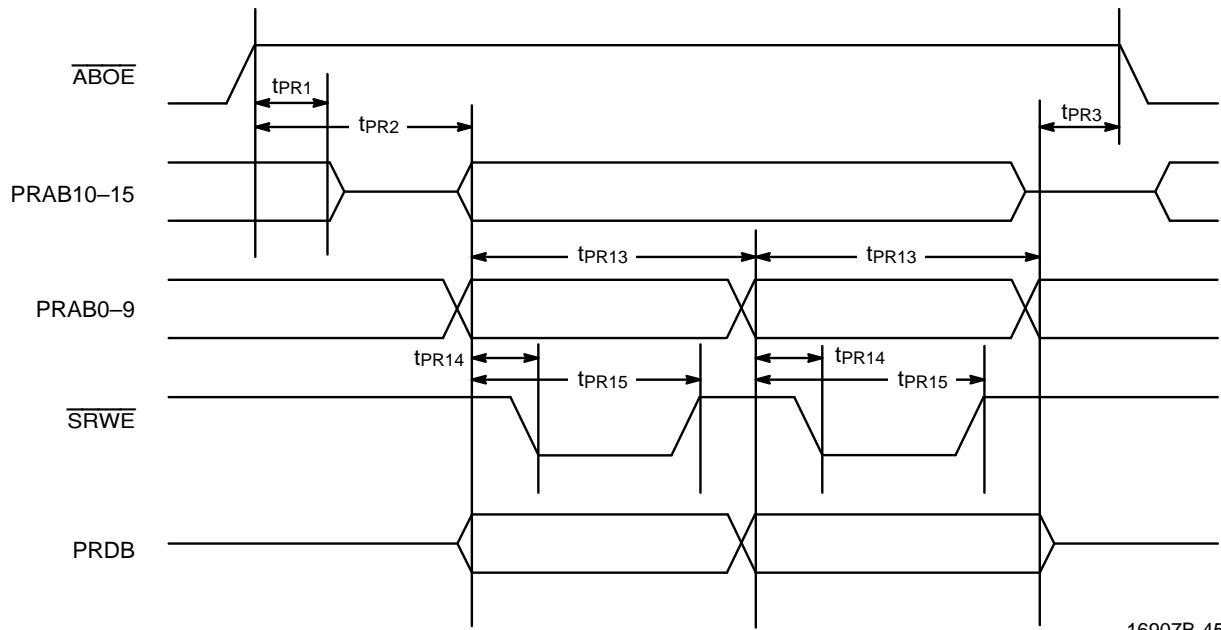

16907B-45

SRAM Write on Private Bus

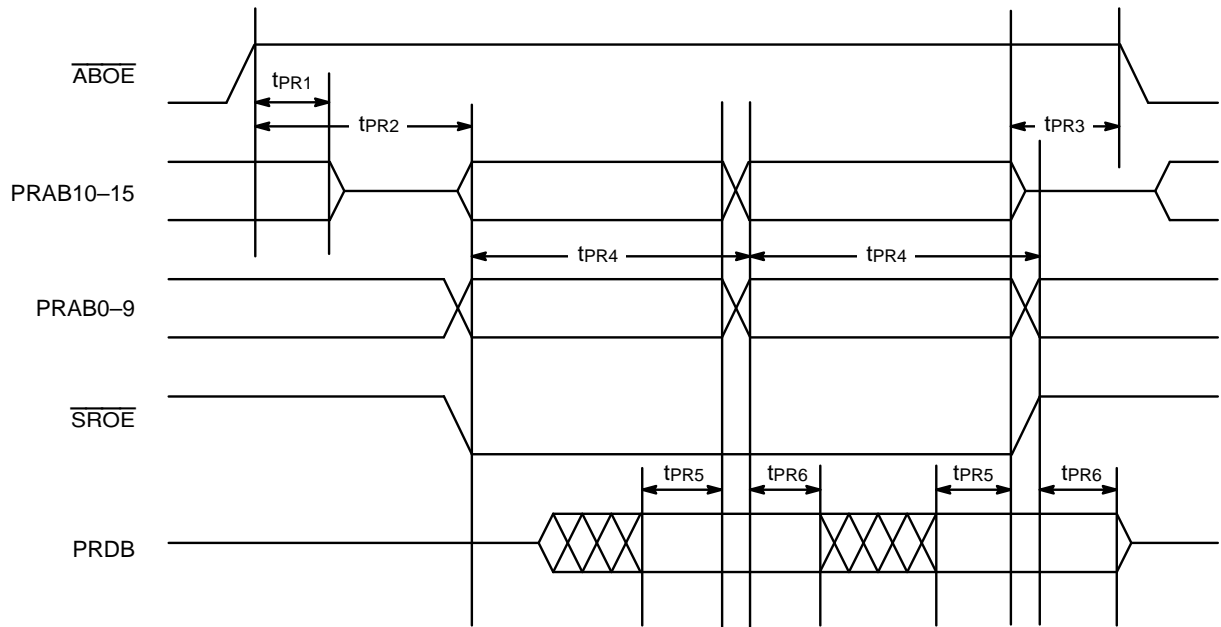

16907B-46

SRAM Read on Private Bus

SWITCHING WAVEFORMS: SHARED MEMORY MODE

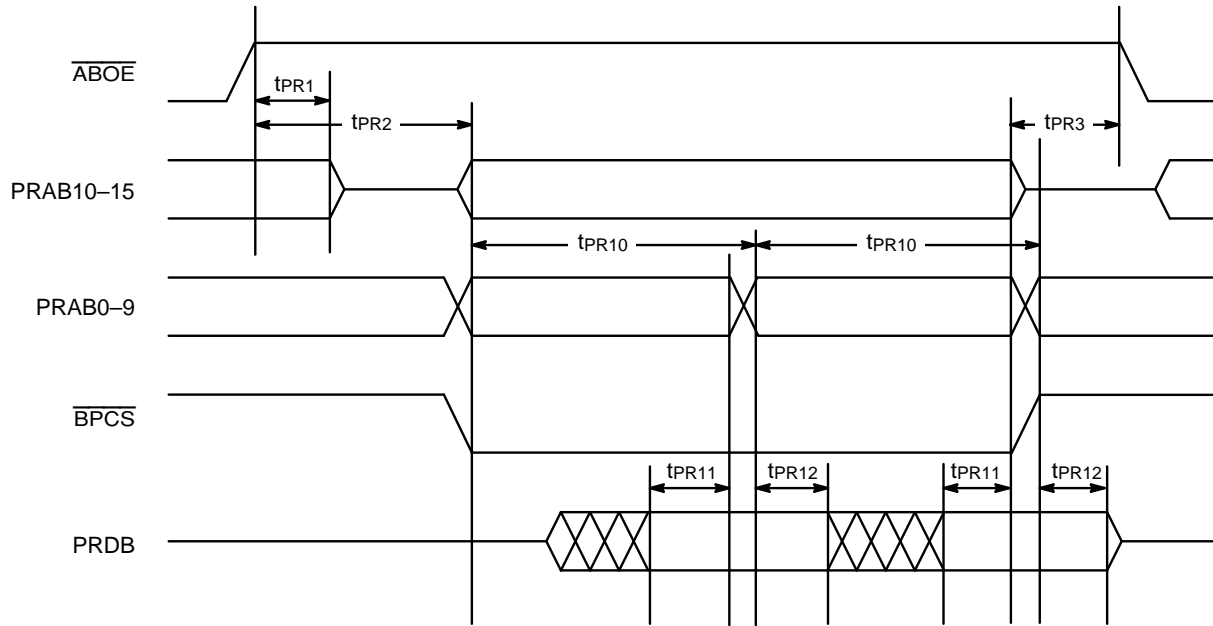

16907B-47

Boot PROM Read on Private Bus

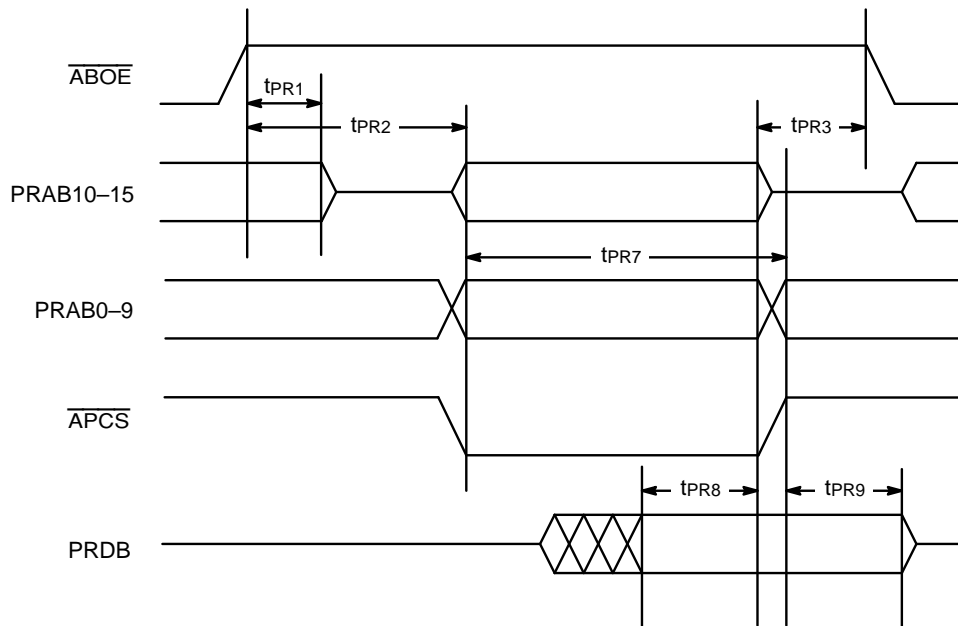

16907B-48

Address PROM Read on Private Bus

SWITCHING WAVEFORMS: GPSI

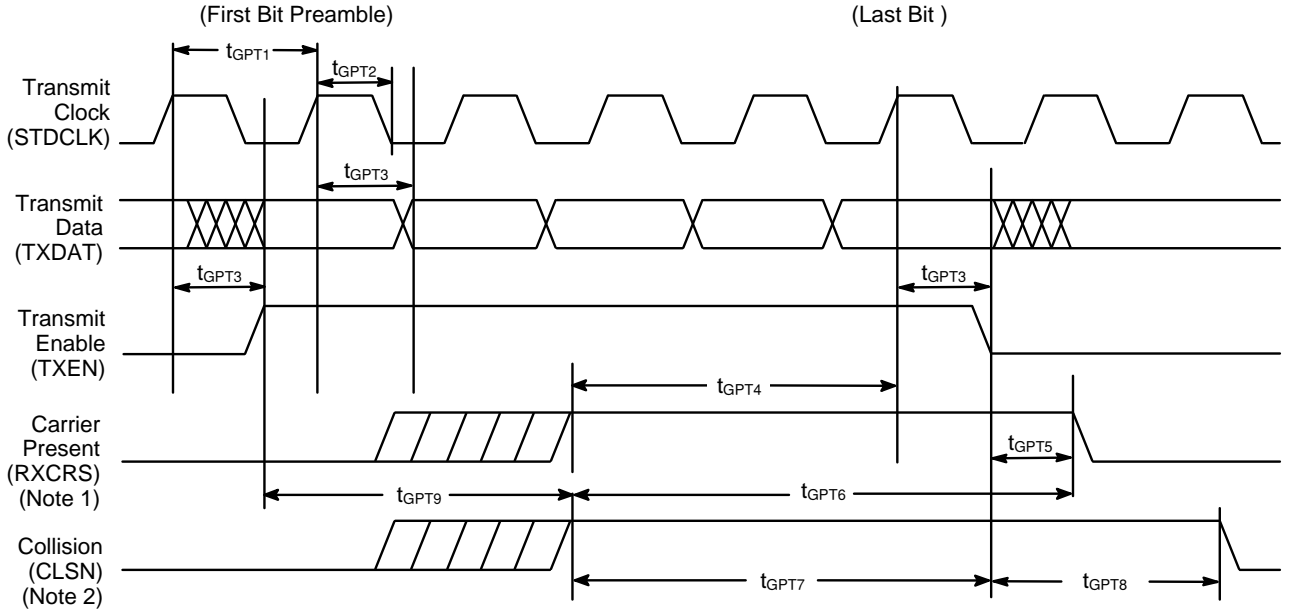

16907B-63

Notes:

1. If RXCRS is not present during transmission, LCAR bit in TMD3 will be set.
2. If CLSN is not present during or shortly after transmission, CERR in CSR0 will be set.

Transmit Timing

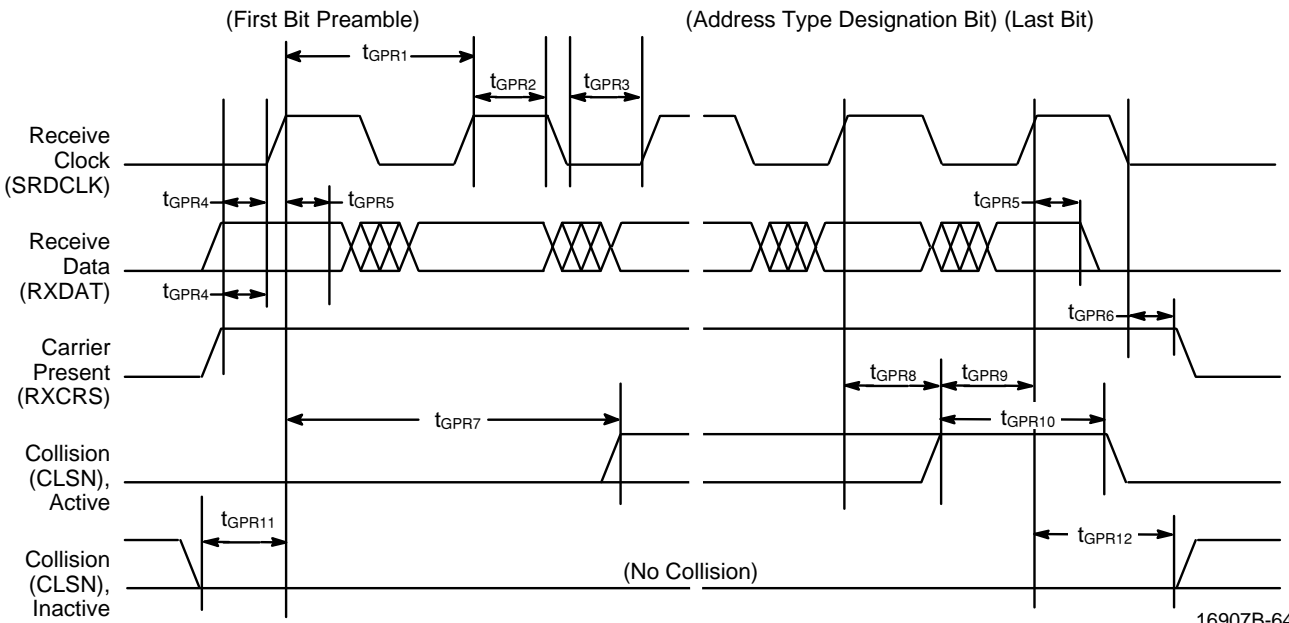

16907B-64

Receive Timing

SWITCHING WAVEFORMS: EADI

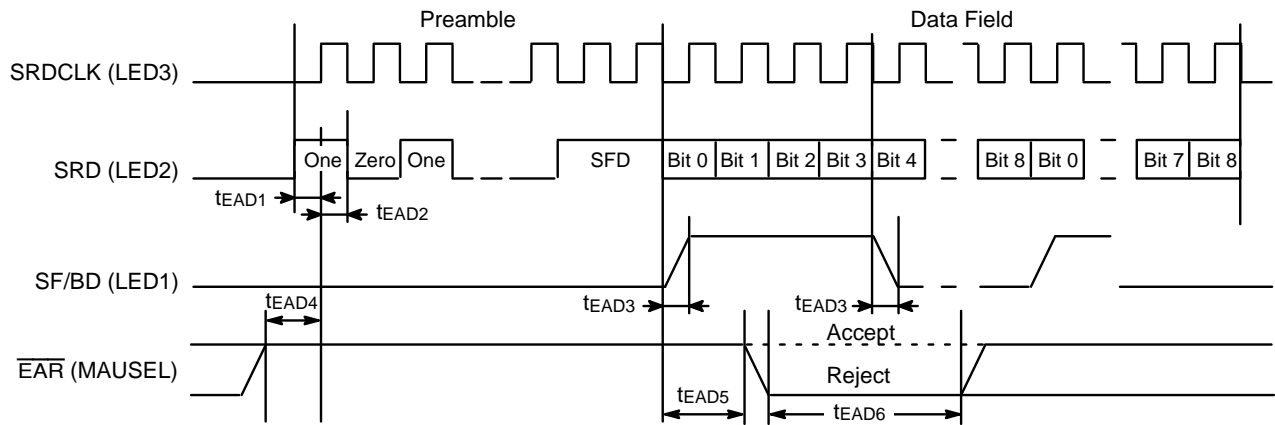

16907B-49

EADI Reject Timing

SWITCHING WAVEFORMS: JTAG (IEEE 1149.1) INTERFACE

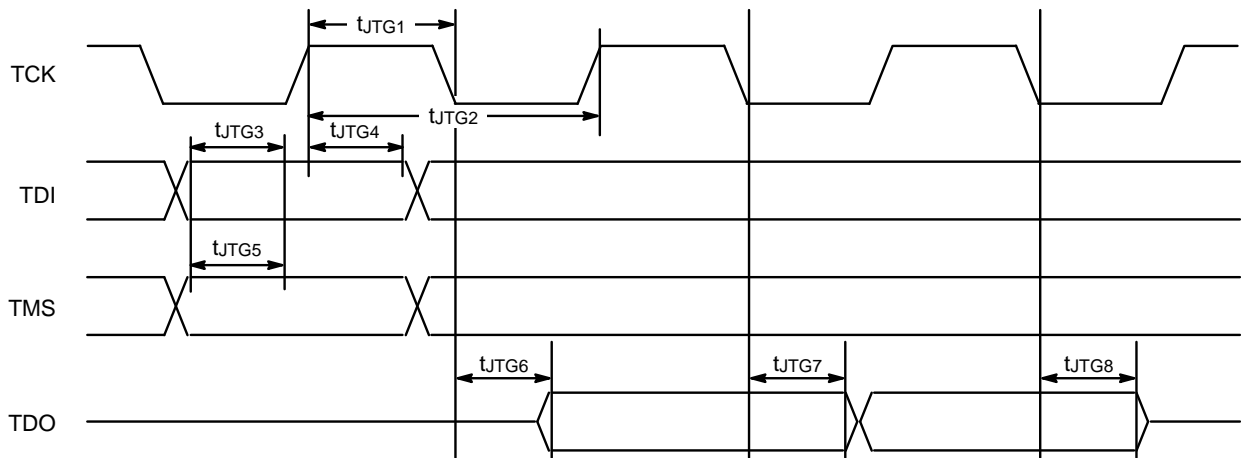

16907B-50

Test Access Port Timing

SWITCHING WAVEFORMS: AUI

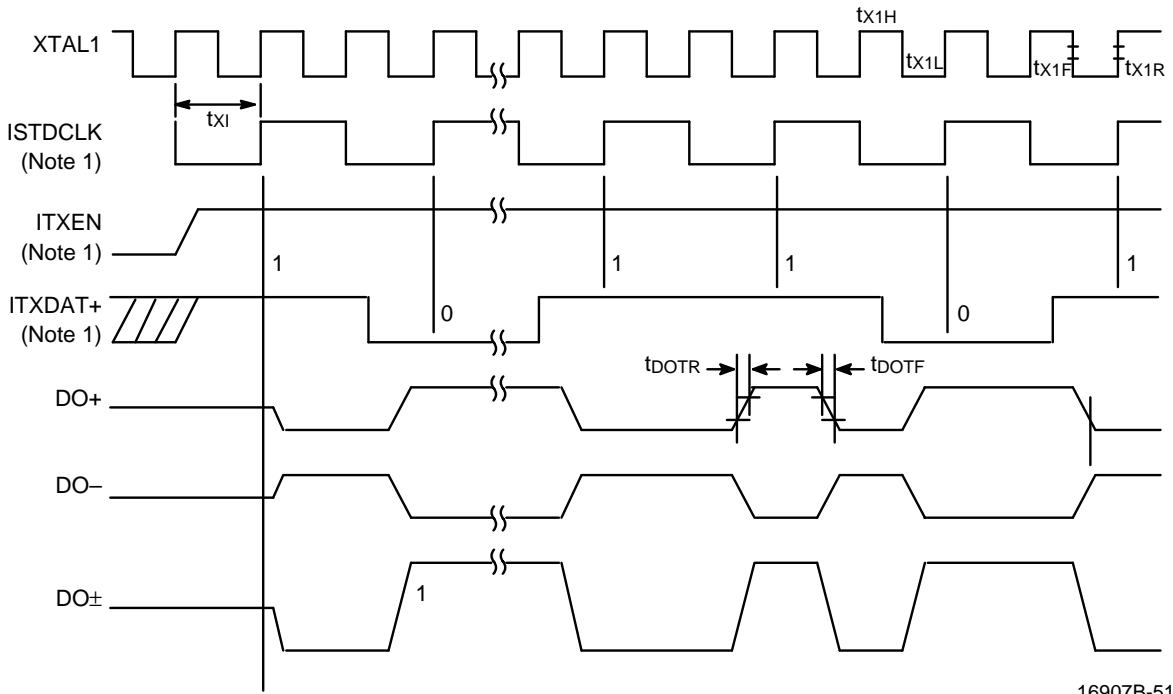

16907B-51

Note:

1. Internal signal and is shown for clarification only.

Transmit Timing—Start of Packet

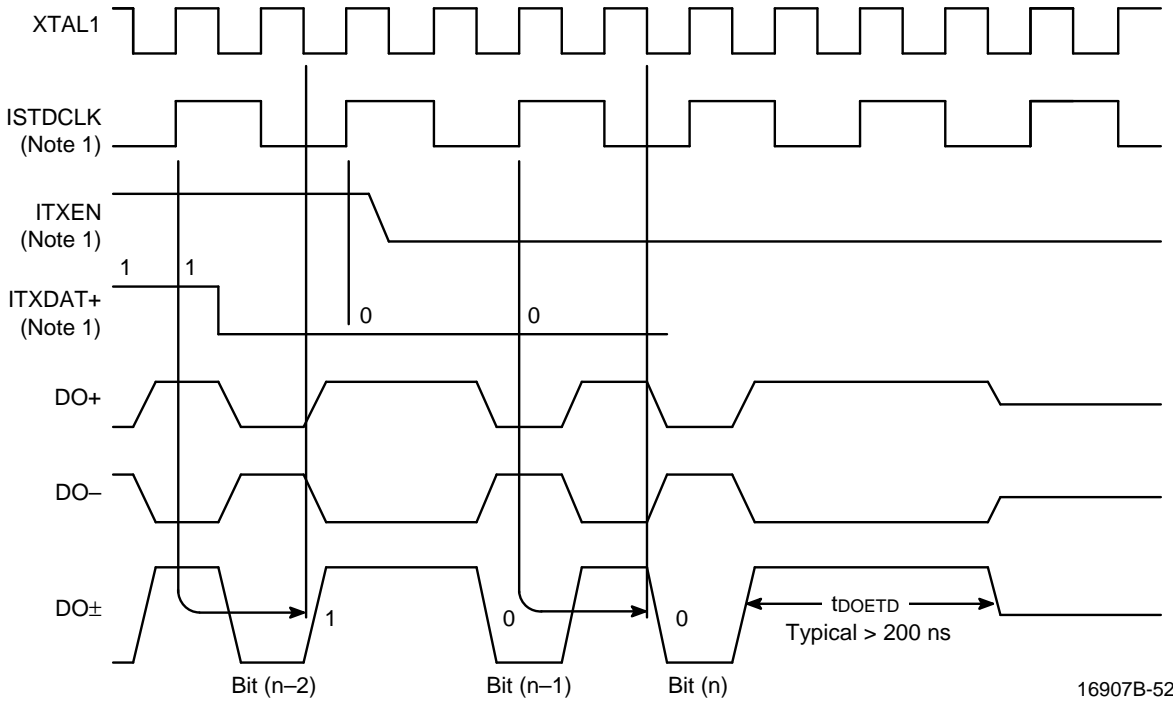

16907B-52

Note:

1. Internal signal and is shown for clarification only.

Transmit Timing—End of Packet (Last Bit = 0)

SWITCHING WAVEFORMS: AUI

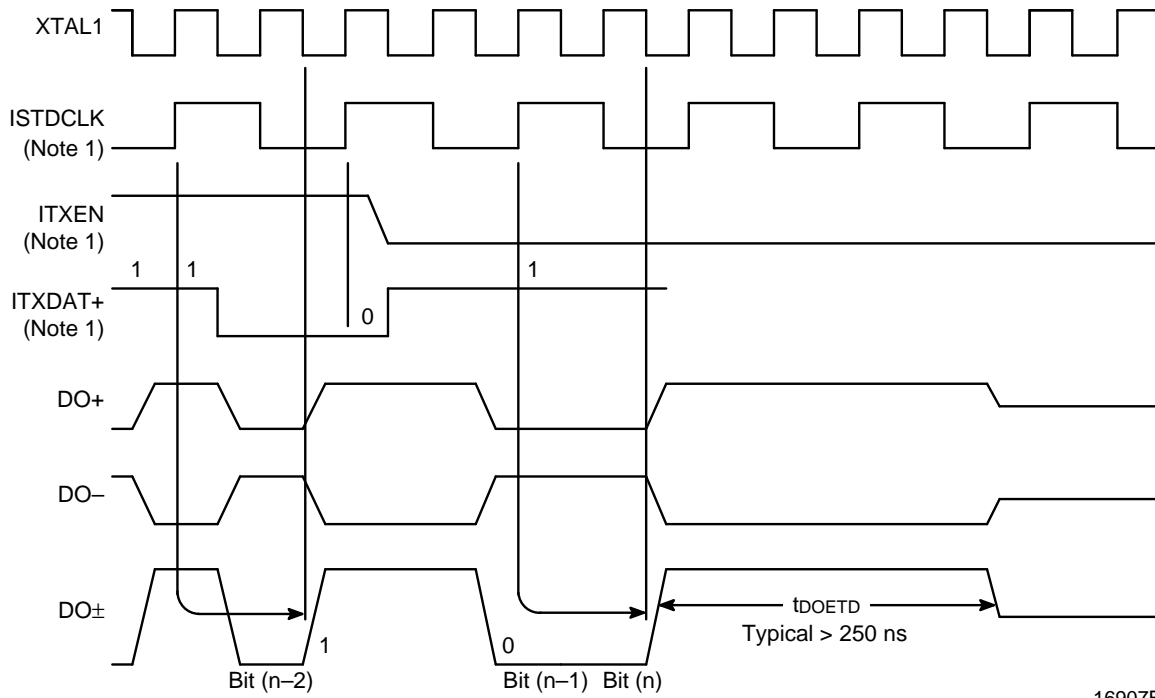

16907B-53

Note:
 1. Internal signal and is shown for clarification only.

Transmit Timing—End of Packet (Last Bit = 1)

SWITCHING WAVEFORMS: AUI

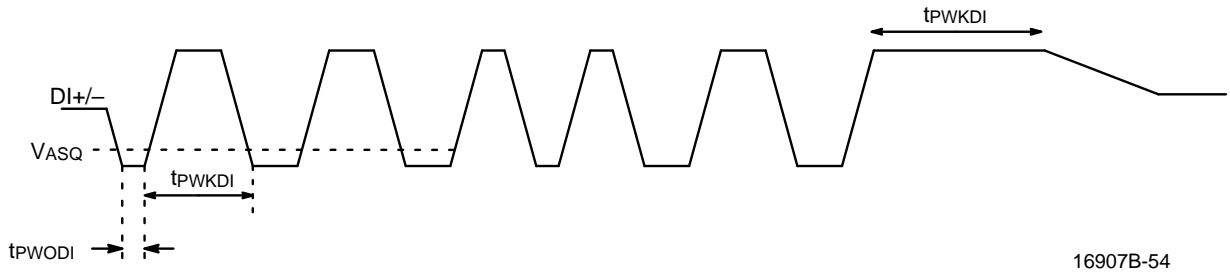

16907B-54

Receive Timing Diagram

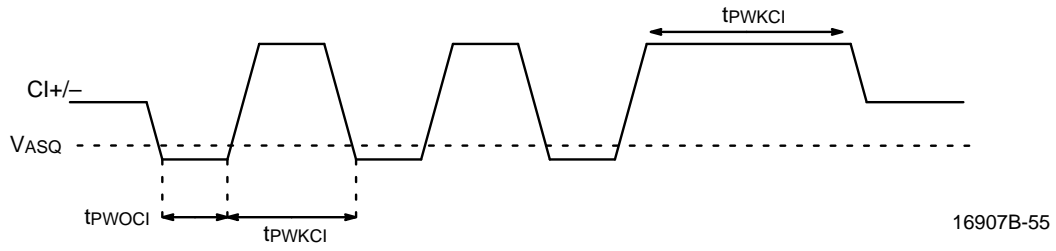

16907B-55

Collision Timing Diagram

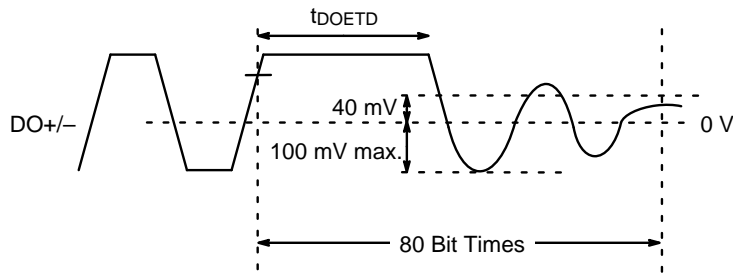

16907B-56

Port DO ETD Waveform

SWITCHING WAVEFORMS: 10BASE-T INTERFACE

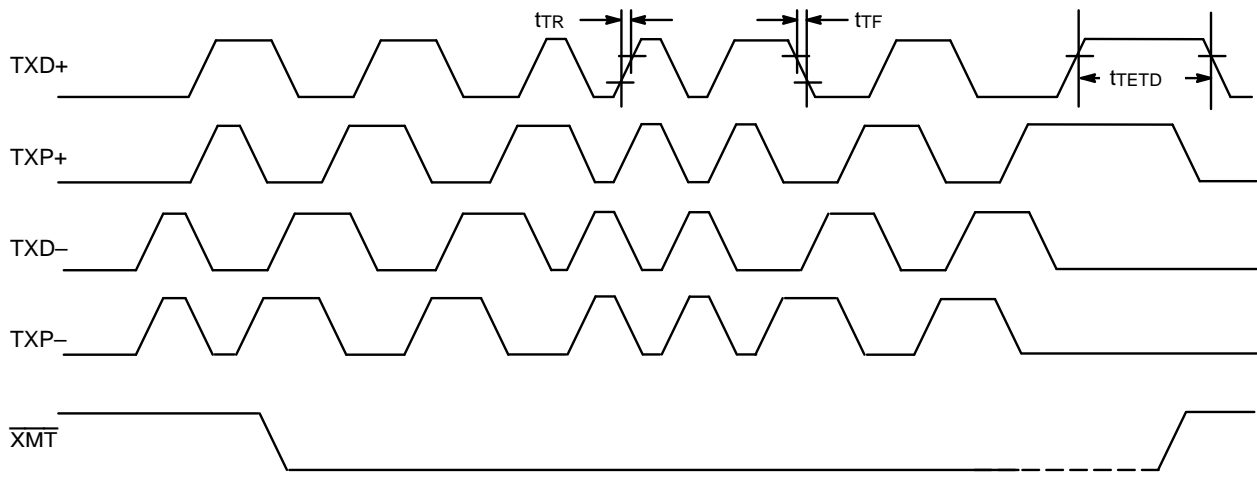

16907B-57

Transmit Timing

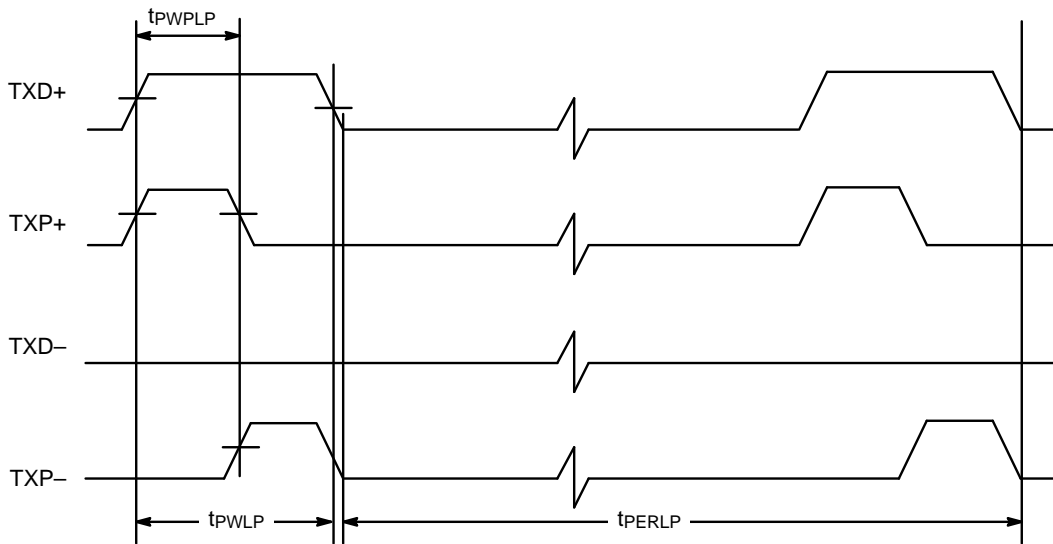

16907B-60

Idle Link Test Pulse

SWITCHING WAVEFORMS: 10BASE-T INTERFACE

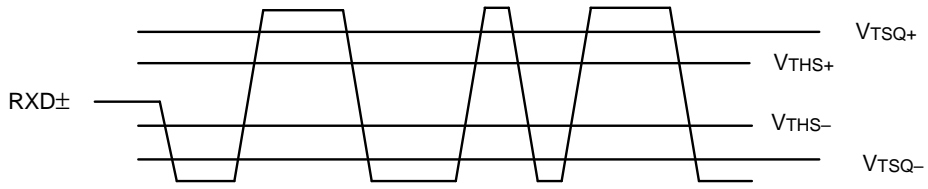

16907B-61

Receive Thresholds (LRT = 0; CSR15[9])

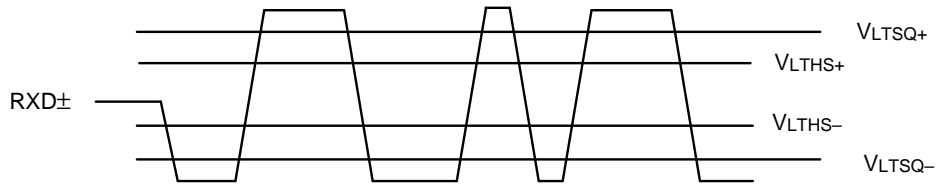

16907B-62

Receive Thresholds (LRT = 1; CSR15[9])



PCnet-ISA Compatible Media Interface Modules

PCnet-ISA COMPATIBLE 10BASE-T FILTERS AND TRANSFORMERS

The table below provides a sample list of PCnet-ISA compatible 10BASE-T filter and transformer modules

available from various vendors. Contact the respective manufacturer for a complete and updated listing of components.

Manufacturer	Part No.	Package	Filters and Transformers	Filters Transformers and Choke	Filters Transformers Dual Chokes	Filters Transformers Dual Chokes
Bel Fuse	A556-2006-DE	16-pin 0.3" DIL	√			
Bel Fuse	0556-2006-00	14-pin SIP	√			
Bel Fuse	0556-2006-01	14-pin SIP			√	
Bel Fuse	0556-6392-00	16-pin 0.5" DIL			√	
Halo Electronics	FD02-101G	16-pin 0.3" DIL	√			
Halo Electronics	FD12-101G	16-pin 0.3" DIL		√		
Halo Electronics	FD22-101G	16-pin 0.3" DIL			√	
PCA Electronics	EPA1990A	16-pin 0.3" DIL	√			
PCA Electronics	EPA2013D	16-pin 0.3" DIL		√		
PCA Electronics	EPA2162	16-pin 0.3" SIP			√	
Pulse Engineering	PE-65421	16-pin 0.3" DIL	√			
Pulse Engineering	PE-65434	16-pin 0.3" SIL			√	
Pulse Engineering	PE-65445	16-pin 0.3" DIL			√	
Pulse Engineering	PE-65467	12-pin 0.5" SMT				√
Valor Electronics	PT3877	16-pin 0.3" DIL	√			
Valor Electronics	FL1043	16-pin 0.3" DIL			√	

PCnet-ISA Compatible AUI Isolation Transformers

The table below provides a sample list of PCnet-ISA compatible AUI isolation transformers available from

various vendors. Contact the respective manufacturer for a complete and updated listing of components.

Manufacturer	Part No.	Package	Description
Bel Fuse	A553-0506-AB	16-pin 0.3" DIL	50 μ H
Bel Fuse	S553-0756-AE	16-pin 0.3" SMD	75 μ H
Halo Electronics	TD01-0756K	16-pin 0.3" DIL	75 μ H
Halo Electronics	TG01-0756W	16-pin 0.3" SMD	75 μ H
PCA Electronics	EP9531-4	16-pin 0.3" DIL	50 μ H
Pulse Engineering	PE64106	16-pin 0.3" DIL	50 μ H
Pulse Engineering	PE65723	16-pin 0.3" SMT	75 μ H
Valor Electronics	LT6032	16-pin 0.3" DIL	75 μ H
Valor Electronics	ST7032	16-pin 0.3" SMD	75 μ H



PCnet-ISA Compatible DC/DC Converters

The table below provides a sample list of PCnet-ISA compatible DC/DC converters available from various

vendors. Contact the respective manufacturer for a complete and updated listing of components.

Manufacturer	Part No.	Package	Voltage	Remote On/Off
Halo Electronics	DCU0-0509D	24-pin DIP	5/-9	No
Halo Electronics	DCU0-0509E	24-pin DIP	5/-9	Yes
PCA Electronics	EPC1007P	24-pin DIP	5/-9	No
PCA Electronics	EPC1054P	24-pin DIP	5/-9	Yes
PCA Electronics	EPC1078	24-pin DIP	5/-9	Yes
Valor Electronics	PM7202	24-pin DIP	5/-9	No
Valor Electronics	PM7222	24-pin DIP	5/-9	Yes

MANUFACTURER CONTACT INFORMATION

Contact the following companies for further information on their products:

Company		U.S. and Domestic	Asia	Europe
Bel Fuse	Phone:	(201) 432-0463	852-328-5515	33-1-69410402
	FAX:	(201) 432-9542	852-352-3706	33-1-69413320
Halo Electronics	Phone:	(415) 969-7313	65-285-1566	
	FAX:	(415) 367-7158	65-284-9466	
PCA Electronics (HPC in Hong Kong)	Phone:	(818) 892-0761	852-553-0165	33-1-44894800
	FAX:	(818) 894-5791	852-873-1550	33-1-42051579
Pulse Engineering	Phone:	(619) 674-8100	852-425-1651	353-093-24107
	FAX:	(619) 675-8262	852-480-5974	353-093-24459
Valor Electronics	Phone:	(619) 537-2500	852-513-8210	49-89-6923122
	FAX:	(619) 537-2525	852-513-8214	49-89-6926542



Recommendation for Reducing Noise Injection

DECOUPLING LOW-PASS R/C FILTER DESIGN

The PCnet-ISA controller is an integrated, single-chip Ethernet controller, which contains both digital and analog circuitry. The analog circuitry contains a high speed Phase-Locked Loop (PLL) and Voltage Controlled Oscillator (VCO). Because of the mixed signal characteristics of this chip, some extra precautions must be taken into account when designing with this device.

Described in this section is a simple decoupling low-pass R/C filter that can significantly increase noise immunity of the PLL circuit, thus, prevent noise from disrupting the VCO. Bit error rate, a common measurement of network performance, as a result can be drastically reduced. In certain cases the bit error rate can be reduced by orders of magnitude.

Implementation of this filter is not necessary to achieve a functional product that meets the IEEE 802.3 specification and provides adequate performance. However, this filter will help designers meet those specifications with more margin.

Digital Decoupling

The DVSS pins that are sinking the most current are those that provide the ground for the ISA bus output signals since these outputs require 24 mA drivers. The DVSS10 and DVSS12 pins provide the ground for the internal digital logic. In addition, DVSS11 provides ground for the internal digital and for the Input and I/O pins.

The CMOS technology used in fabricating the PCnet-ISA controller employs an n-type substrate. In this technology, all V_{DD} pins are electrically connected to each other internally. Hence, in a 4-layer board, when decoupling between V_{DD} and critical V_{SS} pins, the specific V_{DD} pin that you connect to is not critical. In fact, the V_{DD} connection of the decoupling capacitor can be made directly to the power plane, near the closest V_{DD} pin to the V_{SS} pin of interest. However, we recommend that the V_{SS} connection of the decoupling capacitor be made directly to the V_{SS} pin of interest as shown.

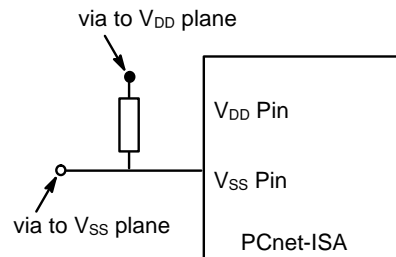

AMD recommends that at least one low-frequency bulk decoupling capacitor be used in the area of the PCnet-ISA controller. 22 μF capacitors have worked well for this. In addition, a total of 4 or 5 0.1 μF capacitors have proven sufficient around the DV_{SS} and DV_{DD} pins that supply the drivers of the ISA bus output pins.

Analog Decoupling

The most critical pins are the analog supply and ground pins. All of the analog supply and ground pins are located in one corner of the device. Specific requirements of the analog supply pins are listed below.

AVSS1 and AVDD3

These pins provide the power and ground for the Twisted Pair and AUJ drivers. Hence, they are very noisy. A dedicated 0.1 μF capacitor between these pins is recommended.

AVSS2 and AVDD2

These pins are the most critical pins on the PCnet-ISA controller because they provide the power and ground for the PLL portion of the chip. The VCO portion of the PLL is sensitive to noise in the 60–200 kHz. range. To prevent noise in this frequency range from disrupting the VCO, AMD strongly recommends that the low-pass filter shown below be implemented on these pins. Tests using this filter have shown significantly increased noise immunity and reduced Bit Error Rate (BER) statistics in designs using the PCnet-ISA controller.

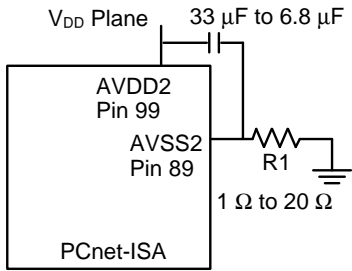

To determine the value for the resistor and capacitor, the formula is:

$$R * C \geq 88$$

Where R is in ohms and C is in microfarads. Some possible combinations are given below. To minimize the

voltage drop across the resistor, the R value should not be more than 20 Ω .

R	C
2.7 Ω	33 μF
4.3 Ω	22 μF
6.8 Ω	15 μF
10 Ω	10 μF
20 Ω	6.8 μF

AVSS2 and AVDD2/AVDD4

These pins provide power and ground for the AUI and twisted pair receive circuitry. No specific decoupling has been necessary on these pins.



Alternative Method for Initialization

The PCnet-ISA controller may be initialized by performing I/O writes only. That is, data can be written directly to the appropriate control and status registers (CSR) instead of reading from the Initialization Block in memory. The registers that must be written are shown in the table below. These are followed by writing the START bit in CSR0.

Control and Status Register	Comment
CSR8	LADRF[15:0]
CSR9	LADRF[31:16]
CSR10	LADRF[47:32]
CSR11	LADRF[63:48]
CSR12	PADR[15:0]
CSR13	PADR[31:16]
CSR14	PADR[47:32]
CSR15	Mode
CSR24-25	BADR
CSR30-31	BADX
CSR47	POLLINT
CSR76	RCVRL
CSR78	XMTRL

Note: The INIT bit must not be set or the initialization block will be accessed instead.

Copyright © Each Manufacturing Company.

All Datasheets cannot be modified without permission.

This datasheet has been download from :

www.AllDataSheet.com

100% Free DataSheet Search Site.

Free Download.

No Register.

Fast Search System.

www.AllDataSheet.com