

3.4 V, 1.2 W RF Power Amplifier IC

V 1.0

MA02107AF

Features

- Ideal for Pager Applications
- +30.8 dBm Output Power
- 30.8 dB Power Gain
- Single Positive Supply
- Class AB Bias
- 50 Ohm Input Impedance
- Single Capacitor Output Match

Functional Schematic

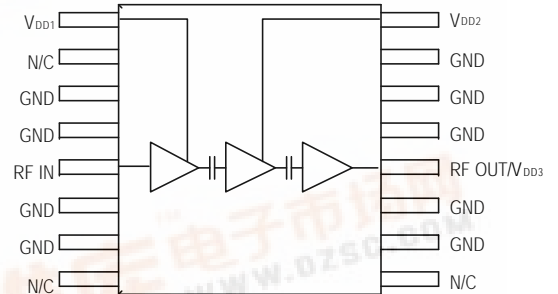

Description

The MA02107AF is a three stage power amplifier, designed for paging applications to have an output power of +30.8 dBm with an input power of 0 dBm. This power amplifier operates at +3.4 volts with 55% typical power added efficiency. The MA02107AF is mounted in a standard outline 16-pin TSSOP plastic package.

The MA02107AF is fabricated using M/A-COM's self-aligned MSAG[®]-Lite MESFET process for a low single supply voltage, high power efficiency, and excellent reliability.

Pin Configuration

Pin	Function	Description
1	V _{DD1}	First Stage Supply Voltage
2	N/C	Not Connected
3	GND	Ground
4	GND	Ground
5	RF _{IN}	RF Input
6	GND	Ground
7	GND	Ground
8	N/C	Not Connected
9	N/C	Not Connected
10	GND	Ground
11	GND	Ground
12	RF _{OUT} /V _{DD3}	RF Output/Third Stage Supply
13	GND	Ground
14	GND	Ground
15	GND	Ground
16	V _{DD2}	Second Stage Supply Voltage

Ordering Information

Part Number	Description
MA02107AF-R7	7 inch, 1000 piece reel
MA02107AF-R13	13 inch, 3000 piece reel
MA02107AF-SMB	Sample Test Board

Specifications subject to change without notice.

- North America: Tel. (800) 366-2266
- Asia/Pacific: Tel.+81-44-844-8296, Fax +81-44-844-8298
- Europe: Tel. +44 (1344) 869 595, Fax+44 (1344) 300 020

tyco Electronics

M/A-COM

Electrical Specifications: $T_s = 35\text{ }^\circ\text{C}^1$, $Z_0 = 50\text{ }\Omega^{2,3}$

Parameter	Test Conditions	Units	Min	Typ	Max
Frequency		MHz	900		942
Output Power		dBm	30.0	30.8	
Power Gain		dB		30.8	
Power Added Efficiency		%	45	55	
Input Return Loss		dB	10	15	
2 nd Harmonics		dBc		-35	-29
3 rd Harmonics		dBc		-50	-45
Thermal Resistance	3 rd Stage FET to solder point of pin 13	$^\circ\text{C}/\text{W}$		41	
Stability	+3.0 V < V_{CC} < +5.0 V, P_{OUT} < +31 dBm, VSWR < 5:1, -40°C < T_C < $+85^\circ\text{C}$, RBW = 3 MHz max hold		All spurs < -60 dBc		

1. T_s is the temperature measured at the soldering point of pin 13.
2. Unless otherwise specified, input power is 0 dBm, V_{DD} is +3.45 V, and test frequency is 900 MHz.
3. The output is externally matched to 50 ohms.

Absolute Maximum Ratings¹

Parameter	Absolute Maximum
Max Input Power	+6 dBm
Operating Voltages	+5.0 volts
Operating Temperature, T_s	$-40\text{ }^\circ\text{C}$ to $+70\text{ }^\circ\text{C}$
Channel Temperature	$+150\text{ }^\circ\text{C}$
Storage Temperature	$-40\text{ }^\circ\text{C}$ to $+150\text{ }^\circ\text{C}$

1. Exceeding any one or combination of these limits may cause permanent damage.

Application Information

Static Sensitivity

Gallium arsenide integrated circuits are ESD sensitive and can be damaged by static electricity. Use proper ESD precautions when handling these devices.

Board Layout

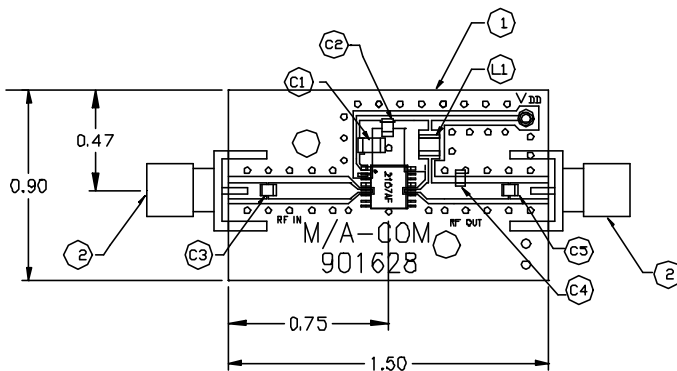

Sample Test Board

Specifications subject to change without notice.

- North America: Tel. (800) 366-2266
- Asia/Pacific: Tel.+81-44-844-8296, Fax +81-44-844-8298
- Europe: Tel. +44 (1344) 869 595, Fax+44 (1344) 300 020

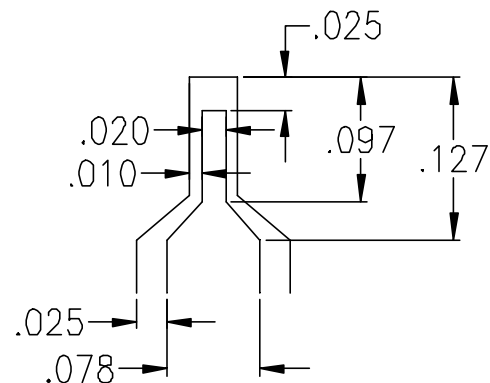

50 Ohm Lead Transition

Output Match Impedance (as seen from pin 12)

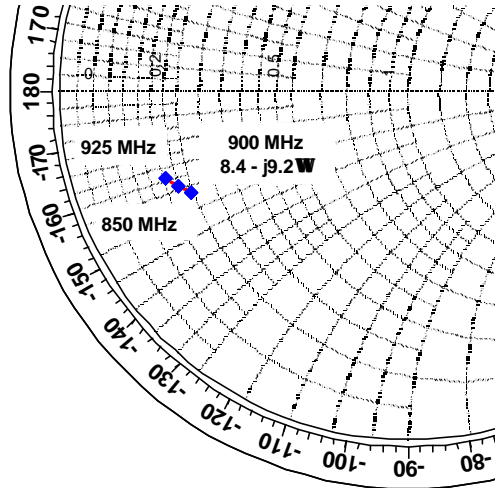

Typical Performance Curves

Output Power and PAE vs. Input Power

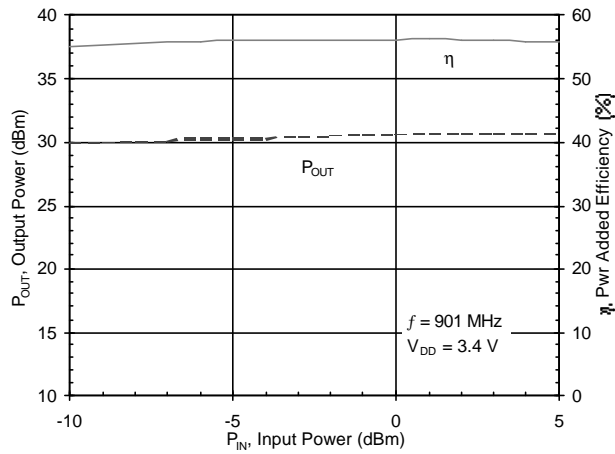

Output Power, PAE, and VSWR vs. Frequency

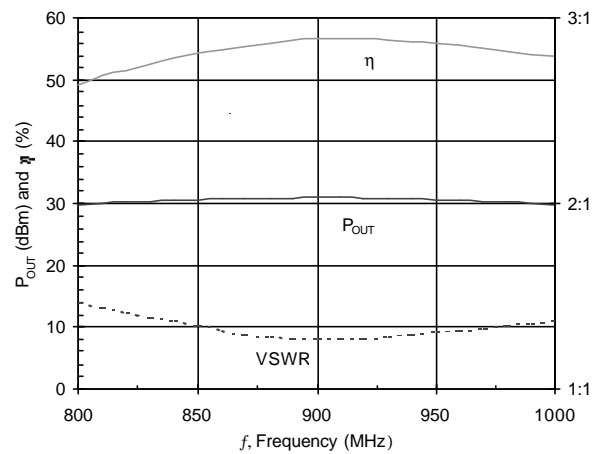

Output Power and PAE vs. Supply Voltage

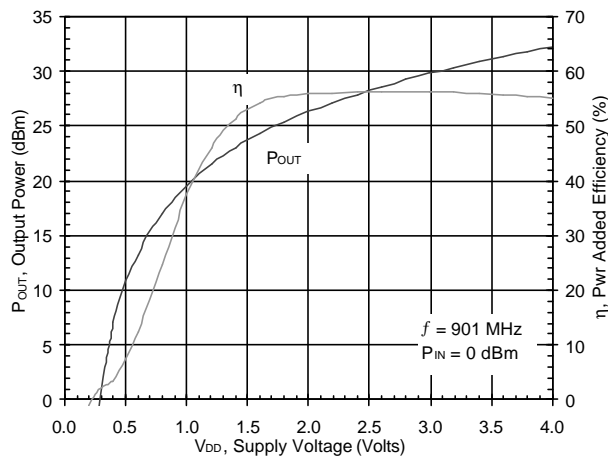

Harmonics

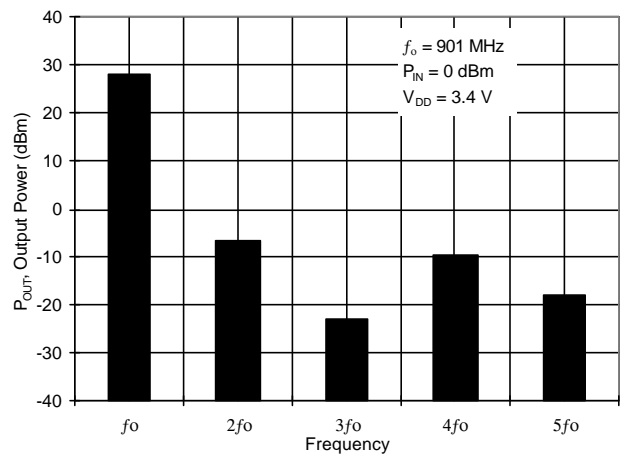

Specifications subject to change without notice.

- North America: Tel. (800) 366-2266
- Asia/Pacific: Tel.+81-44-844-8296, Fax +81-44-844-8298
- Europe: Tel. +44 (1344) 869 595, Fax+44 (1344) 300 020

Application Schematic

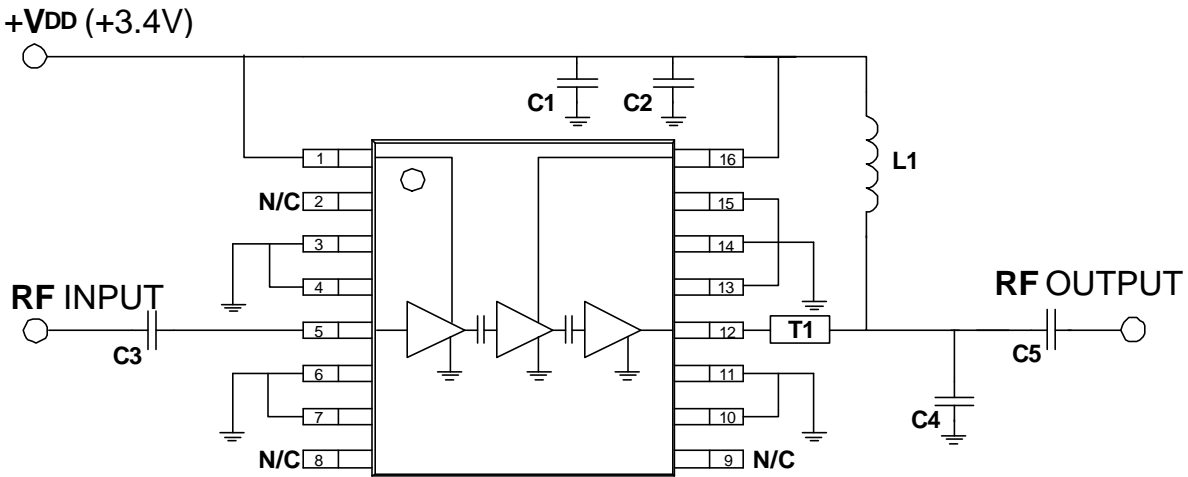

List of components:

- C1 = 0.1µF Kemet multilayer ceramic chip capacitor (C1206C104K5RAC)
- C2 = 4700 pF Kemet multilayer ceramic chip capacitor (C0805C472K5RAC)
- C4 = 6.8 pF DLI multilayer ceramic chip capacitor (C11AH7R5B5TXL)
- C3 = C5 = 100 pF DLI multilayer ceramic chip capacitor (DC Block; C11AH101K5TXL)
- L1 = 39 nH Coilcraft chip inductor (1008CS.390XMBB)
- T1 = 0.19" of 50 ohm grounded coplanar waveguide (60 mil GETEK board)

TSSOP-16 Package

SYMBOL	Dimensions in millimeters			Dimensions in inches		
	MIN	NOM	MAX	MIN	NOM	MAX
A	1.05	1.10	1.20	0.041	0.043	0.047
A1	0.05	0.10	0.15	0.002	0.004	0.006
A2	—	1.00	1.05	—	0.039	0.041
b	0.20	0.25	0.28	0.008	0.010	0.011
C	—	0.127	—	—	0.005	—
D	4.90	5.075	5.10	0.193	0.200	0.201
E	6.20	6.40	6.60	0.244	0.252	0.260
E1	4.30	4.40	4.50	0.169	0.173	0.177
e	—	0.65	—	—	0.025	—
L	0.50	0.60	0.70	0.020	0.024	0.028
L1	0.90	1.00	1.10	0.035	0.039	0.043
y	—	—	0.10	—	—	0.004
θ	0°	4°	8°	0°	4°	8°

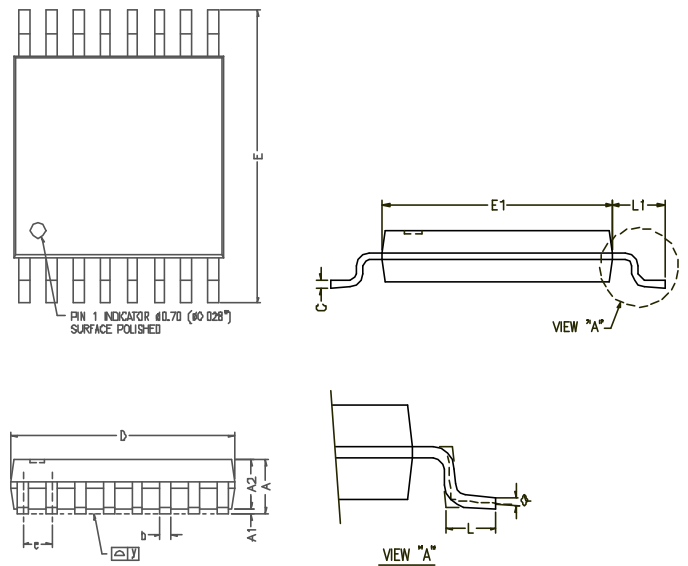

NOTES:

1. Controlling dimension: mm
2. Lead frame material: EFTEC 64
3. Dimension "D" does not include mold flash, protrusions or gate burrs
4. Dimension "E" does not include interlead flash or protrusions
5. Tolerance: ±0.254 mm (±0.010") unless otherwise specified
6. End flash max: 0.12 mm (0.005")

Specifications subject to change without notice.

North America: Tel. (800) 366-2266