

# PA-MACH210-Q06T Data Sheet

44 pin QFP socket/28 pin DIP 0.6" plug

## Supported Device/Footprints

Using this adapter, the AMD MACH110, 210 & 215 in the QFP package can be programmed on DIP programmers.

Mfgr	Device	Package	Device	Footprint Plug
AMD	MACH 110, 210 & 215	QFP	MACH 110, 210 & 215	AMD spec'd 28 DIP 0.6"

The QFP socket accepts packages with the dimensions listed below:

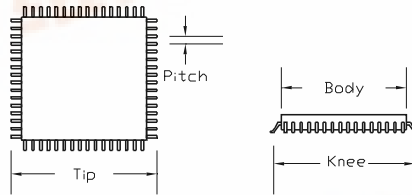

Body	Knee	Tip	Pitch
10.0 mm typical	11.0 mm typical 11.6 maximum	12 mm typical 13.2 maximum	0.8 mm

## Adapter Dimensions

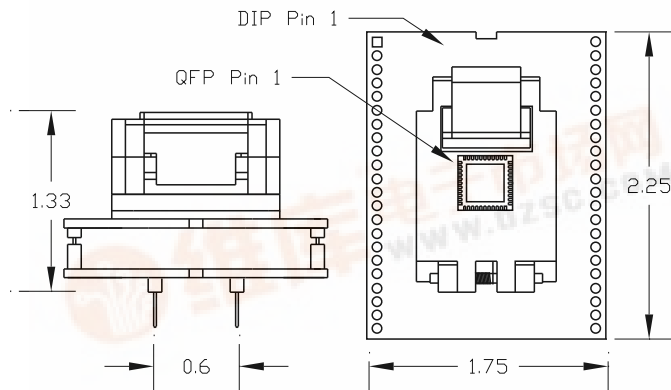

## Adapter Construction

The adapter is made up of 3 sub-assemblies. They assemble via connectors making the adapter modular. This way the sub-assemblies can be replaced when they wear out.

When disassembling the adapter take care not to bend the pins. When reassembling the adapter note the pin 1 indicators to align the parts correctly.

### Test Socket

Lidded QFP test socket:

Enplas Part #: FPQ-44-0.8-06T

LSC Part #: 44QF-06T

### 44QFP-6T

Accepts the test socket and connects to the bottom board.

### MACH210 BASE

Performs the wiring shown in the Adapter Wiring section.

## Adapter Wiring

The following chart shows the connections from the QFP device to the adapter's DIP plug.

DEVICE	SIGNAL	PLUG
39	GND	14
40	I/O 0	12
41	10K	14
42	I/O 2	13
43	10K	14
44	I/O 4	18
1	10K	14
2	I/O 6	19
3	I/O 7	20
4	VPP	2
5	MD0	3
6	GND	14
7	CLK0	1
8	I/O 8	6
9	I/O 9	7
10	10K	14
11	I/O 11	8
12	10K	14
13	I/O 13	9
14	10K	14
15	I/O 15	10
16	VCC	28

DEVICE	SIGNAL	PLUG
17	GND	14
18	I/O 16	11
19	10K	14
20	I/O 18	15
21	10K	14
22	I/O 20	16
23	10K	14
24	I/O 22	17
25	I/O 23	21
26	MD1	4
27	MD2	5
28	GND	14
29	CLK1	27
30	I/O 24	22
31	I/O 25	23
32	10K	14
33	I/O 27	24
34	10K	14
35	I/O 29	25
36	10K	14
37	I/O 31	26
38	VCC	28

VCC to GND has a 0.1uf capacitor.