



S-Band Phase Shifter

2.3-4.1 GHz

MAPCGM0003

Preliminary Information

Features

- ◆ 2.3 to 4.1 GHz Operation
- ◆ 6 Bit Phase Shifter
- ◆ 360° Coverage, LSB = 5.6°
- ◆ TTL Control Inputs
- ◆ Self-Aligned MSAG® MESFET Process
- ◆ 6mm, 28 Lead, FQFP-N Package

Primary Applications

- ◆ Satellite Communication
- ◆ Phased Array Radar

Description

The MAPCGM0003 is a 6-bit Phase Shifter with Parallel TTL Input Control and is packaged in a micro lead package (MLP). This product is fully matched to 50 ohms on both the input and output. This part has 360° of phase coverage in 5.6° increments.

Each device is 100% RF tested on wafer to ensure performance compliance. The part is fabricated using M/A-COM's repeatable, high performance and highly reliable GaAs Multifunction Self-Aligned Gate (MSAG®) MESFET Process.

2.3-4.1 GHz GaAs MMIC Phase Shifter

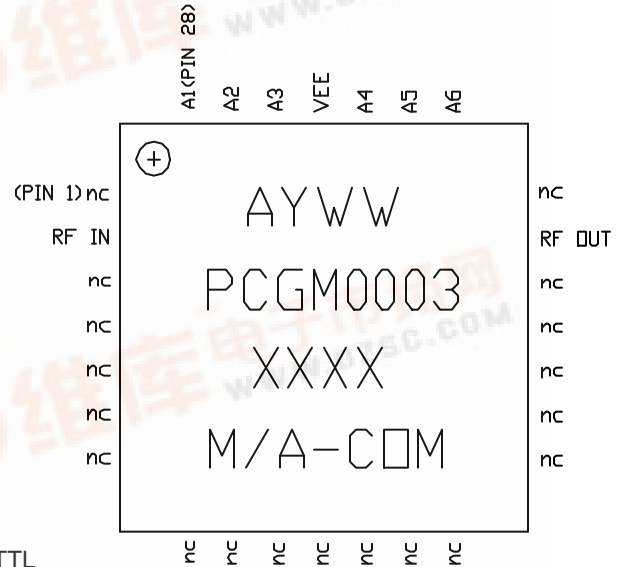

Pin Number	Designation
2	RF IN
20	RF OUT
22	A6 (180°)
23	A5 (90°)
24	A4 (45°)
25	V _{EE}
26	A3 (22.5°)
27	A2 (11.25°)
28	A1 (5.6°)
1,3-19,21	No connection

Maximum Operating Conditions ¹

Parameter	Symbol	Absolute Maximum	Units
Input Power	P _{IN}	30	dBm
Source Supply Voltage	V _{EE}	-4.8	V
Junction Temperature	T _J	180	°C
Storage Temperature	T _{STG}	-55 to +150	°C

¹ Operation outside of these ranges may reduce product reliability. Operation at other than the typical values may result in performance outside the guaranteed limits.



S Band Phase Shifter

MAPCGM0003

Recommended Operating Conditions

Characteristic	Symbol	Min	Typ	Max	Unit
Digital Supply Voltage	VEE	-5.2	-5.0	-4.8	V
Control Voltage	A1 thru A6				
Logic High		3	5	5	V
Logic Low		0	0	0.4	V
Junction Temperature	T _J			150	°C

Electrical Characteristics: T_B = 25°C, Z₀ = 50Ω, V_{EE} = -5V

Parameter	Symbol	Typical	Units
Bandwidth	f	2.3-4.1	GHz
Insertion Loss	IL	6	dB
Input VSWR (At Reference)	VSWR	1.5:1	
Output VSWR (At Reference)	VSWR	1.2:1	
RMS Phase Error	RMS	6	°
RMS Phase Error — Calibrated	RMS	3	°
Phase Range	??	360	°
Gain Variation over all Phase Shifter settings	?G	< 3	dB
Digital Supply Current	I _{EE}	< 10	mA
Input Third Order Intercept	ITOI	36	dBm
Input 1-dB Compression Point	P _{1dB}	23	dBm

Operating Instructions

This device is static sensitive. Please handle with care. To operate the device, follow these steps.

1. Apply V_{EE} = -5 V.
2. Apply Logic Voltages to control circuit as listed in Recommended Operating Conditions Table.
3. Power Down. Set V_{EE} = 0.

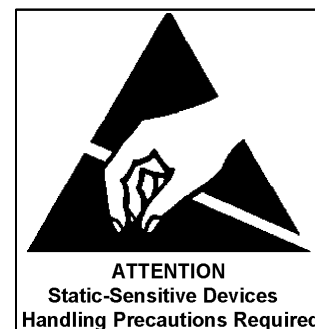

Specifications subject to change without notice.

Email: macom_adbu_ics@tycoelectronics.com

■ North America: Tel. (800) 366-2266

tyco / Electronics

MACOM

S Band Phase Shifter

MAPCGM0003

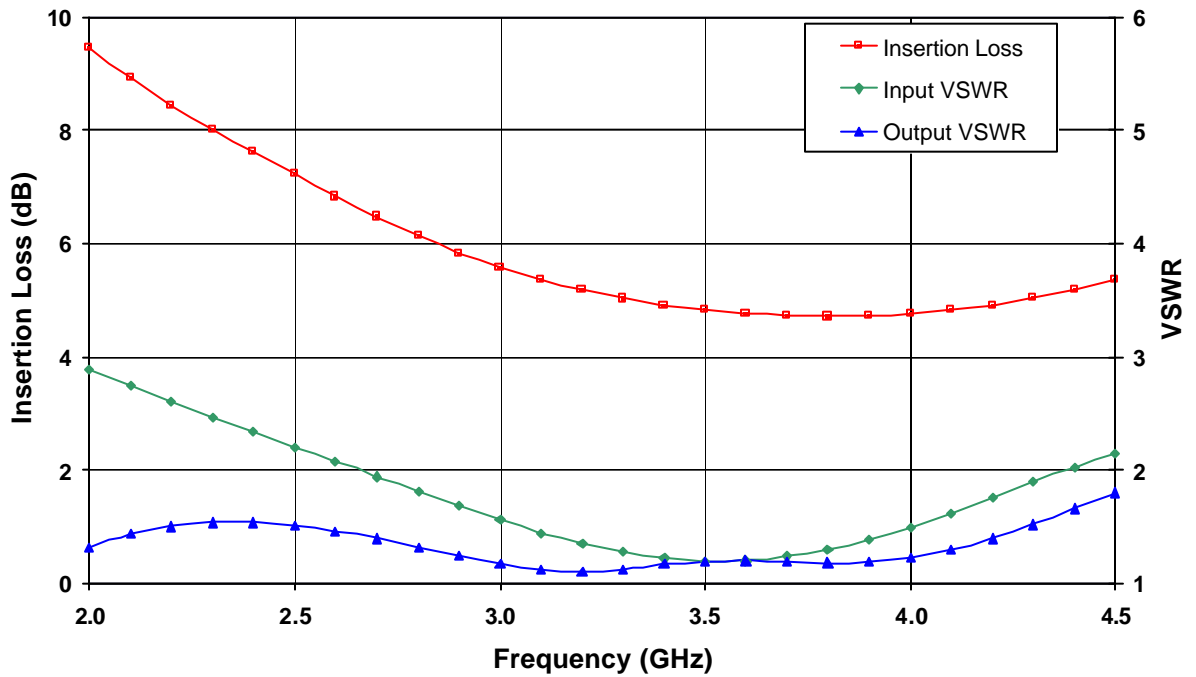

Figure 1. Reference State Insertion Loss, Input and Output VSWR vs. Frequency

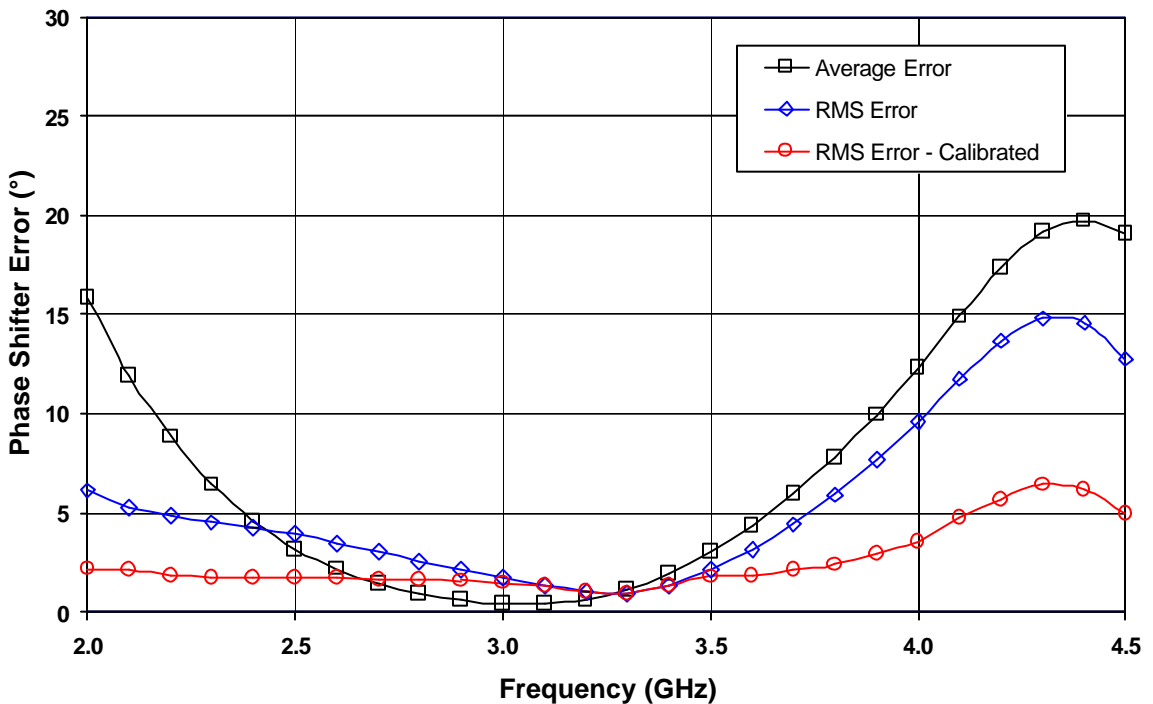

Figure 2. Phase Shifter Figures of Merit: Average Error vs. Reference State, RMS Error and Calibrated RMS Error Over All States

Specifications subject to change without notice.

Email: macom_adbu_ics@tycoelectronics.com

North America: Tel. (800) 366-2266



S Band Phase Shifter

MAPCGM0003

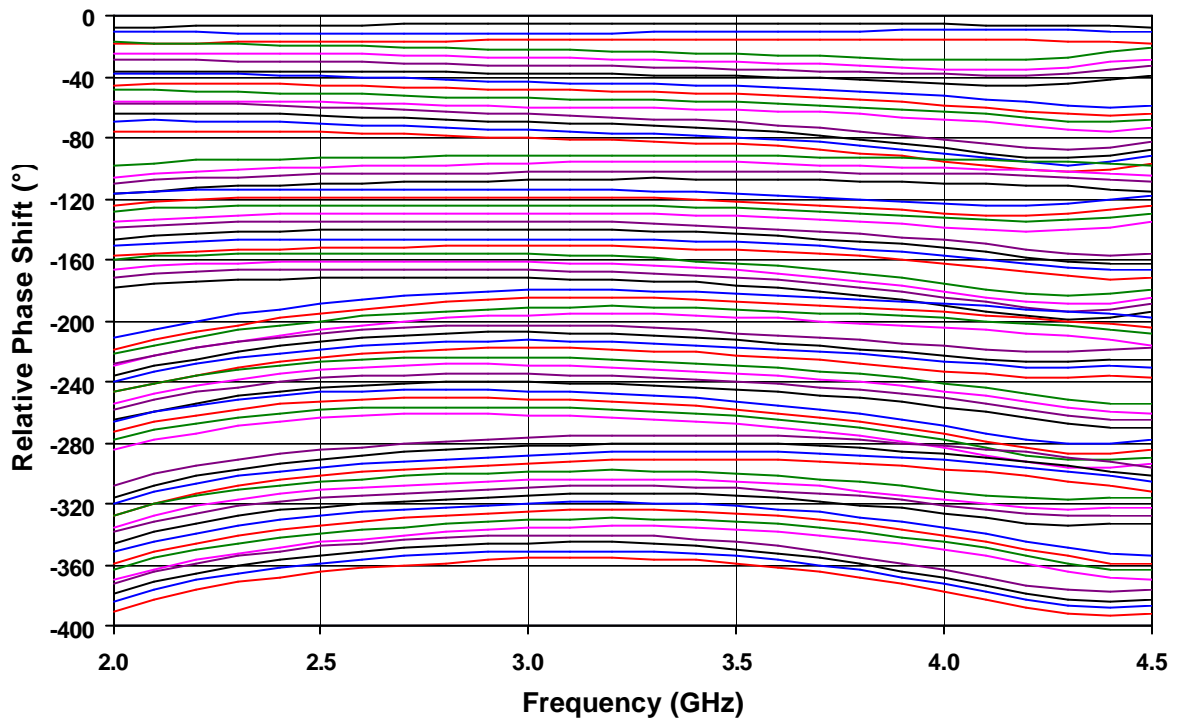

Figure 3. Relative Phase Shift vs. Phase Shifter State

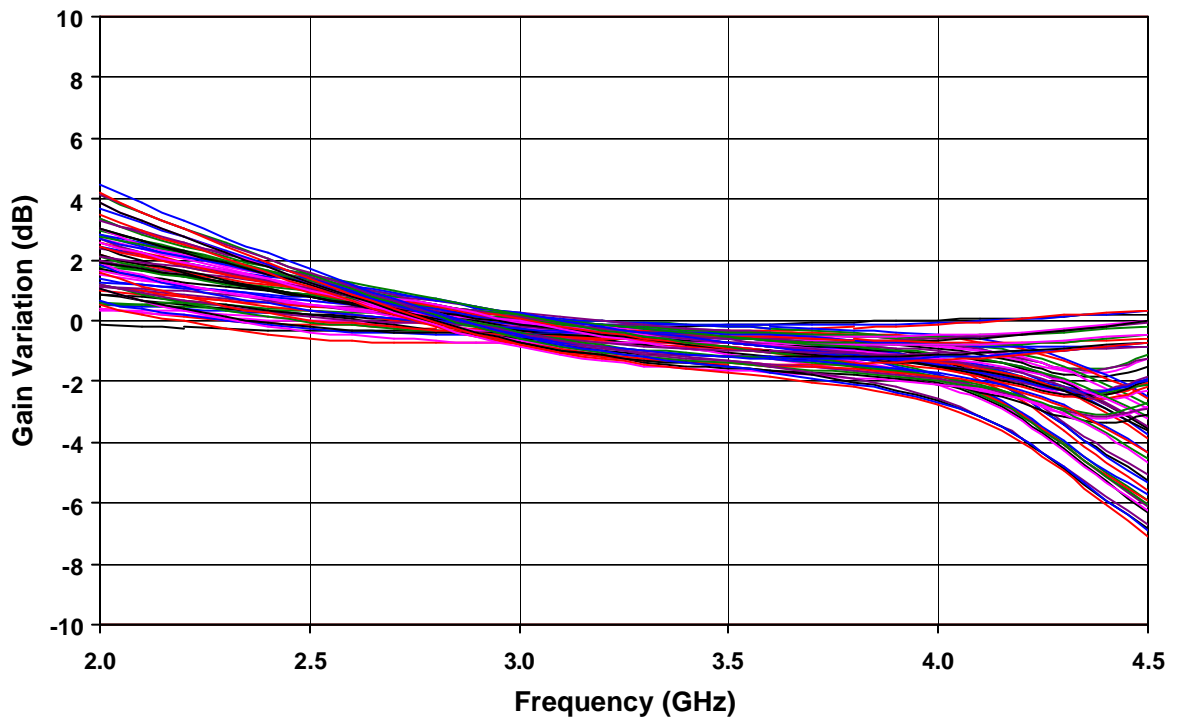

Figure 4. Relative Gain Change vs. Phase Shifter State

Specifications subject to change without notice.

Email: macom_adbu_ics@tycoelectronics.com

North America: Tel. (800) 366-2266



S Band Phase Shifter MAPCGM0003

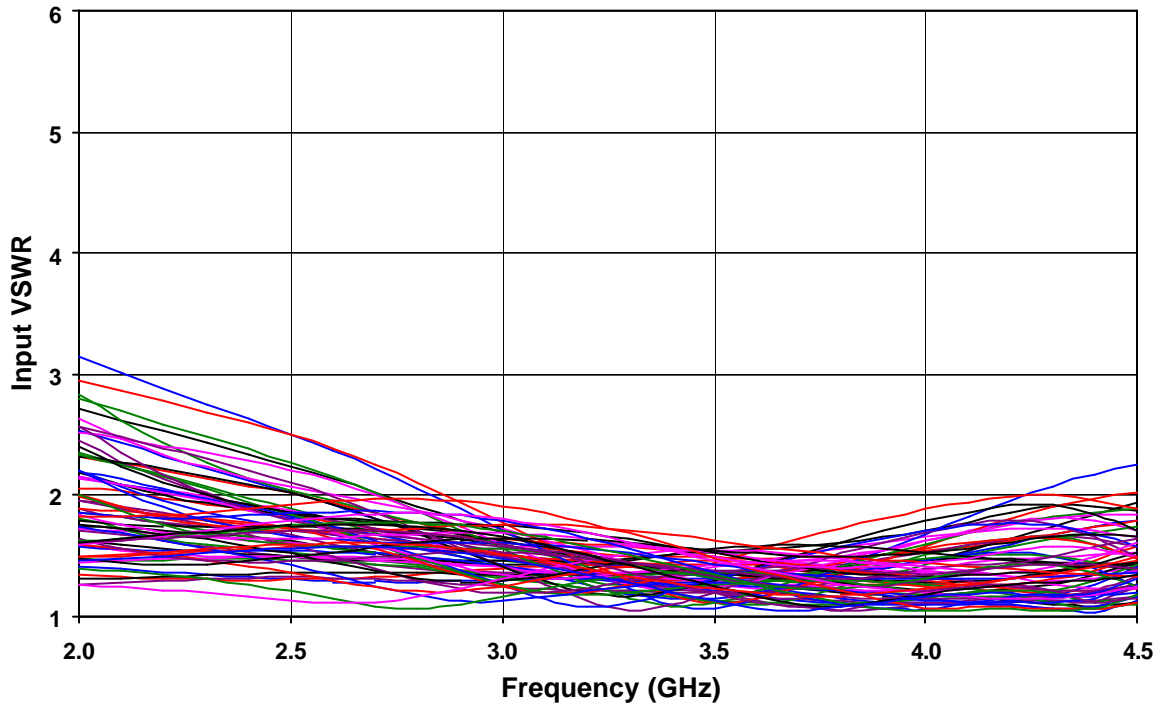

Figure 5. Input VSWR vs. Phase Shifter State

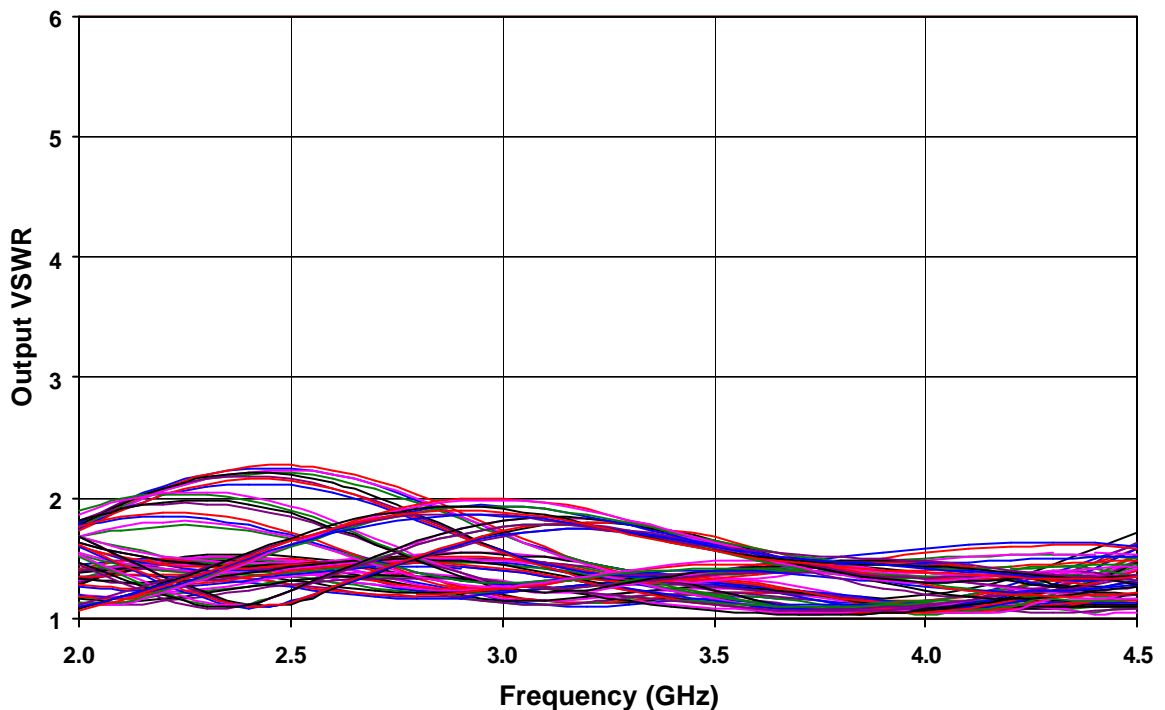

Figure 6. Output VSWR vs. Phase Shifter State

Specifications subject to change without notice.

Email: macom_adbu_ics@tycoelectronics.com

North America: Tel. (800) 366-2266



S Band Phase Shifter

MAPCGM0003

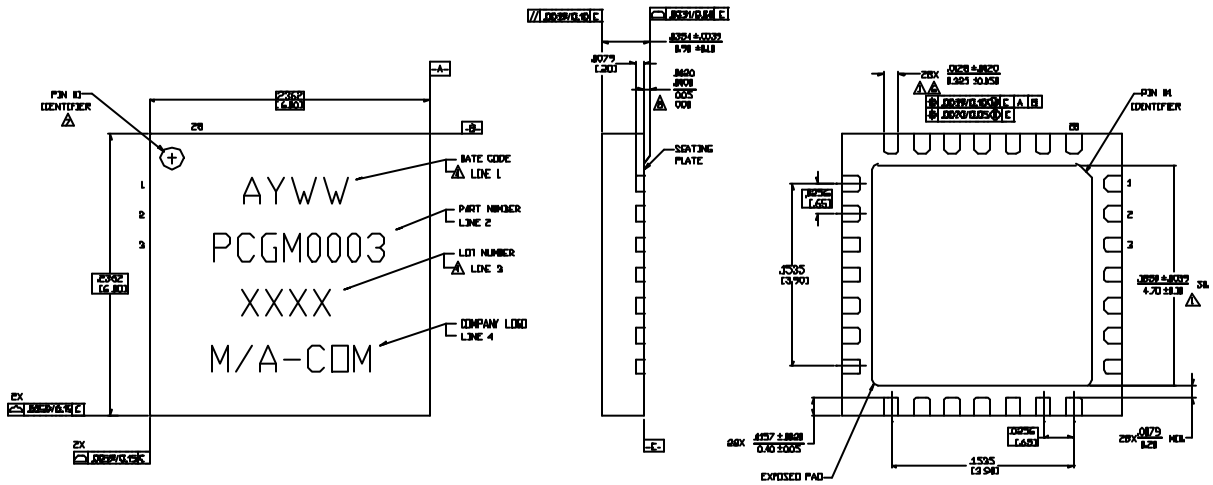

Figure 7. FQFP-N, 6mm, 28 Lead Package Drawing

Reference JEDEC M0-220 (see <http://www.jedec.org>), VAR. VJJC-3 (Issue E) for additional dimensional and tolerance information.

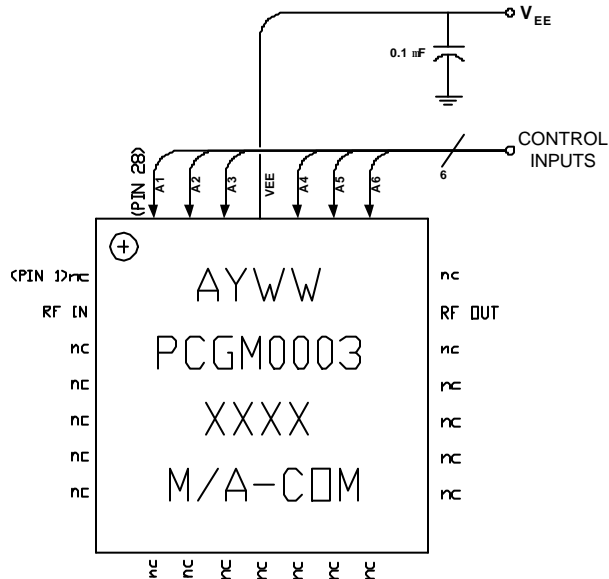

Figure 8. Recommended Bias Configuration

Refer to M/A-COM Application Note **Surface Mounting Instructions for FQFP-N Packages #S2083*** for assembly guidelines.

Application Notes can be found by going to the Site Search Page on M/A-COM's web page (<http://www.macom.com/search/search.jsp>) and searching for the required Application Note.

Specifications subject to change without notice.

Email: macom_adbu_ics@tycoelectronics.com

North America: Tel. (800) 366-2266



S Band Phase Shifter

MAPCGM0003

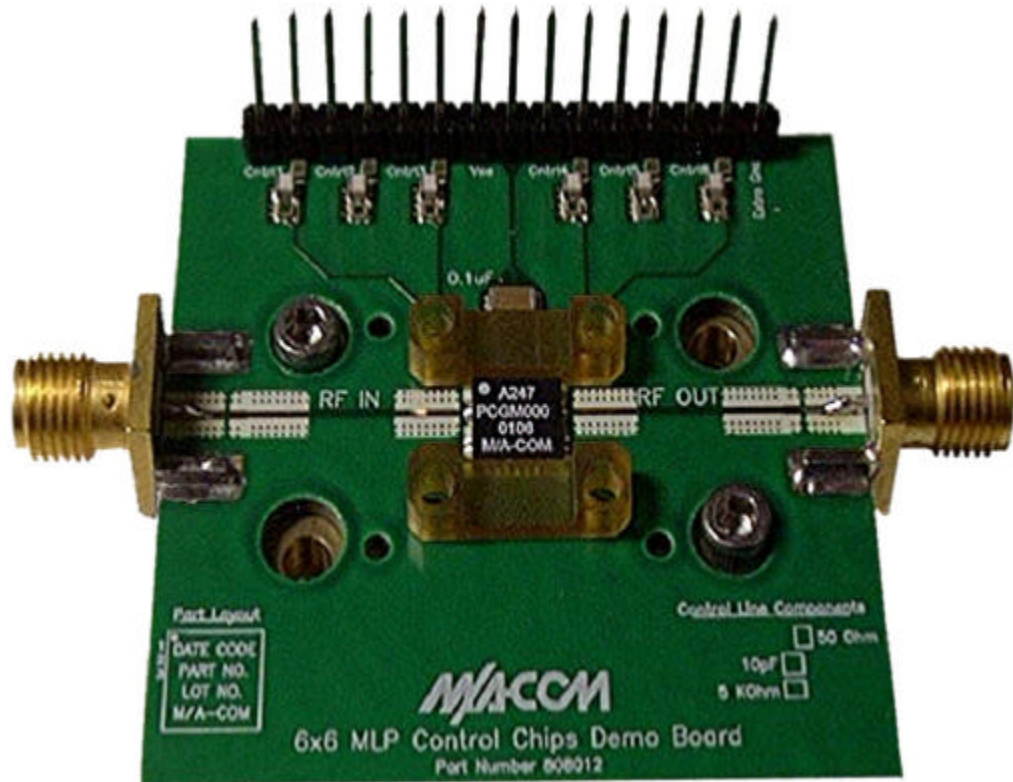

Figure 9. Demonstration Board (available upon request).

Specifications subject to change without notice.

Email: macom_adbu_ics@tycoelectronics.com

■ North America: Tel. (800) 366-2266

tyco / Electronics

MACOM