

DS04-21301-5E

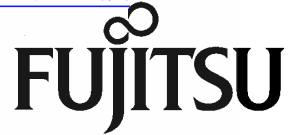

DATA SHEET

MB1504/MB1504H/MB1504L

ASSP SERIAL INPUT PLL FREQUENCY SYNTHESIZER

SERIAL INPUT PLL FREQUENCY SYNTHESIZER WITH 520MHz PRESCALER

The Fujitsu MB1504/MB1504H/MB1504L, utilizing BI-CMOS technology, is a single chip serial input PLL frequency synthesizer with pulse-swallow function.

The MB1504 series contains a 520MHz two modulus prescaler that can select either 32/33 or 64/65 divide ratio; control signal generator; 16-bit shift register; 15-bit latch; programmable reference divider (binary 14-bit programmable reference counter); 1-bit switch counter; phase comparator with phase inverse function; charge pump; crystal oscillator; 19-bit shift register; 18-bit latch; and a programmable divider (binary 7-bit swallow counter and binary 11-bit programmable counter).

The MB1504 operates from a low supply voltage (3V typ) and consumes low power (30mW at 520MHz).

MB1504 Product Line

	V _P Voltage	V _{OOP} Voltage	Lock up Time	D _O Output Width	High-level Output Current	Low-level Output Current
MB1504	8V max	8.5V max	Middle speed	Middle	Middle	Middle
MB1504H	10V max	10.0V max	High speed	Low	High	Low
MB1504L	8V max	8.5V max	Low speed	High	Low	High

FEATURES

- High operating frequency: $f_{IN\ MAX}=520MHz$ ($V_{IN\ MIN}=0.20V_{P-P}$)
- On-chip prescaler
- Low power supply voltage: 2.7V to 5.5V (3.0V typ)
- Low power supply consumption: 30mW (3.0V, 520MHz operation)
- Serial input 18-bit programmable divider consisting of:
 - Binary 7-bit swallow counter (Divide ratio: 0 to 127)
 - Binary 11-bit programmable counter (Divide ratio: 16 to 2047)
- Serial input 15-bit programmable reference divider consisting of:
 - Binary 14-bit programmable reference counter (Divide ratio: 8 to 16383)
 - 1-bit switch counter (SW) Sets divide ratio of prescaler
- 2 types of phase detector output
 - On-chip charge pump (Bipolar type)
 - Output for external charge pump
- Wide operating temperature: $T_A=-40^{\circ}C$ to $+85^{\circ}C$

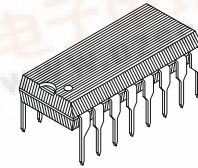

PLASTIC PACKAGE
DIP-16P-M04

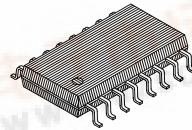

PLASTIC PACKAGE
FPT-16P-M06

This device contains circuitry to protect the inputs against damage due to high static voltages or electric fields. However, it is advised that normal precautions be taken to avoid application of any voltage higher than maximum rated voltages to this high impedance circuit.



MB1504
MB1504H
MB1504L

PIN ASSIGNMENT

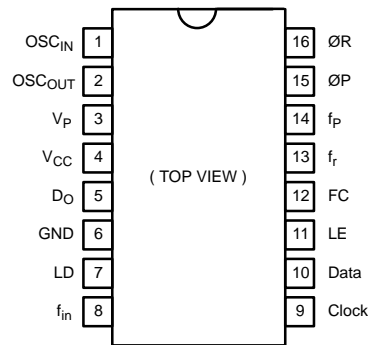

ABSOLUTE MAXIMUM RATINGS (see NOTE)

Rating	Symbol	Condition	Value	Unit
Power Supply Voltage	V _{CC}	—	-0.5 to +7.0	V
	V _{PH}	MB1504H	V _{CC} to 12.0	V
	V _P , V _{PL}	MB1504/1504L	V _{CC} to 10.0	V
Output Voltage	V _{OUT}	—	-0.5 to V _{CC} +0.5	V
Open-drain Output	V _{OOPH}	MB1504H	-0.5 to 11.0	V
	V _{OOP} , V _{OOPL}	MB1504/1504L	-0.5 to 9.0	V
Output Current	I _{OUT}	—	+10	mA
Storage Temperature	T _{STG}	—	-55 to +125	°C

NOTE: Permanent device damage may occur if the above **Absolute Maximum Ratings** are exceeded. Functional operation should be restricted to the conditions as detailed in the operational sections of this data sheet. Exposure to absolute maximum rating conditions for extended periods may affect device reliability.

MB1504/MB1504H/MB1504L BLOCK DIAGRAM

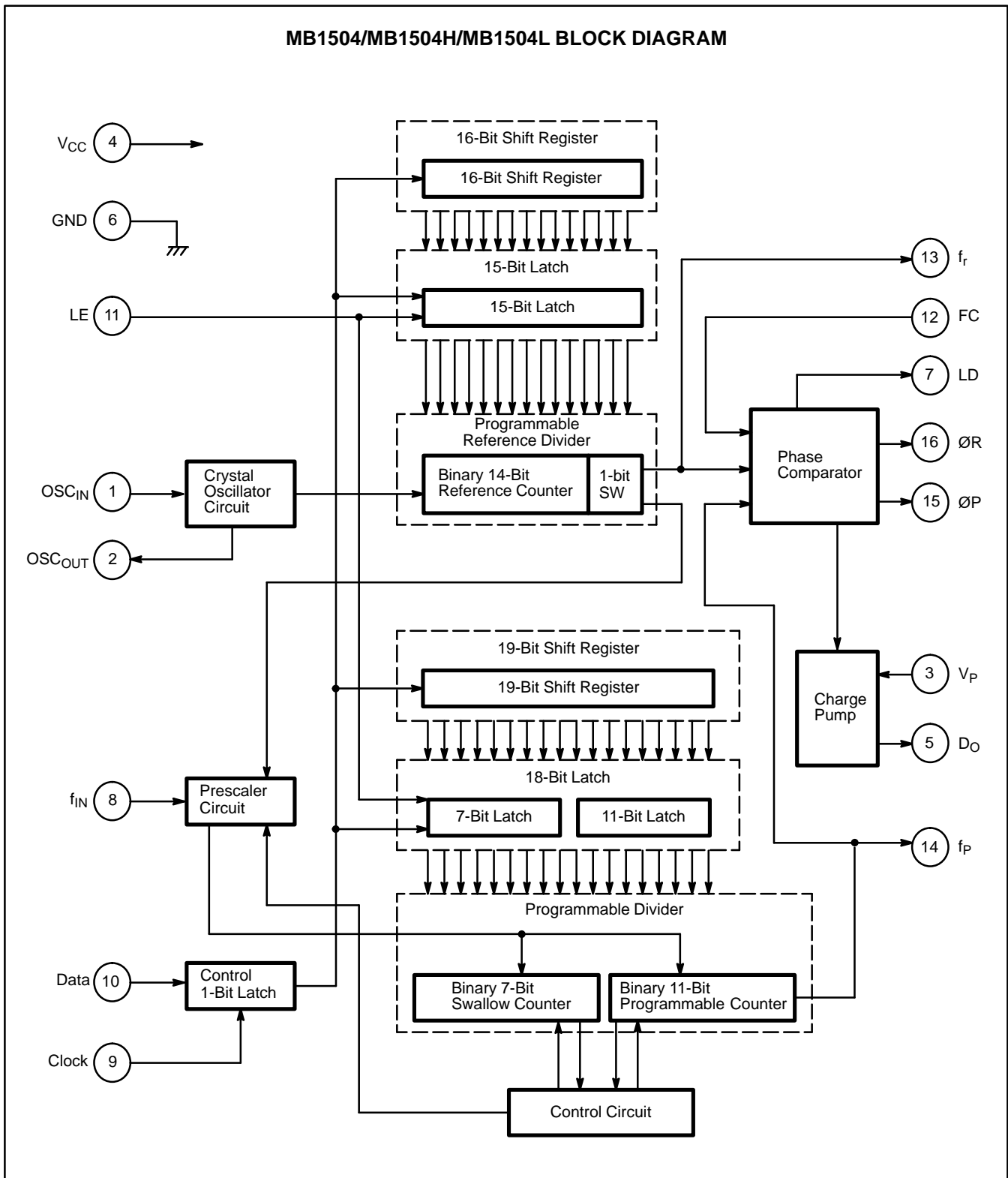

MB1504
 MB1504H
 MB1504L

PIN DESCRIPTIONS

Pin No.	Pin Name	I/O	Descriptions
1 2	OSC _{IN} OSC _{OUT}	I O	Oscillator input Oscillator output A crystal is placed between OSC _{IN} and OSC _{OUT} .
3	V _P	—	Power supply input for charge pump
4	V _{CC}	—	Power supply voltage input
5	D _O	O	Charge pump output The phase characteristics can be inversed depending upon the FC input.
6	GND	—	Ground
7	LD	O	Phase comparator output This pin outputs high when the phase is locked. While the phase difference of f _r and f _p exists, the output level goes low.
8	f _{IN}	I	Prescaler input The connection with an external VCO should be an AC connection.
9	Clock	I	Clock input for 19-bit shift register and 16-bit shift register Each rising edge of the clock shifts one bit of data into the shift registers.
10	Data	I	Serial data of binary code input The last bit of the data is a control bit. The last data bit specifies which latch is activated. When the last bit is high level and LE is high-level, data is transferred to the 15-bit latch. When the last bit is low level and LE is high level, data is transferred to the 18-bit latch.
11	LE	I	Load enable input (with internal pull up resistor) When LE is high level (or open), data stored in the shift register is transferred to the latch depending on the control data.
12	FC	O	Phase selecting input of phase comparator (with internal pull up resistor) When FC is low level, the charge pump and phase detector characteristics can be inversed.
13	f _r	O	Monitor pin of phase comparator input It is the same as the programmable reference divider output.
14	f _p	O	Monitor pin of phase comparator input It is the same as the programmable divider output.
15 16	ØP ØR	O O	Outputs for external charge pump The phase characteristics can be inversed depending on the FC input. The ØP pin is an N-channel open-drain output.

FUNCTIONAL DESCRIPTIONS

SERIAL DATA INPUT

Serial data input is input using the Data pin, Clock pin and LE pin. The 15-bit programmable reference divider and 18-bit programmable divider are controlled, respectively.

On rising edge of the clock, one bit of the data shifts into the internal shift registers.

When load enable (LE) is high level (or open), data stored in the shift registers is transferred to the 15-bit latch or 18-bit latch depending upon the control bit level.

Control data "H" : Data is transferred into the 15-bit latch.

Control data "L" : Data is transferred into the 18-bit latch.

PROGRAMMABLE REFERENCE DIVIDER

The programmable reference divider consists of a 16-bit shift register, 15-bit latch and 14-bit reference counter. Serial 16-bit data format is shown below.

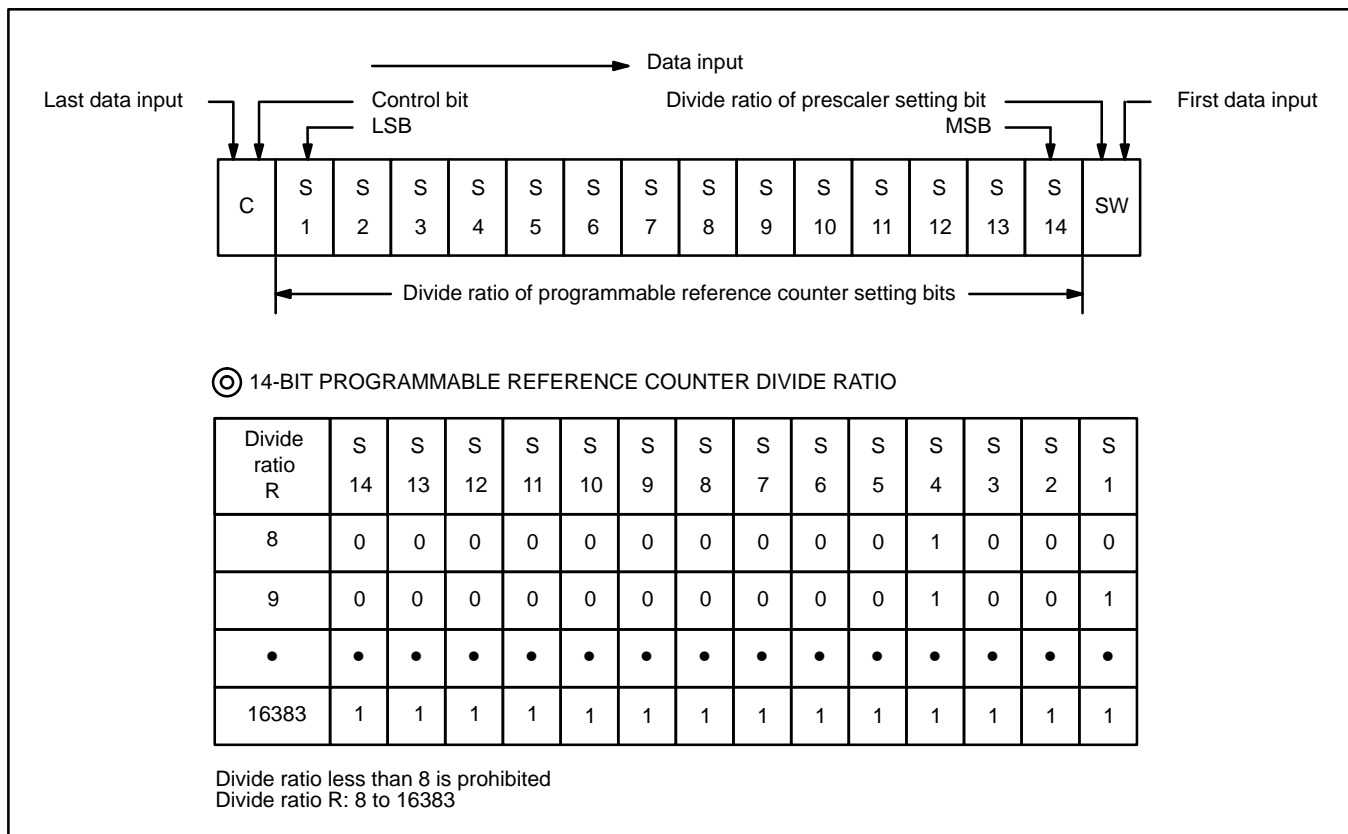

SW: Divide ratio of prescaler setting bit

SW="H": 32

SW="L": 64

S₁ to S₁₄: Divide ratio of programmable reference counter setting bits (8 to 16383)

C: Control bit (control bit is set to high)

MB1504
MB1504H
MB1504L

FUNCTIONAL DESCRIPTIONS

PROGRAMMABLE DIVIDER

The programmable divider consists of a 19-bit shift register, 18-bit latch, 7-bit swallow counter and 11-bit programmable counter.
 Serial 19-bit data format is shown below.

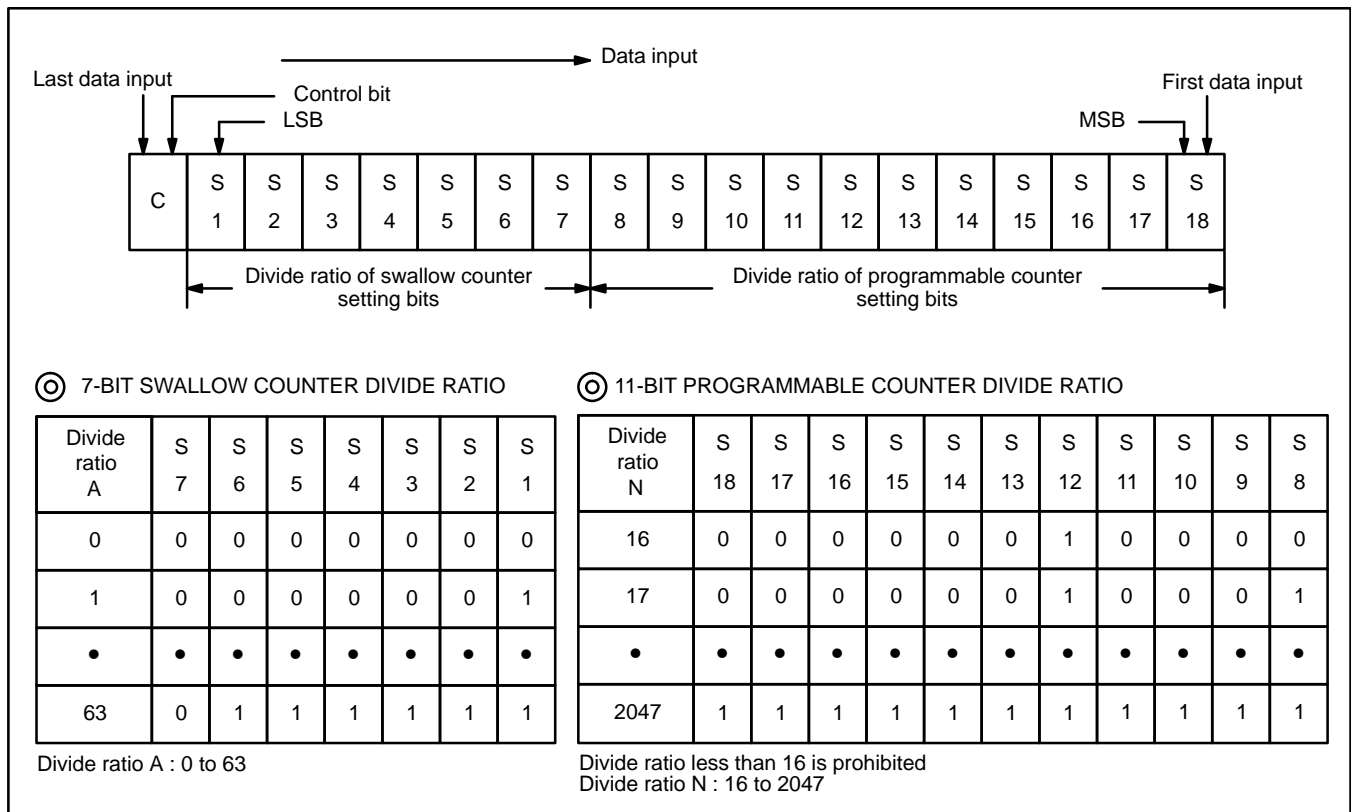

S₈ to S₁₈ : Divide ratio of programmable counter setting bits (16 to 2047)
 S₁ to S₇ : Divide ratio of swallow counter setting bits (0 to 127)
 C: Control bit (control bit is set to low)
 Data is input from the MSB.

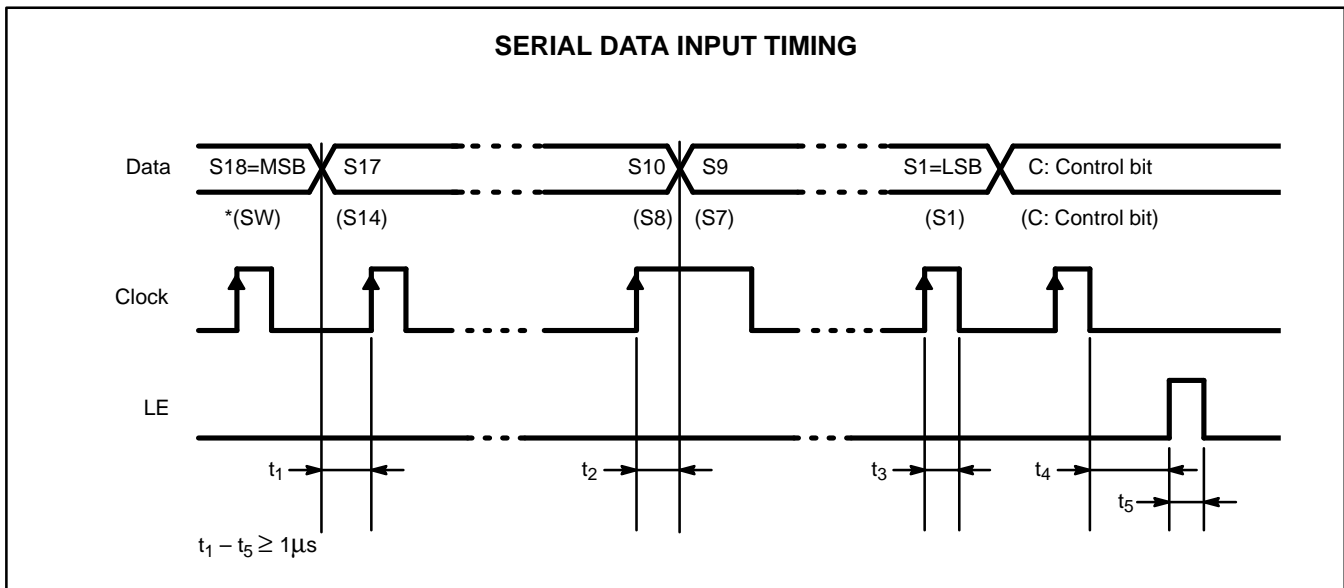

On the rising edge of the clock, one bit of the data shifts into the shift registers.
Data in () is used for setting the divide ratio of the programmable reference divider.

PHASE CHARACTERISTICS

The FC pin (pin 12) is provided to inverse the phase comparator characteristics. The characteristics of the internal charge pump output (D_O), and phase detector outputs ($\emptyset R$, $\emptyset P$) can be inverted depending upon the FC input data. Outputs are shown below.

	FC=H (or open)			FC=L		
	D_O	$\emptyset R$	$\emptyset P$	D_O	$\emptyset R$	$\emptyset P$
$f_r > f_p$	H	L	L	L	H	Z
$f_r < f_p$	L	H	Z	H	L	L
$f_r = f_p$	Z	L	Z	Z	L	Z

Note: Z=(High impedance)

Depending upon VCO characteristics, FC pin should be set accordingly:
When VCO characteristics are like ①, FC should be set high or open circuit;
When VCO characteristics are like ②, FC should be set Low.

VCO CHARACTERISTICS

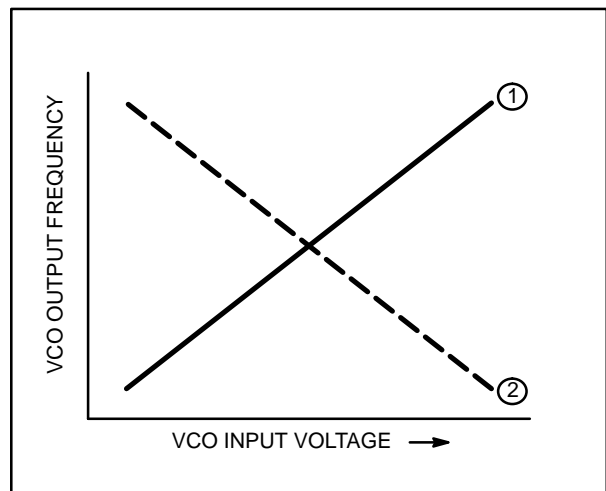

MB1504
MB1504H
MB1504L

RECOMMENDED OPERATING CONDITIONS

Parameter	Symbol		Value			Unit
			Min	Typ	Max	
Power Supply Voltage	V_{CC}	—	2.7	3.0	5.5	V
	V_{PH}	MB1504H	V_{CC}	—	10.0	V
	V_P, V_{PL}	MB1504 MB1504L	V_{CC}	—	8.5	
Open-drain Output	V_{OOPH}	MB1504H	V_{CC}	—	10.0	V
	V_{OOP}, V_{OOPL}	MB1504 MB1504L	V_{CC}	—	8.5	
Input Voltage	V_{IN}	—	GND	—	V_{CC}	V
Operating Temperature	T_A	—	-40	—	+85	°C

HANDLING PRECAUTIONS

- This device should be transported and stored in anti-static containers.
- This is a static-sensitive device; take proper anti-ESD precautions. Ensure that personnel and equipment are properly grounded. Cover workbenches with grounded conductive mats.
- Always turn the power supply off before inserting or removing the device from its socket.
- Protect leads with a conductive sheet when handling or transporting PC boards with devices.

ELECTRICAL CHARACTERISTICS

($V_{CC}=2.7$ to $5.5V$, $T_A=-40$ to $+85^{\circ}C$)

Parameter	Pin Name	Symbol	Condition	Value			Unit	
				Min	Typ	Max		
Power Supply Current	V_{CC}	I_{CC}	*1	—	10	16	mA	
Operating Frequency	f_{IN}	f_{IN}	*2	10	—	520	MHz	
	OSC_{IN}	f_{OSC}		—	12	20	MHz	
Input Sensitivity	f_{IN}	Pf_{IN1}	$V_{CC}=2.7$ to $4.0V$	-10	—	6	dBm	
		Pf_{IN2}	$V_{CC}=4.0$ to $5.5V$	-4	—	6	dBm	
	OSC_{IN}	V_{IN}	—	0.5	—	—	V_{P-P}	
High-level Input Voltage	Except f_{IN} and OSC_{IN}	V_{IH}	—	$0.7 \times V_{CC}$	—	—	V	
Low-level Input Voltage		V_{IL}	—	—	—	$0.3 \times V_{CC}$	V	
High-level Input Current	Data, Clock	I_{IH}	—	—	1.0	—	μA	
Low-level Input Current		I_{IL}	—	—	-1.0	—	μA	
Input Current	OSC_{IN}	I_{IN}	—	—	± 50	—	μA	
	LE, FC	I_{LE}	—	—	-60	—	μA	
High-level Output Voltage	Except D_O and OSC_{OUT}	V_{OH}	$V_{CC}=3.0V$	2.4	—	—	V	
Low-level Output Voltage		V_{OL}		—	—	0.4	V	
N-channel Open-drain Cutoff Current	$\emptyset P$	I_{OFF}	$V_{CC} \leq V_P \leq 8V$	—	—	1.1	μA	
High-level Output Current	Except D_O and OSC_{OUT}	I_{OH}	—	-1.0	—	—	mA	
Low-level Output Current		I_{OL}	—	1.0	—	—	mA	
High-level Output Current	D_O	I_{DOHH}	MB1504H	$V_{CC}=3V$ $V_P=12V$, $T_A=+25^{\circ}C$	-2.2	-4.5	—	mA
		I_{DOH}	MB1504	$V_{CC}=3V$ $V_P=6V$, $T_A=+25^{\circ}C$	-0.5	-2.0	—	mA
		I_{DOHL}	MB1504L		-0.5	-1.1	-2.2	mA
Low-level Output Current		I_{DOLH}	MB1504H	$V_{CC}=3V$ $V_P=12V$, $T_A=+25^{\circ}C$	2.2	6.0	—	mA
		I_{DOL}	MB1504	$V_{CC}=3V$ $V_P=6V$, $T_A=+25^{\circ}C$	1.5	6.0	—	mA
		I_{DOLL}	MB1504L		4.5	12.0	—	mA
Leakage Current	D_O , $\emptyset P$	I_{DOZ}	$V_{CC}=3V$ $V_P=12V$, $T_A=+25^{\circ}C$	—	—	1.0	μA	

Note: *1 $V_{CC}=3.0V$, $f_{IN}=520MHz$, $f_{OSC}=12MHz$ crystal.
Inputs are grounded except f_{IN} , and outputs are open.
*2 Input coupling capacitor 1000pF is connected.

MB1504
 MB1504H
 MB1504L

TYPICAL CHARACTERISTICS CURVES

CHARGE PUMP CHARACTERISTICS

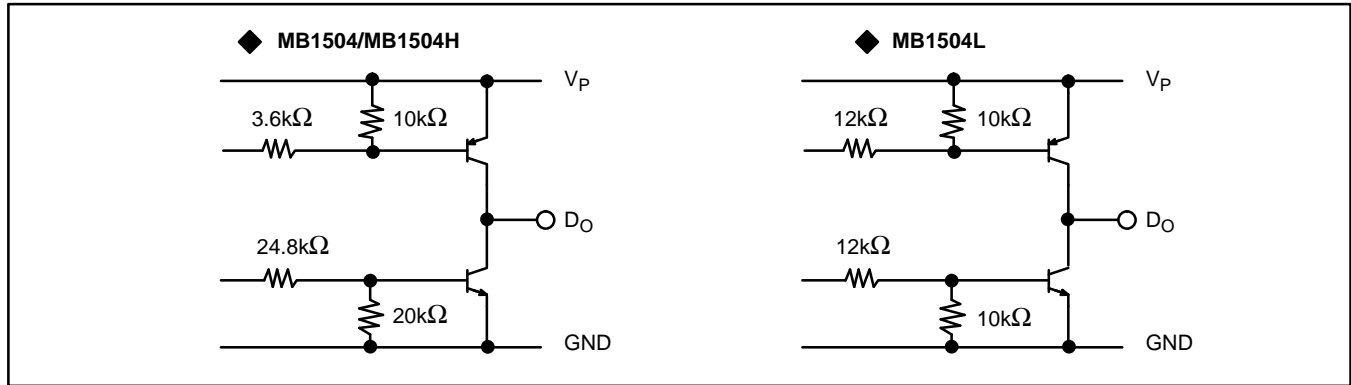

LOCK UP TIME MEASUREMENT

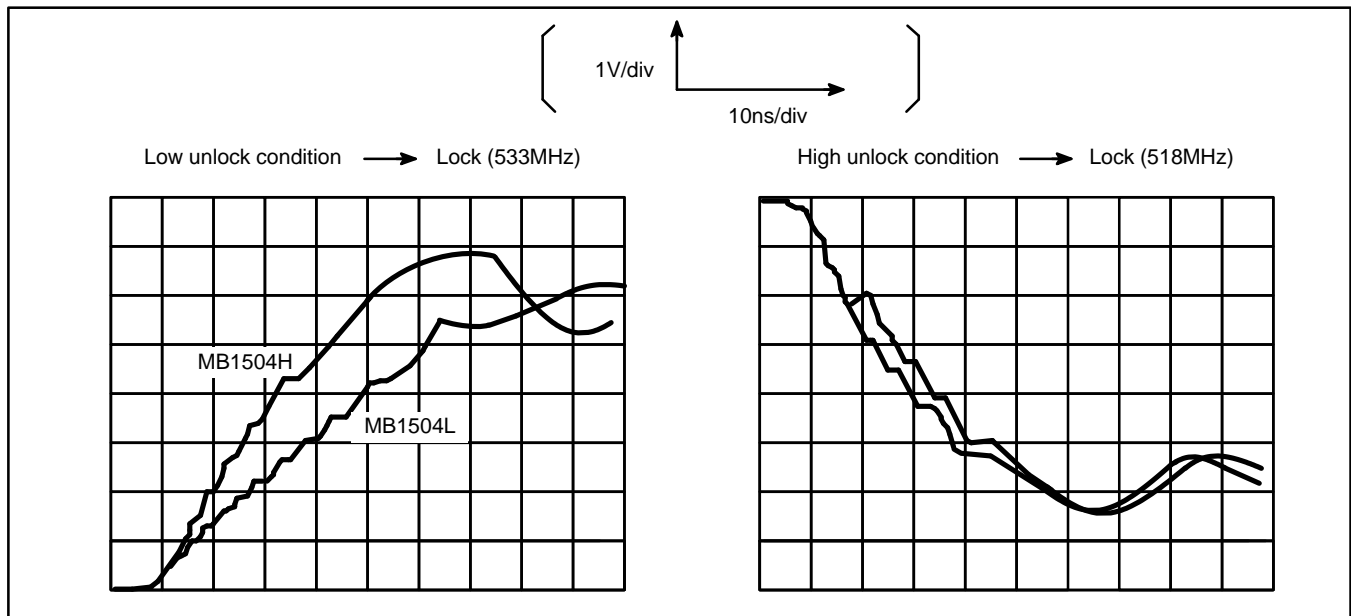

DO PIN OUTPUT CURRENT CURVES (TYPICAL)

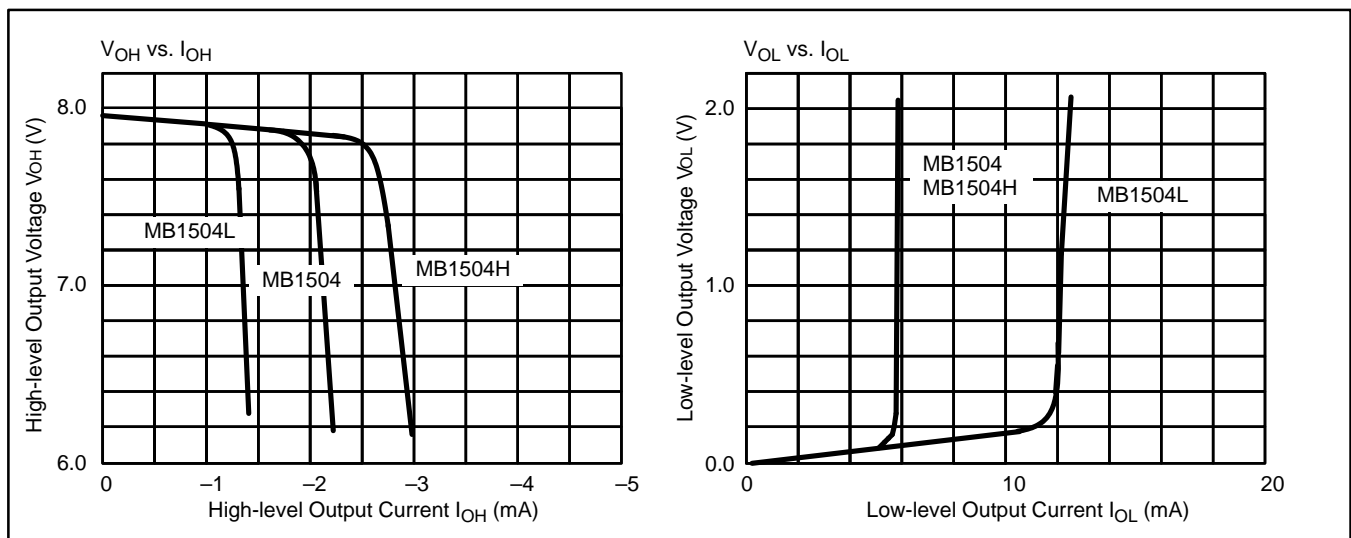

D_O PIN OUTPUT WAVEFORM AT LOCK CONDITION

Output Waveform

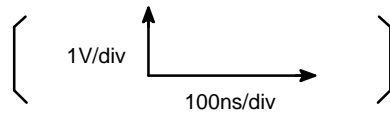

MB1504

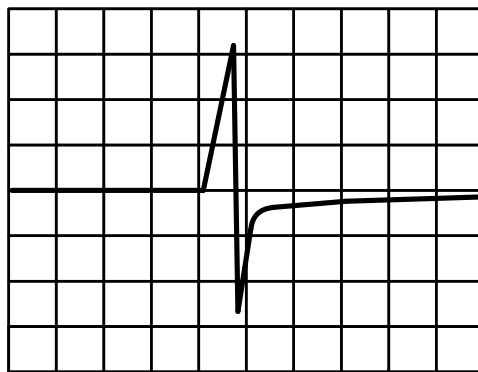

MB1504H

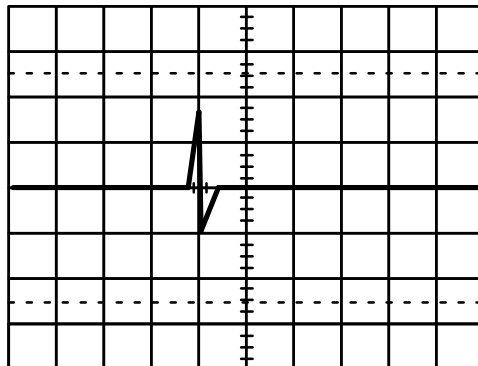

MB1504L

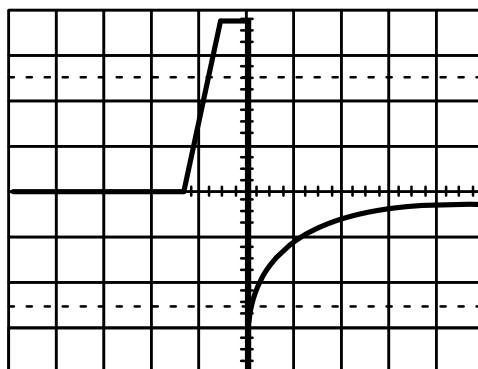

MB1504
MB1504H
MB1504L

PHASE CHARACTERISTICS (Δf vs. D_O OUTPUT ENERGY)

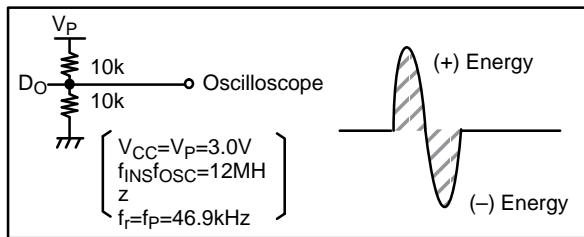
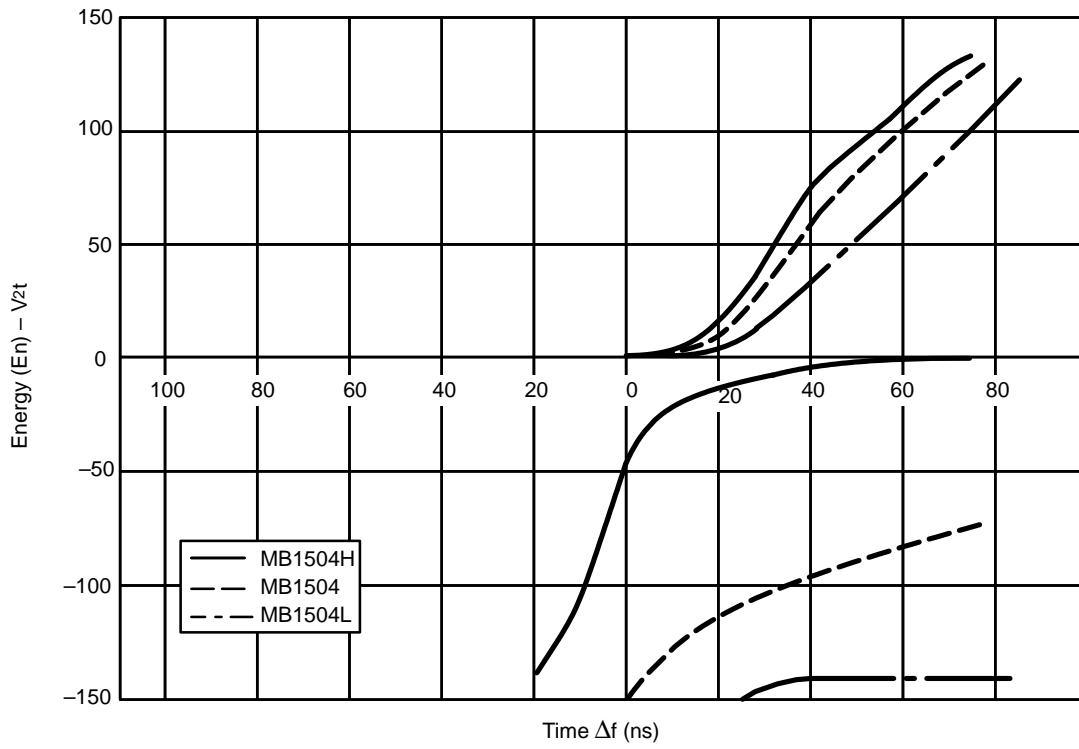

INPUT SENSITIVITY

Input Sensitivity vs. Input Frequency (Supply Voltage Dependence)

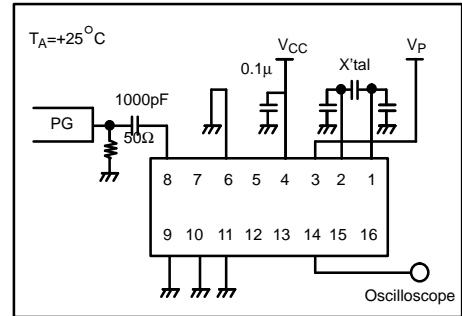
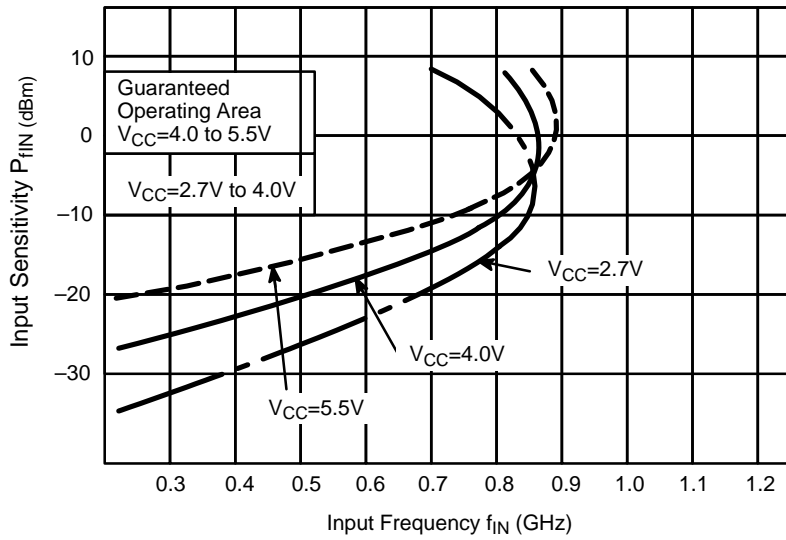

Input Sensitivity vs. Input Frequency (Temperature Dependence)

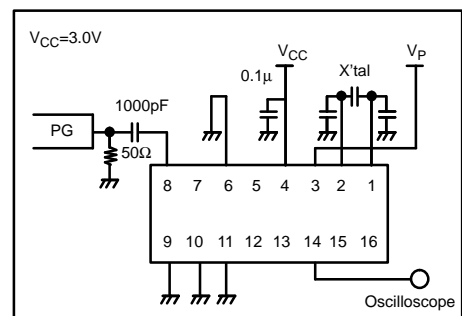
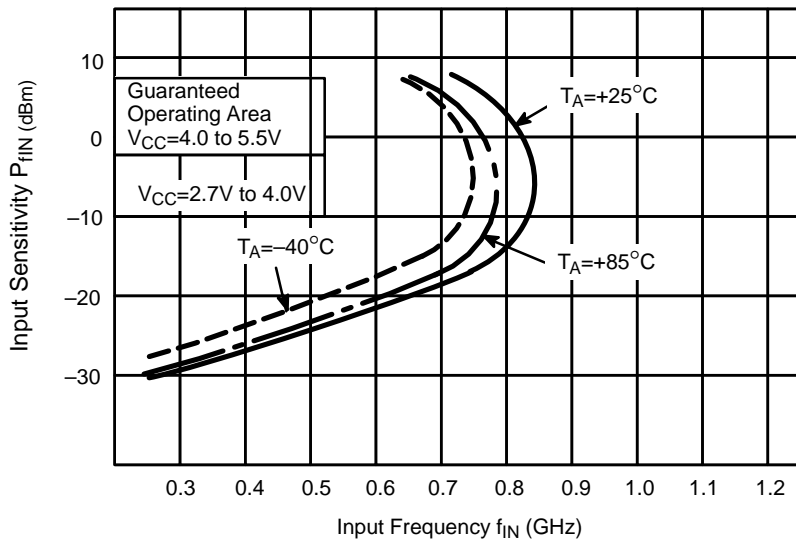

MB1504
MB1504H
MB1504L

INPUT IMPEDANCE

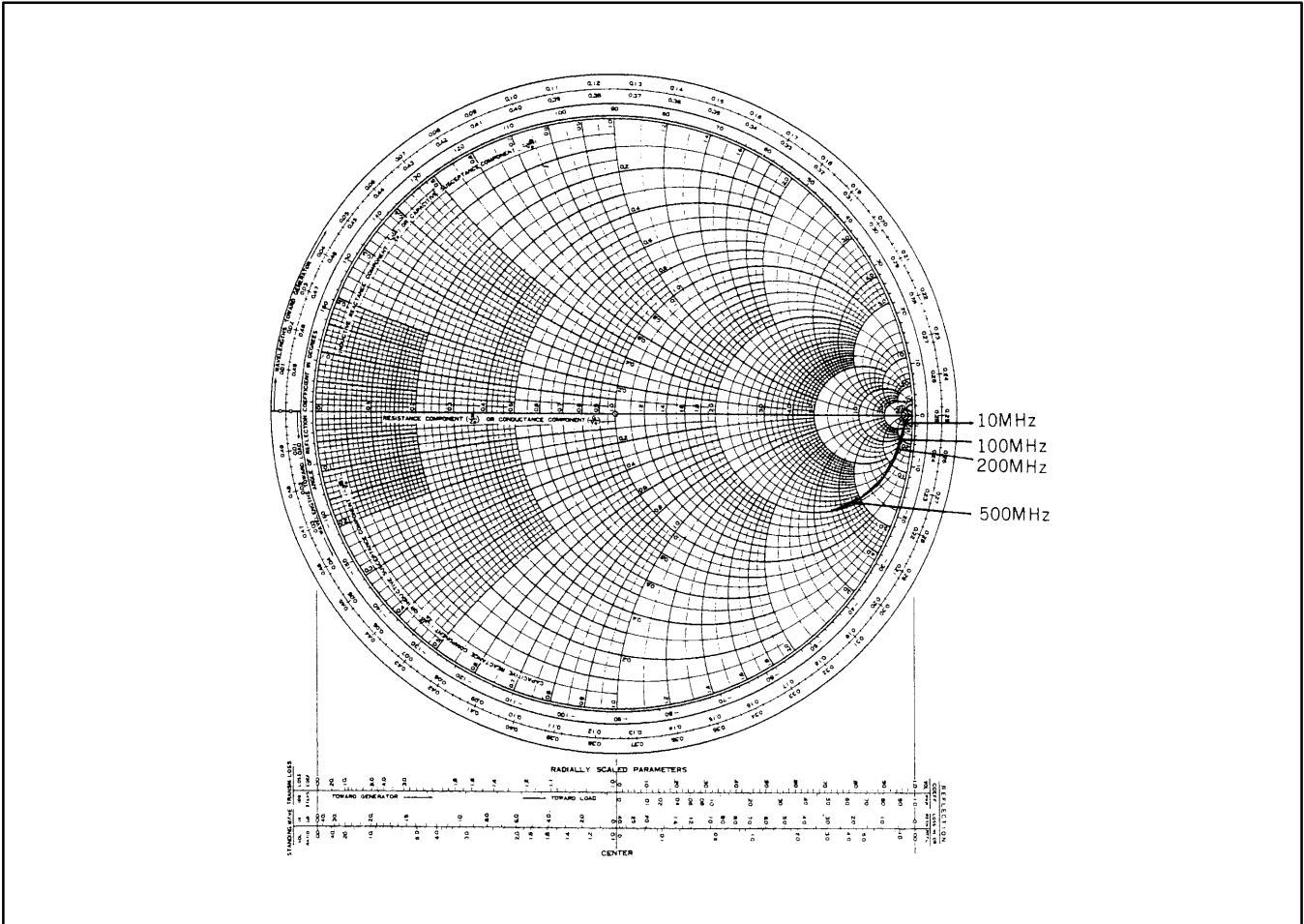

TEST CIRCUIT

D_O Pin Output Current (I_{OH}, I_{OL}) Measurement

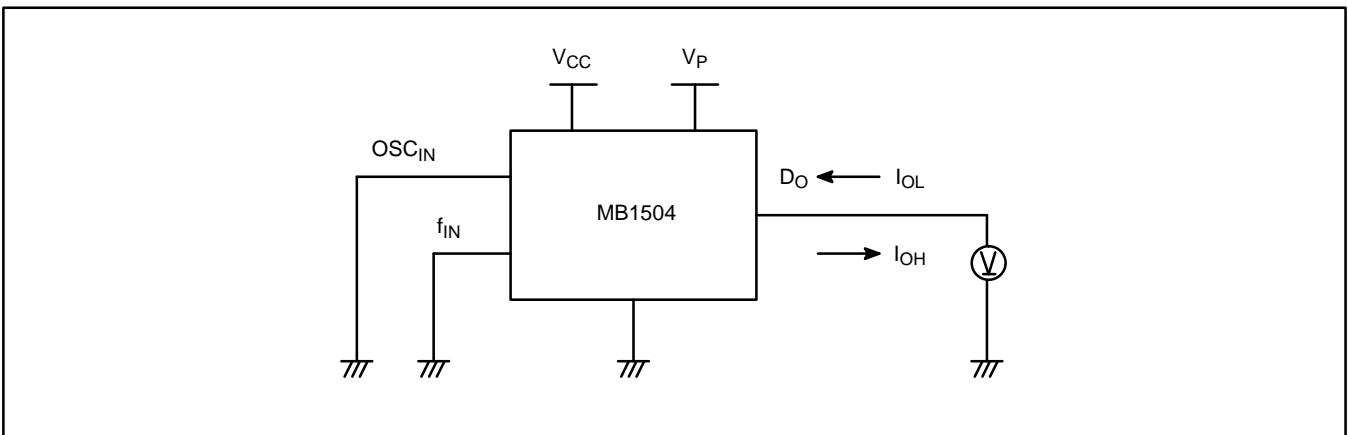

Lock up Time Measurement

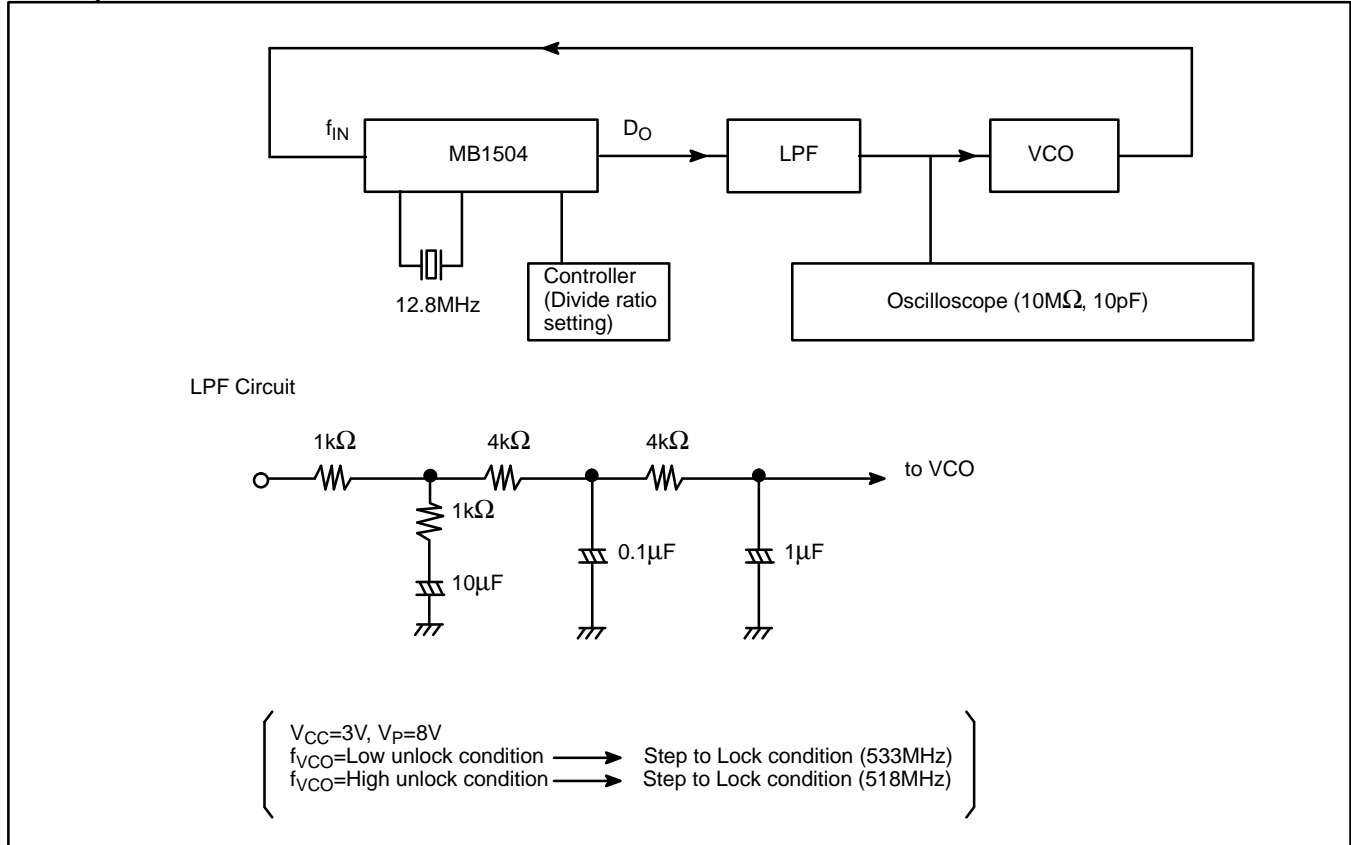

Phase Characteristics Measurement

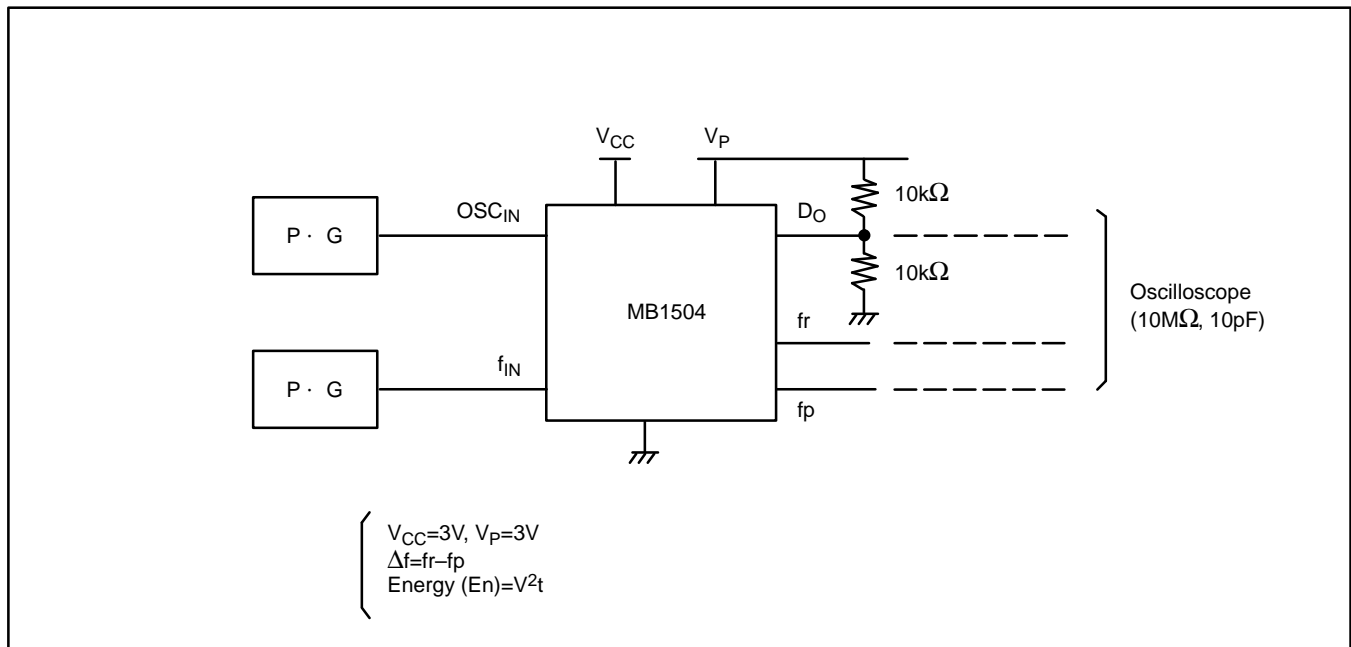

MB1504
 MB1504H
 MB1504L

TYPICAL APPLICATION EXAMPLE

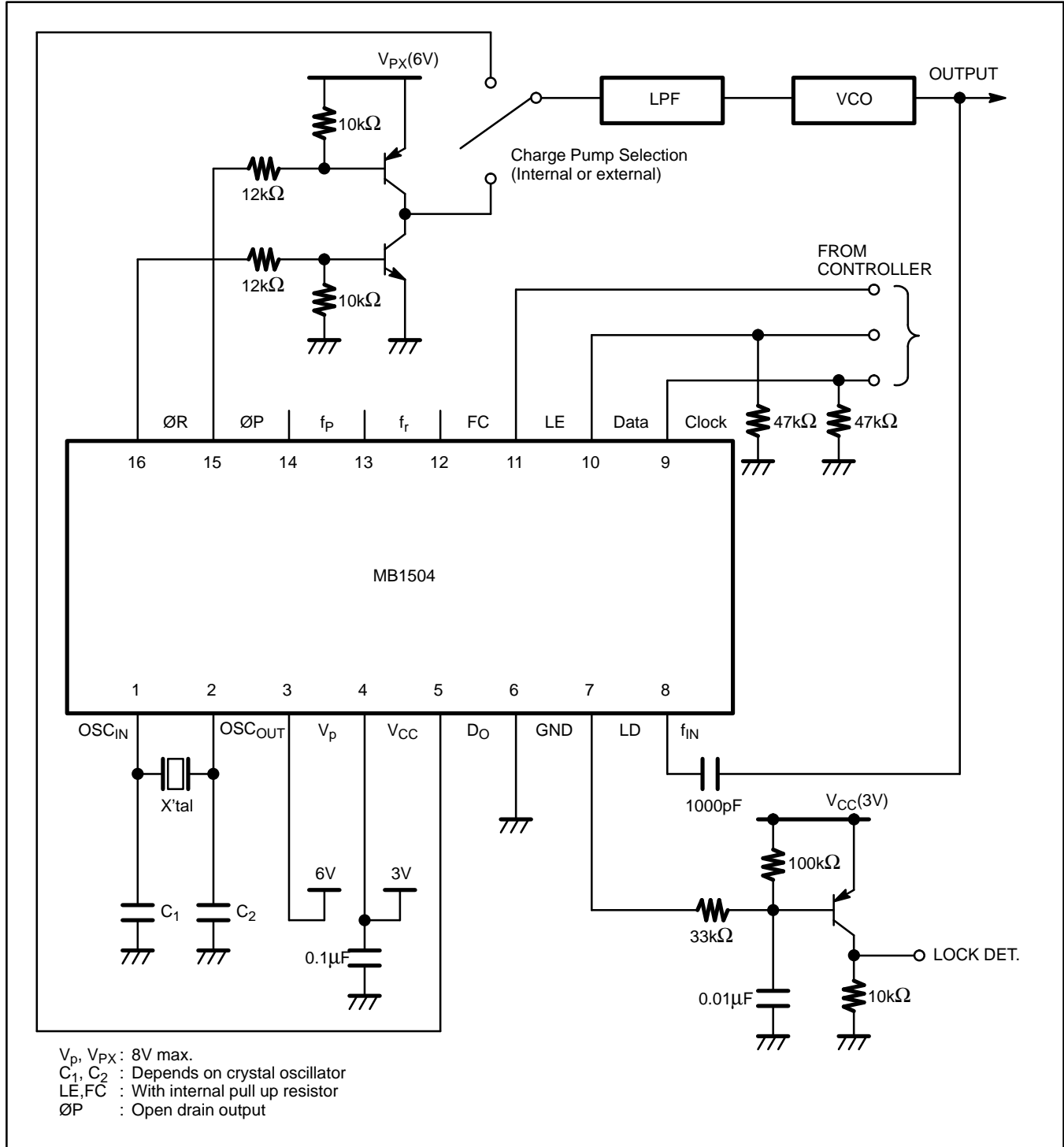

PACKAGE DIMENSIONS

16-LEAD PLASTIC DUAL IN-LINE PACKAGE
(Case No.: DIP-16P-M04)

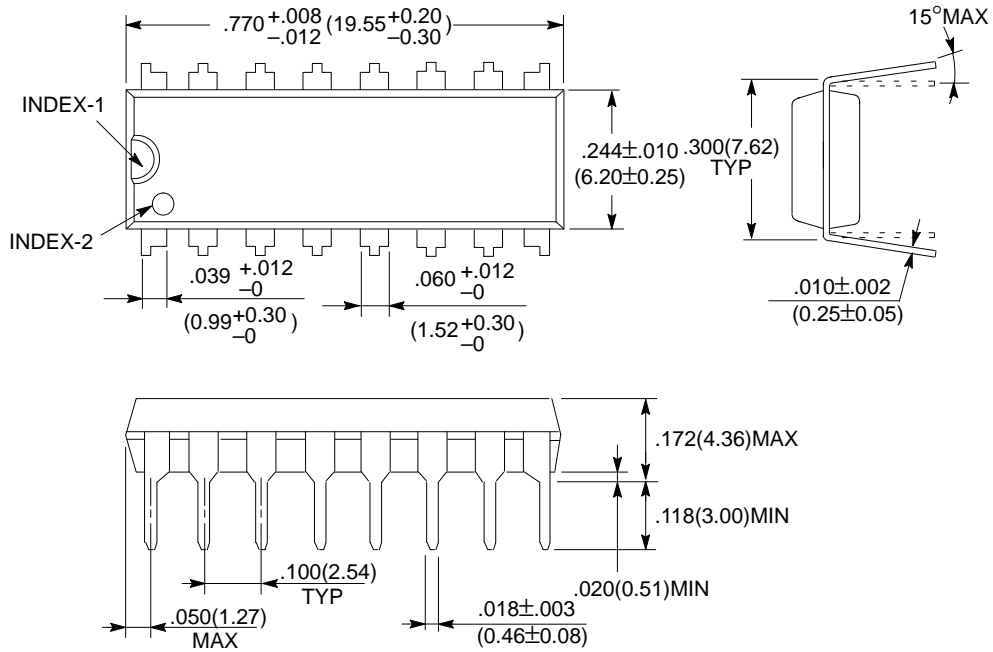

©1991 FUJITSU LIMITED D16033S-2C

Dimensions in
inches (millimeters)

MB1504
 MB1504H
 MB1504L

PACKAGE DIMENSIONS

16-LEAD PLASTIC FLAT PACKAGE (Case No.: FPT-16P-M06)

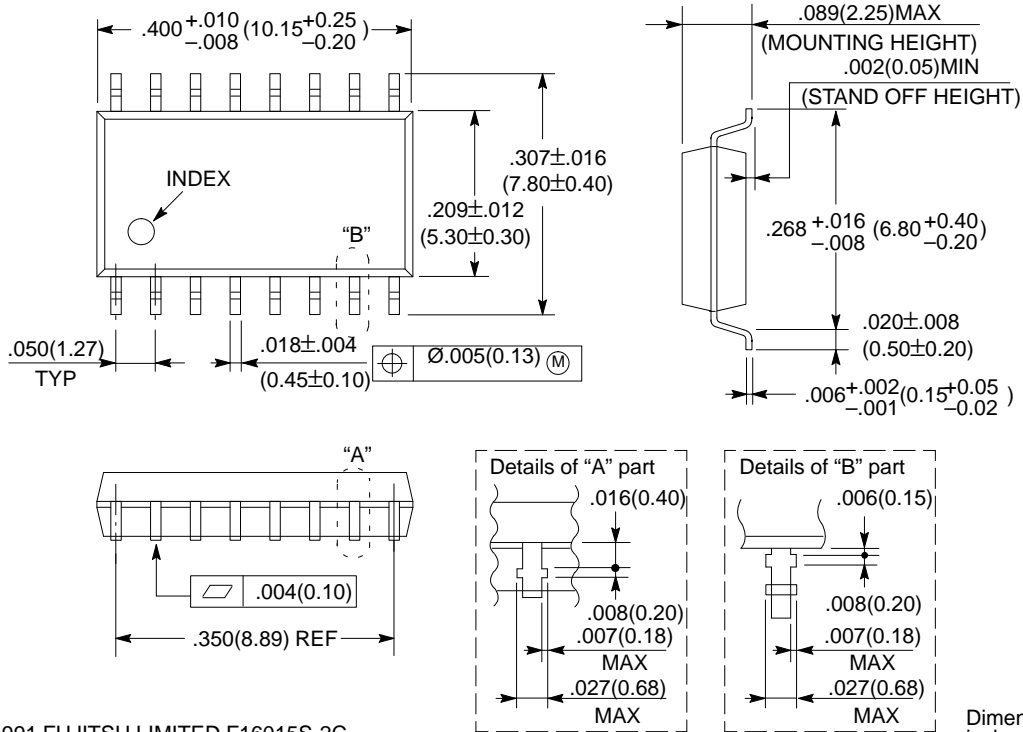

©1991 FUJITSU LIMITED F16015S-2C

Dimensions in inches (millimeters)

For further information please contact:

Japan

FUJITSU LIMITED
Electronic Devices
International Operations Department
KAWASAKI PLANT, 1015 Kamikodanaka,
Nakahara-ku, Kawasaki-shi,
Kanagawa 211, Japan
Tel: (044) 754-3753
FAX: (044) 754-3332

North and South America

FUJITSU MICROELECTRONICS, INC.
Semiconductor Division
3545 North First Street
San Jose, CA 95134-1804, USA
Tel: (408) 922-9000
FAX: (408) 432-9044/9045

Europe

FUJITSU MIKROELEKTRONIK GmbH
Am Siebenstein 6-10,
63303 Dreieich-Buchsschlag,
Germany
Tel: (06103) 690-0
FAX: (06103) 690-122

Asia Pacific

FUJITSU MICROELECTRONICS ASIA PTE LIMITED
No.51 Bras Basah Road,
Plaza By The Park,
#06-04 to #06-07
Singapore 0718
Tel: 336-1600
FAX: 336-1609