

ASSP

# Dual Serial Input PLL Frequency Synthesizer

## MB15F03SL

### DESCRIPTION

The Fujitsu MB15F03SL is a serial input Phase Locked Loop (PLL) frequency synthesizer with a 1750 MHz and a 600 MHz prescalers. The 1750 MHz prescaler, and 600 MHz prescaler have a dual modulus division ratio of 64/65 or 128/129 and 8/9 or 16/17 enabling pulse swallow operation.

The supply voltage range is between 2.4 V and 3.6 V.

The MB15F03SL uses the latest BiCMOS process. As a result, the supply current is typically 3.5 mA at 2.7 V. A refined charge pump supplies a well-balanced output current of 1.5 mA or 6 mA. The charge pump current is selectable by serial data.

MB15F03SL is ideally suited for wireless mobile communications, such as GSM and PDC.

### FEATURES

- High frequency operation: RF synthesizer: 1750 MHz max  
IF synthesizer: 600 MHz max
- Low power supply voltage:  $V_{CC} = 2.4$  to 3.6 V
- Ultra Low power supply current:  $I_{CC} = 3.5$  mA typ. ( $V_{CC} = 2.7$  V,  $T_a = +25^\circ\text{C}$ , in IF, RF locking state)  
 $I_{CC} = 4.0$  mA typ. ( $V_{CC} = 3.0$  V,  $T_a = +25^\circ\text{C}$ , in IF, RF locking state)
- Direct power saving function: Power supply current in power saving mode  
Typ. 0.1  $\mu\text{A}$  ( $V_{CC} = 3\text{V}$ ,  $T_a = +25^\circ\text{C}$ ), Max. 10  $\mu\text{A}$  ( $V_{CC} = 3\text{V}$ )
- Dual modulus prescaler: 1750 MHz prescaler (64/65 or 128/129)/600 MHz prescaler (8/9 or 16/17)
- Serial input 14-bit programmable reference divider:  $R = 3$  to 16,383
- Serial input programmable divider consisting of:
  - Binary 7-bit swallow counter: 0 to 127
  - Binary 11-bit programmable counter: 3 to 2,047
- Software selectable charge pump current
- On-chip phase control for phase comparator
- Operating temperature:  $T_a = -40$  to  $+85^\circ\text{C}$
- Pin compatible with MB15F03, MB15F03L

### PACKAGES

16-pin plastic SSOP

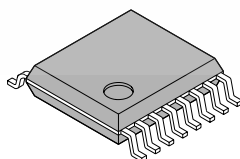

(FPT-16P-M05)

16-pad plastic BCC

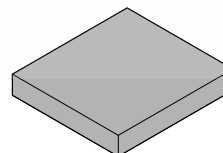

(LCC-16P-M04)

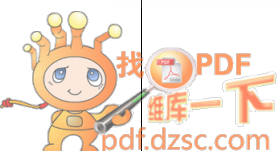

# MB15F03SL

## ■ PIN ASSIGNMENTS

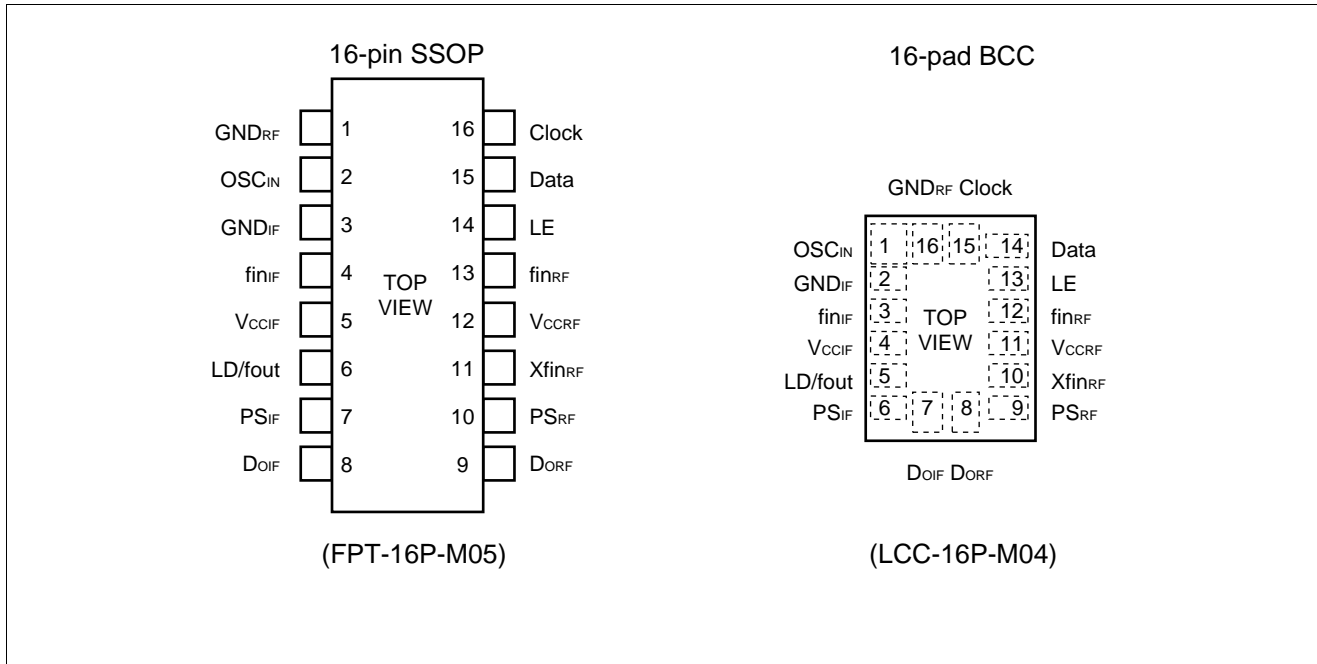

## ■ PIN DESCRIPTION

Pin no.		Pin name	I/O	Descriptions
SSOP	BCC			
1	16	GND <sub>RF</sub>	–	Ground for RF-PLL section.
2	1	OSC <sub>IN</sub>	I	The programmable reference divider input. TCXO should be connected with a AC coupling capacitor.
3	2	GND <sub>IF</sub>	–	Ground for the IF-PLL section.
4	3	fin <sub>IF</sub>	I	Prescaler input pin for the IF-PLL. Connection to an external VCO should be via AC coupling.
5	4	V <sub>CCIF</sub>	–	Power supply voltage input pin for the IF-PLL section.
6	5	LD/fout	O	Lock detect signal output (LD)/phase comparator monitoring output (fout). The output signal is selected by LDS bit in the serial data. LDS bit = "H" ; outputs fout signal LDS bit = "L" ; outputs LD signal
7	6	PS <sub>IF</sub>	I	Power saving mode control for the IF-PLL section. This pin must be set at "L" during Power-ON. (Open is prohibited.) PS <sub>IF</sub> = "H" ; Normal mode PS <sub>IF</sub> = "L" ; Power saving mode
8	7	Do <sub>IF</sub>	O	Charge pump output for the IF-PLL section. Phase characteristics of the phase detector can be selected via programming of the FC-bit.
9	8	Do <sub>RF</sub>	O	Charge pump output for the RF-PLL section. Phase characteristics of the phase detector can be selected via programming of the FC-bit.
10	9	PS <sub>RF</sub>	I	Power saving mode control for the RF-PLL section. This pin must be set at "L" during Power-ON. (Open is prohibited.) PS <sub>RF</sub> = "H" ; Normal mode PS <sub>RF</sub> = "L" ; Power saving mode
11	10	Xfin <sub>RF</sub>	I	Prescaler complementary input for the RE-PLL section. This pin should be grounded via a capacitor.
12	11	V <sub>CCRF</sub>	–	Power supply voltage input pin for the RF-PLL section, the shift register and the oscillator input buffer. When power is OFF, latched data of RF-PLL is lost.
13	12	fin <sub>RF</sub>	I	Prescaler input pin for the RF-PLL. Connection to an external VCO should be via AC coupling.
14	13	LE	I	Load enable signal input (with a schmitt trigger input buffer.) When the LE bit is set "H", data in the shift register is transferred to the corresponding latch according to the control bit in the serial data.
15	14	Data	I	Serial data input (with a schmitt trigger input buffer.) A data is transferred to the corresponding latch (IF-ref counter, IF-prog. counter, RF-ref. counter, RF-prog. counter) according to the control bit in the serial data.
16	15	Clock	I	Clock input for the 23-bit shift register (with a schmitt trigger input buffer.) One bit of data is shifted into the shift register on a rising edge of the clock.

# MB15F03SL

## ■ BLOCK DIAGRAM

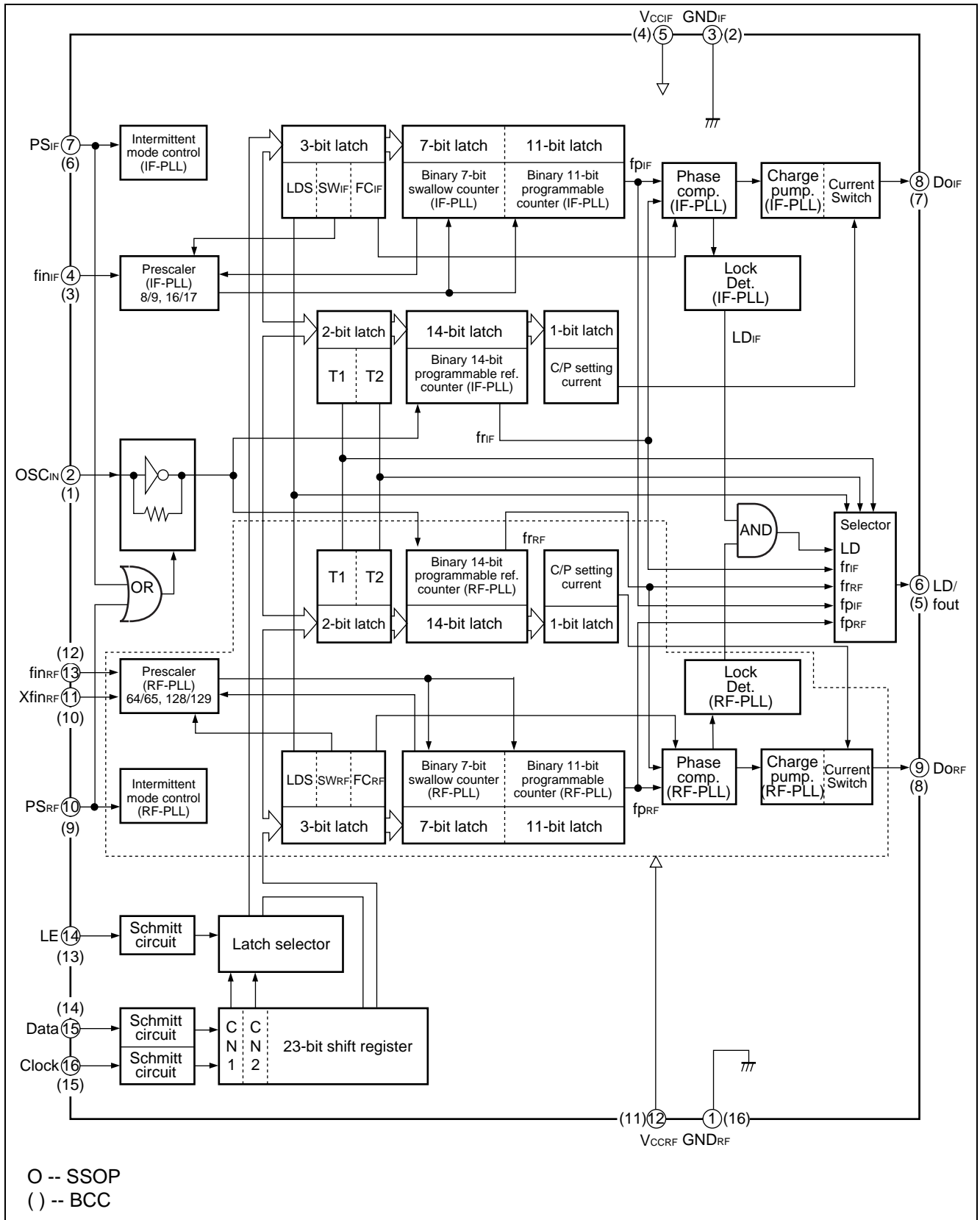

# MB15F03SL

## ■ ABSOLUTE MAXIMUM RATINGS

Parameter	Symbol	Rating		Unit	Remark
		Min.	Max.		
Power supply voltage	$V_{CC}$	-0.5	+4.0	V	
Input voltage	$V_i$	-0.5	$V_{CC} + 0.5$	V	
Output voltage	$V_o$	GND	$V_{CC}$	V	
Storage temperature	$T_{stg}$	-55	+125	°C	

WARNING: Semiconductor devices can be permanently damaged by application of stress (voltage, current, temperature, etc.) in excess of absolute maximum ratings. Do not exceed these ratings.

## ■ RECOMMENDED OPERATING CONDITIONS

Parameter	Symbol	Value			Unit	Remark
		Min.	Typ.	Max.		
Power supply voltage	$V_{CC}$	2.4	3.0	3.6	V	
Input voltage	$V_i$	GND	-	$V_{CC}$	V	
Operating temperature	$T_a$	-40	-	+85	°C	

WARNING: The recommended operating conditions are required in order to ensure the normal operation of the semiconductor device. All of the device's electrical characteristics are warranted when the device is operated within these ranges.

Always use semiconductor devices within their recommended operating condition ranges. Operation outside these ranges may adversely affect reliability and could result in device failure.

No warranty is made with respect to uses, operating conditions, or combinations not represented on the data sheet. Users considering application outside the listed conditions are advised to contact their FUJITSU representatives beforehand.

# MB15F03SL

## ■ ELECTRICAL CHARACTERISTICS

(V<sub>CC</sub> = 2.4 to 3.6 V, Ta = -40 to +85°C)

Parameter	Symbol	Condition	Value			Unit		
			Min.	Typ.	Max.			
Power supply current*1	I <sub>CCIF</sub> *1	fin <sub>IF</sub> = 223.15 MHz	V <sub>CCIF</sub> = 2.7 V	–	1.2	–	mA	
			(V <sub>CCIF</sub> = 3.0 V)		(1.5)			
	I <sub>CCRF</sub> *1	fin <sub>RF</sub> = 1750 MHz	V <sub>CCRF</sub> = 2.7 V	–	2.3	–	mA	
			(V <sub>CCRF</sub> = 3.0 V)		(2.5)			
Power saving current	I <sub>PSIF</sub>	PS <sub>IF</sub> = PS <sub>RF</sub> = "L"	–	0.1*2	10	μA		
	I <sub>PSRF</sub>	PS <sub>IF</sub> = PS <sub>RF</sub> = "L"	–	0.1*2	10	μA		
Operating frequency	fin <sub>IF</sub> *3	fin <sub>IF</sub>	IF PLL	50	–	600	MHz	
	fin <sub>RF</sub> *3	fin <sub>RF</sub>	RF PLL	100	–	1750	MHz	
	OSC <sub>IN</sub>	fosc	–	3	–	40	MHz	
Input sensitivity	fin <sub>IF</sub> *8	Pfin <sub>IF</sub>	IF PLL, 50 Ω system	–15	–	+2	dBm	
	fin <sub>RF</sub>	Pfin <sub>RF</sub>	RF PLL, 50 Ω system	–15	–	+2	dBm	
	OSC <sub>IN</sub>	V <sub>OSC</sub>	–	0.5		V <sub>CC</sub>	Vp-p	
"H" level input voltage	Data, Clock, LE,	V <sub>IH</sub>	Schmitt trigger input	$V_{CC} \times 0.7 + 0.4$	–	–	V	
"L" level input voltage		V <sub>IL</sub>	Schmitt trigger input	–	–	$V_{CC} \times 0.3 - 0.4$		
"H" level input voltage	PS	V <sub>IH</sub>	–	V <sub>CC</sub> × 0.7	–	–	V	
"L" level input voltage		V <sub>IL</sub>	–	–	–	V <sub>CC</sub> × 0.3		
"H" level input current	Data, Clock, LE, PS	I <sub>IH</sub> *4	–	–1.0	–	+1.0	μA	
"L" level input current		I <sub>IL</sub> *4	–	–1.0	–	+1.0		
"H" level input current	OSC <sub>IN</sub>	I <sub>IH</sub>	–	0	–	+100	μA	
"L" level input current		I <sub>IL</sub> *4	–	–100	–	0		
"H" level output voltage	LD/fout	V <sub>OH</sub>	V <sub>CC</sub> = 3 V, I <sub>OH</sub> = –1 mA	V <sub>CC</sub> – 0.4	–	–	V	
"L" level output voltage		V <sub>OL</sub>	V <sub>CC</sub> = 3 V, I <sub>OL</sub> = 1 mA	–	–	0.4		
"H" level output voltage	Do <sub>IF</sub> Do <sub>RF</sub>	V <sub>DOH</sub>	V <sub>CC</sub> = 3 V, I <sub>DOH</sub> = –0.5 mA	V <sub>CC</sub> – 0.4	–	–	V	
"L" level output voltage		V <sub>DOL</sub>	V <sub>CC</sub> = 3 V, I <sub>DOL</sub> = 0.5 mA	–	–	0.4		
High impedance cutoff current	Do <sub>IF</sub> Do <sub>RF</sub>	I <sub>OFF</sub>	V <sub>CC</sub> = 3 V, V <sub>OFF</sub> = 0.5 V to V <sub>CC</sub> – 0.5 V	–	–	2.5	nA	
"H" level output current	LD/fout	I <sub>OH</sub> *4	V <sub>CC</sub> = 3 V	–1.0	–	–	mA	
"L" level output current		I <sub>DOL</sub> *4	V <sub>CC</sub> = 3 V	–	–	1.0		
"H" level output current	Do <sub>IF</sub> Do <sub>RF</sub>	I <sub>DOH</sub> *4	V <sub>CC</sub> = 3 V, V <sub>DOH</sub> = V <sub>CC</sub> /2, Ta = +25°C	CS bit = "H"	–	–6.0	–	mA
				CS bit = "L"	–	–1.5	–	

(Continued)

# MB15F03SL

(Continued)

( $V_{CC} = 2.4$  to  $3.6$  V,  $T_a = -40$  to  $+85^\circ\text{C}$ )

Parameter	Symbol	Condition	Value			Unit		
			Min.	Typ.	Max.			
“L” level output current	$D_{OIF}$	$I_{DOL}$	$V_{CC} = 3$ V, $V_{DOL} = V_{CC}/2$ , $T_a = +25^\circ\text{C}$	CS bit = “H”	–	6.0	–	mA
	$D_{ORF}$			CS bit = “L”	–	1.5	–	
Charge pump current rate	$I_{DOL}/I_{DOH}$	$I_{DOMT}^{*5}$	$V_{DO} = V_{CC}/2$	–	3	–	%	
	vs $V_{DO}$	$I_{DOVD}^{*6}$	$0.5$ V $\leq V_{DO} \leq V_{CC} - 0.5$ V	–	10	–	%	
	vs $T_a$	$I_{DOTA}^{*7}$	$-40^\circ\text{C} \leq T_a \leq +85^\circ\text{C}$ , $V_{DO} = V_{CC}/2$	–	10	–	%	

\*1: Conditions;  $f_{osc} = 12$  MHz,  $T_a = +25^\circ\text{C}$ , in locking state.

\*2:  $V_{CCIF} = V_{CCRF} = 3.0$  V,  $f_{osc} = 12.8$  MHz,  $T_a = +25^\circ\text{C}$ , in power saving state.

\*3: AC coupling. 1000pF capacitor is connected under the condition of min. operating frequency.

\*4: The symbol “–” (minus) means direction of current flow.

\*5:  $V_{CC} = 3.0$  V,  $T_a = +25^\circ\text{C}$   $(|I_3| - |I_4|)/(|I_3| + |I_4|)/2 \times 100(\%)$

\*6:  $V_{CC} = 3.0$  V,  $T_a = +25^\circ\text{C}$   $(|I_2| - |I_1|)/2 / (|I_1| + |I_2|)/2 \times 100(\%)$  (Applied to each  $I_{DOL}$ ,  $I_{DOH}$ )

\*7:  $V_{CC} = 3.0$  V,  $(|I_{DO(85^\circ\text{C})} - I_{DO(-40^\circ\text{C})}|/2) / (|I_{DO(85^\circ\text{C})} + I_{DO(-40^\circ\text{C})}|/2) \times 100(\%)$  (Applied to each  $I_{DOL}$ ,  $I_{DOH}$ )

\*8: Prescaler divide ratio C/P current  $f_{in}$  operating frequency Input sensitivity

16/17	1.5 mA mode	$50$ MHz $\leq f_{in} \leq 600$ MHz	-15 dBm
	6.0 mA mode	$50$ MHz $\leq f_{in} \leq 300$ MHz	-15 dBm
8/9	1.5 mA mode	$300$ MHz $< f_{in} \leq 600$ MHz	-10 dBm
		$50$ MHz $\leq f_{in} \leq 300$ MHz	-15 dBm
	6.0 mA mode	$300$ MHz $< f_{in} \leq 600$ MHz*	-15 dBm
		$50$ MHz $\leq f_{in} \leq 300$ MHz	-15 dBm
		$300$ MHz $< f_{in} \leq 600$ MHz*	-10 dBm

\* :  $V_{CC} = 3.0$  V to  $3.6$  V at 600 MHz

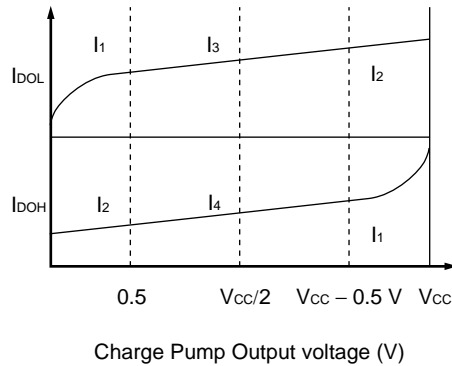

# MB15F03SL

## FUNCTIONAL DESCRIPTION

The divide ratio can be calculated using the following equation:

$$f_{vco} = [(M \times N) + A] \times f_{osc} \div R \quad (A < N)$$

- $f_{vco}$  : Output frequency of external voltage controlled oscillator (VCO)
- M : Preset divide ratio of dual modulus prescaler (8 or 16 for IF-PLL, 64 or 128 for RF-PLL)
- N : Preset divide ratio of binary 11-bit programmable counter (3 to 2,047)
- A : Preset divide ratio of binary 7-bit swallow counter ( $0 \leq A \leq 127$ )
- $f_{osc}$  : Reference oscillation frequency
- R : Preset divide ratio of binary 14-bit programmable reference counter (3 to 16,383)

### Serial Data Input

Serial data is entered using three pins, Data pin, Clock pin, and LE pin. Programmable dividers of IF/RF-PLL sections, programmable reference dividers of IF/RF-PLL sections are controlled individually.

Serial data of binary data is entered through Data pin.

On rising edge of Clock, one bit of serial data is transferred into the shift register. When the LE signal is taken high, the data stored in the shift register is transferred to one of latch of them depending upon the control bit data setting.

**Table.1 Control Bit**

Control bit		Destination of serial data
CN1	CN2	
L	L	The programmable reference counter for the IF-PLL
H	L	The programmable reference counter for the RF-PLL
L	H	The programmable counter and the swallow counter for the IF-PLL
H	H	The programmable counter and the swallow counter for the RF-PLL

### Shift Register Configuration

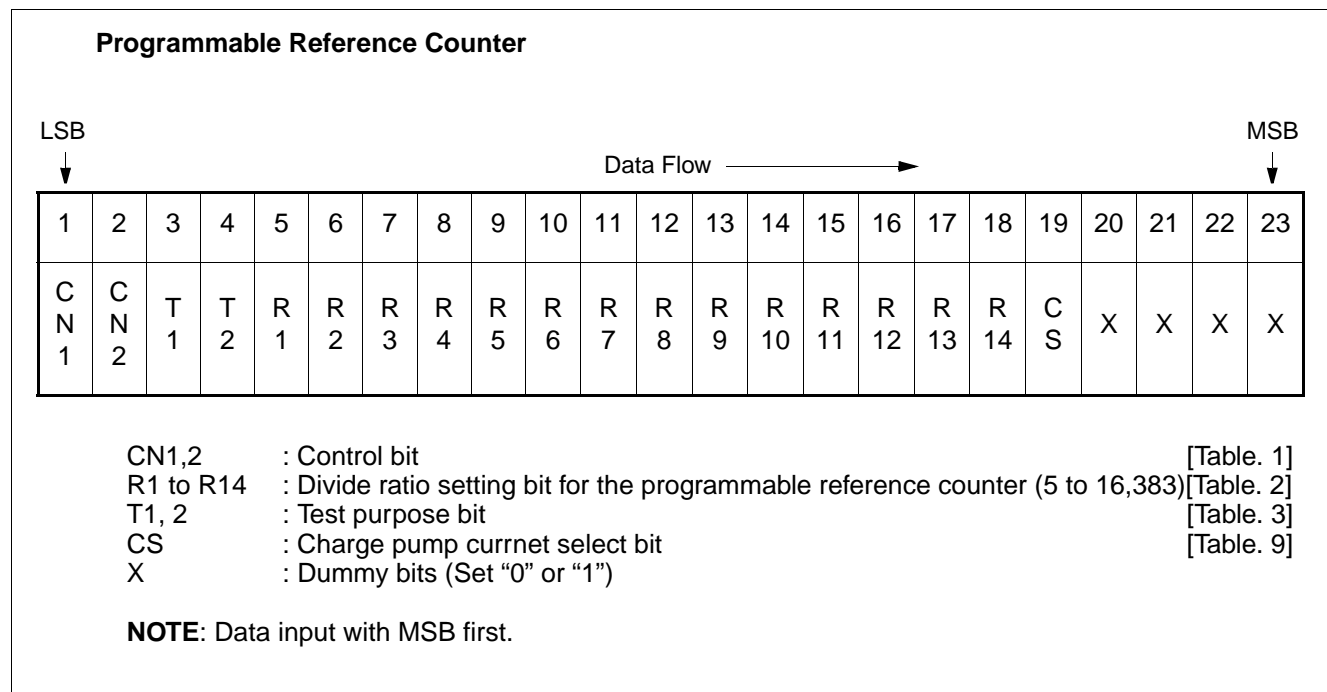



# MB15F03SL

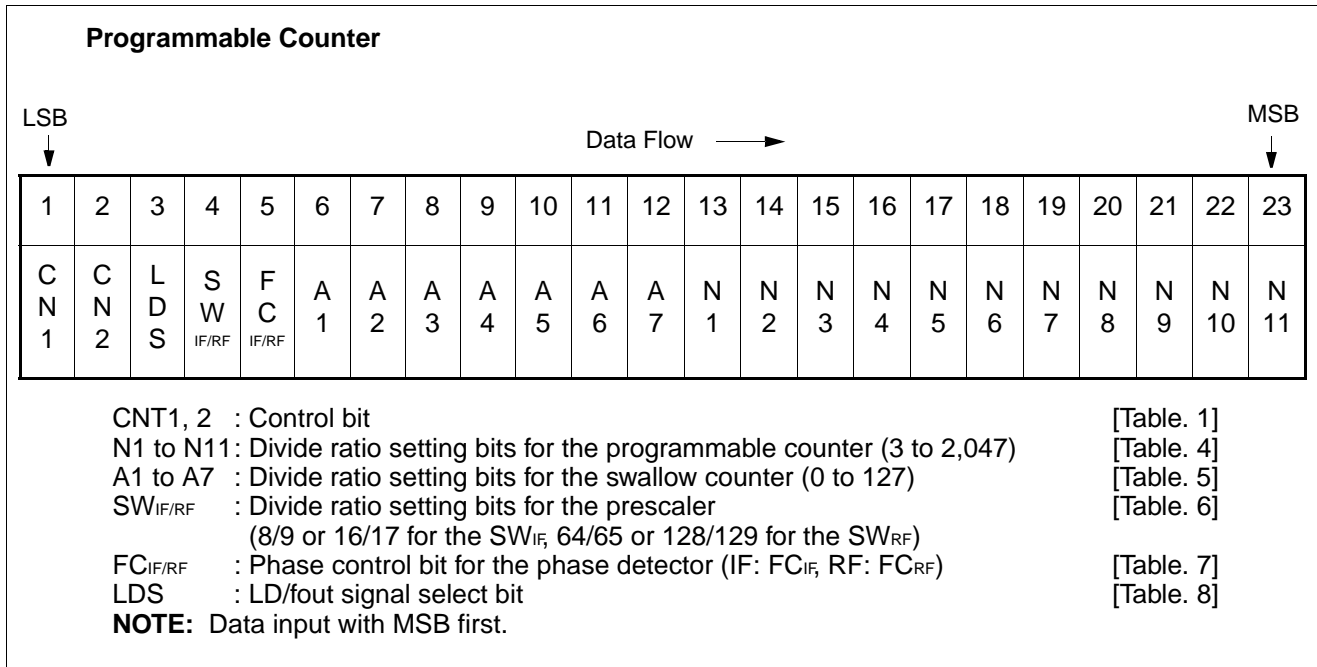

**Table2. Binary 14-bit Programmable Reference Counter Data Setting**

Divide ratio (R)	R <sub>14</sub>	R <sub>13</sub>	R <sub>12</sub>	R <sub>11</sub>	R <sub>10</sub>	R <sub>9</sub>	R <sub>8</sub>	R <sub>7</sub>	R <sub>6</sub>	R <sub>5</sub>	R <sub>4</sub>	R <sub>3</sub>	R <sub>2</sub>	R <sub>1</sub>
3	0	0	0	0	0	0	0	0	0	0	0	0	1	1
4	0	0	0	0	0	0	0	0	0	0	0	1	0	0
·	·	·	·	·	·	·	·	·	·	·	·	·	·	·
16383	1	1	1	1	1	1	1	1	1	1	1	1	1	1

Note: Divide ratio less than 3 is prohibited.

**Table.3 Test Purpose Bit Setting**

T <sub>1</sub>	T <sub>2</sub>	LD/fout pin state
L	L	Outputs fr <sub>IF</sub>
H	L	Outputs fr <sub>RF</sub>
L	H	Outputs fp <sub>IF</sub>
H	H	Outputs fp <sub>RF</sub>

# MB15F03SL

**Table.4 Brinary 11-bit Programmable Counter Data Setting**

Divide ratio (N)	N <sub>11</sub>	N <sub>10</sub>	N <sub>9</sub>	N <sub>8</sub>	N <sub>7</sub>	N <sub>6</sub>	N <sub>5</sub>	N <sub>4</sub>	N <sub>3</sub>	N <sub>2</sub>	N <sub>1</sub>
3	0	0	0	0	0	0	0	0	0	1	1
4	0	0	0	0	0	0	0	0	1	0	0
.	.	.	.	.	.	.	.	.	.	.	.
2047	1	1	1	1	1	1	1	1	1	1	1

Note: Divide ratio less than 3 is prohibited.

**Table.5 Brinary 7-bit Swallow Counter Data Setting**

Divide ratio (N)	A <sub>7</sub>	A <sub>6</sub>	A <sub>5</sub>	A <sub>4</sub>	A <sub>3</sub>	A <sub>2</sub>	A <sub>1</sub>
0	0	0	0	0	0	0	0
1	0	0	0	0	0	0	1
.	.	.	.	.	.	.	.
127	1	1	1	1	1	1	1

Note: Divide ratio (A) range = 0 to 127

**Table.6 Prescaler Data Setting**

		SW = "H"	SW = "L"
Prescaler divide ratio	IF-PLL	8/9	16/17
	RF-PLL	64/65	128/129

**Table.7 Phase Comparator Phase Switching Data Setting**

	FC <sub>IF, RE = H</sub>	FC <sub>IF, RE = L</sub>
	DO <sub>IF, RF</sub>	
fr > fp	H	L
fr = fp	Z	Z
fr < fp	L	H
VCO polarity	(1)	(2)

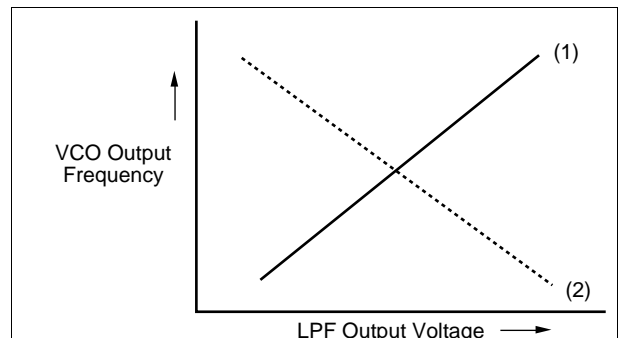

Note: Z = High-impedance  
Depending upon the VCO and LPF polarity, FC bit should be set.

**Table.8 LD/fout Output Select Data Setting**

LDS	LD/fout output signal
H	fout (fr <sub>IF/RF</sub> , fp <sub>IF/RF</sub> ) signals
L	LD signal

**Table.9 Charge Pump Current Setting**

CS	Current value
H	±6.0 mA
L	±1.5 mA

**Power Saving Mode (Intermittent Mode Control Circuit)**

**Table.10 PS Pin Setting**

PS pin	Status
H	Normal mode
L	Power saving mode

The intermittent mode control circuit reduces the PLL power consumption.  
 By setting the PS pin low, the device enters into the power saving mode, reducing the current consumption. See the Electrical Characteristics chart for the specific value.  
 The phase detector output, Do, becomes high impedance.  
 For the dual PLL, the lock detector, LD, is as shown in the LD Output Logic table.  
 Setting the PS pin high, releases the power saving mode, and the device works normally.  
 The intermittent mode control circuit also ensures a smooth startup when the device returns to normal operation. When the PLL is returned to normal operation, the phase comparator output signal is unpredictable. This is because of the unknown relationship between the comparison frequency (fp) and the reference frequency (fr) which can cause a major change in the comparator output, resulting in a VCO frequency jump and an increase in lockup time. To prevent a major VCO frequency jump, the intermittent mode control circuit limits the magnitude of the error signal from the phase detector when it returns to normal operation.

- Note: When power (Vcc) is first applied, the device must be in standby mode, PS = Low, for at least 1 μs.
- Note: PS pin must be set "L" for Power-ON.

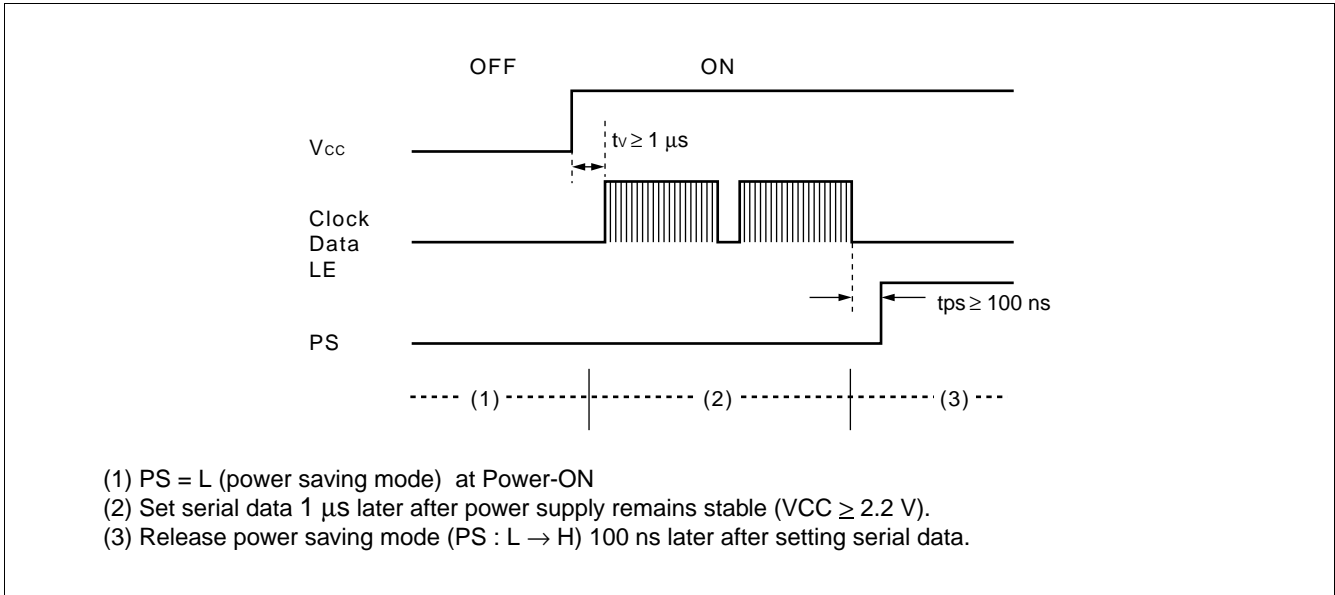

# MB15F03SL

## ■ SERIAL DATA INPUT TIMING

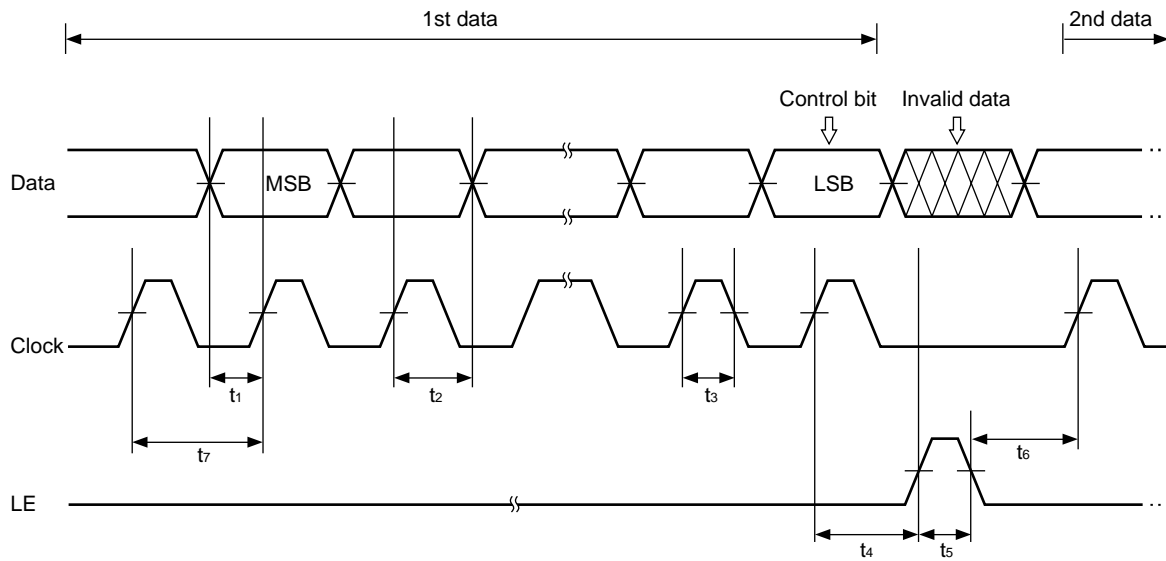

On rising edge of the clock, one bit of the data is transferred into the shift register.

Parameter	Min.	Typ.	Max.	Unit
t1	20	–	–	ns
t2	20	–	–	ns
t3	30	–	–	ns
t4	30	–	–	ns

Parameter	Min.	Typ.	Max.	Unit
t5	100	–	–	ns
t6	20	–	–	ns
t7	100	–	–	ns

Note: LE should be “L” when the data is transferred into the shift register.

## ■ PHASE COMPARATOR OUTPUT WAVEFORM

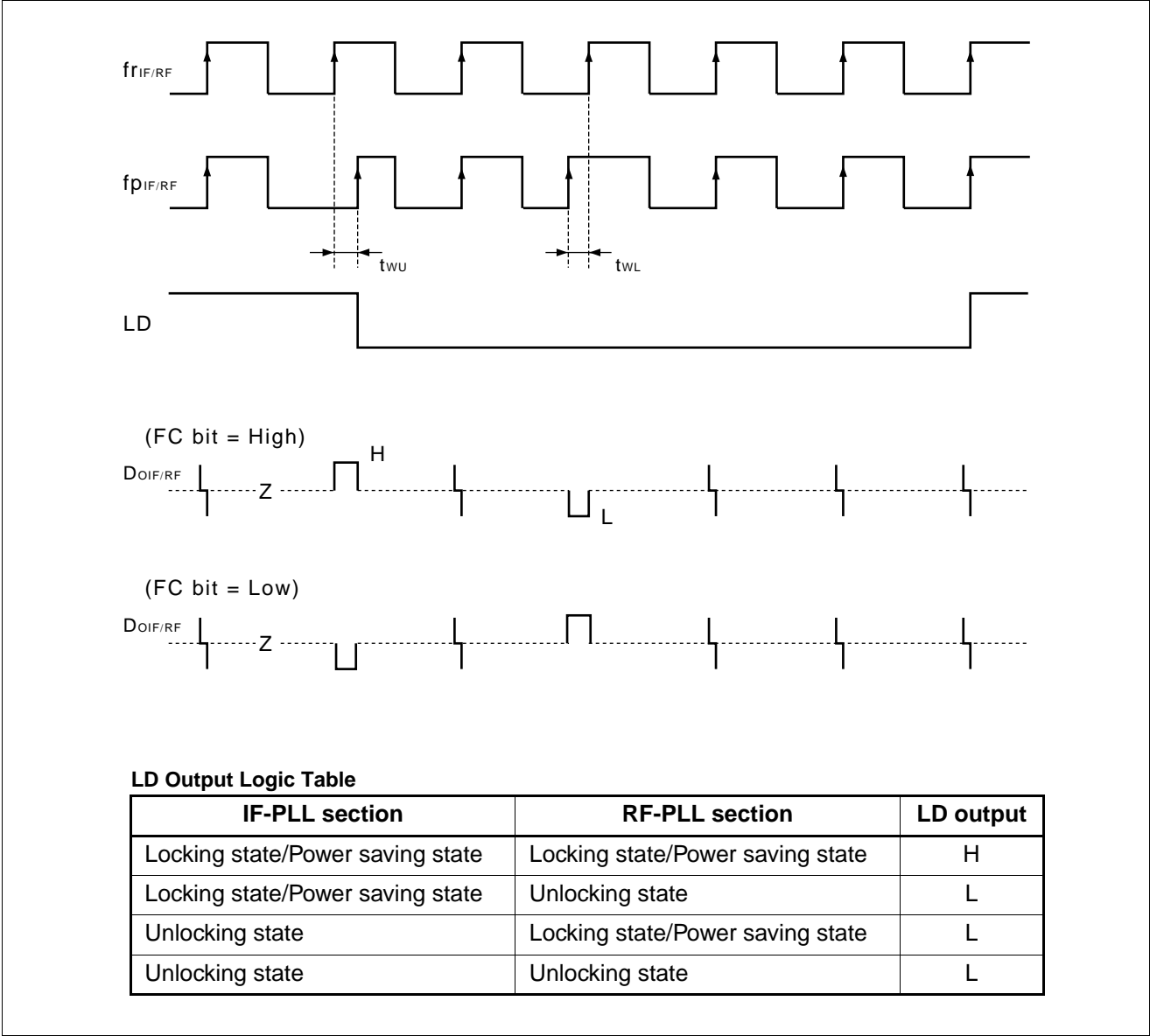

- Notes:
- Phase error detection range =  $-2\pi$  to  $+2\pi$
  - Pulses on  $D_{oIF/RF}$  signals are output to prevent dead zone.
  - LD output becomes low when phase error is  $t_{WU}$  or more.
  - LD output becomes high when phase error is  $t_{WL}$  or less and continues to be so for three cycles or more.
  - $t_{WU}$  and  $t_{WL}$  depend on  $OSC_{in}$  input frequency as follows.  
 $t_{WU} \geq 2/f_{osc}$ : i. e.  $t_{WU} \geq 156.3$  ns when  $f_{oscin} = 12.8$  MHz  
 $t_{WL} \leq 4/f_{osc}$ : i. e.  $t_{WL} \leq 312.5$  ns when  $f_{oscin} = 12.8$  MHz

# MB15F03SL

## MEASUREMENT CIRCUIT (for Measuring Input Sensitivity $f_{in}/OSC_{in}$ )

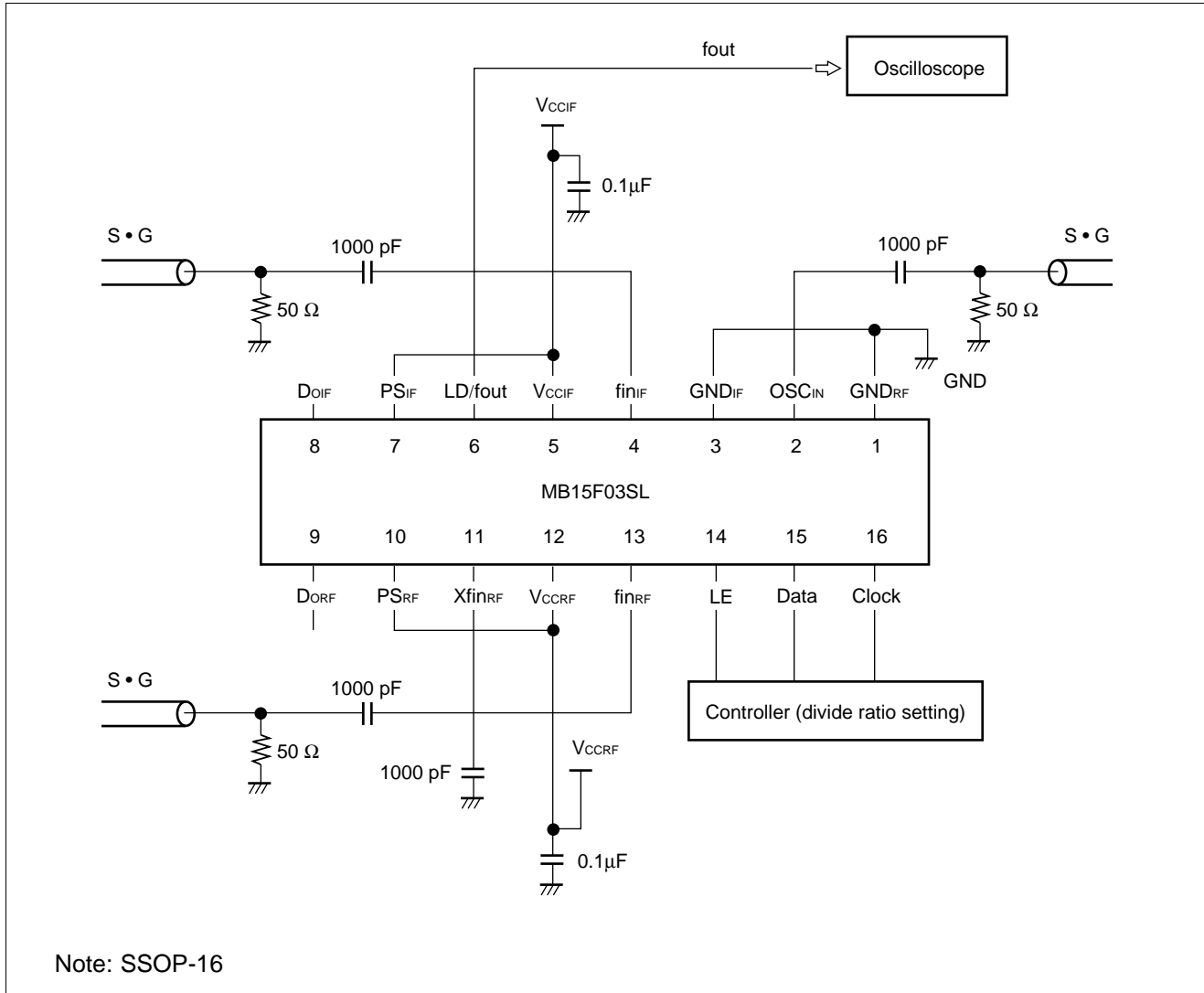

## TYPICAL CHARACTERISTICS

### 1. fin input sensitivity

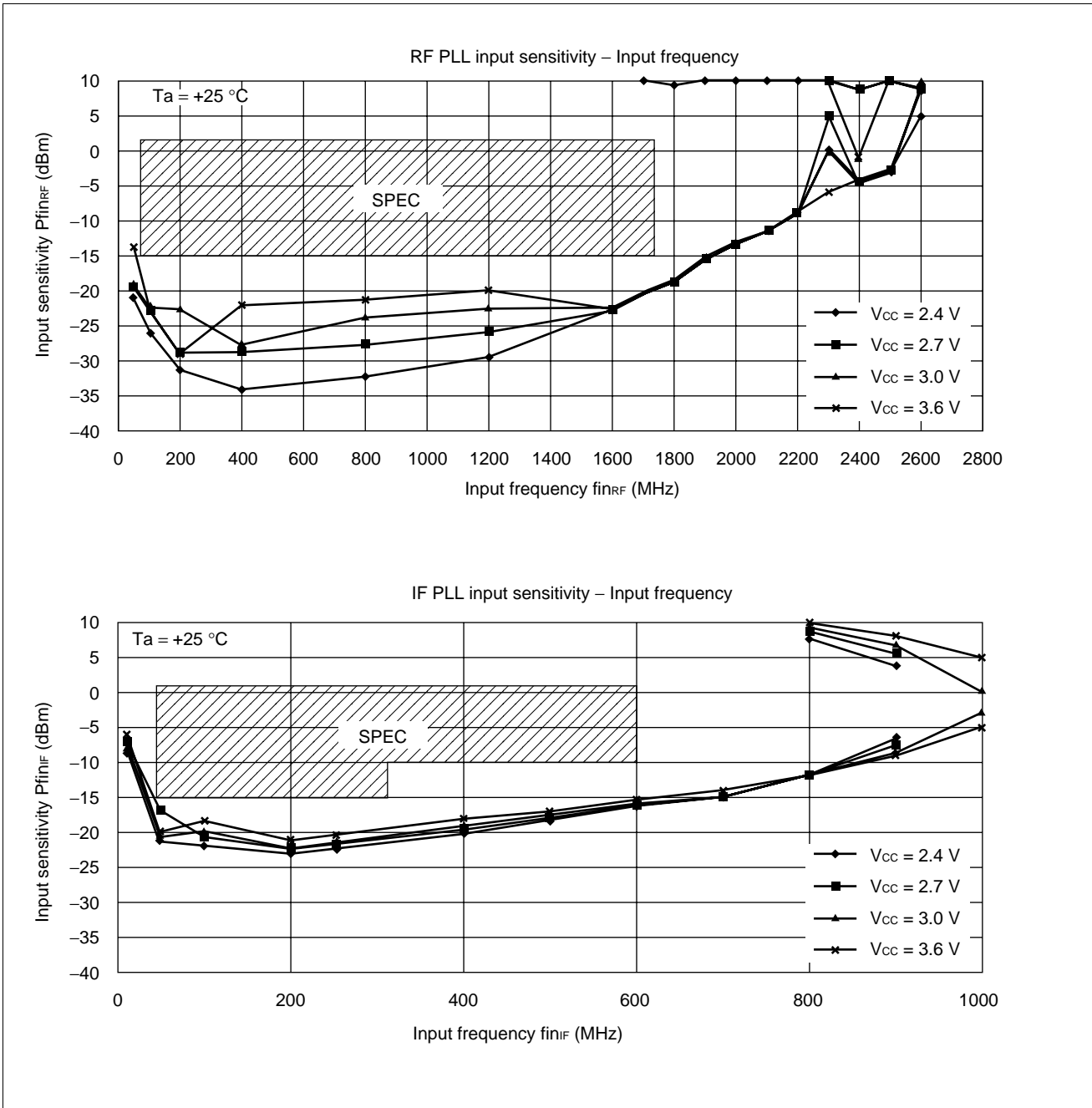

# MB15F03SL

## 2. OSC<sub>IN</sub> input sensitivity

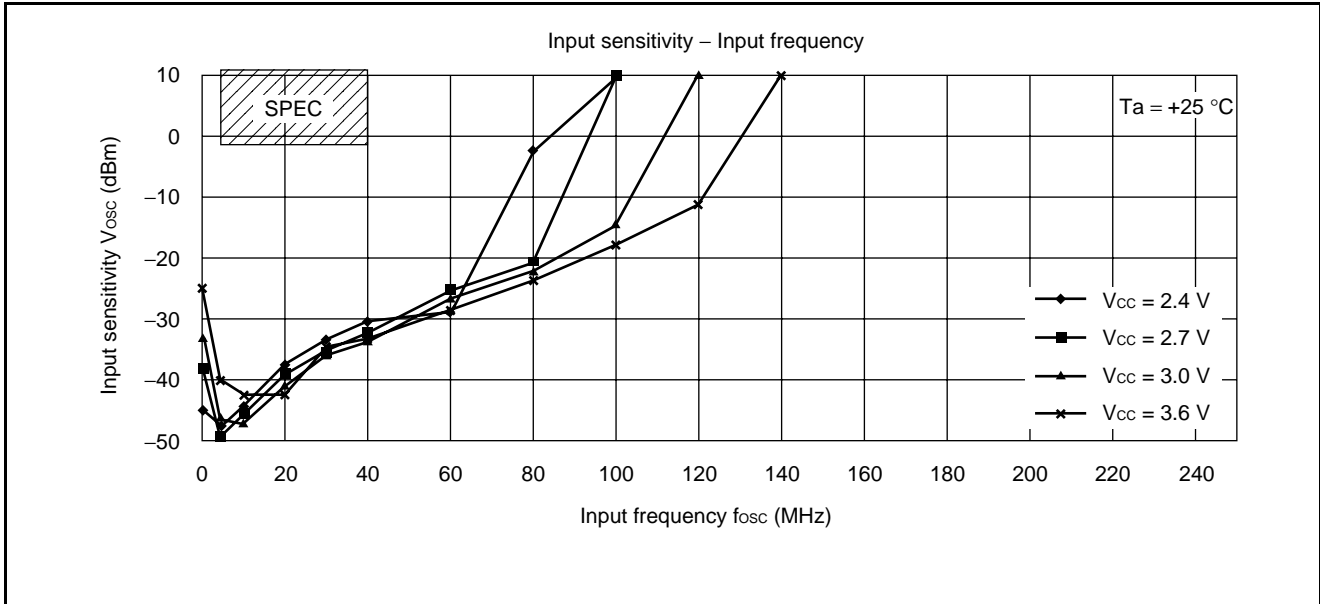



3. Do output current (RF PLL)

1.5 mA mode

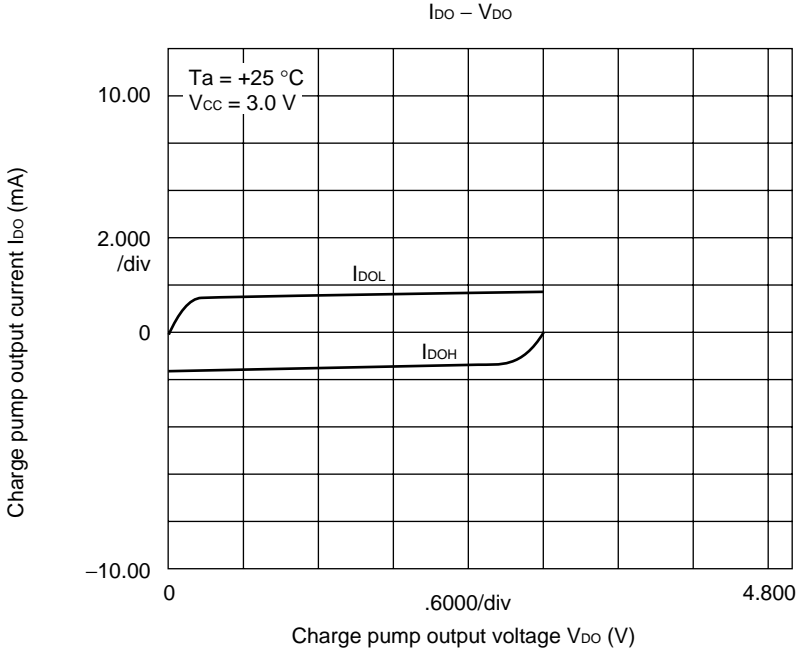

6.0 mA mode

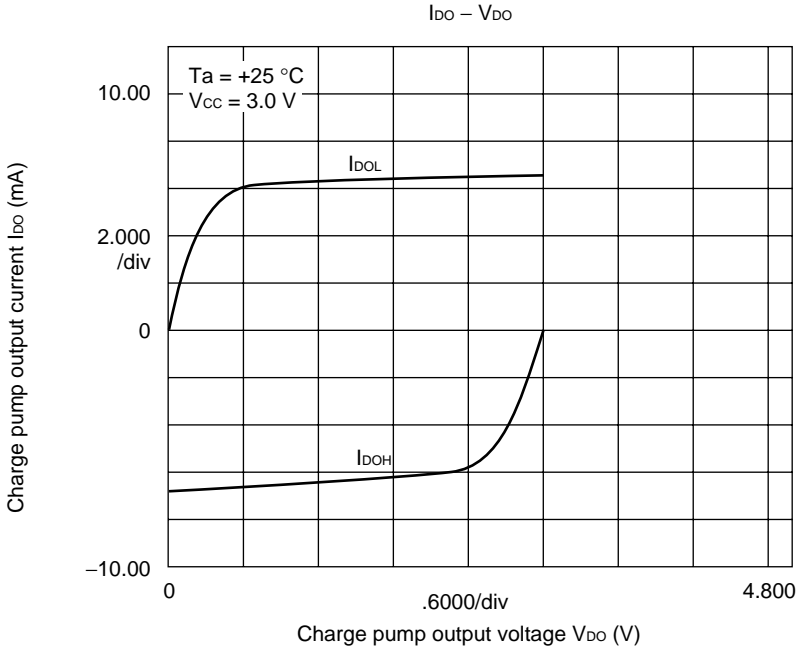

# MB15F03SL

## 4. Do output current (IF PLL)

1.5 mA mode

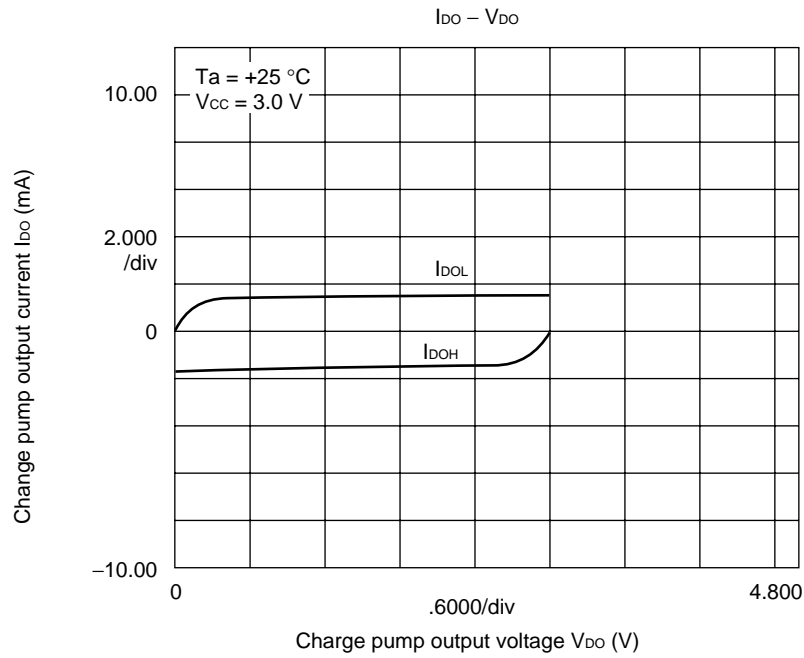

6.0 mA mode

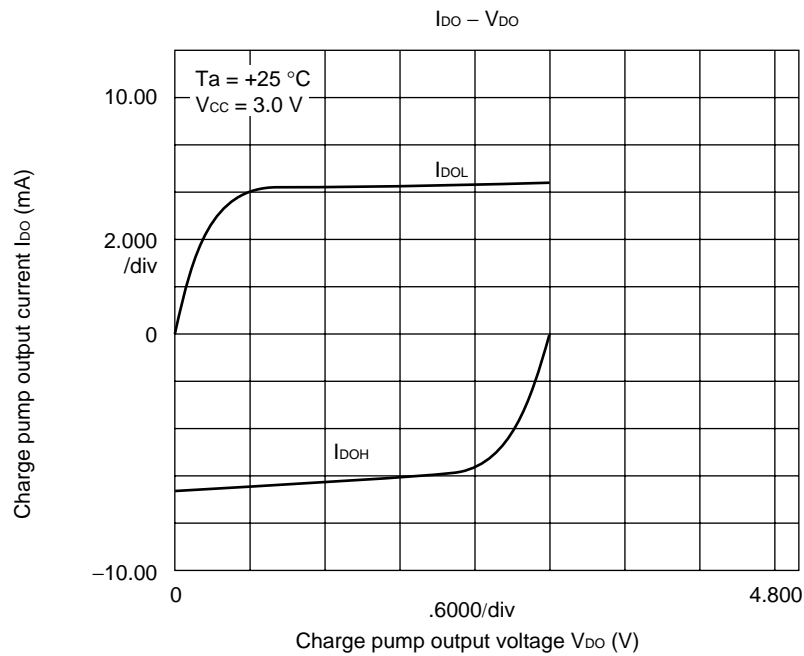

## 5. fin input impedance

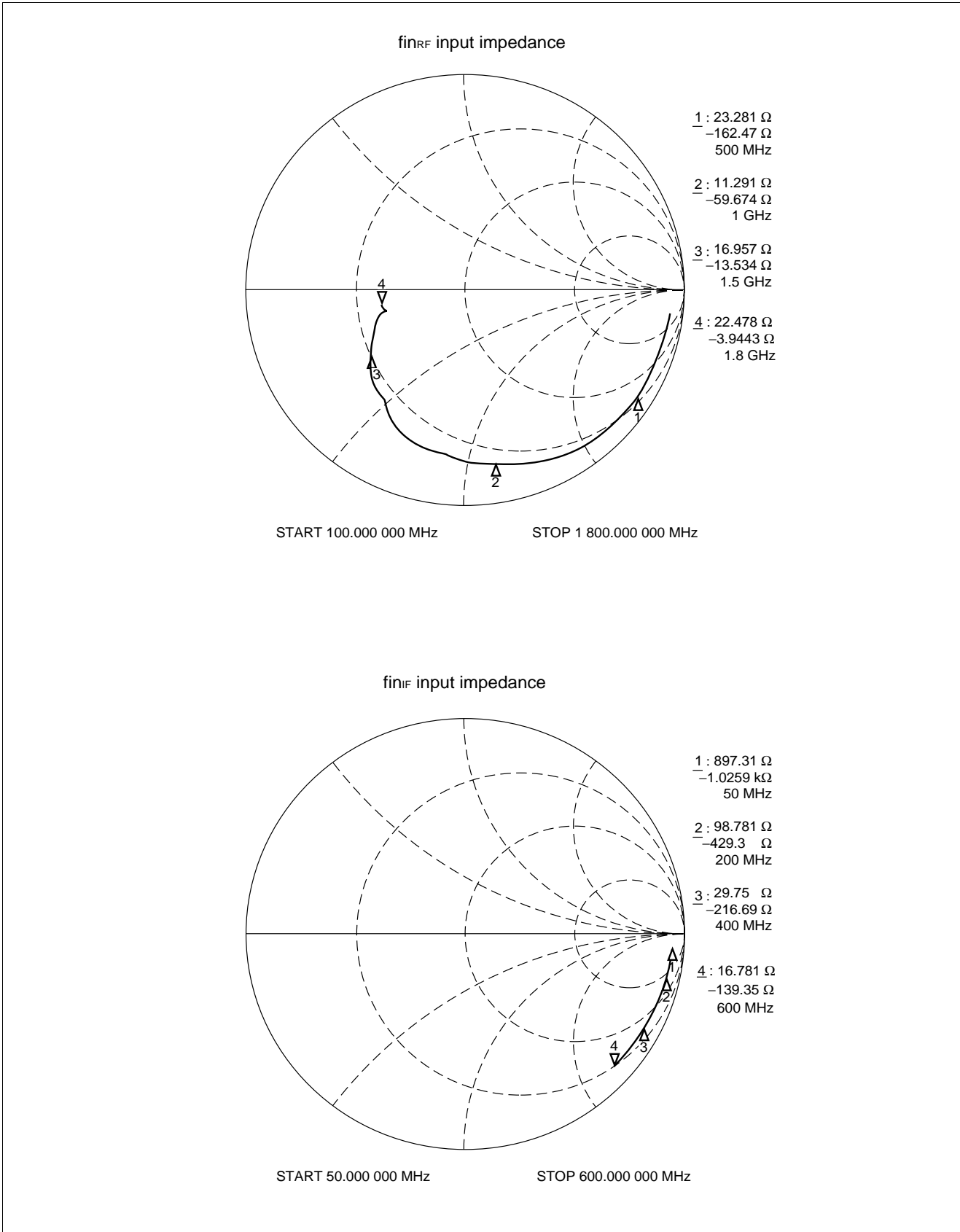

# MB15F03SL

## 6. OSC<sub>IN</sub> input impedance

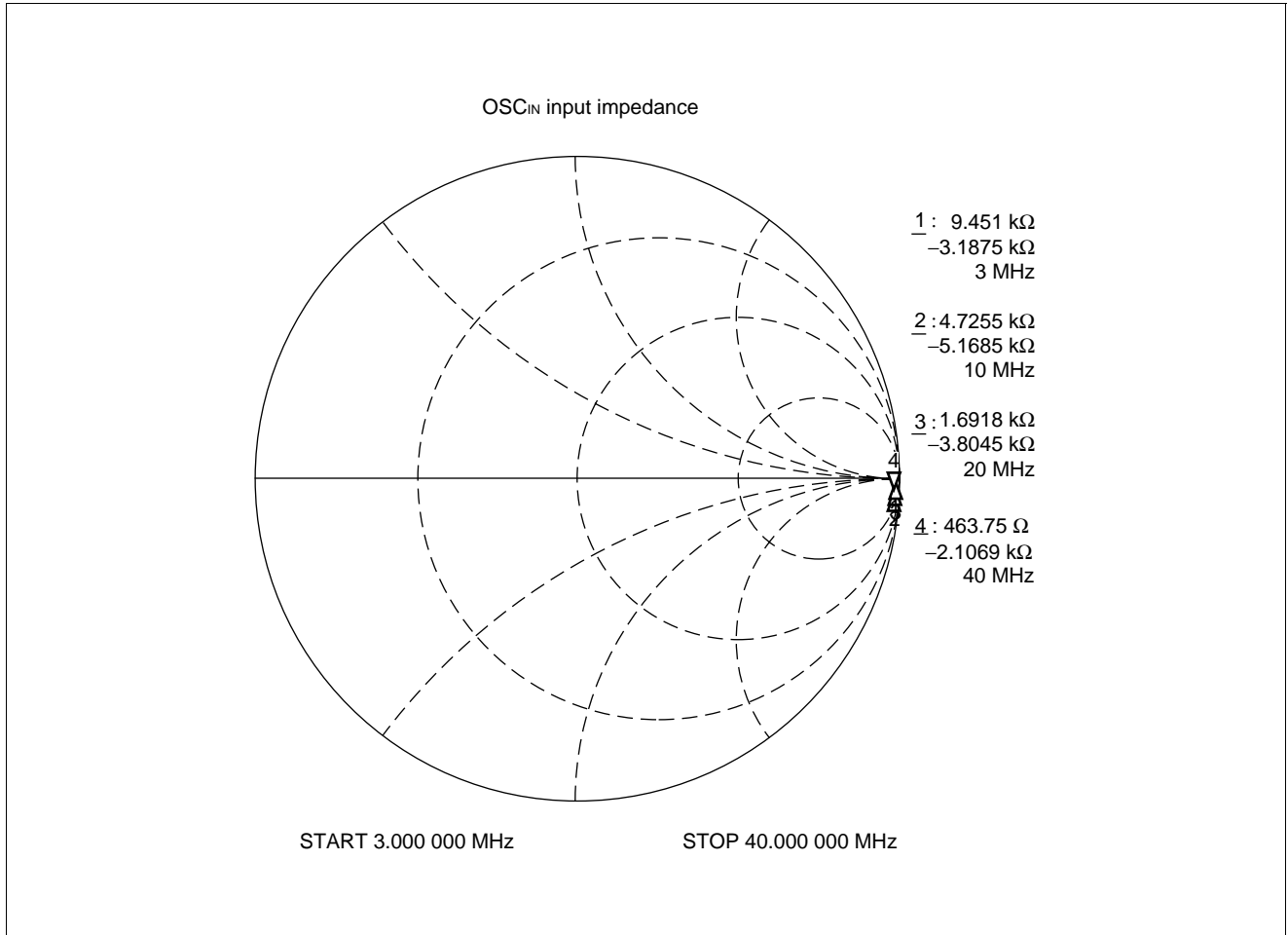

## APPLICATION EXAMPLE

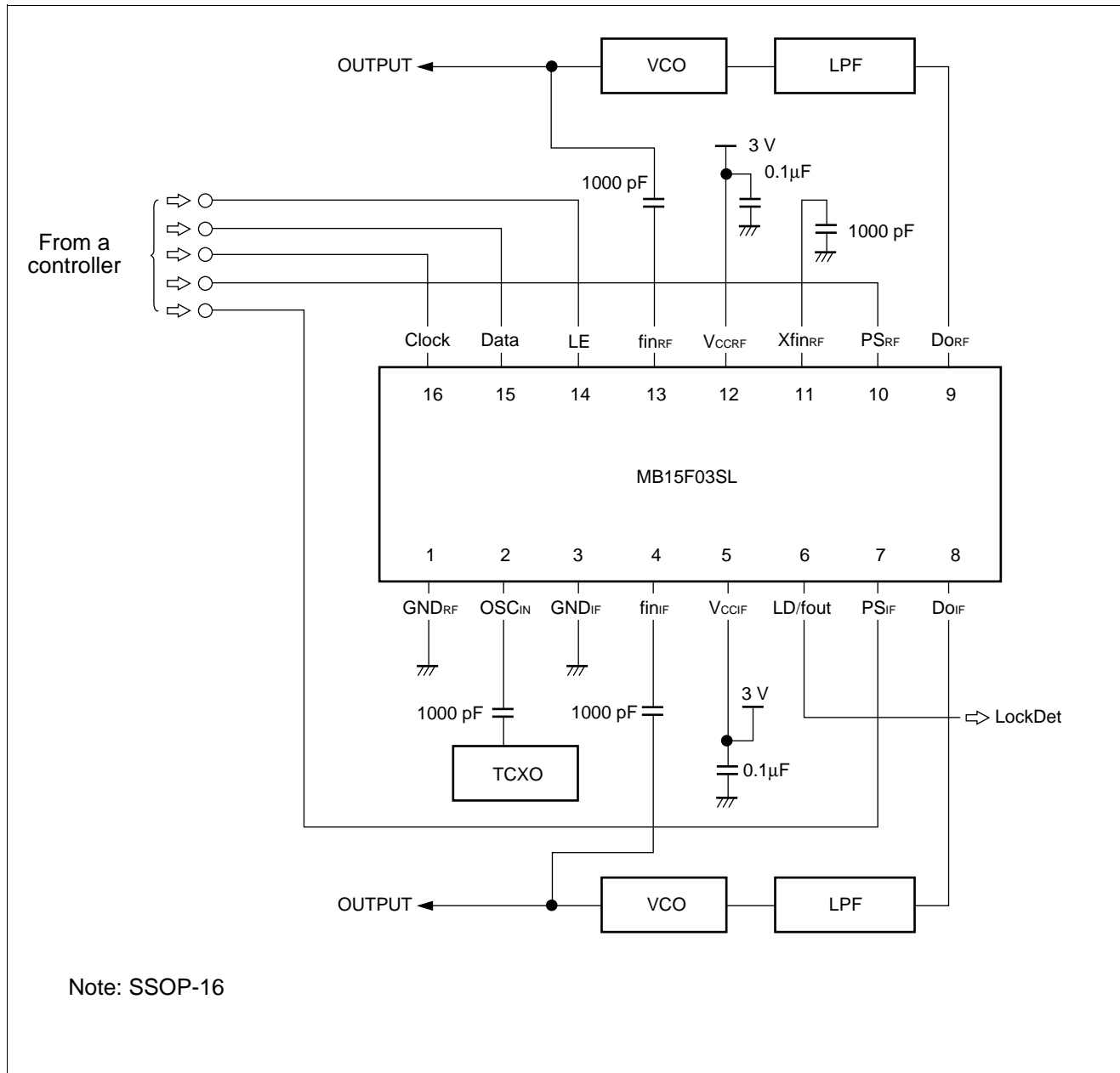

## USAGE PRECAUTIONS

- (1)  $V_{CCRF}$  must equal  $V_{CCIF}$ .  
Even if either RF-PLL or IF-PLL is not used, power must be supplied to both  $V_{CCRF}$  and  $V_{CCIF}$  to keep them equal. It is recommended that the non-use PLL is controlled by power saving function.
- (2) To protect damage by electrostatic discharge, note the following handling precautions:
  - Store and transport devices in conductive containers.
  - Use properly grounded workstations, tools, and equipment.
  - Turn off power before inserting or removing this device into or from a socket.
  - Protect leads with conductive sheet, when transporting a board mounted device.

# MB15F03SL

## ■ ORDERING INFORMATION

Part number	Package	Remarks
MB15F03SLPFV1	16-pin, plastic SSOP (FPT-16P-M05)	
MB15F03SLPV1	16-pad, plastic BCC (LCC-16P-M04)	

# MB15F03SL

## PACKAGE DIMENSIONS

16-pin plastic SSOP  
(FPT-16P-M05)

\* : These dimensions do not include resin protrusion.

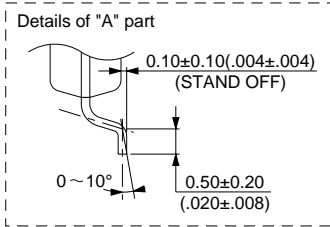
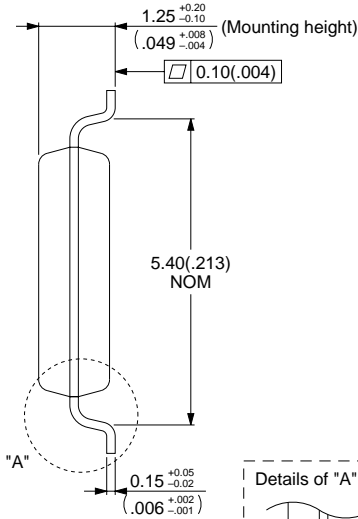
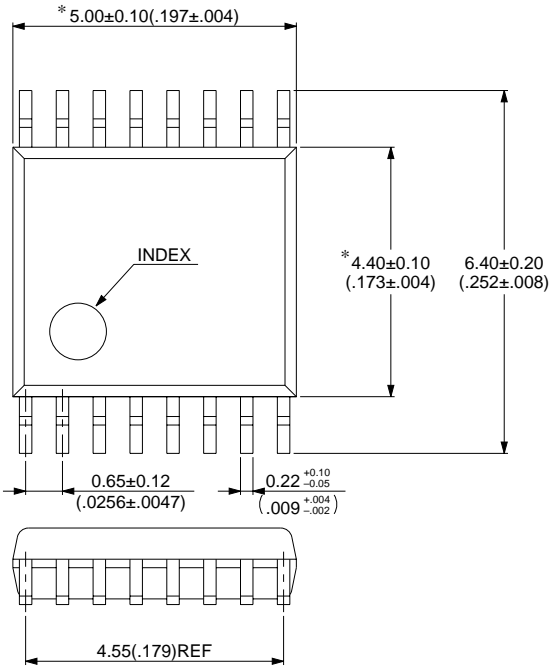

Dimensions in mm (inches)

(Continued)

# MB15F03SL

(Continued)

16-pad plastic BCC  
(LCC-16P-M04)

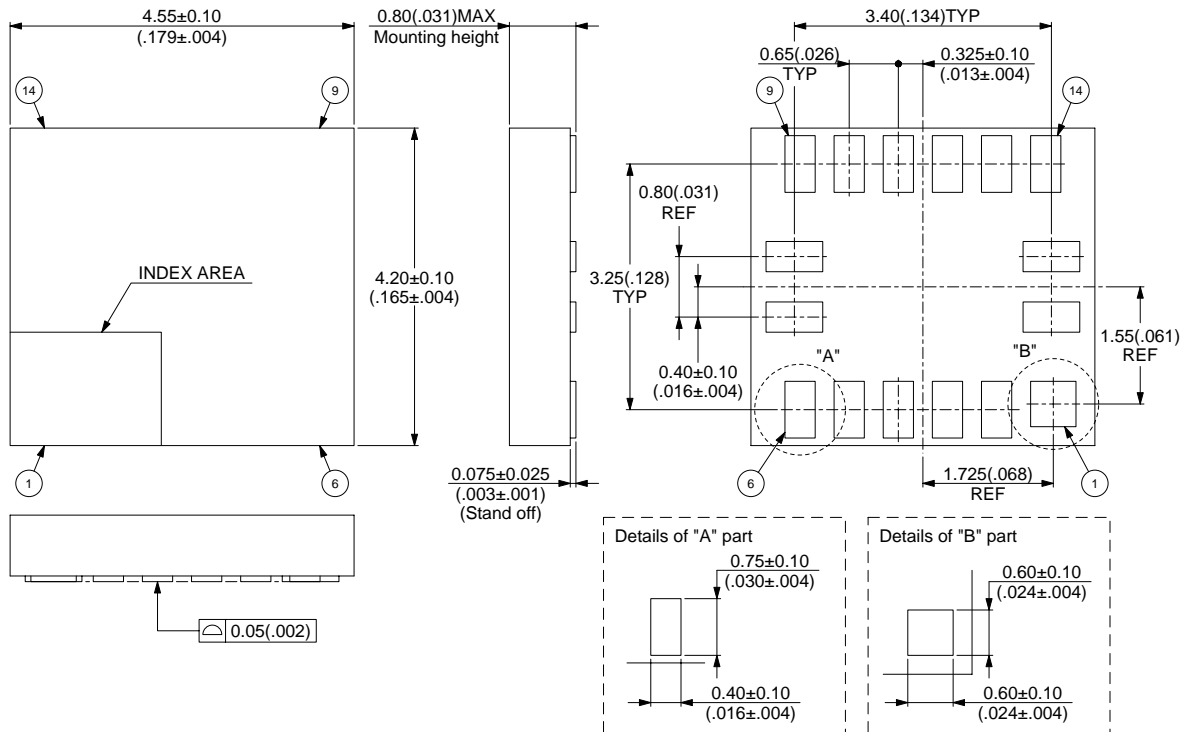

© 1999 FUJITSU LIMITED C16015S-1C-1

Dimensions in mm (inches)



## FUJITSU LIMITED

*For further information please contact:*

### **Japan**

FUJITSU LIMITED  
Corporate Global Business Support Division  
Electronic Devices  
KAWASAKI PLANT, 4-1-1, Kamikodanaka  
Nakahara-ku, Kawasaki-shi  
Kanagawa 211-8588, Japan  
Tel: 81(44) 754-3763  
Fax: 81(44) 754-3329

<http://www.fujitsu.co.jp/>

### **North and South America**

FUJITSU MICROELECTRONICS, INC.  
Semiconductor Division  
3545 North First Street  
San Jose, CA 95134-1804, USA  
Tel: (408) 922-9000  
Fax: (408) 922-9179

Customer Response Center  
*Mon. - Fri.: 7 am - 5 pm (PST)*  
Tel: (800) 866-8608  
Fax: (408) 922-9179

<http://www.fujitsumicro.com/>

### **Europe**

FUJITSU MIKROELEKTRONIK GmbH  
Am Siebenstein 6-10  
D-63303 Dreieich-Buchsschlag  
Germany  
Tel: (06103) 690-0  
Fax: (06103) 690-122

<http://www.fujitsu-edc.com/>

### **Asia Pacific**

FUJITSU MICROELECTRONICS ASIA PTE LTD  
#05-08, 151 Lorong Chuan  
New Tech Park  
Singapore 556741  
Tel: (65) 281-0770  
Fax: (65) 281-0220

<http://www.fmap.com.sg/>

F9904

© FUJITSU LIMITED Printed in Japan

All Rights Reserved.

The contents of this document are subject to change without notice. Customers are advised to consult with FUJITSU sales representatives before ordering.

The information and circuit diagrams in this document are presented as examples of semiconductor device applications, and are not intended to be incorporated in devices for actual use. Also, FUJITSU is unable to assume responsibility for infringement of any patent rights or other rights of third parties arising from the use of this information or circuit diagrams.

FUJITSU semiconductor devices are intended for use in standard applications (computers, office automation and other office equipment, industrial, communications, and measurement equipment, personal or household devices, etc.).

#### **CAUTION:**

Customers considering the use of our products in special applications where failure or abnormal operation may directly affect human lives or cause physical injury or property damage, or where extremely high levels of reliability are demanded (such as aerospace systems, atomic energy controls, sea floor repeaters, vehicle operating controls, medical devices for life support, etc.) are requested to consult with FUJITSU sales representatives before such use. The company will not be responsible for damages arising from such use without prior approval.

Any semiconductor devices have an inherent chance of failure. You must protect against injury, damage or loss from such failures by incorporating safety design measures into your facility and equipment such as redundancy, fire protection, and prevention of over-current levels and other abnormal operating conditions.

If any products described in this document represent goods or technologies subject to certain restrictions on export under the Foreign Exchange and Foreign Trade Law of Japan, the prior authorization by Japanese government will be required for export of those products from Japan.