

# ASSP For Power Management Applications

BIPOLAR

## Switching Regulator Controller (Switchable between push-pull and single-end functions)

# MB3759

### DESCRIPTION

The MB3759 is a control IC for constant-frequency pulse width modulated switching regulators. The IC contains most of the functions required for switching regulator control circuits. This reduces both the component count and assembly work.

### FEATURES

- Drives a 200 mA load
- Can be set to push-pull or single-end operation
- Prevents double pulses
- Adjustable dead-time
- Error amplifier has wide common phase input range
- Built in a circuit to prevent misoperation due to low power supply voltage.
- Built in an internal 5 V reference voltage with superior voltage reduction characteristics

### PACKAGES

16-pin plastic DIP

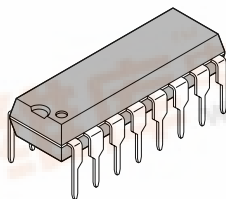

(DIP-16P-M04)

16-pin ceramic DIP

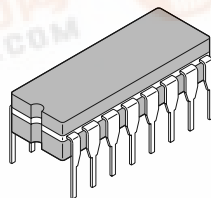

(DIP-16C-C01)

16-pin plastic SOP

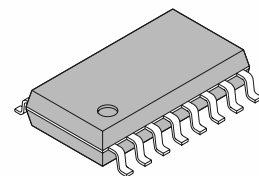

(FPT-16P-M06)

# MB3759

## ■ PIN ASSIGNMENT

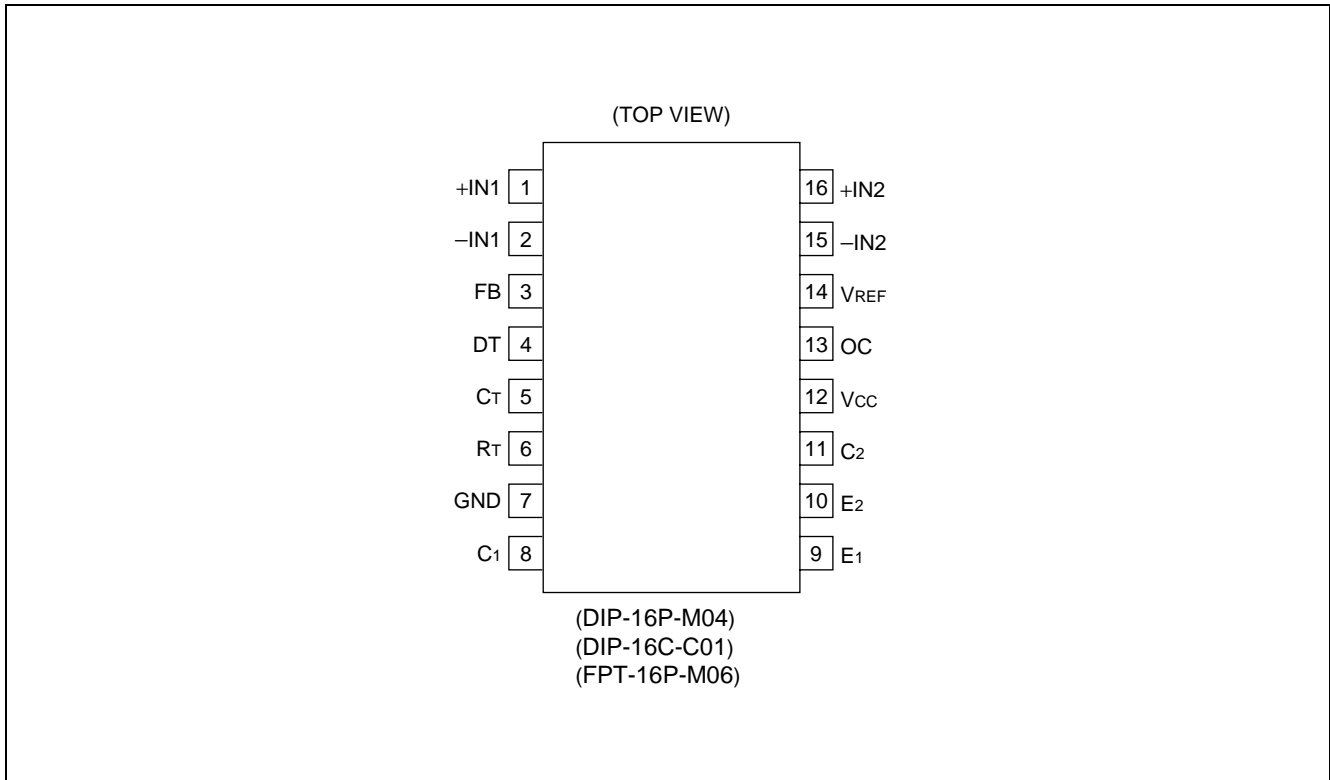

## ■ BLOCK DIAGRAM

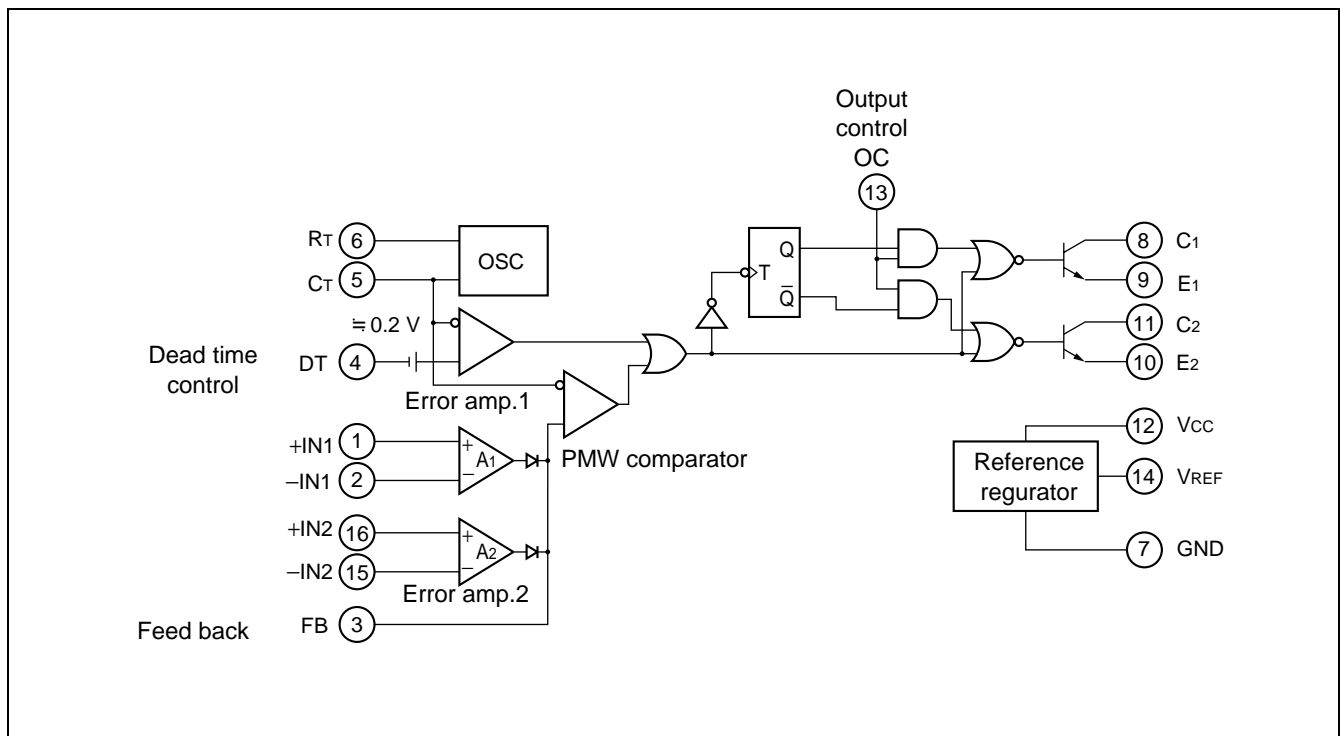

## ■ ABSOLUTE MAXIMUM RATINGS

Parameter	Symbol	Condition	Rating		Unit	
			Min	Max		
Power supply voltage	$V_{CC}$	—	—	41	V	
Collector output voltage	$V_{CE}$	—	—	41	V	
Collector output current	$I_{CE}$	—	—	250	mA	
Amplifier input voltage	$V_I$	—	—	$V_{CC} + 0.3$	V	
Power dissipation	Plastic DIP	$P_D$	$T_a \leq +25\text{ °C}$	—	1000	mW
	Ceramic DIP		$T_a \leq +60\text{ °C}$	—	800	
	SOP *		$T_a \leq +25\text{ °C}$	—	620	
Operating temperature	$T_{op}$	—	−30	+85	°C	
Storage temperature	$T_{stg}$	—	−55	+125	°C	

\*: When mounted on a 4 cm square double-sided epoxy circuit board (1.5 mm thickness)  
The ceramic circuit board is 3 cm x 4 cm (0.5 mm thickness)

WARNING: Semiconductor devices can be permanently damaged by application of stress (voltage, current, temperature, etc.) in excess of absolute maximum ratings. Do not exceed these ratings.

## ■ RECOMMENDED OPERATING CONDITIONS

Parameter	Symbol	Value			Unit
		Min	Typ	Max	
Power supply voltage	$V_{CC}$	7	15	32	V
Collector output voltage	$V_{CE}$	—	—	40	V
Collector output current	$I_{CE}$	5	—	200	mA
Amplifier input voltage	$V_{IN}$	−0.3	0 to $V_R$	$V_{CC} - 2$	V
FB sink current	$I_{SINK}$	—	—	0.3	mA
FB source current	$I_{SOURCE}$	—	—	2	mA
Reference section output current	$I_{REF}$	—	5	10	mA
Timing resistor	$R_T$	1.8	30	500	k $\Omega$
Timing capacitor	$C_T$	470	1000	$10^6$	pF
Oscillator frequency	$f_{osc}$	1	40	300	kHz
Operating temperature	$T_{op}$	−30	+25	+85	°C

Note: Values are for standard derating conditions. Give consideration to the ambient temperature and power consumption if using a high supply voltage.

WARNING: The recommended operating conditions are required in order to ensure the normal operation of the semiconductor device. All of the device's electrical characteristics are warranted when the device is operated within these ranges.

Always use semiconductor devices within their recommended operating condition ranges. Operation outside these ranges may adversely affect reliability and could result in device failure.

No warranty is made with respect to uses, operating conditions, or combinations not represented on the data sheet. Users considering application outside the listed conditions are advised to contact their FUJITSU representatives beforehand.

# MB3759

## ■ ELECTRICAL CHARACTERISTICS

( $V_{CC} = 15\text{ V}$ ,  $T_a = +25\text{ °C}$ )

Parameter		Symbol	Condition	Value			Unit	
				Min	Typ	Max		
Reference section	Output voltage	$V_{REF}$	$I_o = 1\text{ mA}$	4.75	5.0	5.25	V	
	Input regulation	$\Delta V_{R(IN)}$	$7\text{ V} \leq V_{CC} \leq 40\text{ V}$ , $T_a = +25\text{ °C}$	—	2	25	mV	
	Load regulation	$\Delta V_{R(LD)}$	$1\text{ mA} \leq I_o \leq 10\text{ mA}$ , $T_a = +25\text{ °C}$	—	-1	-15	mV	
	Temperature stability	$\Delta V_R/\Delta T$	$-20\text{ °C} \leq T_a \leq +85\text{ °C}$	—	$\pm 200$	$\pm 750$	$\mu\text{V}/\text{°C}$	
	Short circuit output current	$I_{SC}$	—	15	40	—	mA	
	Reference lockout voltage	—	—	—	4.3	—	V	
	Reference hysteresis voltage	—	—	—	0.3	—	V	
Oscillator section	Oscillator frequency	$f_{OSC}$	$R_T = 30\text{ k}\Omega$ , $C_T = 1000\text{ pF}$	36	40	44	kHz	
	Standard deviation of frequency	—	$R_T = 30\text{ k}\Omega$ , $C_T = 1000\text{ pF}$	—	$\pm 3$	—	%	
	Frequency change with voltage	—	$7\text{ V} \leq V_{CC} \leq 40\text{ V}$ , $T_a = +25\text{ °C}$	—	$\pm 0.1$	—	%	
	Frequency change with temperature	$\Delta f_{OSC}/\Delta T$	$-20\text{ °C} \leq T_a \leq +85\text{ °C}$	—	$\pm 0.01$	$\pm 0.03$	$\%/^{\circ}\text{C}$	
Dead-time control section	Input bias current	$I_D$	$0 \leq V_i \leq 5.25\text{ V}$	—	-2	-10	$\mu\text{A}$	
	Maximum duty cycle (Each output)	—	$V_i = 0$	40	45	—	%	
	Input threshold voltage	0% duty cycle	$V_{DO}$	—	—	3.0	3.3	V
		Max. duty cycle	$V_{DM}$	—	0	—	—	V

(Continued)

(Continued)

( $V_{CC} = 15\text{ V}$ ,  $T_a = +25\text{ }^\circ\text{C}$ )

Parameter		Symbol	Condition	Value			Unit	
				Min	Typ	Max		
Error amplifier section	Input offset voltage		$V_{IO}$	$V_{O(\text{pin}3)} = 2.5\text{ V}$	—	$\pm 2$	$\pm 10$	mV
	Input offset current		$I_{IO}$	$V_{O(\text{pin}3)} = 2.5\text{ V}$	—	$\pm 25$	$\pm 250$	nA
	Input bias current		$I_I$	$V_{O(\text{pin}3)} = 2.5\text{ V}$	—	-0.2	-1.0	$\mu\text{A}$
	Common-mode input voltage		$V_{CM}$	$7\text{ V} \leq V_{CC} \leq 40\text{ V}$	-0.3	—	$V_{CC} - 2$	V
	Open-loop voltage amplification		$A_V$	$0.5\text{ V} \leq V_O \leq 3.5\text{ V}$	70	95	—	dB
	Unity-gain bandwidth		BW	$A_V = 1$	—	800	—	kHz
	Common-mode rejection ratio		CMR	$V_{CC} = 40\text{ V}$	65	80	—	dB
	Output sink current (pin 3)	ISINK	$I_{SINK}$	$-5\text{ V} \leq V_{ID} \leq -15\text{ mV}$ , $V_O = 0.7\text{ V}$	0.3	0.7	—	mA
ISOURCE		$I_{SOURCE}$	$15\text{ mV} \leq V_{ID} \leq 5\text{ V}$ , $V_O = 3.5\text{ V}$	-2	-10	—	mA	
Output section	Collector leakage current		$I_{CO}$	$V_{CE} = 40\text{ V}$ , $V_{CC} = 40\text{ V}$	—	—	100	$\mu\text{A}$
	Emitter leakage current		$I_{EO}$	$V_{CC} = V_C = 40\text{ V}$ , $V_E = 0$	—	—	-100	$\mu\text{A}$
	Collector emitter saturation voltage	Emitter grounded	$V_{SAT(C)}$	$V_E = 0$ , $I_C = 200\text{ mA}$	—	1.1	1.3	V
		Emitter follower	$V_{SAT(E)}$	$V_C = 15\text{ V}$ , $I_E = -200\text{ mA}$	—	1.5	2.5	V
	Output control input current		$I_{OPC}$	$V_I = V_{REF}$	—	1.3	3.5	mA
PWM comparator section	Input threshold voltage		$V_{TH}$	0% Duty	—	4	4.5	V
	Input sink current (pin 3)		$I_{SINK}$	$V_{O(\text{pin}3)} = 0.7\text{ V}$	0.3	0.7	—	mA
Power supply current		$I_{CC}$	$V_{(\text{pin}4)} = 2\text{ V}$ , See Fig-2	—	8	—	mA	
Standby current		$I_{CCQ}$	$V_{(\text{pin}6)} = V_{REF}$ , I/O open	—	7	12	mA	
Switching characteristics	Rise time	Emitter grounded	$t_R$	$R_L = 68\ \Omega$	—	100	200	ns
	Fall time		$t_F$	$R_L = 68\ \Omega$	—	25	100	ns
	Rise time	Emitter follower	$t_R$	$R_L = 68\ \Omega$	—	100	200	ns
	Fall time		$t_F$	$R_L = 68\ \Omega$	—	40	100	ns

# MB3759

## TEST CIRCUIT

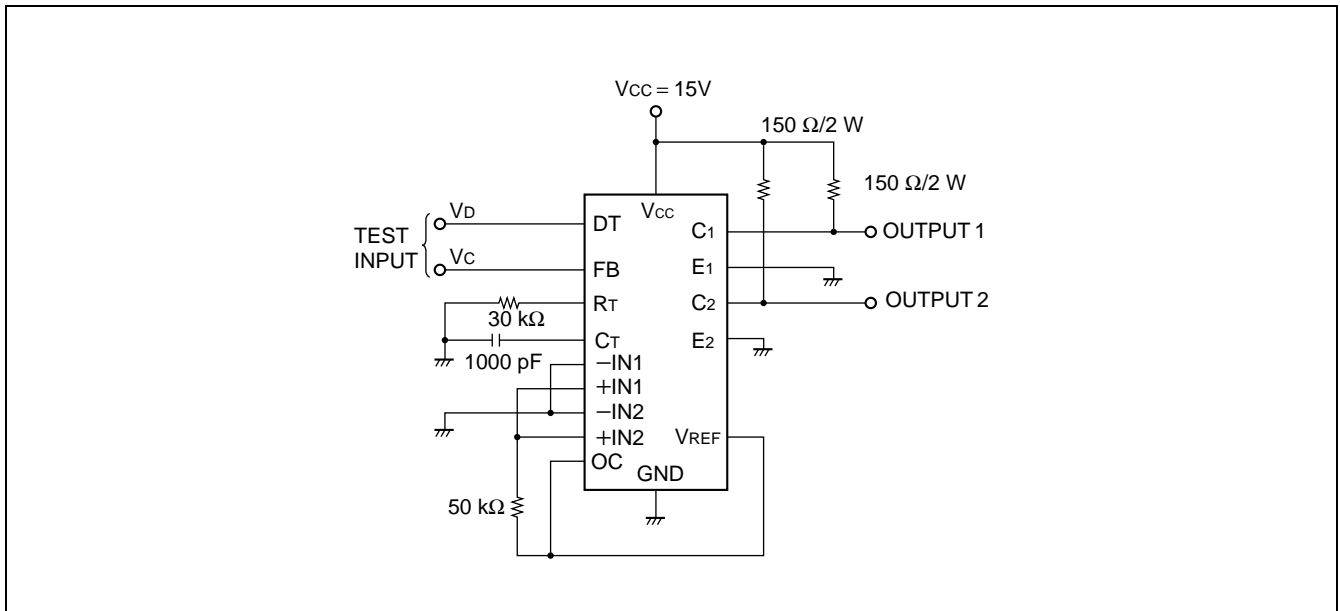

## OPERATING TIMING

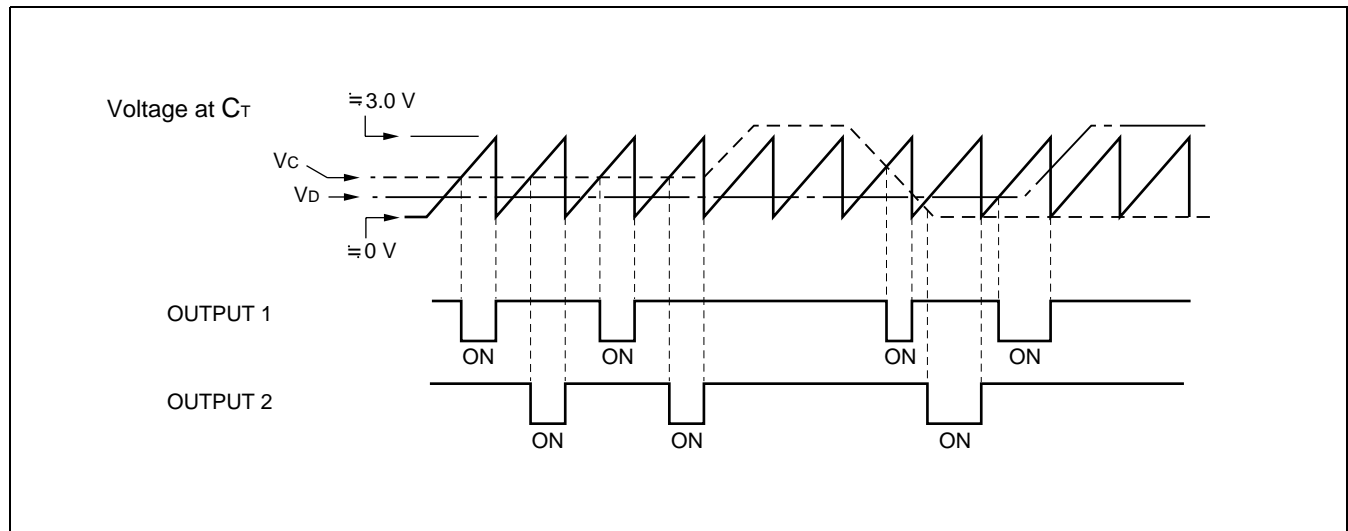

## ■ OSCILLATION FREQUENCY

$$f_{OSC} = \frac{1.2}{R_T \cdot C_T}$$

$R_T$  : k $\Omega$   
 $C_T$  :  $\mu$ F  
 $f_{osc}$  : kHz

## ■ OUTPUT LOGIC TABLE

Input (Output Control)	Output State
GND	Single-ended or parallel output
V <sub>REF</sub>	Push-pull

# MB3759

## ■ TYPICAL CHARACTERISTICS

Reference voltage vs. power supply voltage

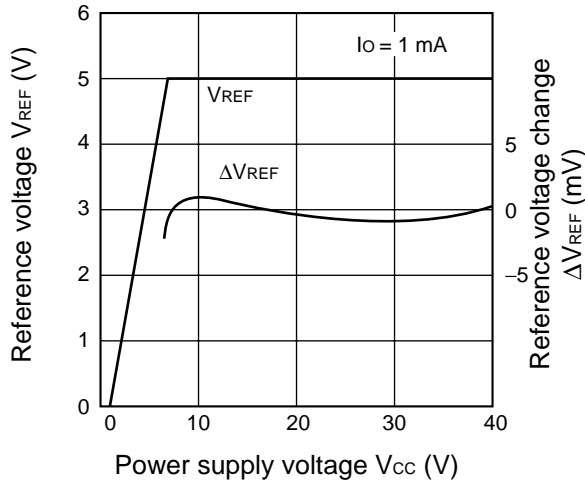

Reference voltages. temperature

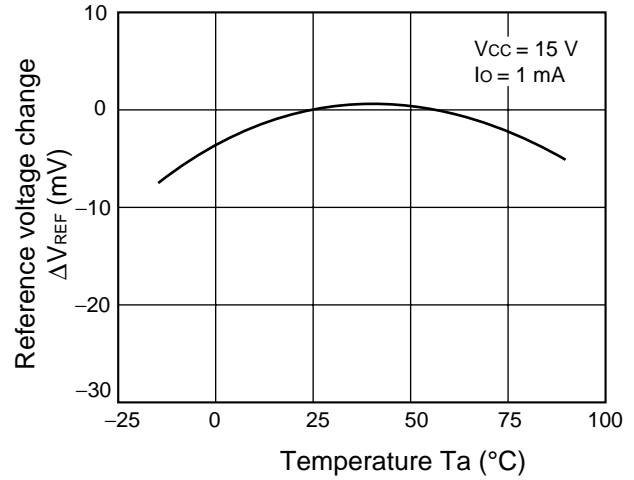

Oscillator vs.  $R_T$ ,  $C_T$

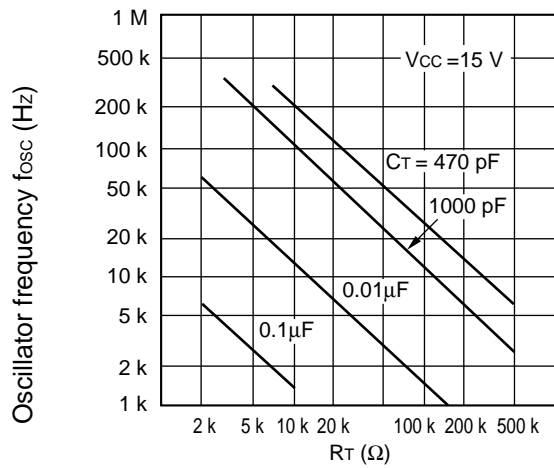

Duty ratio vs. dead time control voltage

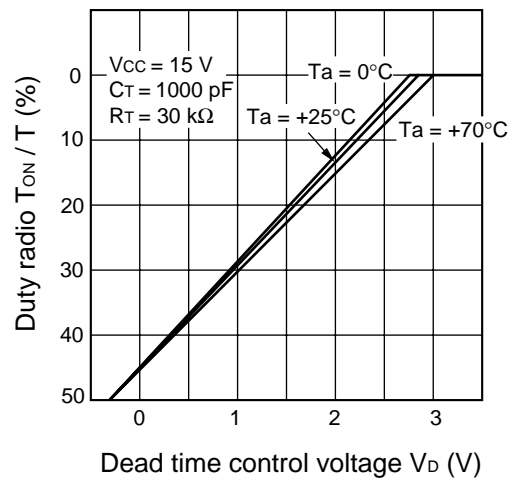

(Continued)



Open loop voltage amplification vs. frequency

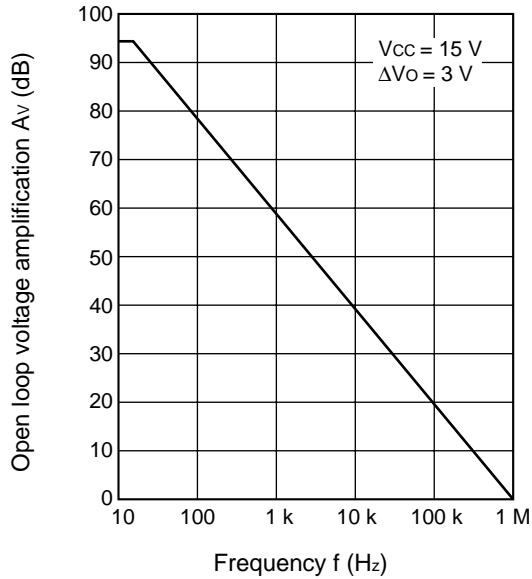

Output voltage vs. output current (feed back terminal)

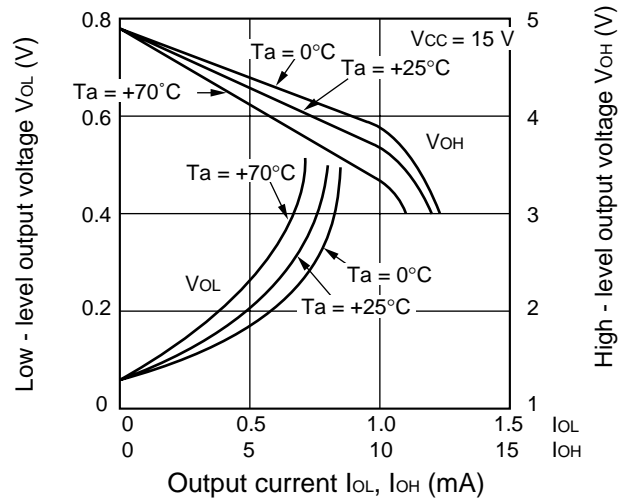

Collector saturation voltage vs. collector output current

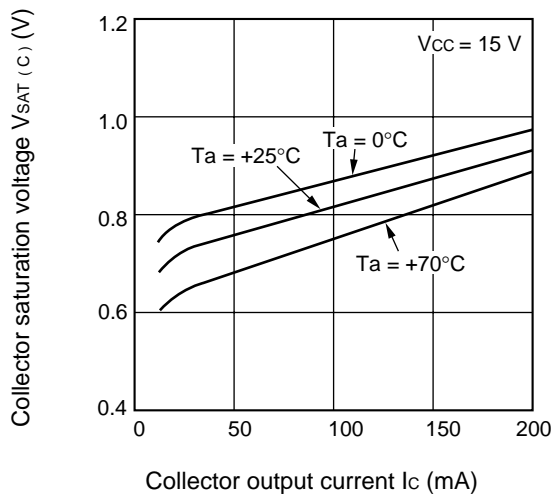

Emitter saturation voltage vs. emitter output current

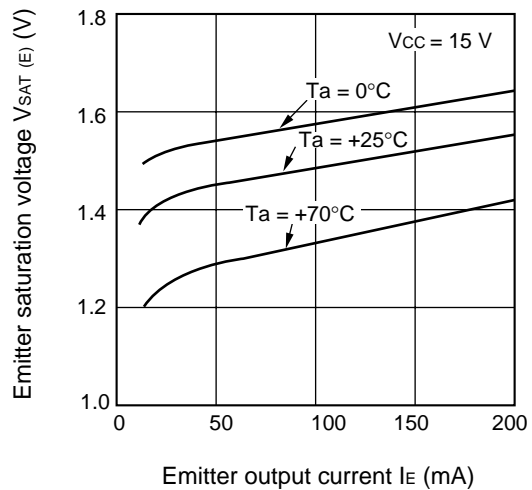

# MB3759

(Continued)

Output voltage vs. reference voltage

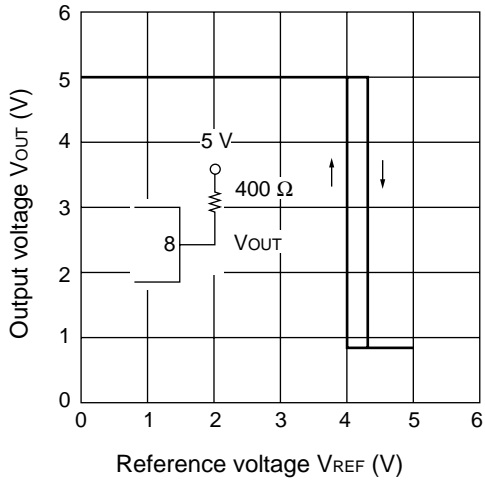

Power supply current vs. power supply voltage

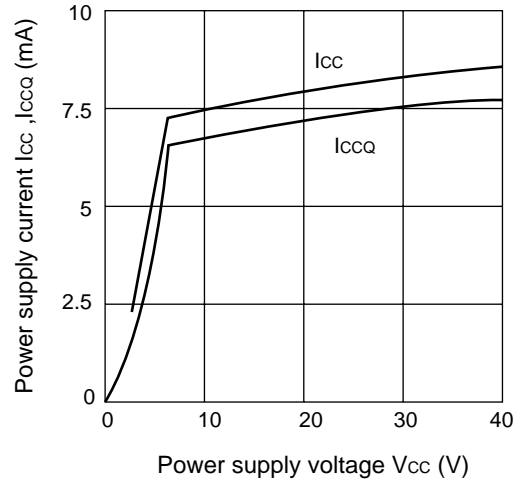

Power dissipation vs. power supply voltage

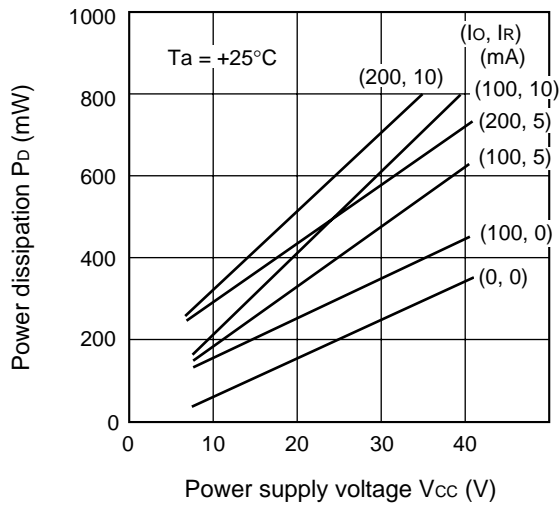

Power dissipation vs. ambient temperature

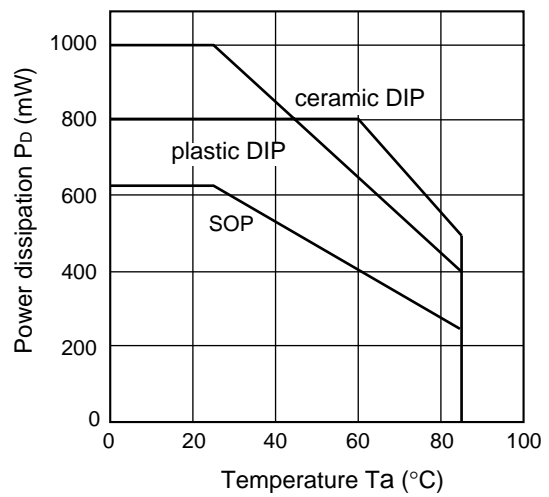

## ■ BASIC OPERATION

Switching regulators can achieve a high level of efficiency. This section describes the basic principles of operation using a chopper regulator as an example.

As shown in the diagram, diode D provides a current path for the current through inductance L when Q is off. Transistor Q performs switching and is operated at a frequency that provides a stable output. As the switching element is saturated when Q is on and cutoff when Q is off, the losses in the switching element are much less than for a series regulator in which the pass transistor is always in the active state.

While Q is conducting, the input voltage  $V_{IN}$  is supplied to the LC circuit and when Q is off, the energy stored in L is supplied to the load via diode D. The LC circuit smooths the input to supply the output voltage.

The output voltage  $V_o$  is given by the following equation.

$$V_o = \frac{T_{on}}{T_{on} + T_{off}} V_{IN} = \frac{T_{on}}{T} V_{IN}$$

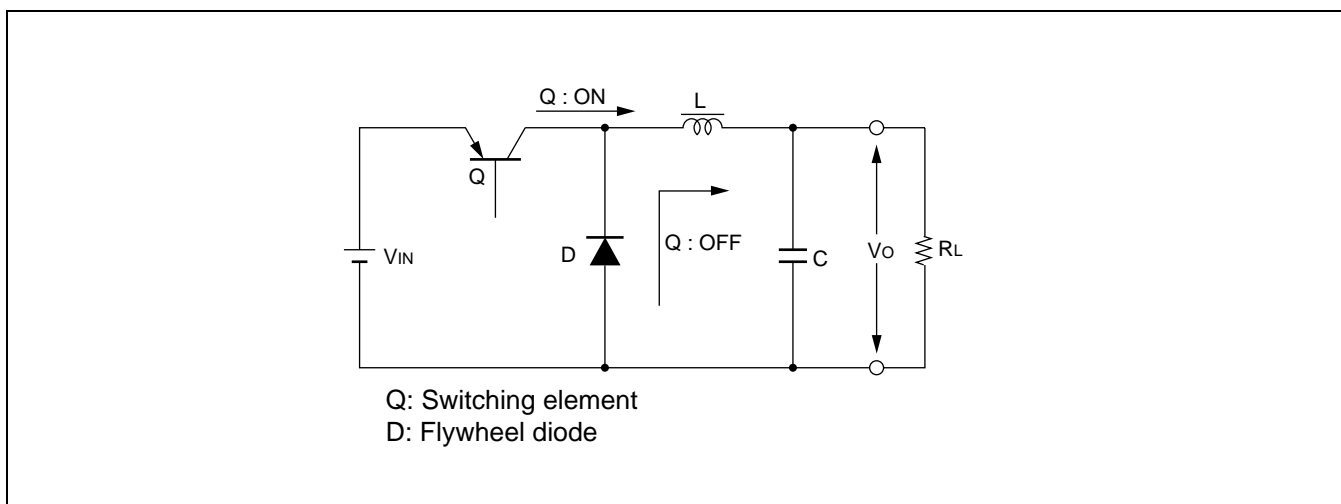

As indicated by the equation, variation in the input voltage is compensated for by controlling the duty cycle ( $T_{on}/T$ ). If  $V_{IN}$  drops, the control circuit operates to increase the duty cycle so as to keep the output voltage constant. The current through L flows from the input to the output when Q is on and through D when Q is off. Accordingly, the average input current  $I_{IN}$  is the product of the output current and the duty cycle for Q.

$$I_{IN} = \frac{T_{on}}{T} I_o$$

The theoretical conversion efficiency if the switching loss in Q and loss in D are ignored is as follows.

$$\begin{aligned} \eta &= \frac{P_o}{P_{IN}} \times 100 (\%) \\ &= \frac{V_o \cdot I_o}{V_{IN} \cdot I_{IN}} \times 100 \\ &= \frac{V_{IN} \cdot I_o \cdot T_{on} / T}{V_{IN} \cdot I_o \cdot T_{on} / T} \times 100 \\ &= 100 (\%) \end{aligned}$$

The theoretical conversion efficiency is 100%. In practice, losses occur in the switching element and elsewhere, and design decisions to minimize these losses include making the switching frequency as low as practical and setting an optimum ratio of input to output voltage.

# MB3759

## ■ SWITCHING ELEMENT

### 1. Selection of the Switching Transistor

It can be said that the success or otherwise of a switching regulator is determined by the choice of switching transistor. Typically, the following parameters are considered in selecting a transistor.

- Withstand voltage
- Current
- Power
- Speed

For the withstand voltage, current, and power, it is necessary to determine that the area of safe operation (ASO) of the intended transistor covers the intended range for these parameters.

The speed (switching speed: rise time  $t_r$ , storage time  $t_{stg}$ , and fall time  $t_f$ ) is related to the efficiency and also influences the power.

The figures show the transistor load curve and  $V_{CE} - I_c$  waveforms for chopper and inverter-type regulators.

The chopper regulator is a relatively easy circuit to deal with as the diode clamps the collector. A peak can be seen immediately after turn-on. However, this is due to the diode and is explained later.

In an inverter regulator, the diodes on the secondary side act as a clamp. Viewed from the primary side, however, a leakage inductance is present. This results in an inductive spike which must be taken account of as it is added to double the  $V_{IN}$  voltage.

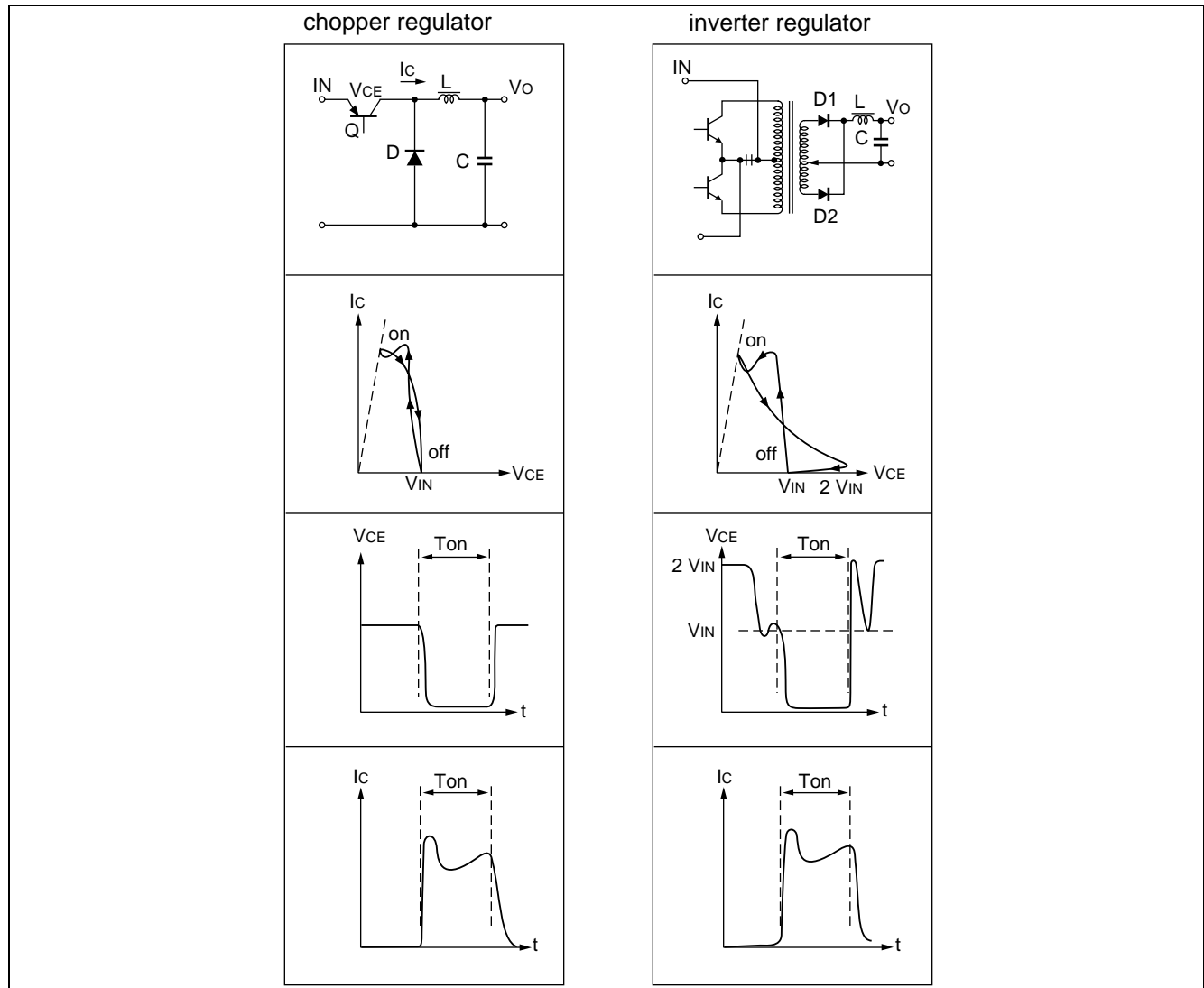

The figure below shows an example of the ASO characteristics for a forward-biased power transistor (2SC3058A) suitable for switching.

Check that the ASO characteristics for the transistor you intend to use fully covers the load curve. Next, check whether the following conditions are satisfied. If so, the transistor can be expected to perform the switching operation safely.

- The intended ON time does not exceed the ON-time specified for the ASO characteristic.
- The OFF-time ASO characteristic satisfies the intended operation conditions.
- Derating for the junction temperature has been taken into account.

For a switching transistor, the junction temperature is closely related to the switching speed. This is because the switching speed becomes slower as the temperature increases and this affects the switching losses.

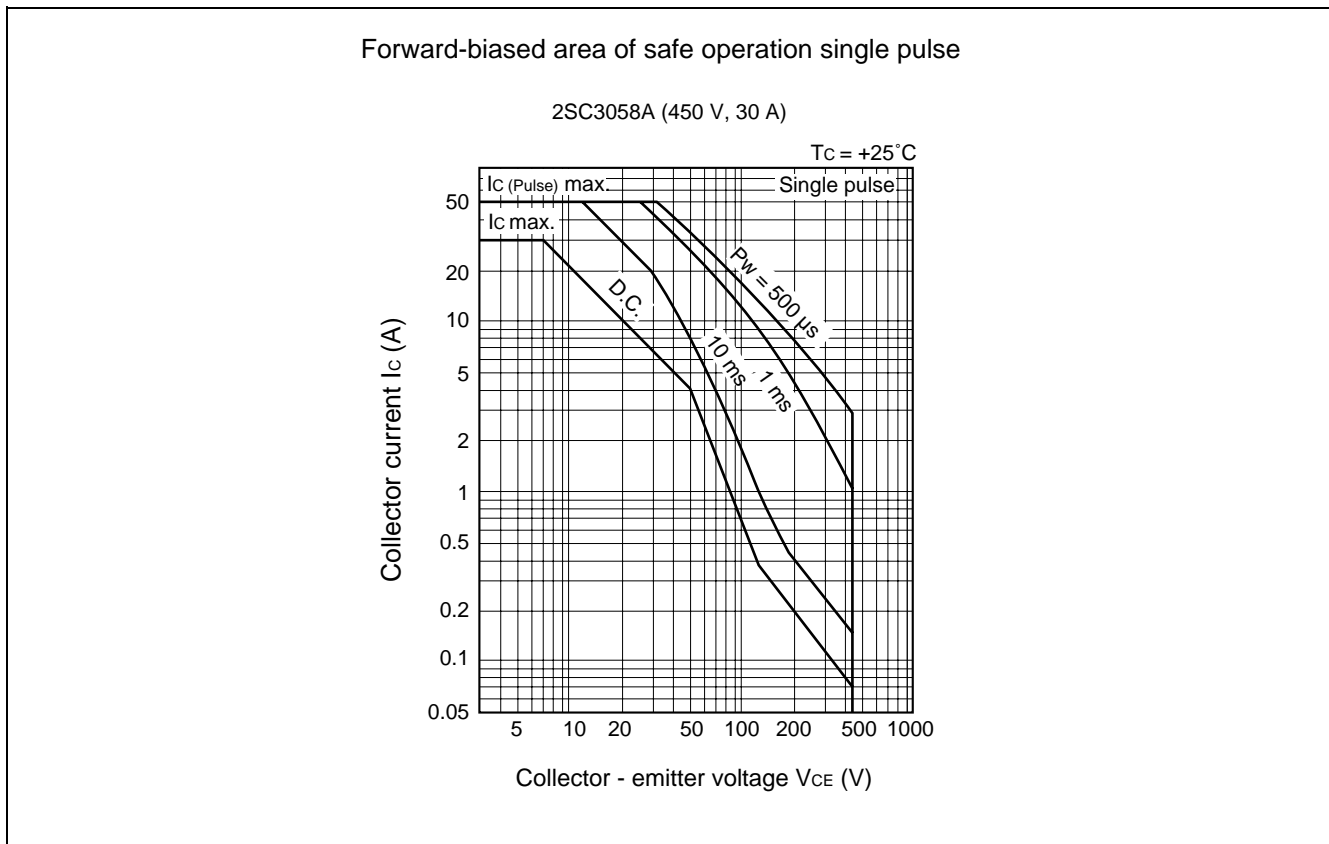

## 2. Selecting the Diode

Consideration must be given to the switching speed when selecting the diode. For chopper regulators in particular, the diode affects the efficiency and noise characteristics and has a big influence on the performance of the switching regulator.

If the reverse recovery time of the diode is slower than the turn-on time of the transistor, an in-rush current of more than twice the load current occurs resulting in noise (spikes) and reduced efficiency.

As a rule for diode selection, use a diode with a reverse recovery time  $t_{rr}$  that is sufficiently faster than the transistor  $t_r$ .

# MB3759

## ■ APPLICATION IN PRACTICAL CIRCUITS

### 1. Error Amplifier Gain Adjustment

Take care that the bias current does not become large when connecting an external circuit to the FB pin (pin 3) for adjusting the amplifier gain. As the FB pin is biased to the low level by a sink current, the duty cycle of the output signal will be affected if the current from the external circuit is greater than the amplifier can sink.

The figure below shows a suitable circuit for adjusting the gain.

It is very important that you avoid having a capacitive load connected to the output stage as this will affect the response time.

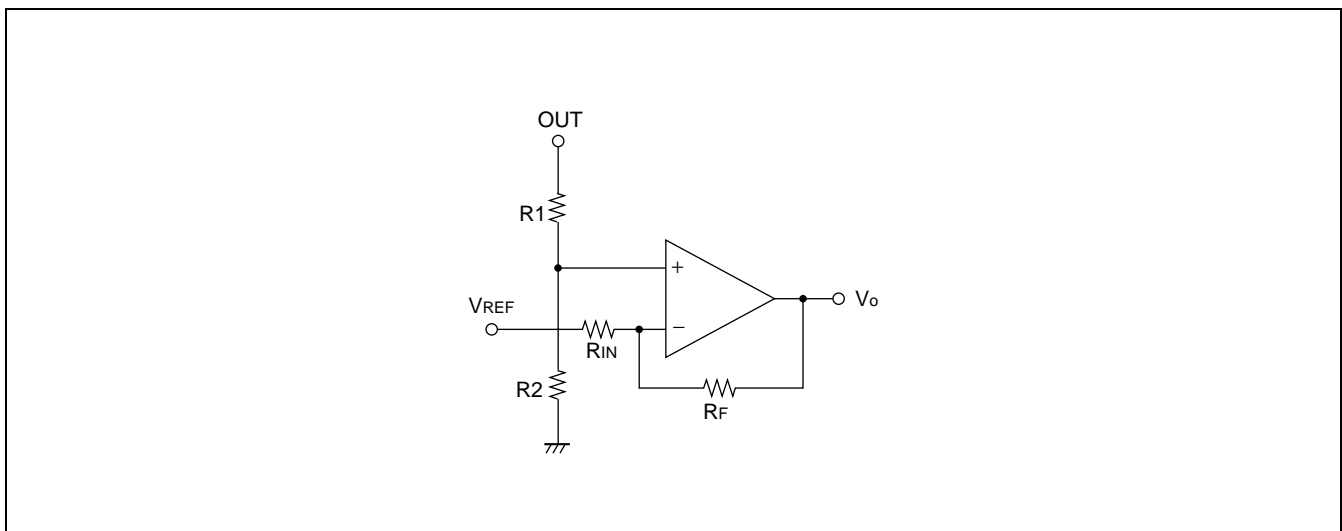

### 2. Synchronized Oscillator Operation

The oscillator can be halted by connecting the  $C_T$  pin to the GND pin. If supplying the signal externally, halt the internal oscillator and input to the  $C_T$  pin.

Using this method, multiple ICs can be used together in synchronized operation. For synchronized operation, set one IC as the master and connect the other ICs as shown in the diagram.

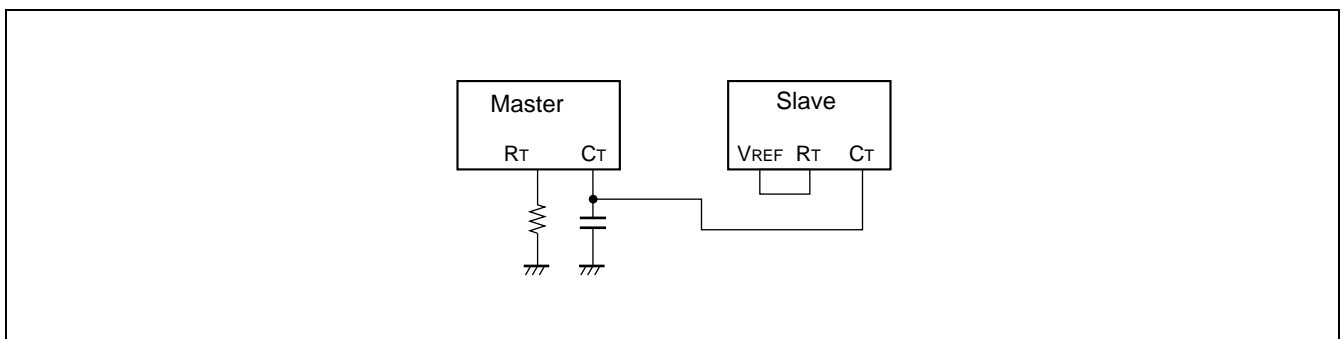

### 3. Soft Start

A soft start function can be incorporated by using the dead-time control element.

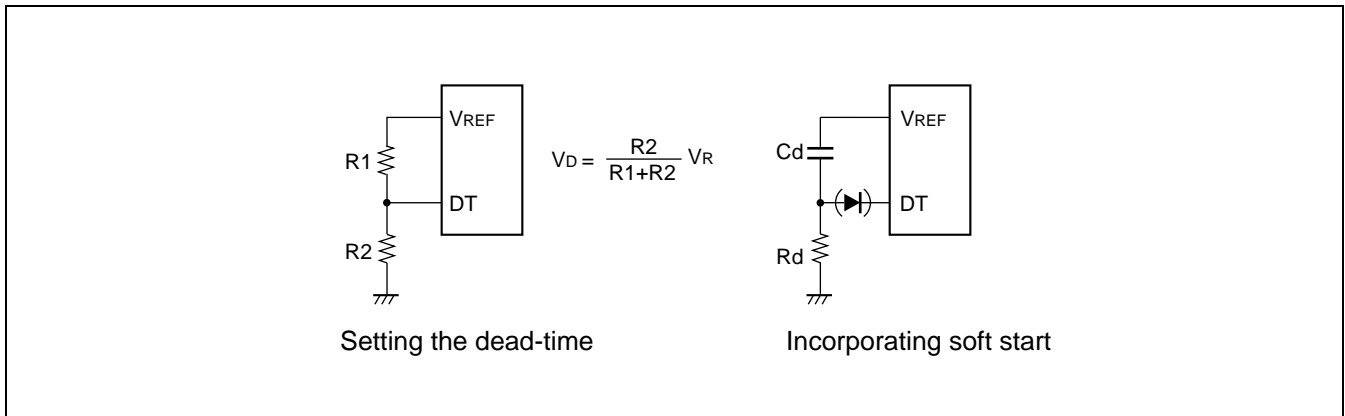

When the power is turned on, Cd is not yet charged and the DT input is pulled to the V<sub>REF</sub> pin causing the output transistor to turn off. Next, the input voltage to the DT pin drops in accordance with the Cd, Rd constant causing the output pulse width to increase steadily, providing stable control circuit operation. If you wish to use both dead-time and softstart, combine these in an OR configuration.

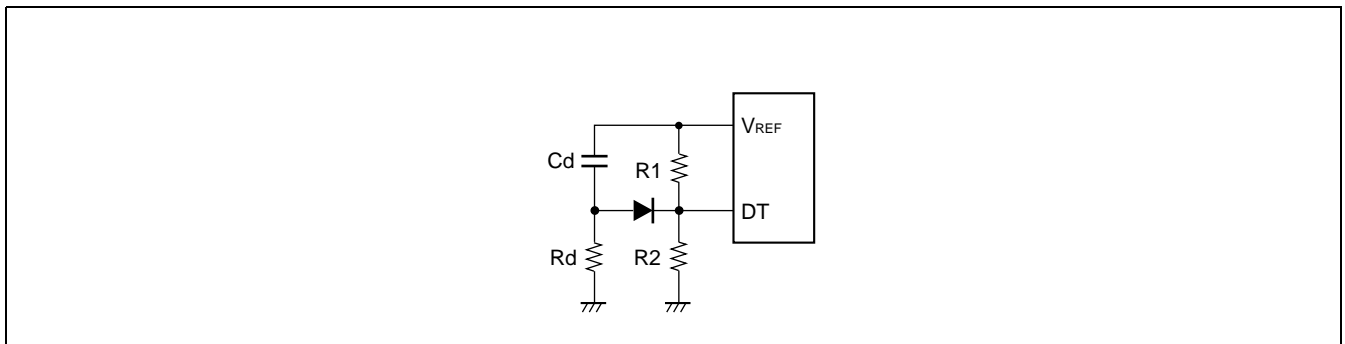

### 4. Output Current Limiting (Fallback system using a detection resistor inserted on the output side)

#### (1) Typical example

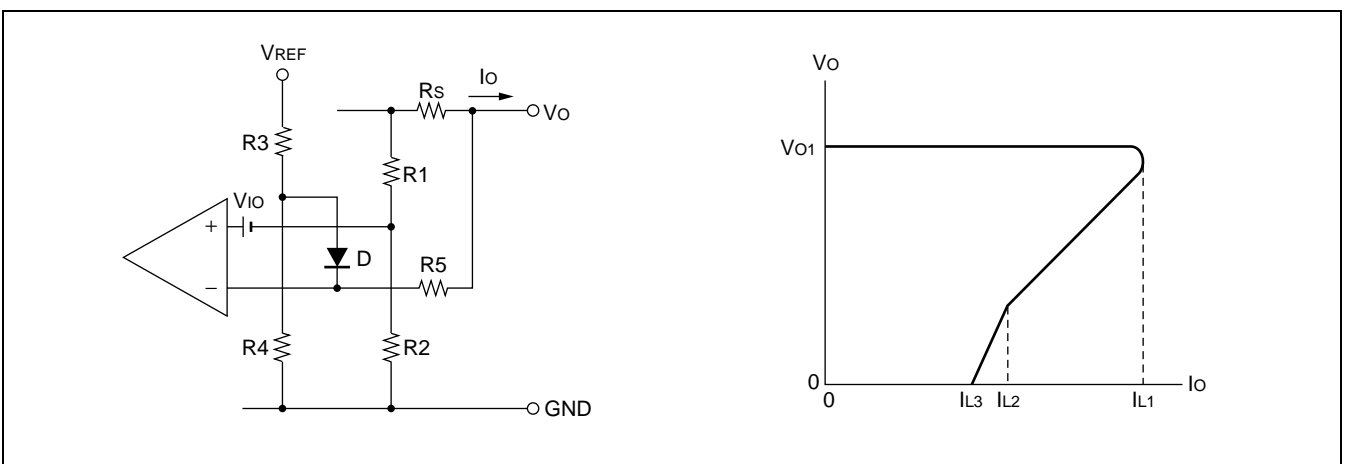

# MB3759

- Initial limit current  $I_{L1}$

$$V_O > \frac{R_4}{R_3 + R_4} V_{REF} \quad \text{The condition for } V_O \text{ is:}$$

As the diode is reverse biased

$$R_s I_{L1} = \frac{R_1}{R_1 + R_2} V_O - V_{IO}$$

$$\therefore I_{L1} = \frac{R_1}{R_1 + R_2} \frac{V_O}{R_s} - \frac{V_{IO}}{R_s} \quad \text{Eq. (1) (where } R_2 \gg R_1 \text{)}$$

$V_{IO}$  is the input offset voltage to the op-amp ( $-10 \text{ mV} \leq V_{IO} \leq +10 \text{ mV}$ ) and this causes the variation in  $I_L$ . Accordingly, if for example the variation in  $I_L$  is to be limited to  $\pm 10\%$ , using equation (1) and only considering the variation in the offset voltage gives the following:

$$I_O = \frac{1}{R_s} \frac{R_1}{R_1 + R_2} (V_O + V_{EE}) - \frac{V_{IO}}{R_s} \quad (R_2 \gg R_1)$$

This indicates a setting of 100 mV or more is required.

- Polarity change point  $I_{L2}$

As this is the point where the diode becomes forward biased, it can be calculated by substituting  $[R_4/(R_3+R_4) V_{REF} - V_D]$  for  $V_O$  in equation (where  $V_D$  is the forward voltage of the diode).

$$I_{L2} = \frac{R_1}{R_1 + R_2} \frac{R_4 / (R_3 + R_4) \cdot V_{REF} - V_D}{R_s} - \frac{V_{IO}}{R_s}$$

- Final limit current  $I_{L3}$

The limit current for  $V_O = 0$  when  $R_2 \gg R_1$  is the point where the voltages on either side of  $R_s$  and on either side of  $R_5$  are biased.

$$R_s I_{L3} = \frac{R_4 R_5 V_{REF} - R_3 R_5 V_D - R_4 R_5 V_D}{R_3 R_4 + R_3 R_5 + R_4 R_5} - V_{IO}$$

$$\therefore I_{L3} = \frac{1}{R_s} \frac{1}{1 + (R_3 // R_4) / R_5} \left( \frac{R_4}{R_3 + R_4} V_{REF} - V_D \right) - \frac{V_{IO}}{R_s} \quad (2) \text{ Eq.}$$

$R_3 // R_4$  is the resistance formed by  $R_3$  and  $R_4$  in parallel ( $R_3 R_4 / (R_3 + R_4)$ ). When  $R_3 // R_4 \ll R_5$ , equation (2) becomes:

$$I_{L3 C} = \frac{1}{R_s} \left( \frac{R_4}{R_3 + R_4} V_{REF} - V_D \right) - \frac{V_{IO}}{R_s}$$

In addition to determining the limit current  $I_{L3}$  for  $V_O = 0$ ,  $R_3$ ,  $R_4$ ,  $R_5$ , and diode  $D$  also operate as a starter when the power is turned on.

- Starter circuit

The figure below shows the case when the starter circuit formed by  $R_3$ ,  $R_4$ ,  $R_5$ , and  $D$  is not present. The output current  $I_O$  after the operation of the current limiting circuit is:

$$I_O = \frac{R_1}{R_1 + R_2} \frac{V_O}{R_s} - \frac{V_{IO}}{R_s}$$

When  $V_O = 0$  such as when the power is turned on, the output current  $I_O = -V_{IO} / R_s$  and, if the offset voltage  $V_{IO}$  is positive, the output current is limited to being negative and therefore the output voltage does not rise. Accordingly, if using a fallback system with a detection resistor inserted in the output, always include a starter circuit, expect in the cases described later.



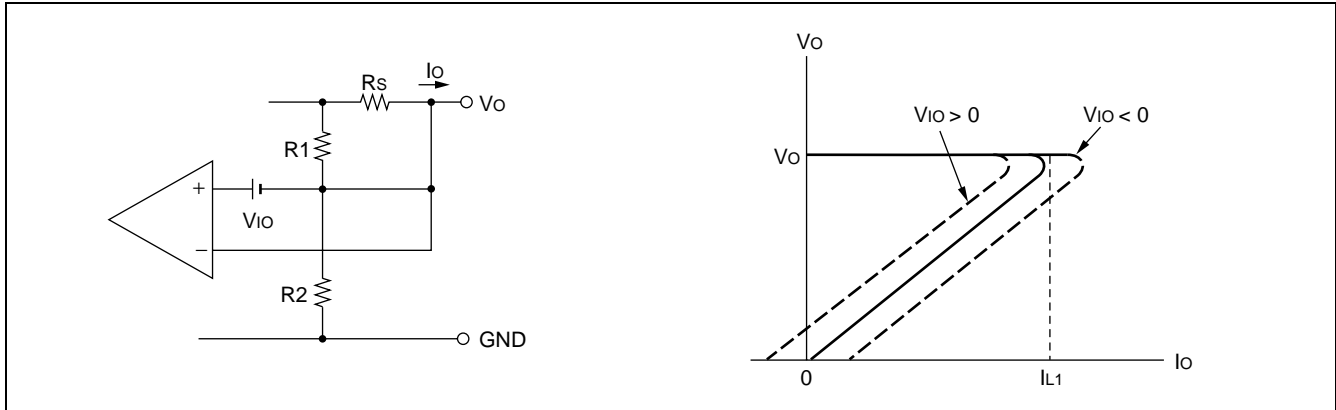

## (2) Example that does not use a diode

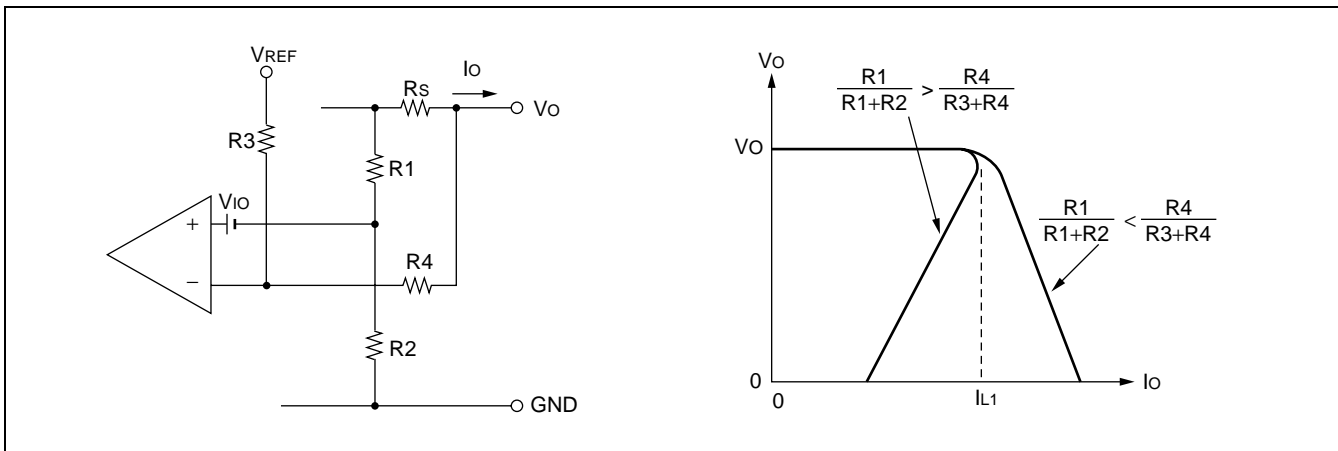

The output current  $I_o$  after current limiting is:

$$I_o = -\frac{1}{R_s} \left[ \left( \frac{R_1}{R_1+R_2} - \frac{R_4}{R_3+R_4} \right) V_o + \frac{R_4}{R_3+R_4} V_{REF} - V_{IO} \right] \quad (R_2 \gg R_1)$$

In this case, a current flows into the reference voltage source via R3 and R4 if  $V_o > V_{REF}$ . To maintain the stability of the reference voltage, design the circuit such that this does not exceed 200  $\mu$ A.

# MB3759

## (3) When an external stabilized negative power supply is present

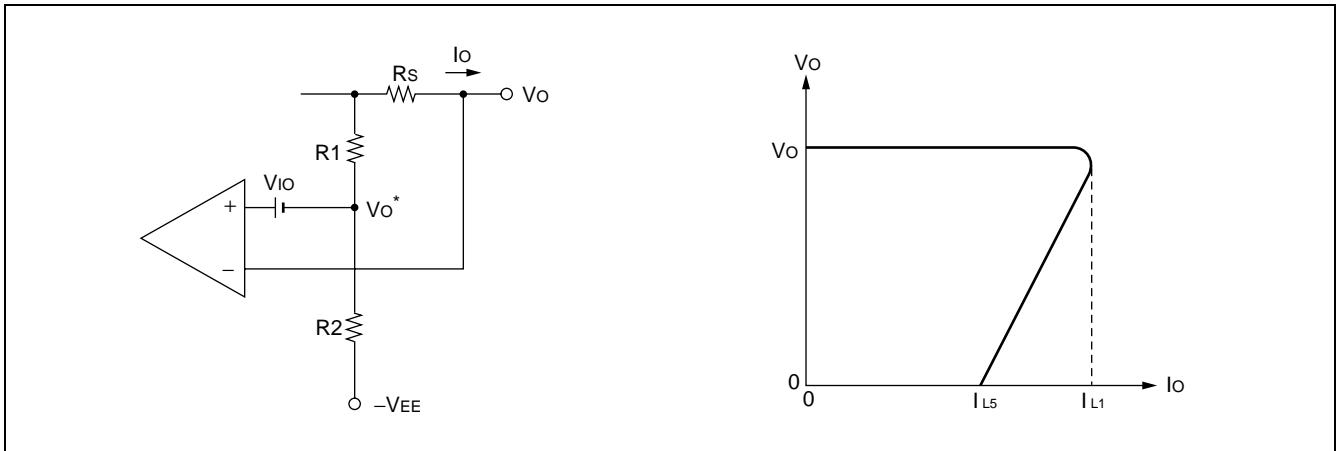

The output current  $I_O$  after current limiting is:

$$I_O = \frac{1}{R_S} \frac{R_1}{R_1 + R_2} (V_O + V_{EE}) - \frac{V_{IO}}{R_S} \quad (R_2 \gg R_1)$$

If the output is momentarily shorted,  $V_{O^*}$  goes briefly negative. In this case, set the voltage across  $R_1$  to 300 mV or less to ensure that a voltage of less than -0.3 V is not applied to the op-amp input.

## 5. Example Power Supply Voltage Supply Circuit

### (1) Supplied via a Zener diode

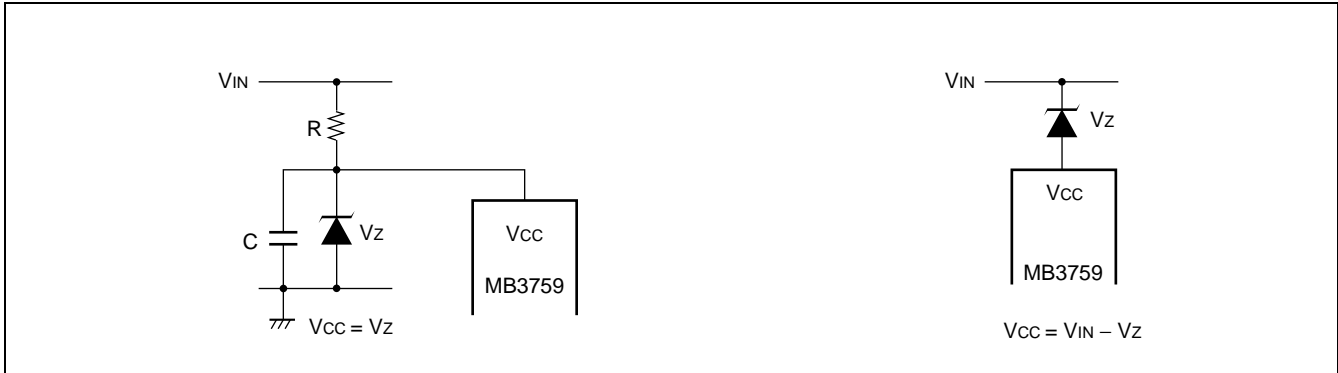

### (2) Supplied via a three-terminal regulator

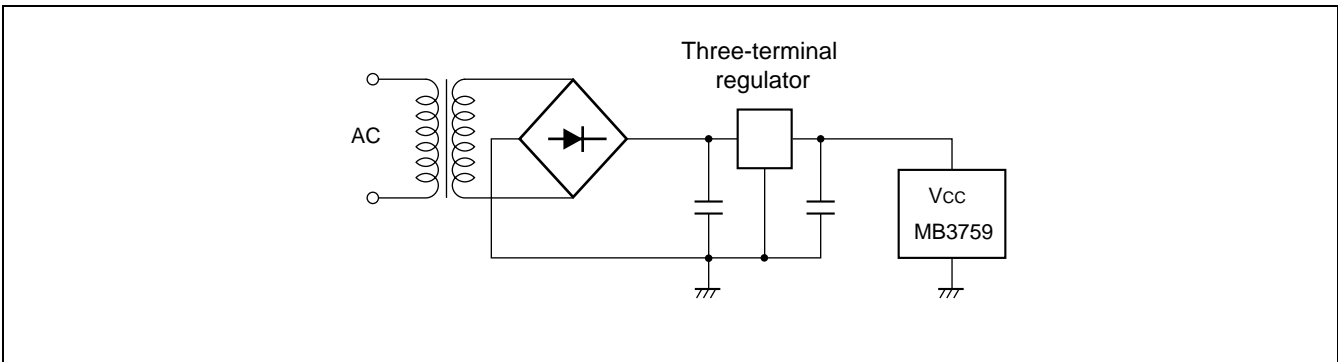

## 6. Example Protection Circuit for Output Transistor

Due to its monolithic IC characteristics, applying a negative voltage greater than the diode voltage ( $\approx 0.5\text{ V}$ ) to the substrate (pin 7) of the MB3759 causes a parasitic effect in the IC which can result in misoperation.

Accordingly, the following measures are required if driving a transformer or similar directly from the output transistor of the IC.

### (1) Protect the output transistor from the parasitic effect by using a Schottky barrier diode.

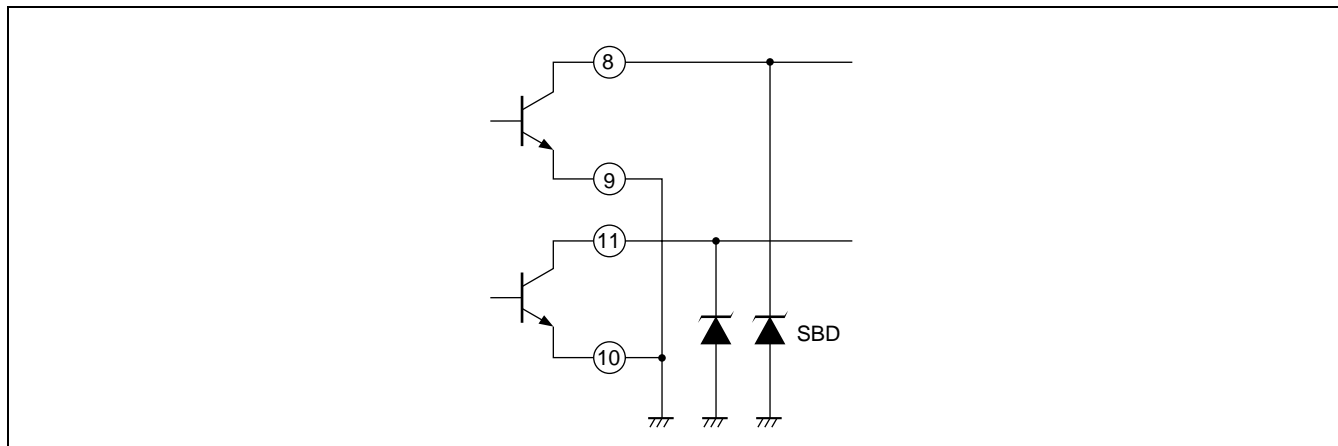

# MB3759

(2) Provide a bias at the anode-side of the diode to clamp the low level side of the transistor.

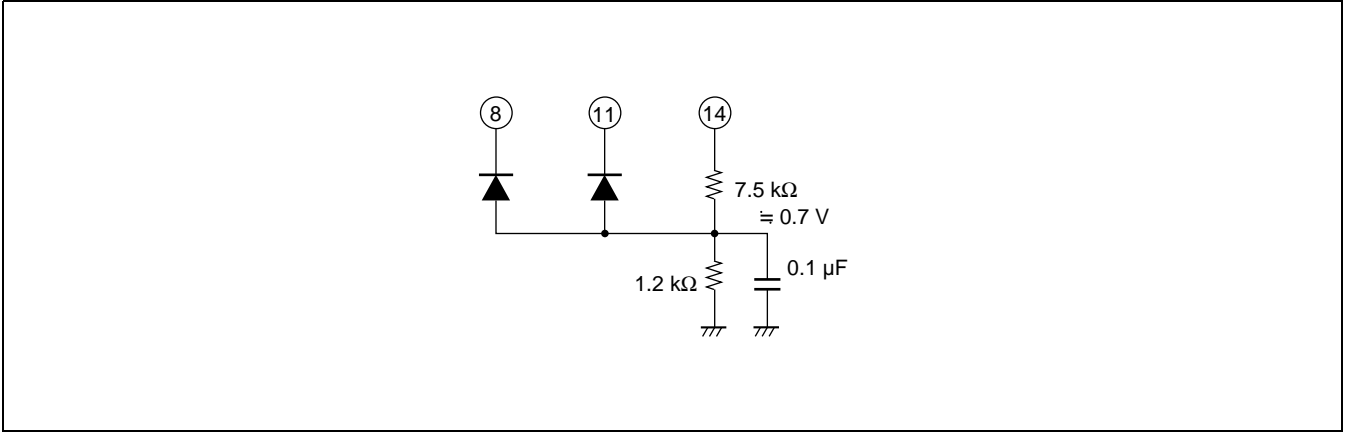

(3) Drive the transformer via a buffer transistor.

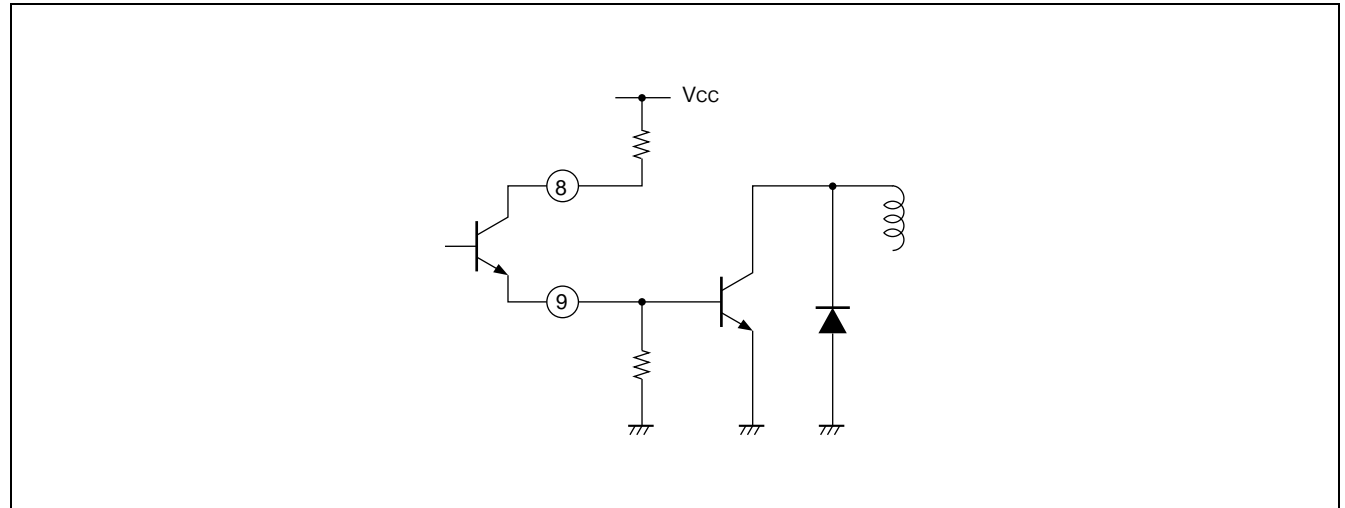

## 7. Typical Application

### (1) Chopper regulator

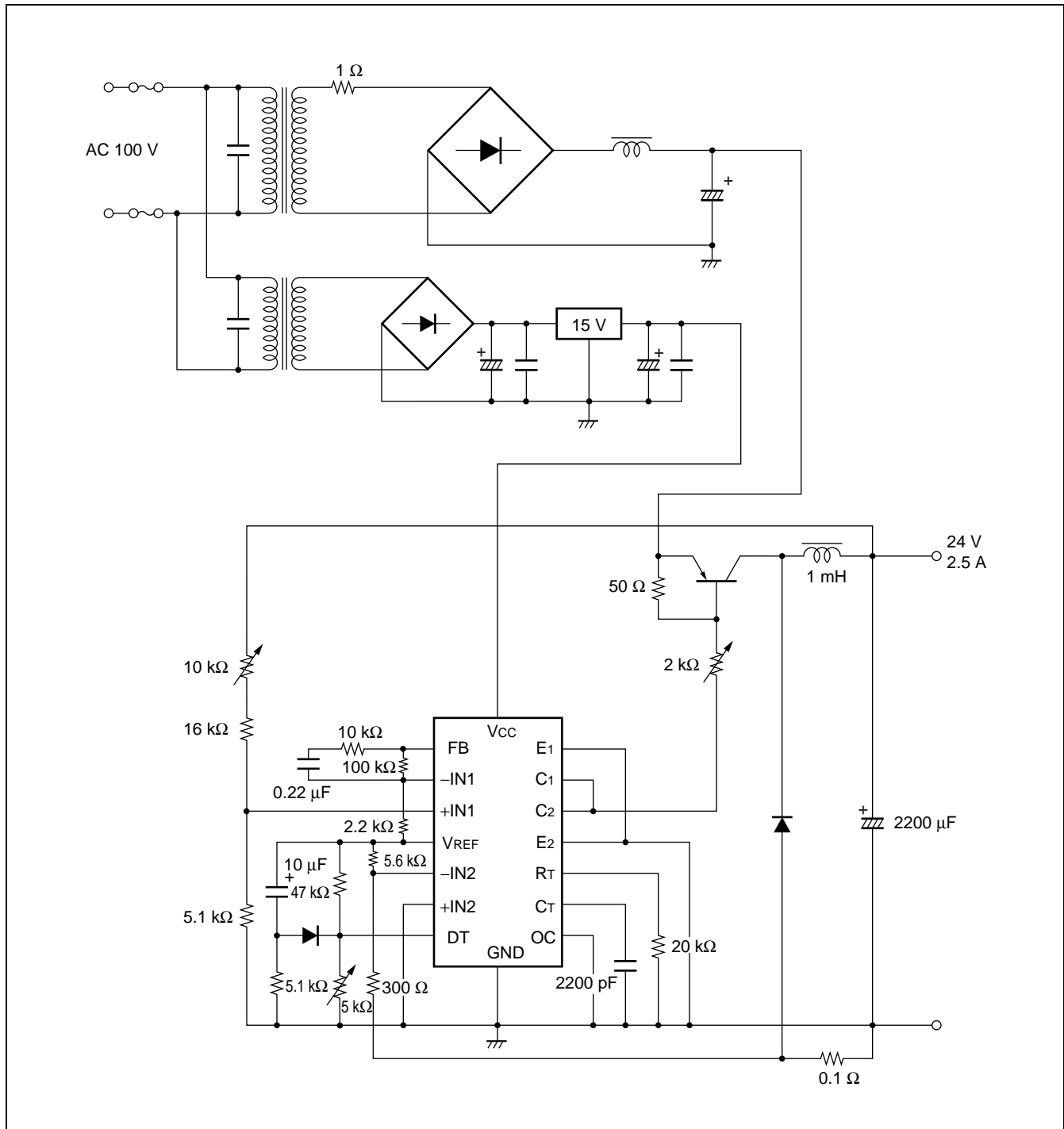

# MB3759

## (2) Inverter regulator

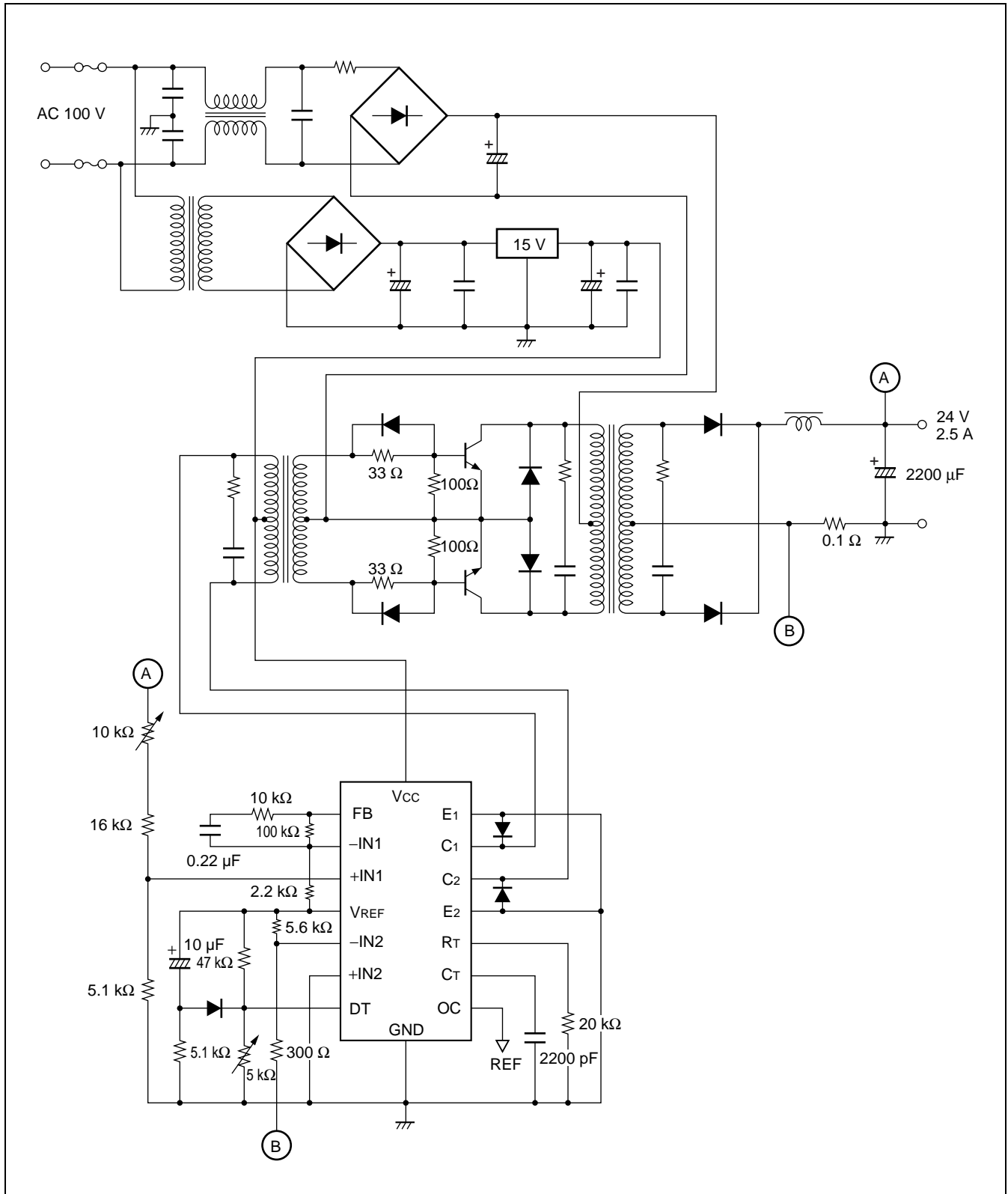

## ■ ORDERING INFORMATION

Part number	Package	Remarks
MB3759P	16-pin plastic DIP (DIP-16P-M04)	
MB3759C	16-pin ceramic DIP (DIP-16C-C01)	
MB3759PF	16-pin plastic SOP (FPT-16P-M06)	

# MB3759

## ■ PACKAGE DIMENSIONS

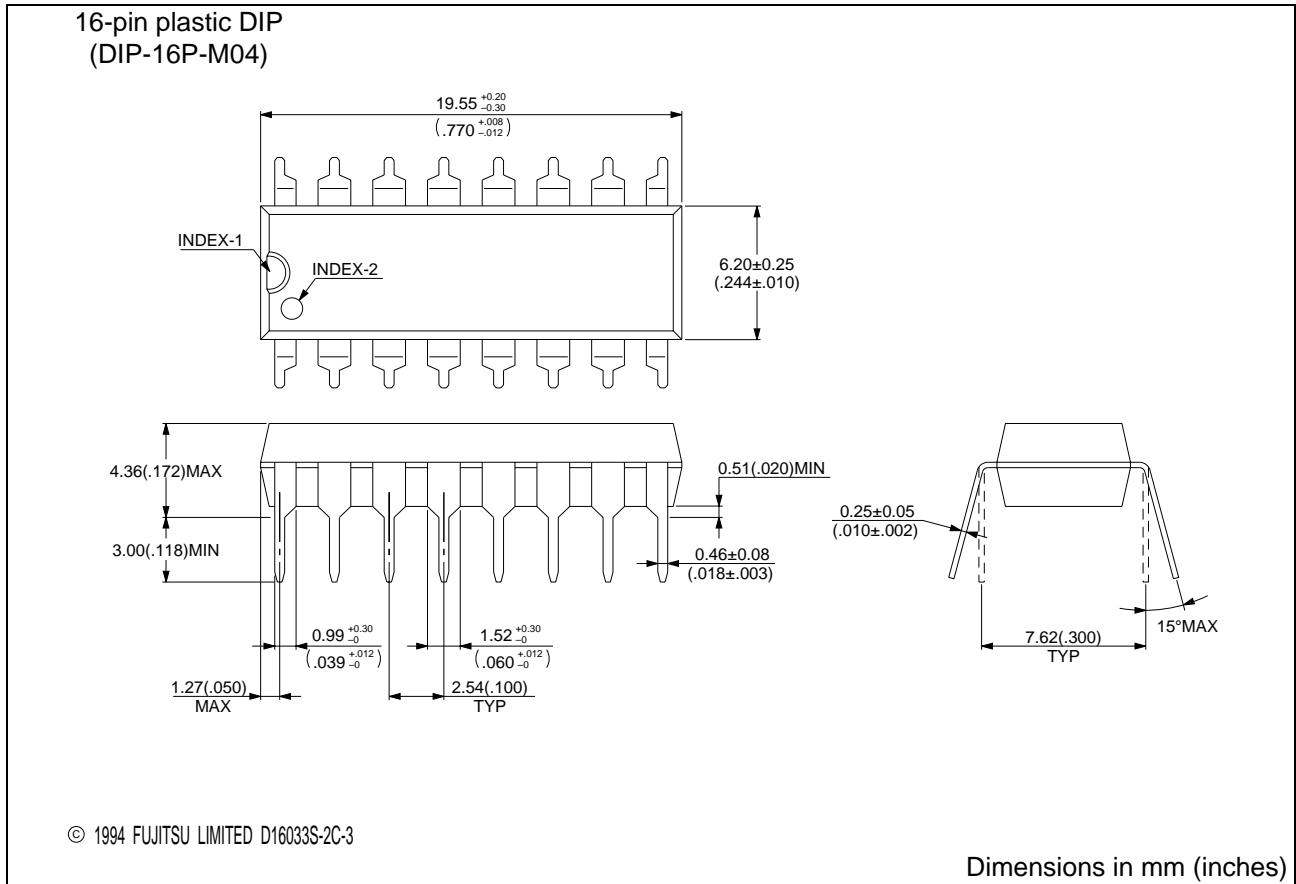

© 1994 FUJITSU LIMITED D16033S-2C-3

Dimensions in mm (inches)

(Continued)



(Continued)

16-pin ceramic DIP  
(DIP-16C-C01)

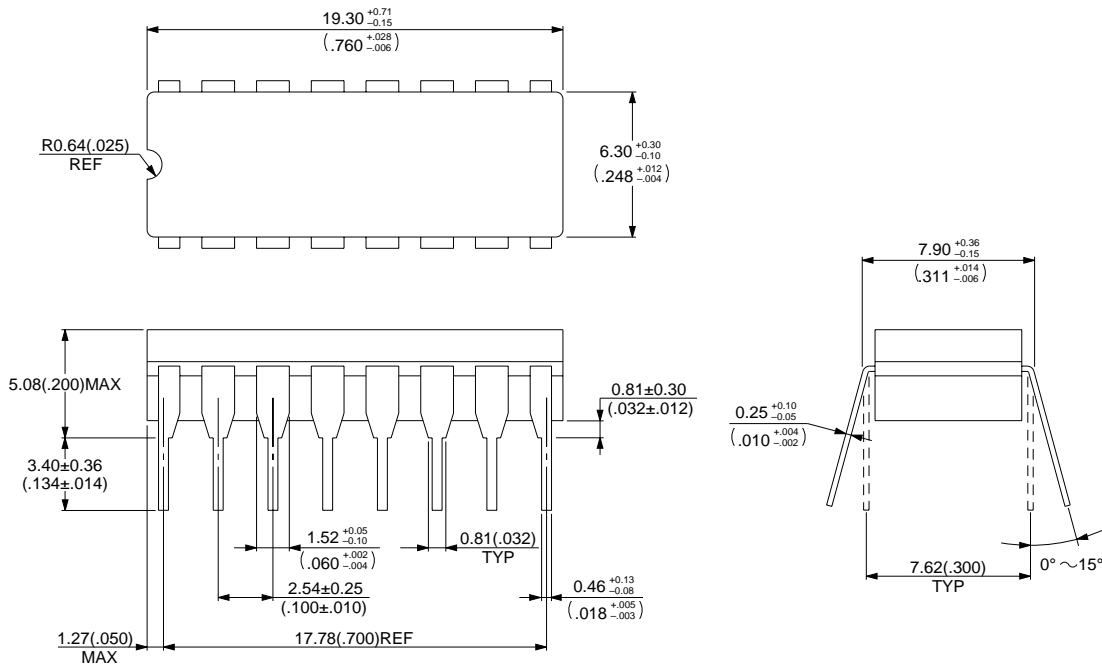

© 1994 FUJITSU LIMITED D16011SC-2-3

Dimensions in mm (inches)

(Continued)

# MB3759

(Continued)

16-pin plastic SOP  
(FPT-16P-M06)

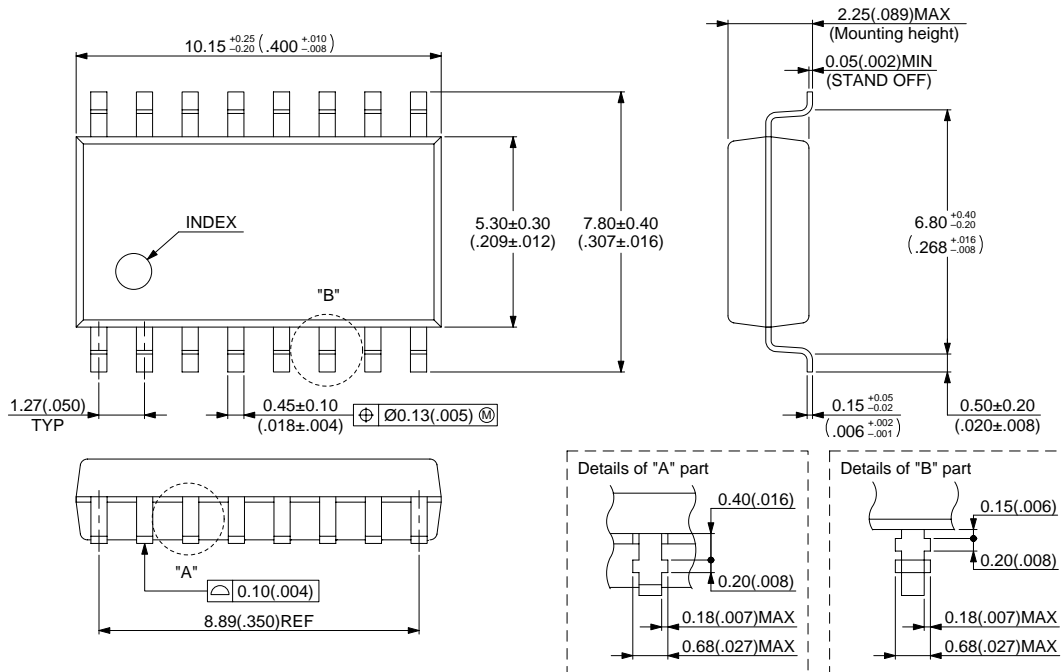

© 2000 FUJITSU LIMITED F16015S-2C-5

Dimensions in mm (inches)

## FUJITSU LIMITED

*For further information please contact:*

### **Japan**

FUJITSU LIMITED  
Corporate Global Business Support Division  
Electronic Devices  
KAWASAKI PLANT, 4-1-1, Kamikodanaka,  
Nakahara-ku, Kawasaki-shi,  
Kanagawa 211-8588, Japan  
Tel: +81-44-754-3763  
Fax: +81-44-754-3329

<http://www.fujitsu.co.jp/>

### **North and South America**

FUJITSU MICROELECTRONICS, INC.  
3545 North First Street,  
San Jose, CA 95134-1804, U.S.A.  
Tel: +1-408-922-9000  
Fax: +1-408-922-9179

Customer Response Center  
*Mon. - Fri.: 7 am - 5 pm (PST)*  
Tel: +1-800-866-8608  
Fax: +1-408-922-9179

<http://www.fujitsumicro.com/>

### **Europe**

FUJITSU MICROELECTRONICS EUROPE GmbH  
Am Siebenstein 6-10,  
D-63303 Dreieich-Buchsschlag,  
Germany  
Tel: +49-6103-690-0  
Fax: +49-6103-690-122

<http://www.fujitsu-fme.com/>

### **Asia Pacific**

FUJITSU MICROELECTRONICS ASIA PTE. LTD.  
#05-08, 151 Lorong Chuan,  
New Tech Park,  
Singapore 556741  
Tel: +65-281-0770  
Fax: +65-281-0220

<http://www.fmap.com.sg/>

### **Korea**

FUJITSU MICROELECTRONICS KOREA LTD.  
1702 KOSMO TOWER, 1002 Daechi-Dong,  
Kangnam-Gu, Seoul 135-280  
Korea  
Tel: +82-2-3484-7100  
Fax: +82-2-3484-7111

All Rights Reserved.

The contents of this document are subject to change without notice. Customers are advised to consult with FUJITSU sales representatives before ordering.

The information and circuit diagrams in this document are presented as examples of semiconductor device applications, and are not intended to be incorporated in devices for actual use. Also, FUJITSU is unable to assume responsibility for infringement of any patent rights or other rights of third parties arising from the use of this information or circuit diagrams.

The contents of this document may not be reproduced or copied without the permission of FUJITSU LIMITED.

FUJITSU semiconductor devices are intended for use in standard applications (computers, office automation and other office equipments, industrial, communications, and measurement equipments, personal or household devices, etc.).

#### **CAUTION:**

Customers considering the use of our products in special applications where failure or abnormal operation may directly affect human lives or cause physical injury or property damage, or where extremely high levels of reliability are demanded (such as aerospace systems, atomic energy controls, sea floor repeaters, vehicle operating controls, medical devices for life support, etc.) are requested to consult with FUJITSU sales representatives before such use. The company will not be responsible for damages arising from such use without prior approval.

Any semiconductor devices have inherently a certain rate of failure. You must protect against injury, damage or loss from such failures by incorporating safety design measures into your facility and equipment such as redundancy, fire protection, and prevention of over-current levels and other abnormal operating conditions.

If any products described in this document represent goods or technologies subject to certain restrictions on export under the Foreign Exchange and Foreign Trade Control Law of Japan, the prior authorization by Japanese government should be required for export of those products from Japan.