

ASSP For Power Management Applications

1-channel DC/DC Converter IC with Synchronous Rectifier

MB3885

■ DESCRIPTION

The MB3885 is a 1-channel DC/DC converter IC using pulse width modulation (PWM) and synchronous rectification, designed for down conversion applications.

This device is a power supply with high output drive capacity. Synchronous rectification also provides for high efficiency.

In addition, a 5 V regulator is built in to reduce the number of system components. The result is an ideal built-in power supply for driving products with high speed CPU's such as home TV game devices and notebook PC's.

■ FEATURES

- Synchronous rectification for high efficiency
- Supply voltage range : 5.5 V to 18 V
- Built-in high-precision reference voltage circuit : $2.5\text{ V} \pm 1\%$
- Error Amp. threshold voltage : $1.25\text{ V} \pm 1\%$ (0 °C to 85 °C)
- Oscillator frequency range : 10 kHz to 500 kHz
- Built-in soft start circuit with error Amp. input control
- Totem pole type output for N-ch MOSFET

■ PACKAGE

20-pin Plastic SSOP

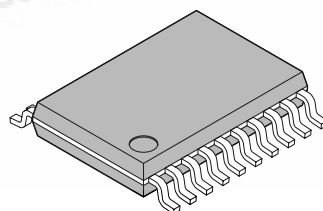

(FPT-20P-M03)

MB3885

■ PIN ASSIGNMENTS

(TOP VIEW)

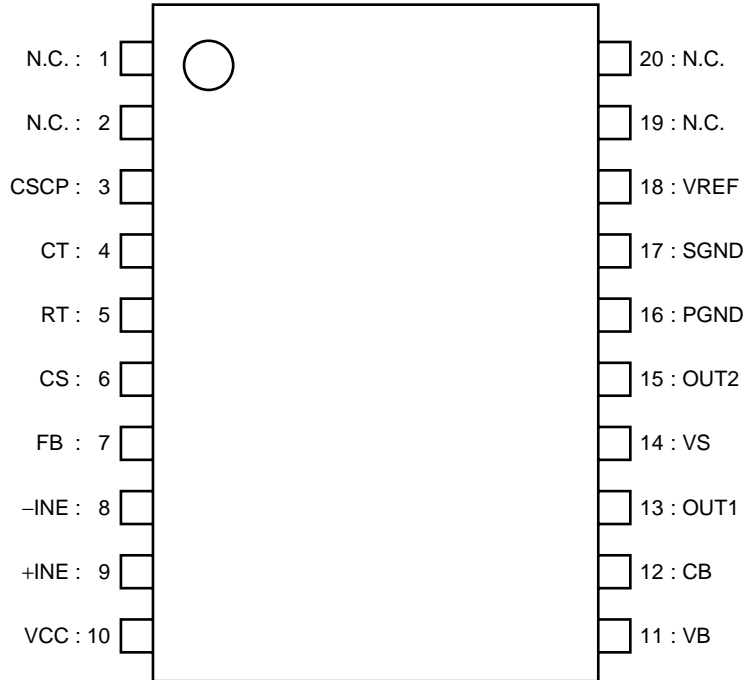

(FPT-20P-M03)

■ PIN DESCRIPTIONS

Pin No.	Symbol	I/O	Description
1	N.C.	—	No connection
2	N.C.	—	No connection
3	CSCP	—	Timer latch short protection capacitor connection terminal
4	CT	—	Triangular wave oscillator frequency setting capacitor connection terminal
5	RT	—	Triangular wave oscillator frequency setting resistor connection terminal
6	CS	—	Soft start capacitor connection terminal (Also used as output control)
7	FB	O	Error Amp. output terminal
8	-INE	I	Error Amp. inverted input terminal
9	+INC	I	Overvoltage comparator non-inverted input terminal
10	VCC	—	Reference voltage, control circuit power supply terminal
11	VB	O	Output circuit bias output terminal
12	CB	—	Output bootstrap terminal Insert a capacitor between the CB and VS terminals, to bootstrap the IC internal output transistor.
13	OUT1	O	Totem pole output terminal (External main side FET gate drive)
14	VS	—	External main side FET source connection terminal
15	OUT2	O	Totem pole output terminal. (External synchronous rectifier side FET gate drive)
16	PGND	—	Ground terminal
17	SGND	—	Ground terminal
18	VREF	O	Reference voltage output terminal
19	N.C.	—	No connection
20	N.C.	—	No connection

MB3885

■ BLOCK DIAGRAM

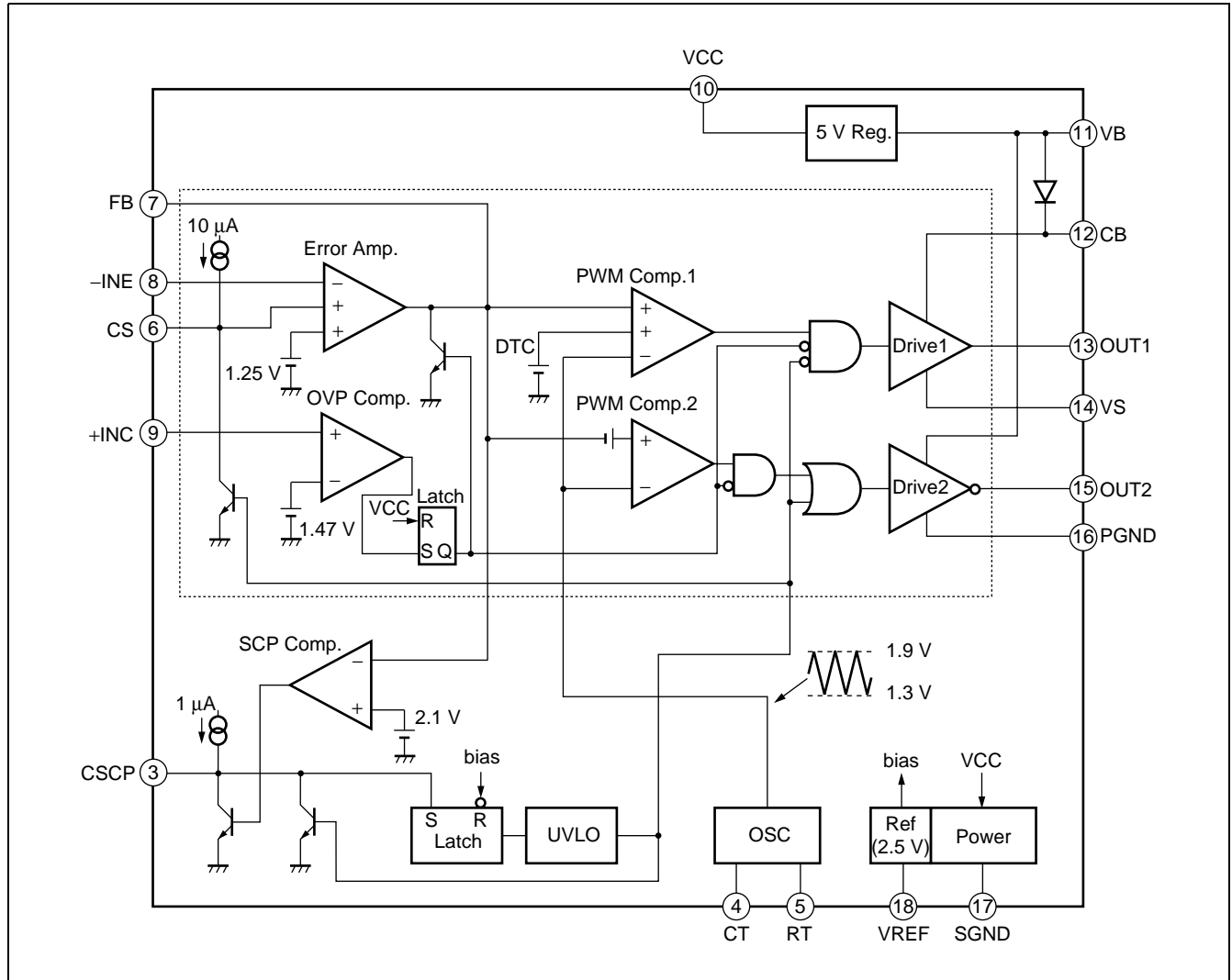

■ ABSOLUTE MAXIMUM RATINGS

Parameter	Symbol	Conditions	Rating		Unit
			Min.	Max.	
Supply voltage	V_{CC}	—	—	20	V
Boot voltage	V_{CB}	CB terminal	—	25	V
Output current	I_o	—	—	120	mA
Peak output current	I_{OP}	Duty $\leq 5\%$ ($t = 1 / f_{osc} \times \text{Duty}$)	—	800	mA
Power dissipation	P_D	$T_a \leq +25\text{ }^\circ\text{C}$	—	555*	mW
Storage temperature	T_{stg}	—	-55	+125	$^\circ\text{C}$

* : The package is mounted on the dual-sided epoxy board (10cm × 10cm).

WARNING: Semiconductor devices can be permanently damaged by application of stress (voltage, current, temperature, etc.) in excess of absolute maximum ratings. Do not exceed these ratings.

MB3885

■ RECOMMENDED OPERATING CONDITIONS

Parameter	Symbol	Conditions	Value			Unit
			Min.	Typ.	Max.	
Supply voltage	V _{CC}	—	5.5	12	18	V
Boot voltage	V _{CB}	CB terminal	—	—	23	V
Reference voltage output current	I _{OR}	VREF terminal	-1	—	0	mA
Bias output current	I _{OB}	VB terminal	-1	—	0	mA
Input voltage	V _{IN}	-INE terminal	0	—	V _{CC} - 1.8	V
	V _{INC}	+INC terminal	0	—	V _{CC}	V
Output current	I _O	—	-100	—	100	mA
Peak output current	I _{OP}	Duty ≤ 5% (t = 1 / f _{osc} × Duty)	-700	—	700	mA
Oscillator frequency	f _{OSC}	—	10	200	500	kHz
Timing resistor	R _T	—	6.8	10	12	kΩ
Timing capacitor	C _T	—	150	470	15000	pF
Boot capacitor	C _B	—	—	0.1	1.0	μF
Reference voltage output capacitor	C _{REF}	VREF terminal	—	0.1	1.0	μF
Bias output capacitor	C _{VB}	VB terminal	1.0	4.7	10	μF
Soft start capacitor	C _S	—	—	0.1	1	μF
Short detection capacitor	C _{SCP}	—	—	0.01	0.1	μF
Operating ambient temperature	T _a	—	-30	+25	+85	°C

WARNING: The recommended operating conditions are required in order to ensure the normal operation of the semiconductor device. All of the device's electrical characteristics are warranted when the device is operated within these ranges.

Always use semiconductor devices within their recommended operating condition ranges. Operation outside these ranges may adversely affect reliability and could result in device failure.

No warranty is made with respect to uses, operating conditions, or combinations not represented on the data sheet. Users considering application outside the listed conditions are advised to contact their FUJITSU representatives beforehand.

■ ELECTRICAL CHARACTERISTICS

(VCC = 12 V, VB = 0 mA, VREF = 0 mA, Ta = +25 °C)

Parameter	Symbol	Pin No.	Conditions	Value			Unit	
				Min.	Typ.	Max.		
1. Reference Voltage Block [Ref]	Output voltage	V _{REF}	18	Ta = +25 °C	2.475	2.500	2.525	V
		$\frac{\Delta V_{REF}}{V_{REF}}$	18	Ta = 0 °C to +85 °C	—	0.5*	—	%
	Input stability	Line	18	VCC = 5.5 V to 18 V	—	1	10	mV
	Load stability	Load	18	VREF = 0 mA to -1 mA	—	3	10	mV
	Short output current	I _{OS}	18	VREF = 2 V	-28	-14	-7	mA
2. Bias Voltage Block [VB]	Output voltage	VB	11	—	4.95	5.05	5.15	V
3. Undervoltage Lockout Circuit Block [UVLO]	Threshold voltage	V _{TH}	10	VCC = $\sqrt{\quad}$	2.6	2.9	3.2	V
	Hysteresis width	V _H	10	—	—	0.2*	—	V
	Reset voltage	V _{RST}	10	—	1.7	2.1	2.5	V
4. Soft Start Block [CS]	Charge current	I _{CS}	6	—	-14	-10	-6	μA
5. Short Detection Comparator Block [SCP]	Threshold voltage	V _{TH}	3	—	0.63	0.68	0.73	V
	Input source current	I _{CSCP}	3	—	-1.4	-1.0	-0.6	μA
	Short detection time	t _{SCP}	3	CSCP = 0.01 μF	4.5	6.8	12.2	ms
6. Triangular Wave Oscillator Block [OSC]	Oscillator frequency	f _{OSC}	4	RT = 10 kΩ, CT = 470 pF	170	190	210	kHz
	Frequency temperature variation rate	$\frac{\Delta f_{OSC}}{f_{OSC}}$	4	Ta = 0 °C to +85 °C	—	1*	—	%
7. Error Amp Block [Error Amp.]	Threshold voltage	V _{TH1}	8	FB = 1.6 V, Ta = +25 °C	1.241	1.2500	1.259	V
		V _{TH2}	8	FB = 1.6 V, Ta = 0 °C to +85 °C	1.2375	1.2500	1.2625	V
	Input bias current	I _B	8	-INE = 0 V	-200	-20	—	nA
	Voltage gain	A _V	7	DC	60	100	—	dB

* : Standard design value

(Continued)

MB3885

(VCC = 12 V, VB = 0 mA, VREF = 0 mA, Ta = +25 °C)





Parameter	Symbol	Pin No.	Conditions	Value			Unit	
				Min.	Typ.	Max.		
7. Error Amp Block [Error Amp.]	Frequency band width	BW	7	AV = 0 dB	—	800*	—	kHz
	Output voltage	V _{FBH}	7	—	2.2	2.5	—	V
		V _{FBL}	7	—	—	0.8	1.0	V
	Output source current	I _{SOURCE}	7	FB = 1.6 V	—	-100	-45	μA
Output sink current	I _{SINK}	7	FB = 1.6 V	1.5	9.0	—	mA	
8. PWM Comparator Block [PWM Comp.1, PWM Comp.2]	Threshold voltage	V _{TL}	7	Duty cycle = 0%	1.2	1.3	—	V
		V _{TH}	7	Duty cycle = Dtr	—	1.81	2.0	V
9. Dead time Adjustment Block [DTC]	Maximum duty cycle	Dtr	13	RT = 10 kΩ, CT = 470 pF	85	90	95	%
10. Output Block [Drive]	Output current (main side)	I _{SOURCE1}	13	Duty ≤ 5% (t = 1 / fosc × Duty)	—	-700*	—	mA
		I _{SINK1}	13	Duty ≤ 5% (t = 1 / fosc × Duty)	—	900*	—	mA
	Output voltage (main side)	V _{OH1}	13	OUT1 = -100 mA, CB = 17 V, VS = 12 V	CB - 2.5	CB - 0.9	—	V
		V _{OL1}	13	OUT1 = 100 mA, CB = 17 V, VS = 12 V	—	VS + 0.9	VS + 1.4	V
	Output current (synchronous rectifier side)	I _{SOURCE2}	15	Duty ≤ 5% (t = 1 / fosc × Duty)	—	-750*	—	mA
		I _{SINK2}	15	Duty ≤ 5% (t = 1 / fosc × Duty)	—	900*	—	mA
	Output voltage (synchronous rectifier side)	V _{OH2}	15	OUT2 = -100 mA	2.5	4.1	—	V
		V _{OL2}	15	OUT2 = 100 mA	—	1.0	1.4	V
Diode voltage	V _D	12	VB = 10 mA	—	0.9	1.1	V	

* : Standard design value

(Continued)

(Continued)

(VCC = 12 V, VB = 0 mA, VREF = 0 mA, Ta = +25 °C)

Parameter		Symbol	Pin No.	Conditions	Value			Unit
					Min.	Typ.	Max.	
10. Output Block [Drive]	Dead time	t _{D1}	13, 15	RT = 10 kΩ, CT = 470 pF OUT1 = OUT2 = OPEN, VS = 0 V OUT2 :  - OUT1 : 	100	200	—	ns
		t _{D2}		RT = 10 kΩ, CT = 470 pF OUT1 = OUT2 = OPEN, VS = 0 V OUT1 :  - OUT2 : 	100	250	—	ns
11. Overvoltage Detection Comparator Block [OVP]	Threshold voltage	V _{TH}	9	+INC = 	1.44	1.47	1.50	V
	Input bias current	I _B	9	+INC = 0 V	-200	-30	—	nA
12. General	Power supply current	I _{CC}	10	—	—	6.5	9.8	mA

MB3885

■ TYPICAL CHARACTERISTICS

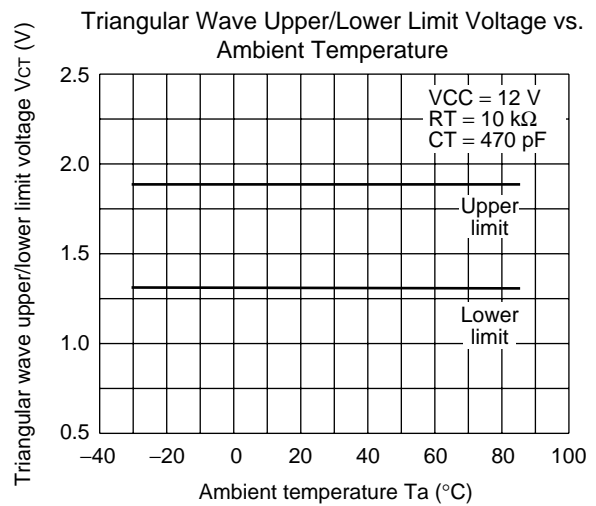
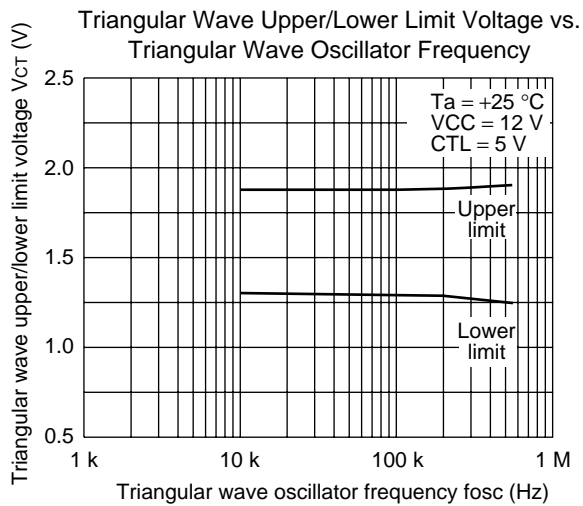
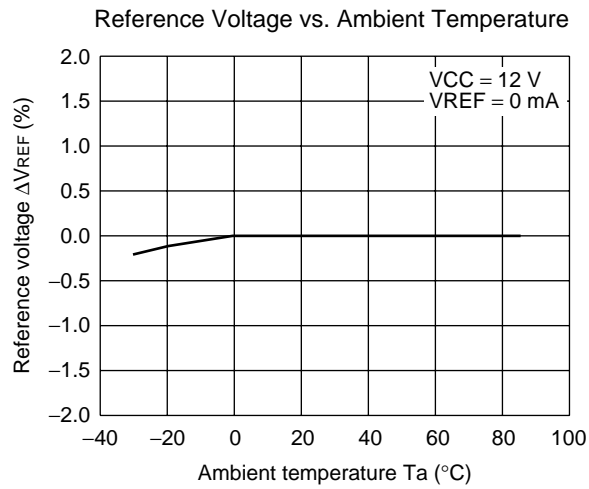
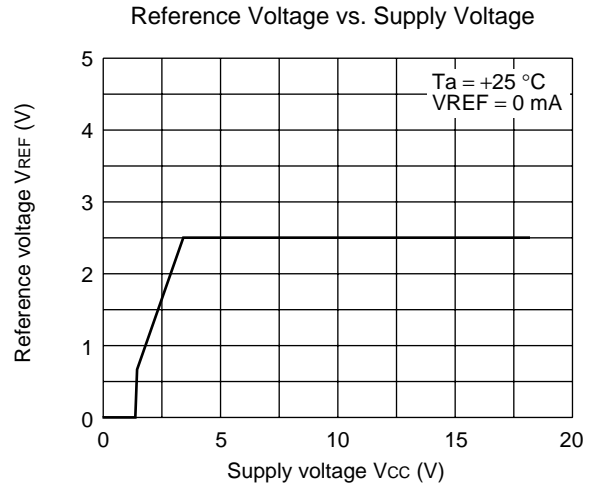
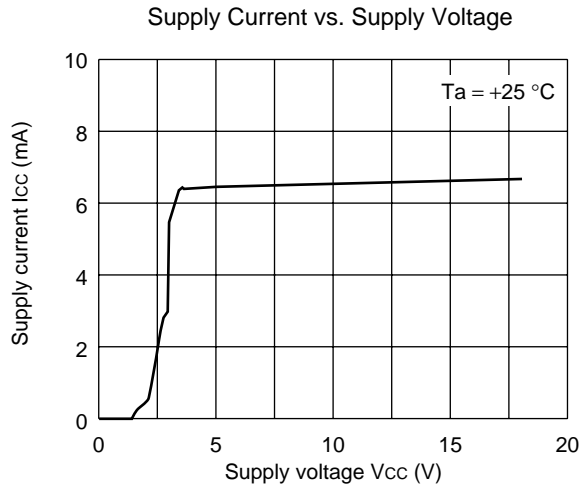

(Continued)

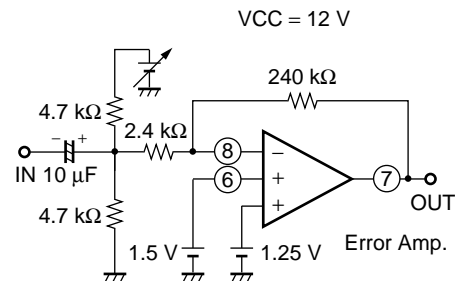
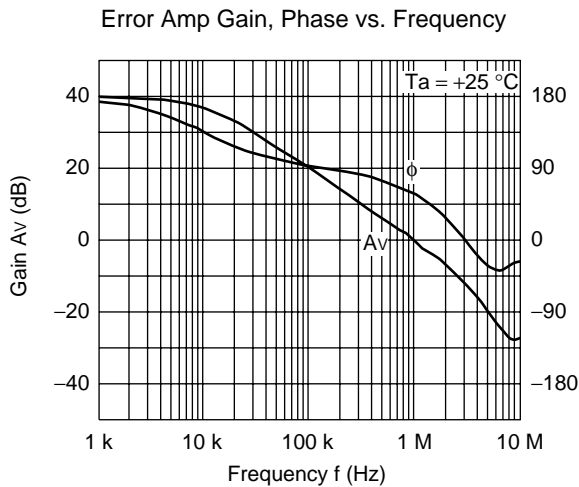
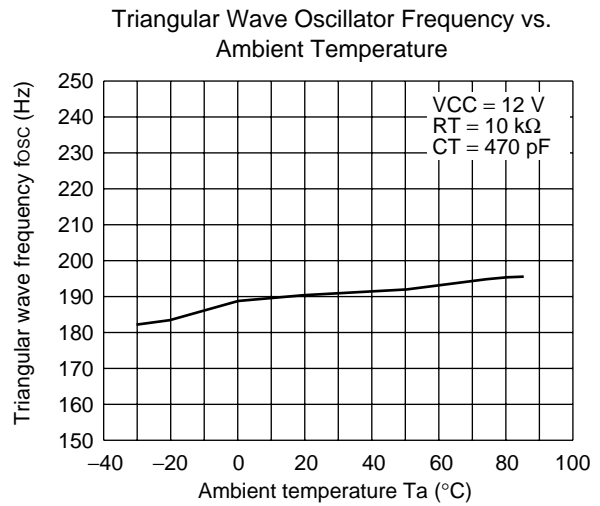
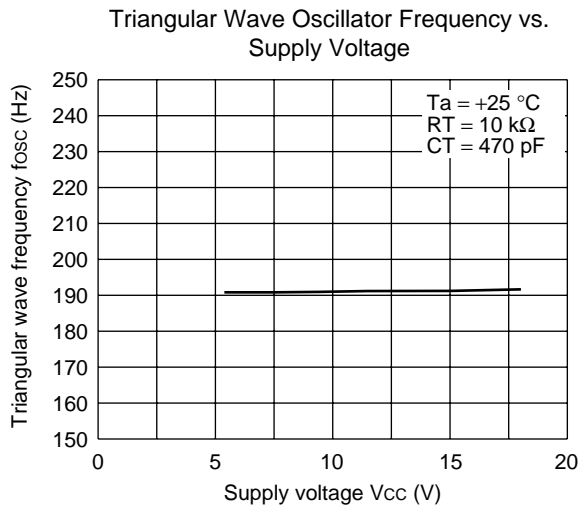
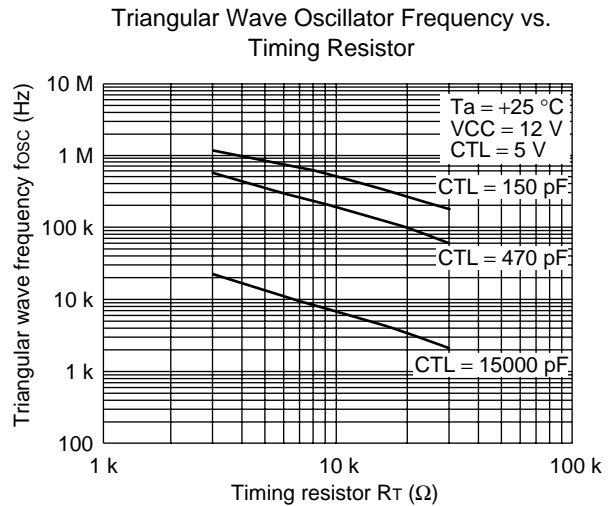
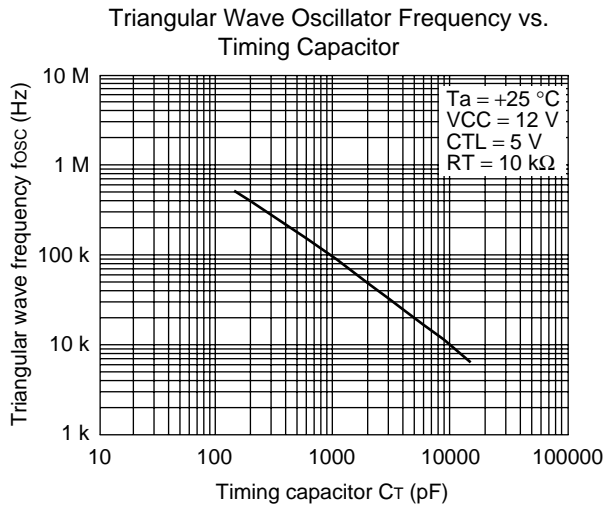

MB3885

(Continued)

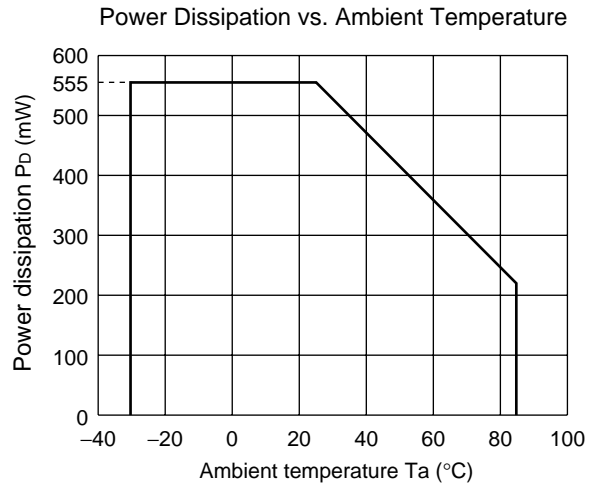

■ FUNCTION DESCRIPTION

1. DC/DC Converter Function

(1) Reference Voltage Block

The reference voltage circuit takes the voltage feed from the power supply terminal (pin 10) and generates a temperature compensated reference voltage (2.5 V typ.) , for use as the reference voltage for the power supply control unit.

Also, an external load current can be obtained from the power supply at the VREF terminal (pin 18) , up to a maximum of 1 mA.

(2) Triangular Wave Oscillator Block

A triangular waveform with amplitude 1.3 V to 1.9 V can be generated by connecting a timing capacitor and resistor to the CT terminal (pin 4) and RT terminal (pin 5) , respectively.

The triangular oscillator waveform can be input to the IC's internal PWM comparator, as well as supplied externally from the CT terminal.

(3) Error Amp Block (Error Amp.)

The error Amp. is an amplifier that detects the output voltage from the DC/DC converter and outputs a PWM control signal. The error Amp. has a broad in-phase input voltage range of 0 to $V_{CC}-1.8$ V that can be easily set by the external power supply.

In addition, an arbitrary loop gain can be set up by connecting a feedback resistor and capacitor between the error Amp. output pin and inverter input pin, providing stable phase compensation to the system.

Also, power-on rush current can be prevented by connecting a soft start capacitor between the error Amp. non-inverted input pins CS terminal (pin 6) . The soft start function operates with a stable soft start time that is not dependent on the output load of the DC/DC converter.

(4) PWM Comparator Block (PWM Comp.)

This is a voltage - pulse width modulator that controls the output duty according to the input voltage.

Main side : Turns the output FET on in the intervals in which the error Amp. output voltage is higher than the triangular wave voltage.

Synchronous rectifier side : Turns the output FET on in the intervals in which the triangular wave voltage the is lower than error Amp. voltage.

(5) Output Block

The output block has totem pole configuration on both the main side and synchronous rectifier side, and can drive an external N-ch MOSFET.

Also, the high output drive capability (700 mA Max. : duty \leq 5%) provides high gate-source capacitor, enabling the use of low on-resistor FET devices.

MB3885

2. Control Functions

Output ON/OFF control is provided by using the CS terminal (pin 6) setting functions.

Output On/Off Setting Functions

CS terminal voltage level	Output state
GND	OFF
Hi-Z	ON

3. Protective Functions

(1) Timer Latch Short Circuit Protection (SCP)

The short circuit protection comparators read the output voltage levels. If the output voltage falls below the short detection voltage, the timer circuit is activated to start charging the external capacitor Cscp connected to the CSCP terminal (pin 3) .

When capacitor voltage reaches approximately 0.68 V the output FET turns off, setting the idle interval to 100%. Once the protection circuit is activated, it can be reset by turning the power supply off and on again. (See “Setting the Timer Latch Short Circuit Protector Time Constant.”)

(2) Undervoltage Lockout Circuit Block (UVLO)

Transient status during normal power-on or momentary drops in supply voltage can cause abnormal operation in an control IC, leading to damage or degradation of system components. The undervoltage lockout circuit prevents such abnormal operations by reading the internal reference voltage level and switching the output FET off, setting the idle interval to 100% and holding the CSCP terminal (pin 3) to “L” level.

System operation is restored when the supply voltage rises back about the undervoltage lockout circuit threshold voltage.

(3) Overvoltage Protection Block (OVP)

The overvoltage protection circuit uses an overvoltage comparator (OVP Comp.) to read the output voltage levels from the DC/DC converter. If the output voltage exceeds the threshold voltage a latch is set, turning off the main side FET.

Once the protector circuit is activated, it can be reset by switching the power supply off and on again.

■ SETTING THE TIMER LATCH SHORT CIRCUIT PROTECTOR TIME CONSTANT

The error Amp. output level constantly compares operation with the short circuit protection comparator as the reference voltage.

When the DC/DC comparator load conditions are stable, the short circuit protection comparator output is at "H" level, transistor Q1 is on, and the CSCP terminal (pin 3) is held at input standby voltage

($V_{STB} = 50 \text{ mV}$).

If load conditions change rapidly, such as during a load short, causing output voltage to drop, the short circuit protection comparator output goes to "L" level. This causes the transistor Q1 to shut off, charging the short circuit protection capacitor C_{scp} (connected to the CSCP terminal) at $1 \mu\text{A}$.

Short detection time

$$t_{scp} \text{ (s)} \approx 0.68 \times C_{scp} \text{ (}\mu\text{F)}$$

When the capacitor C_{scp} is charged to the threshold voltage ($V_{TH} = 0.68 \text{ V}$) a latch is set, turning the external FET off (setting the idle interval to 100%). At this time the latch input is closed and the CSCP terminal is held at the input latch voltage ($V_l = 50 \text{ mV}$).

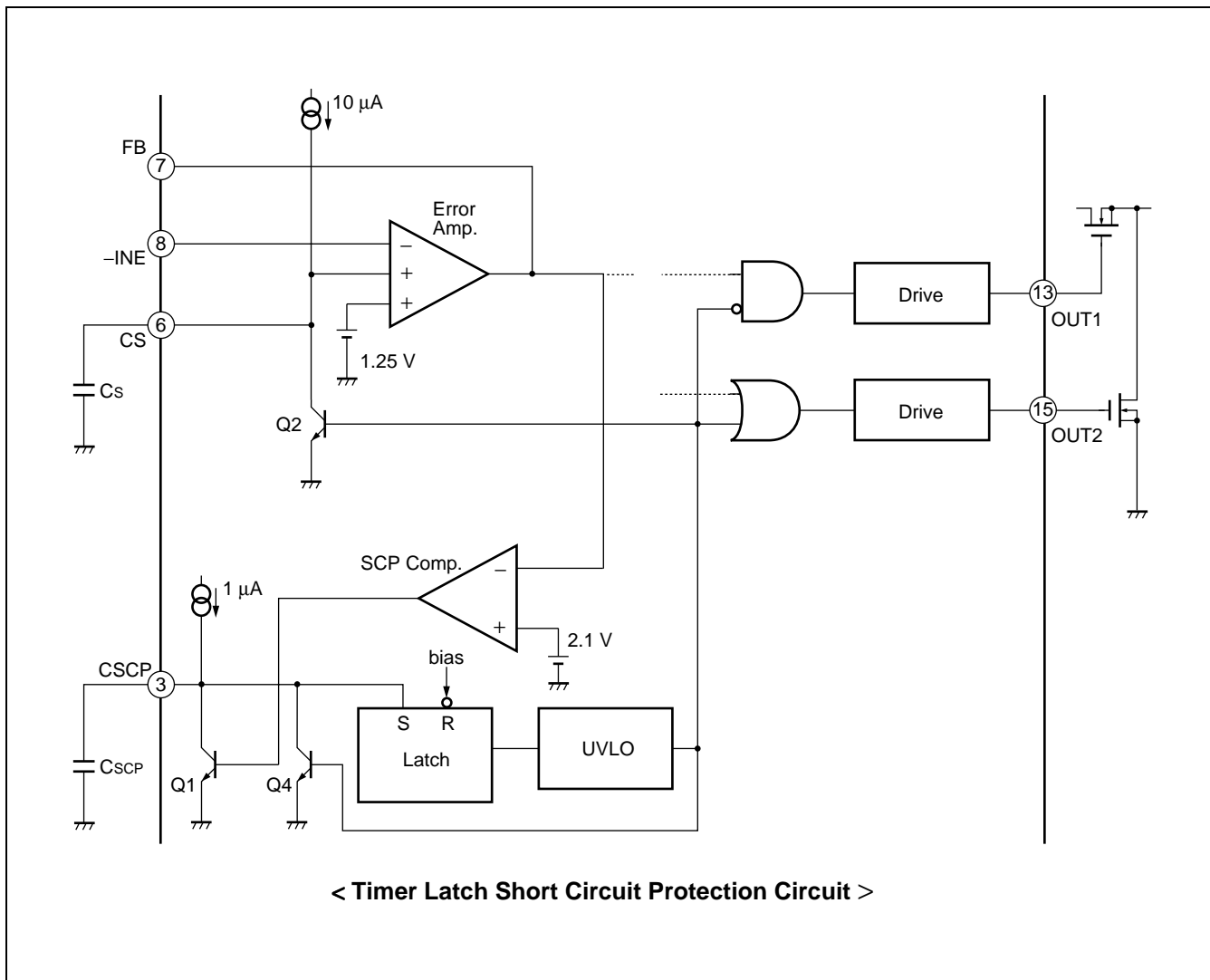

MB3885

■ PROCESSING WITHOUT USING THE CSCP TERMINAL

When the timer latch short circuit protection circuit is not used, the CSCP terminal (pin 3) should be shorted to SGND using the shortest possible connection.

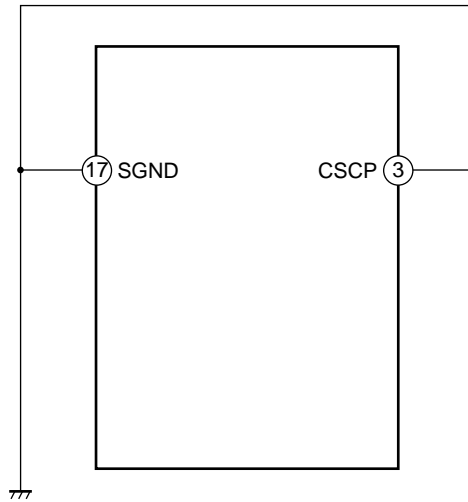

< Operation Without Using the CSCP Terminal >

■ SOFT START TIME SETTING

The soft start function prevents rush current events when the IC power is turned on, by connecting soft start capacitors (Cs) to the CS terminal (pin 6) .

When the IC is activated ($V_{CC} \geq UVLO$ threshold voltage) , Q2 is off and the CS terminals begin charging the externally connected soft start capacitors (Cs) at $10 \mu A$.

Because the error Amp. output (FB) is determined by the ratio of the lower of the two non-inverted input terminals (1.25 V, CS terminal voltage) to the inverted input terminal voltage ($-INE$) , the soft start interval (when CS terminal voltage $< 1.25 V$) FB is determined by the ratio of the $-INE$ terminal voltage and CS terminal voltage. Thus the DC/DC converter output voltage is in proportion to the rise in the CS terminal voltage as the soft start capacitor connected to the CS terminal charges. The soft start time is determined by the following formula.

Soft start time (time to output 100%)

$$t_s (s) \approx 0.125 \times C_s (\mu F)$$

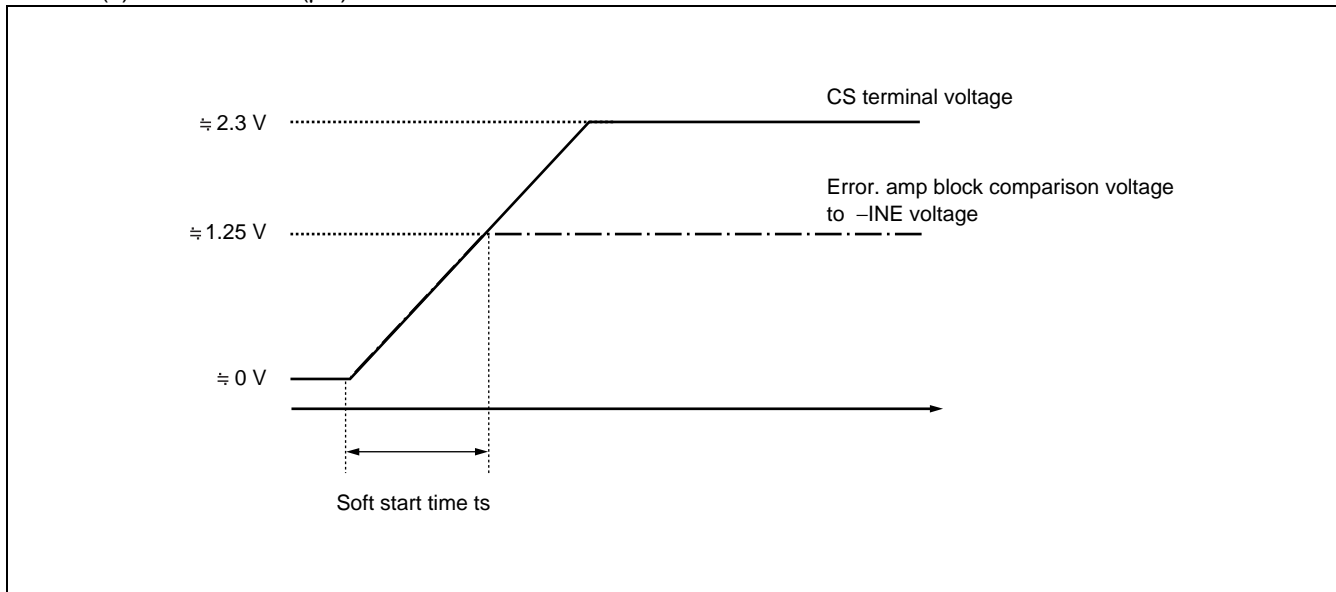

MB3885

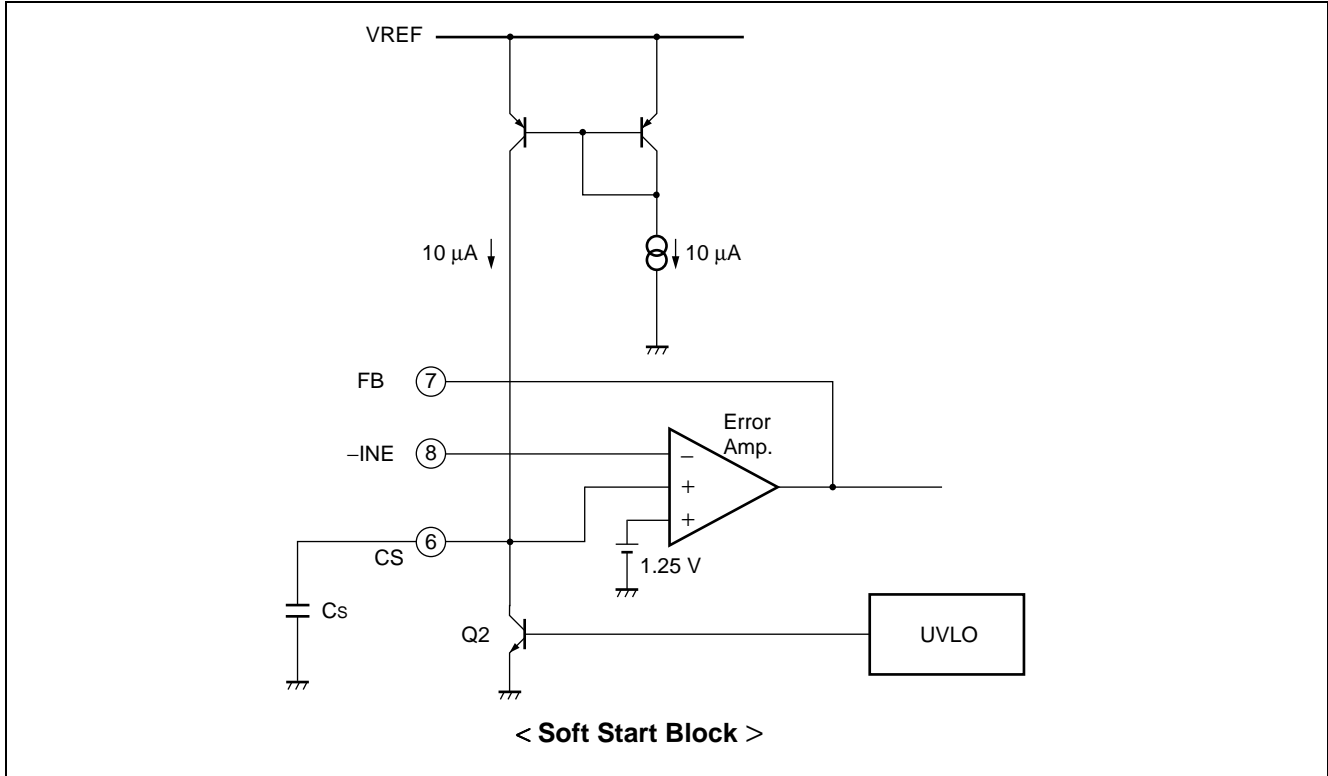

■ PROCESSING WITHOUT USING THE CS TERMINALS

When the soft start function is not used, the CS terminal (pin 6) should be left open.

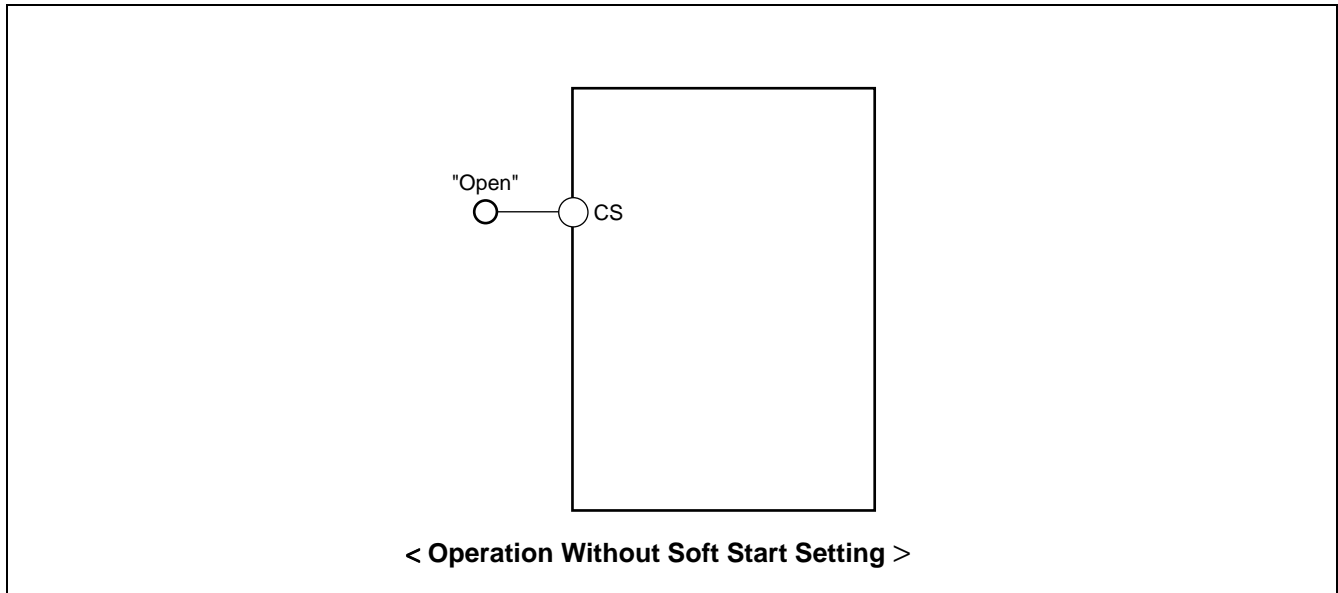

■ OSCILLATOR FREQUENCY SETTING

The oscillator frequency can be set by connecting a timing capacitor (C_T) to the CT terminal (pin 4) and a timing resistor (R_T) to the RT terminal (pin 5).

Oscillator frequency

$$f_{osc} \text{ (kHz)} \approx \frac{893000}{C_T \text{ (pF)} \cdot R_T \text{ (k}\Omega\text{)}}$$

■ OUTPUT VOLTAGE SETTING

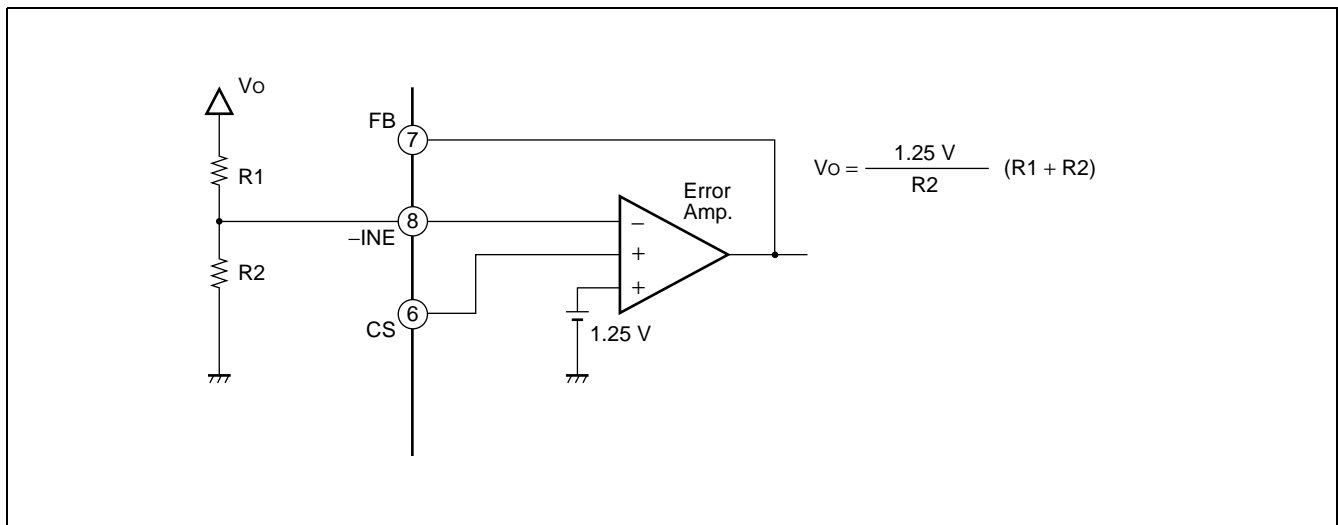

MB3885

OVERVOLTAGE PROTECTION CIRCUIT VOTAGE SETTING

Overvoltage conditions in the DC/DC converter output voltage can be detected by connecting external resistance from the DC/DC converter output voltage to the +INC terminal (pin 9) on the respective overvoltage protection comparator circuits (OVP comp.) .

When the output voltage of the DC/DC converter rises above the detection voltage, the overvoltage protection comparator (OVP Comp.) output goes to "H" level, setting a latch and shutting off.

Detection voltage

$$V_{OVP} (V) \cong 1.47 \times (R3 + R4) / R4$$

Once the protection circuit has been activated, it can be reset by lowering the VCC voltage below the reset voltage (1.7 V Min.) .

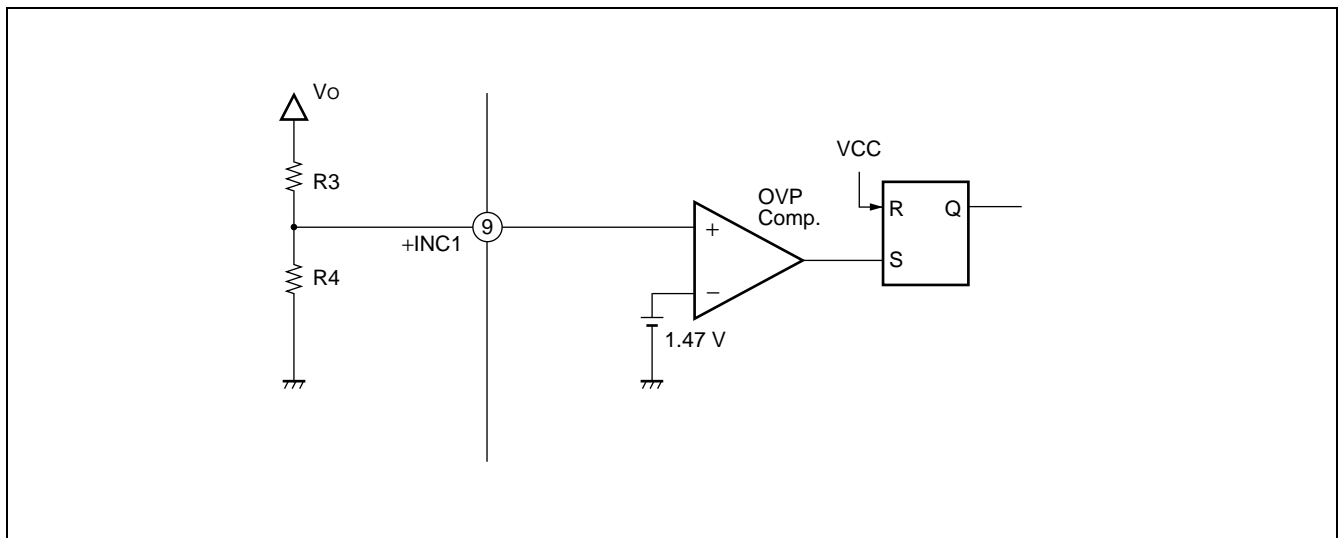

■ PRECAUTIONS RELATED TO SUPPLY VOLTAGE RANGE

Although the supply voltage range listed under recommended operating requirements is 5.5V-18V, generation of heat limits the maximum operating supply voltage since the IC's internal loss varies with the frequency of oscillation and FET's total gate charge. When using the MB 3885 in an application, caution must be taken in relation to supply voltage range.

As shown below, I_B (average current) can be determined from the total gate charge Q_{g1} , Q_{g2} , charged from the gate capacitance (C_{iss1} , C_{iss2} , C_{rss1} , C_{rss2}) of the external FET Q1, Q2, by the following formula.

$$I_B (A) = I_1 + I_2$$
$$= I_{bias1} \times \frac{T1}{T} + \frac{Q_{g1}}{T} + I_{bias2} \times \frac{T2}{T} + \frac{Q_{g2}}{T} \quad (I_{bias1} = I_{bias2} \approx 2 \text{ mA})$$

Because IC current consumption other than I_B is 6.5 mA, power consumption can be determined from the following formula.

Power consumption : P_c

$$P_c (W) \approx 0.0065 \times V_{CC} + V_{CC} \times I_B - 1 / 2 \times V_B \times I_B$$

MB3885

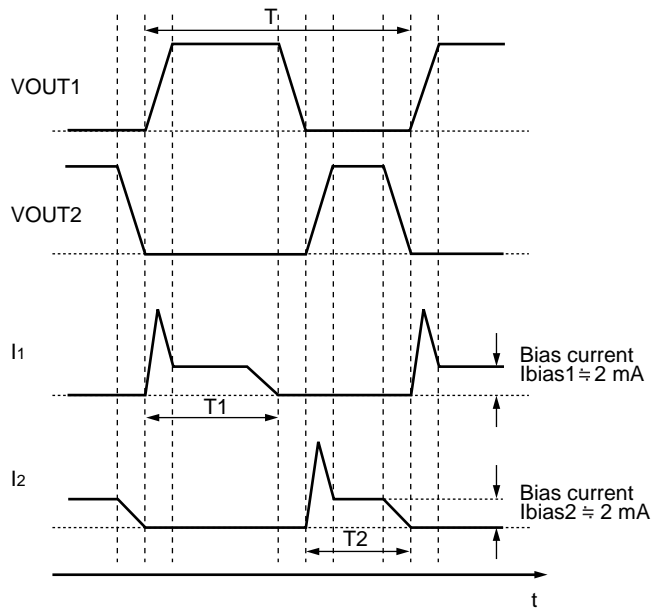
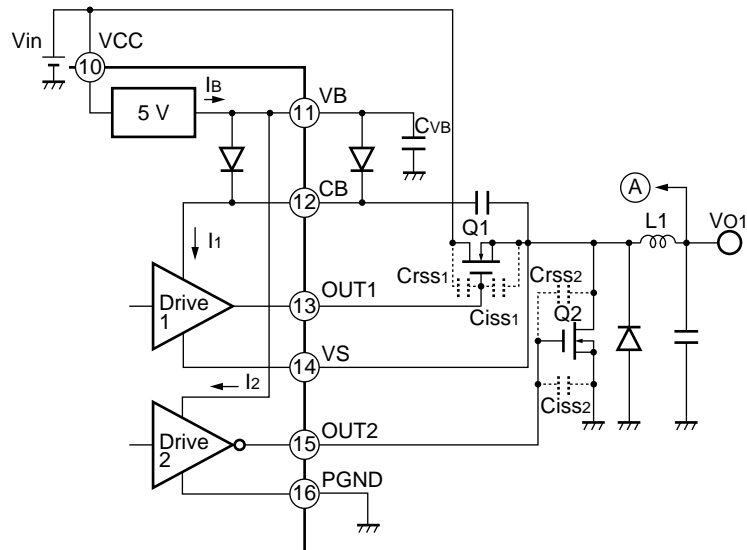

Using the above formulas to determine power consumption, settings should be made with reference to the “Power Consumption vs. Input Voltage” on the following page, as well as the “Power dissipation vs. Ambient Temperature.”

Power Consumption vs. Input Voltage (Qg Parameters)

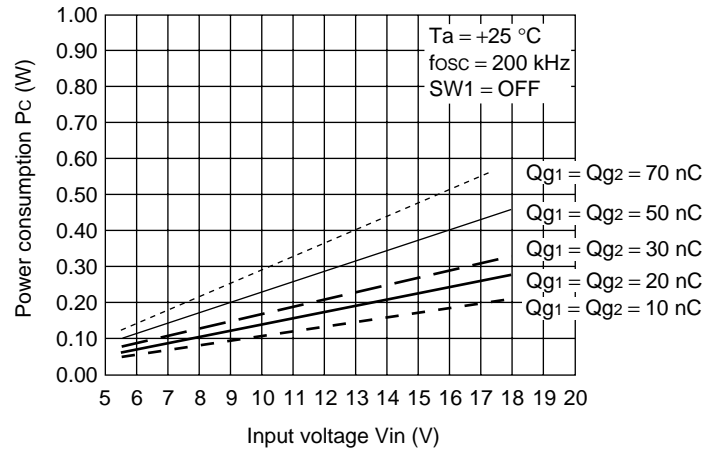

Power Consumption vs. Input Voltage (fosc Parameters)

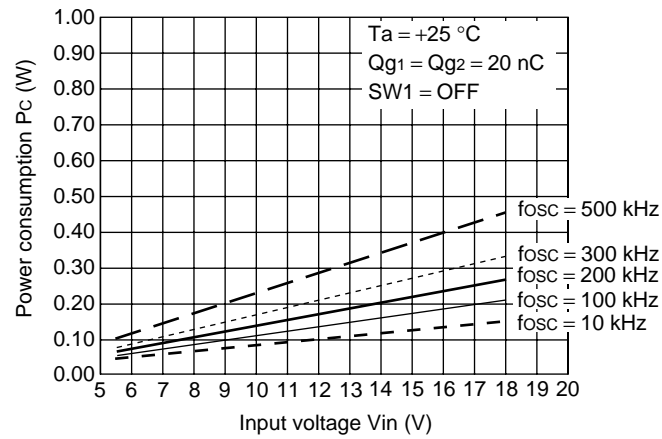

MB3885

APPLICATION CIRCUIT

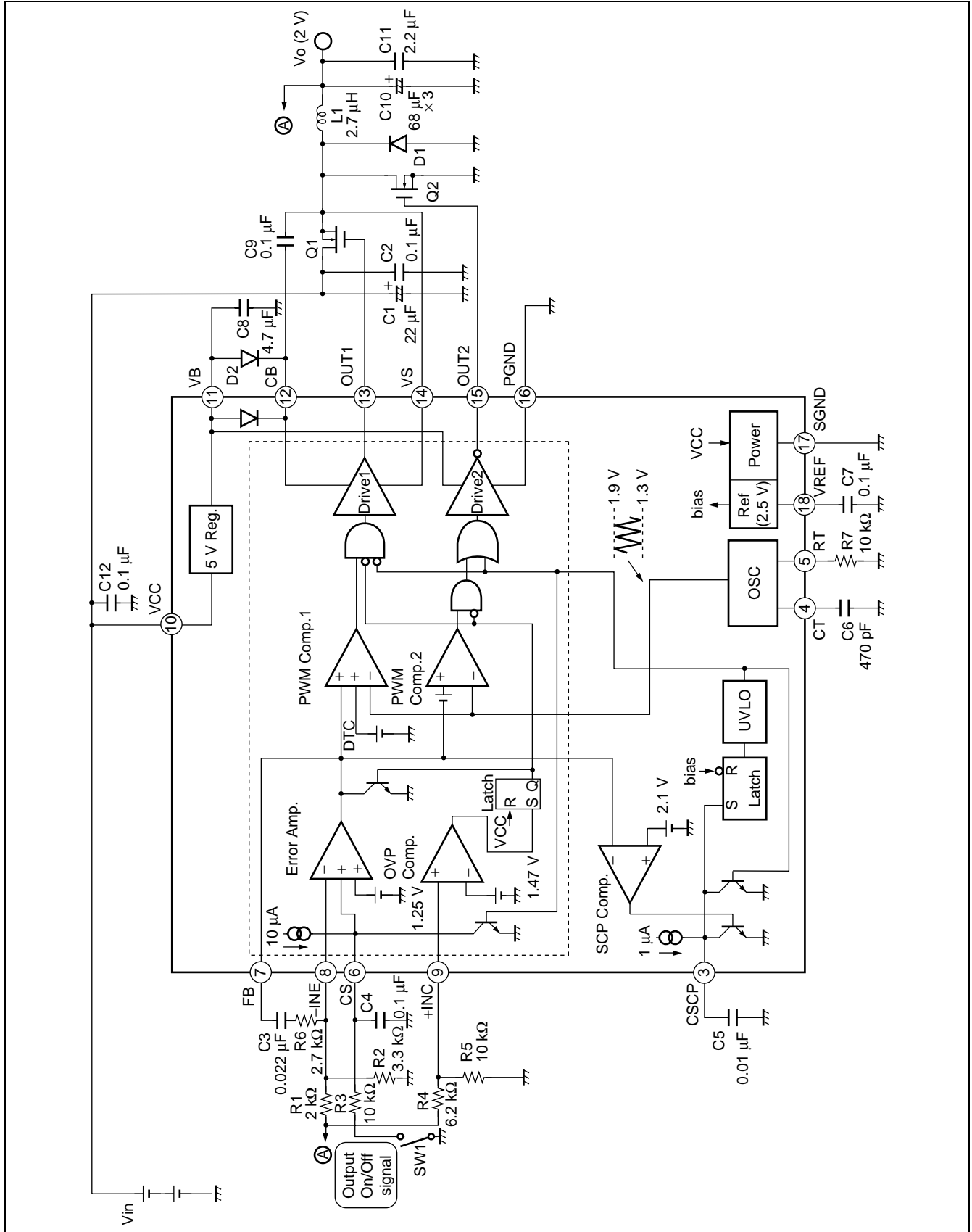

■ COMPONENT LIST

COMPONENT	ITEM	SPECIFICATION		VENDOR	PARTS No.
Q1, Q2	FET	VDS = 30 V, Qg = 23 nC (Max.)		IR	IRF7811
D1	Diode	VF = 0.35 V (Max.) , at IF = 1 A		ROHM	RB051L-40
D2	Diode	VF = 0.3 V (Max.) , at IF = 10 mA		ROHM	RB495D
L1	Coil	2.7 μ H	12 A, 4.5 m Ω	TDK	RLF12545T -2R7N8R7
C1	OS Condenser	22 μ F	25 V	—	—
C2	Ceramics Condenser	0.1 μ F	25 V		
C3	Ceramics Condenser	0.022 μ F	25 V		
C4	Ceramics Condenser	0.1 μ F	25 V		
C5	Ceramics Condenser	0.01 μ F	10 V		
C6	Ceramics Condenser	470 pF	50 V		
C7	Ceramics Condenser	0.1 μ F	25 V		
C8	Ceramics Condenser	4.7 μ F	10 V		
C9	Ceramics Condenser	0.1 μ F	25 V		
C10	Electrolytic Condenser	68 μ F	6.3 V		
C11	Ceramics Condenser	2.2 μ F	6.3 V		
C12	Ceramics Condenser	0.1 μ F	25 V		
R1	Resistor	2 k Ω	1/4 W		
R2	Resistor	3.3 k Ω	1/4 W		
R3	Resistor	10 k Ω	1/4 W		
R4	Resistor	6.2 k Ω	1/4 W		
R5	Resistor	10 k Ω	1/4 W		
R6	Resistor	2.7 k Ω	1/4 W		
R7	Resistor	10 k Ω	1/4 W		

Notes : IR : International Rectifier Corp.

ROHM : Rohm, Ltd.

TDK : TDK, Ltd.

MB3885

■ REFERENCE DATA

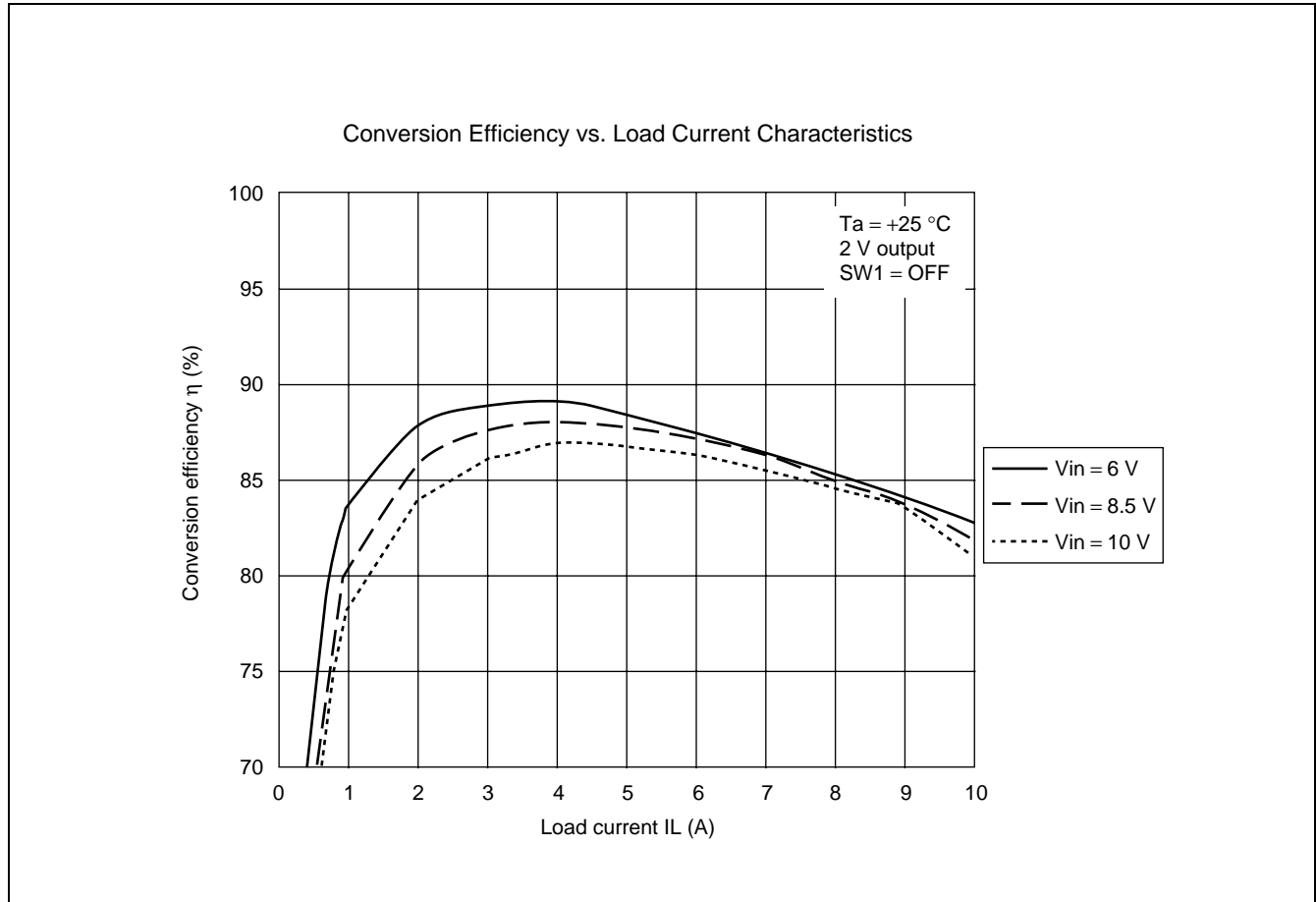

■ PRECAUTIONARY INFORMATION

- **Printed circuit board ground lines should be designed with consideration for common impedance.**
- **Take sufficient countermeasures should be taken to protect against static electricity.**
- Always place semiconductors in containers that have anti-static provisions, or are conductive.
- After mounting, PC boards should be placed in conductive bags or containers for storage and handling.
- Working surfaces, tools, and measurement equipment should be grounded.
- Persons handling semiconductors should be grounded directly with resistance of 250 k Ω to 1 M Ω .
- **Do not apply negative voltages.**
- Application of negative voltage of -0.3 V or greater can create parasitic transistor effects on an LSI device, leading to abnormal operation.

■ ORDERING INFORMATION

Part Number	Package	Remarks
MB3885PFV	Plastic SSOP 20-pin (FPT-20P-M03)	

MB3885

PACKAGE DIMENSION

20-pin, Plastic SSOP
(FPT-20P-M03)

* Dimensions include resin remainder.

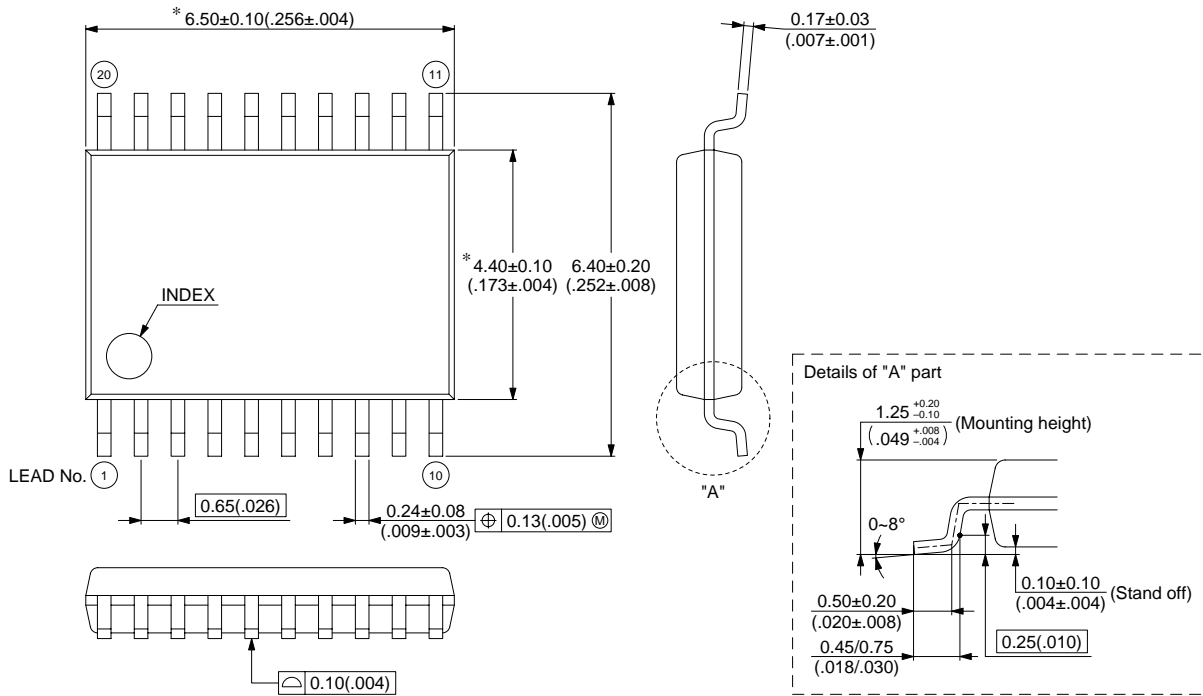

© 1999 FUJITSU LIMITED F20012S-3C-5

Dimensions in mm (inches)

FUJITSU LIMITED

For further information please contact:

Japan

FUJITSU LIMITED
Corporate Global Business Support Division
Electronic Devices
Shinjuku Dai-Ichi Seimei Bldg. 7-1,
Nishishinjuku 2-chome, Shinjuku-ku,
Tokyo 163-0721, Japan
Tel: +81-3-5322-3347
Fax: +81-3-5322-3386

<http://edevice.fujitsu.com/>

North and South America

FUJITSU MICROELECTRONICS, INC.
3545 North First Street,
San Jose, CA 95134-1804, U.S.A.
Tel: +1-408-922-9000
Fax: +1-408-922-9179

Customer Response Center
Mon. - Fri.: 7 am - 5 pm (PST)
Tel: +1-800-866-8608
Fax: +1-408-922-9179

<http://www.fujitsumicro.com/>

Europe

FUJITSU MICROELECTRONICS EUROPE GmbH
Am Siebenstein 6-10,
D-63303 Dreieich-Buchsschlag,
Germany
Tel: +49-6103-690-0
Fax: +49-6103-690-122

<http://www.fujitsu-fme.com/>

Asia Pacific

FUJITSU MICROELECTRONICS ASIA PTE. LTD.
#05-08, 151 Lorong Chuan,
New Tech Park,
Singapore 556741
Tel: +65-281-0770
Fax: +65-281-0220

<http://www.fmap.com.sg/>

Korea

FUJITSU MICROELECTRONICS KOREA LTD.
1702 KOSMO TOWER, 1002 Daechi-Dong,
Kangnam-Gu, Seoul 135-280
Korea
Tel: +82-2-3484-7100
Fax: +82-2-3484-7111

All Rights Reserved.

The contents of this document are subject to change without notice. Customers are advised to consult with FUJITSU sales representatives before ordering.

The information and circuit diagrams in this document are presented as examples of semiconductor device applications, and are not intended to be incorporated in devices for actual use. Also, FUJITSU is unable to assume responsibility for infringement of any patent rights or other rights of third parties arising from the use of this information or circuit diagrams.

The contents of this document may not be reproduced or copied without the permission of FUJITSU LIMITED.

FUJITSU semiconductor devices are intended for use in standard applications (computers, office automation and other office equipments, industrial, communications, and measurement equipments, personal or household devices, etc.).

CAUTION:

Customers considering the use of our products in special applications where failure or abnormal operation may directly affect human lives or cause physical injury or property damage, or where extremely high levels of reliability are demanded (such as aerospace systems, atomic energy controls, sea floor repeaters, vehicle operating controls, medical devices for life support, etc.) are requested to consult with FUJITSU sales representatives before such use. The company will not be responsible for damages arising from such use without prior approval.

Any semiconductor devices have inherently a certain rate of failure. You must protect against injury, damage or loss from such failures by incorporating safety design measures into your facility and equipment such as redundancy, fire protection, and prevention of over-current levels and other abnormal operating conditions.

If any products described in this document represent goods or technologies subject to certain restrictions on export under the Foreign Exchange and Foreign Trade Control Law of Japan, the prior authorization by Japanese government should be required for export of those products from Japan.