

ASSP For Video Applications

CMOS

8-bit 100 MSPS A/D Converter

MB40C328

DESCRIPTION

MB40C328 is a high-speed A/D converter using a fast CMOS technology.

FEATURES

- Resolution : 8 bit
- Linearity error : $\pm 0.40\%$ (standard)
- Maximum conversion rate : 100 MSPS (minimum)
- Power supply voltage : 3.3 V single (standard)
- Digital input/output voltage range : CMOS level compatible
- Analog input voltage range : 0 to 3.0 V (2 V_{p-p})
- Analog input capacitance : 22 pF (standard)
- Power dissipation : 210 mW (standard)
- Additional features : Reference voltage generator circuit: $V_{REFT} = 3.0\text{ V}$, $V_{REFB} = 1.0\text{ V}$
High impedance output, power down function
1:2 demultiplex output enable (RESET action enable)
1/2 deviding clock output
Cross sampling at 50 MHz (two-phase CLK) enable (CLKA, CLKB)
- Package : LQFP48 (7 mm \times 7 mm, lead pitch 0.5 mm)

PACKAGE

48-pin plastic LQFP

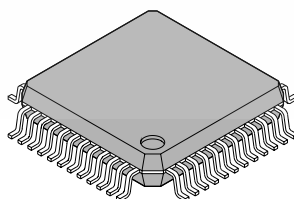

(FPT-48P-M05)

MB40C328

■ PIN ASSIGNMENT

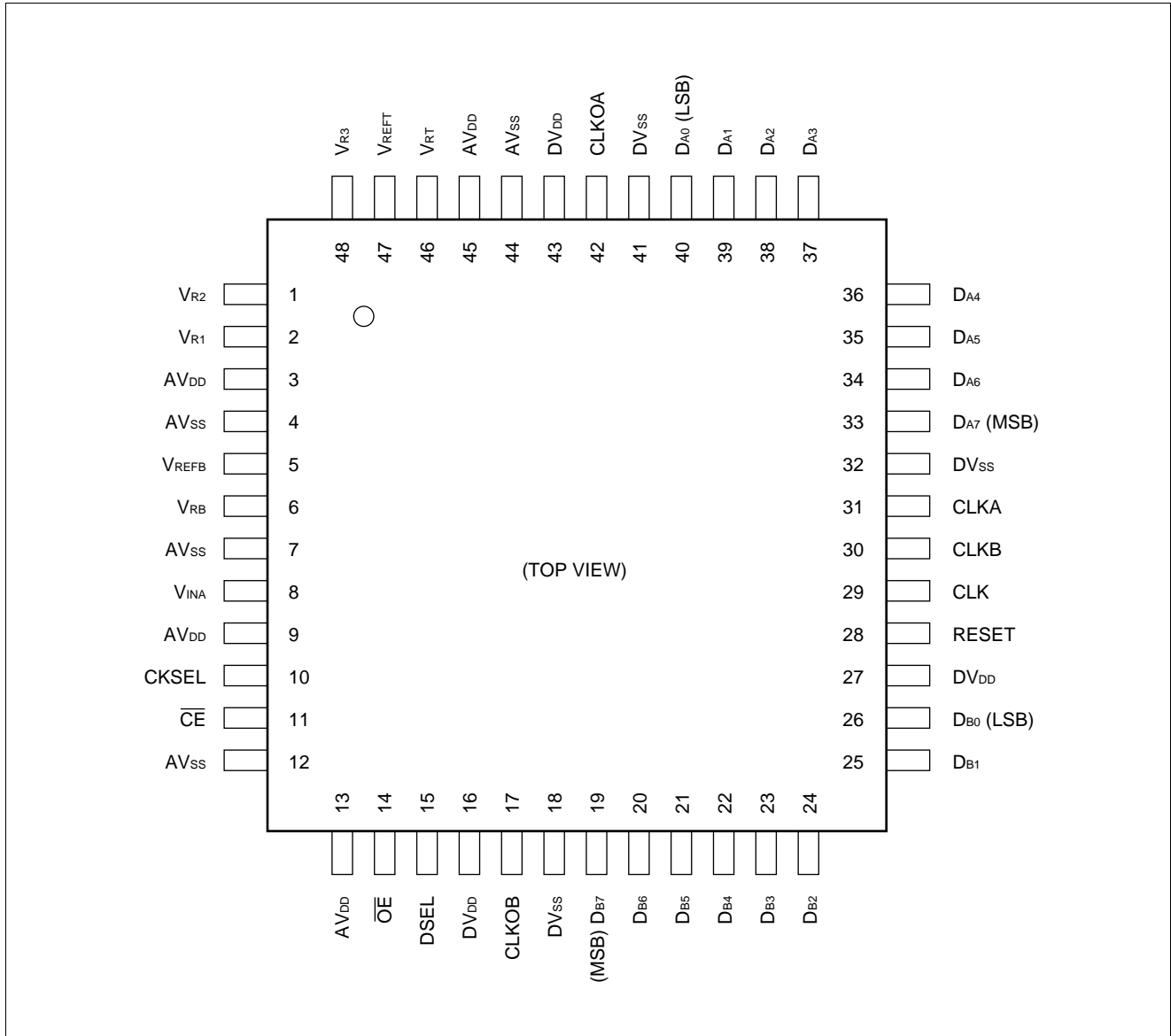

■ PIN DESCRIPTION

Pin No.	Symbol	Description
3, 9, 13, 45	AV _{DD}	Analog power supply (+3.3 V)
16, 27, 43	DV _{DD}	Digital power supply (+3.3 V)
4, 7, 12, 44	AV _{SS}	Analog power supply ground pin (0 V)
18, 32, 41	DV _{SS}	Digital power supply ground pin (0 V)
33 to 40	D _{A7} to D _{A0}	Digital output pin (Port A) D _{A7} : MSB, D _{A0} : LSB
19 to 26	D _{B7} to D _{B0}	Digital output pin (Port B) D _{B7} : MSB, D _{B0} : LSB
11	\overline{CE}	Power down at \overline{CE} input "H" (internal pull-up resistor)
14	\overline{OE}	Digital output (Both Port A, B) and clock output (CLKOA, CLKOB) are high impedance at \overline{OE} input "H".
10	CKSEL	Mode of operation setting input pin (Refer to ■ MODE SETTING)
15	DSEL	
28	RESET	Dividing circuit reset input pin (See ■ TIMING CHART 2, 3)
29	CLK	Clock input pin (max 100 MHz)
31	CLKA	A ch clock input pin (max 50 MHz)
30	CLKB	B ch clock input pin (max 50 MHz)
42	CLKOA	Clock output pin (See ■ TIMING CHART 1 to 4)
17	CLKOB	Clock output pin (See ■ TIMING CHART 1 to 4)
8	V _{INA}	Analog input pin Input range is V _{RT} to V _{RB} (0 V to 3.0 V: 2 V _{p-p})
2	V _{R1}	Reference 1/4 voltage output pin (Add 0.1 μF for AV _{SS}) Reference 1/2 voltage output pin (Add 0.1 μF for AV _{SS}) Reference 3/4 voltage output pin (Add 0.1 μF for AV _{SS})
1	V _{R2}	
48	V _{R3}	
46	V _{RT}	Reference voltage input pin on top side
47	V _{REFT}	Reference voltage output pin By connecting to V _{RT} , 0.9 × AV _{DD} (≒ 3 V) is generated.
6	V _{RB}	Reference voltage input pin on bottom side
5	V _{REFB}	Reference voltage output pin By connecting to V _{RB} , 0.3 × AV _{DD} (≒ 1 V) is generated.

The values in parentheses are standard.

■ PRECAUTIONS ON USE

- Be sure to ground the pins of AV_{DD}, DV_{DD}, V_{RT}, V_{RB}, V_{R1}, V_{R2}, and V_{R3} via high-frequency capacitor. Place the high-frequency capacitor as close as possible to the pin.
- To avoid generation of undesired current owing to indetermination of internal logic, set \overline{CE} to "H" at powering on and input more than five clock pulses just after operation (\overline{CE} : "H" → "L").

MB40C328

■ BLOCK DIAGRAM

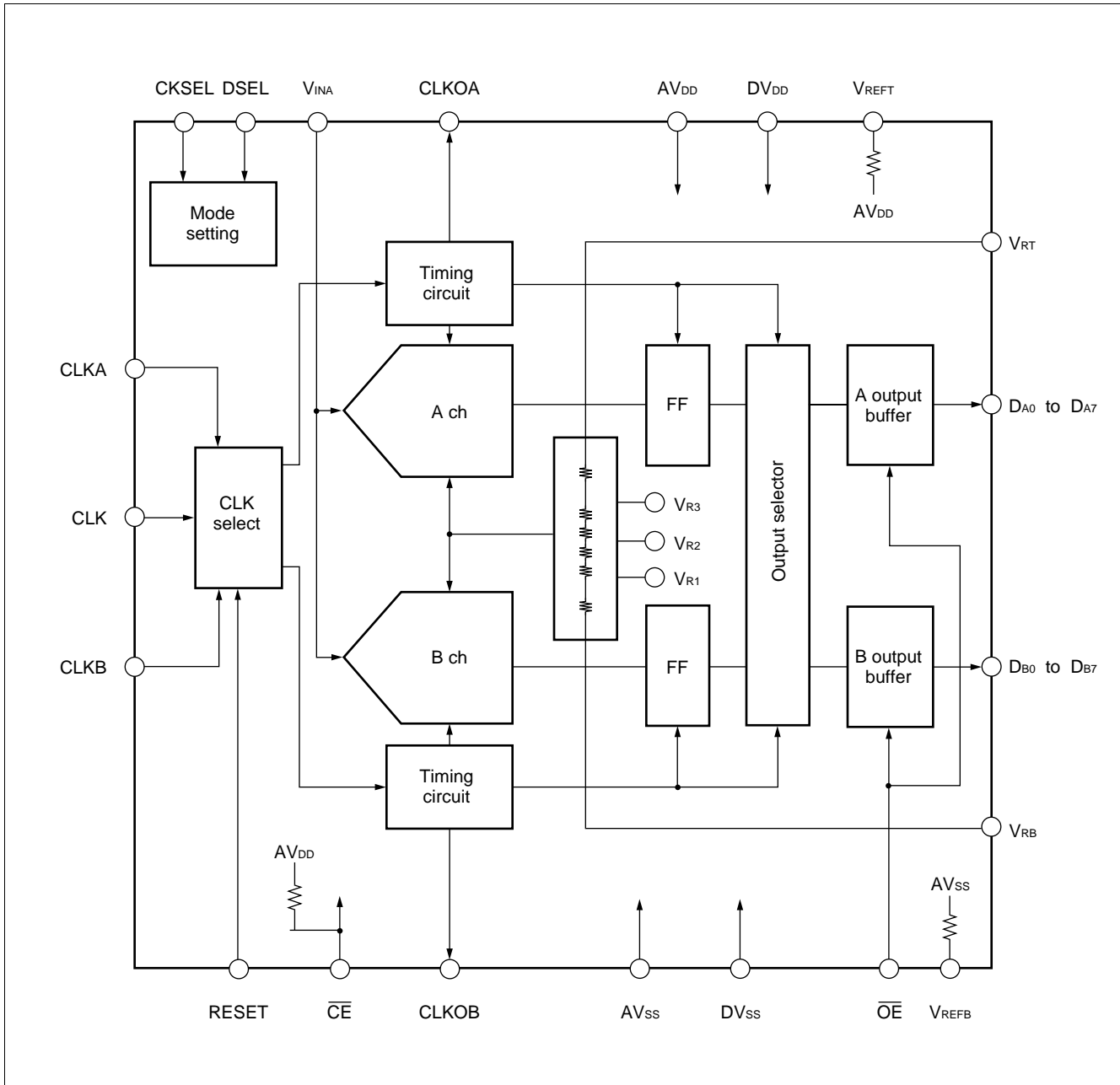

■ ABSOLUTE MAXIMUM RATINGS

Parameter	Symbol	Rating		Unit
		Min.	Max.	
Power supply voltage	AV_{DD}, DV_{DD}	-0.3	+4.0	V
Input/output voltage	$V_{INA}, V_{RT}, V_{RB}, V_{REFT}, V_{REFB}, V_{R1}, V_{R2}, V_{R3}, \overline{CE}, CKSEL$	-0.3	$AV_{DD}+0.3^*$	V
	DA_0 to DA_7, DB_0 to $DB_7, CLKOA, CLKOB, CLKA, CLKB, CLK, DSEL, \overline{OE}, RESET$	-0.3	$DV_{DD}+0.3^*$	V
Storage temperature	T_{STG}	-55	+125	°C

* : Do not exceed +4.0 V.

WARNING: Semiconductor devices can be permanently damaged by application of stress (voltage, current, temperature, etc.) in excess of absolute maximum ratings. Do not exceed these ratings.

MB40C328

■ RECOMMENDED OPERATING CONDITIONS

Parameter	Symbol	Value			Unit
		Min.	Typ.	Max.	
Power supply voltage	AV_{DD}, DV_{DD}	3.00	3.30	3.60	V
Analog input voltage	V_{INA}	V_{RB}	—	V_{RT}	V
Analog reference voltage: T	V_{RT}	—	—	3.00	V
Analog reference voltage: B	V_{RB}	0.00	—	—	V
Analog reference voltage range	$V_{RT} - V_{RB}$	1.90	2.00	2.10	V
Digital "H" level input voltage	$\overline{OE}, DSEL, RESET, CLK, CLKA, CLKB$	$DV_{DD} - 0.5$	—	—	V
	$CKSEL, \overline{CE}$	$AV_{DD} - 0.5$	—	—	V
Digital "L" level input voltage	$\overline{OE}, DSEL, RESET, CLK, CLKA, CLKB$	—	—	0.5	V
	$CKSEL, \overline{CE}$	—	—	0.5	V
Digital input current	I_{ID}	-20	—	5	μA
Single-phase clock frequency	f_{CLK}	0.1	—	100	MHz
Two-phase clock frequency	f_{CLKA}, f_{CLKB}	0.1	—	50	MHz
Minimum clock pulse width (single-phase)	t_{WS}^+, t_{WS}^-	4.0	5.0	—	ns
Minimum clock pulse width (two-phase)	t_{WD}^+, t_{WD}^-	8.0	10.0	—	ns
Clock pulse rising/falling time	t_r, t_f	—	2.0	—	ns
RESET signal setup time	t_s	3.0	—	—	ns
RESET signal hold time	t_h	3.0	—	—	ns
Operating temperature range	T_a	-20	—	70	$^{\circ}C$

WARNING: The recommended operating conditions are required in order to ensure the normal operation of the semiconductor device. All of the device's electrical characteristics are warranted when the device is operated within these ranges.

Always use semiconductor devices within their recommended operating condition ranges. Operation outside these ranges may adversely affect reliability and could result in device failure.

No warranty is made with respect to uses, operating conditions, or combinations not represented on the data sheet. Users considering application outside the listed conditions are advised to contact their FUJITSU representatives beforehand.

■ ELECTRICAL CHARACTERISTICS

• DC Characteristics in Analog Section

($AV_{DD} = DV_{DD} = 3.00\text{ V to }3.60\text{ V}$, $T_a = -20^{\circ}\text{C to }+70^{\circ}\text{C}$)

Parameter	Symbol	Value			Unit
		Min.	Typ.	Max.	
Resolution	—	—	8	—	bit
Linearity error	LE	—	± 0.40	± 0.6	%
Differential linearity error	DLE	—	± 0.20	± 0.36	%
Analog input capacity	C_{INA}	—	22	—	pF
Reference voltage: T	V_{REFT}	$0.88 \times AV_{DD}$	$0.91 \times AV_{DD}$	$0.94 \times AV_{DD}$	V
Reference voltage: B	V_{REFB}	$0.27 \times AV_{DD}$	$0.3 \times AV_{DD}$	$0.33 \times AV_{DD}$	V
Reference current	I_{RB}	-15	-10	—	mA
Analog supply current	I_{DD}	—	42.0	85.0	mA
Digital supply current	I_{DD}	—	20.0	40.0	mA
Standby current	I_{SB}	—	100	—	mA

• DC Characteristics in Digital Section

($AV_{DD} = DV_{DD} = 3.00\text{ V to }3.60\text{ V}$, $T_a = -20^{\circ}\text{C to }+70^{\circ}\text{C}$)

Parameter	Symbol	Value			Unit
		Min.	Typ.	Max.	
Digital "H" level output voltage	V_{OHD}	$DV_{DD} - 0.4$	—	DV_{DD}	V
Digital "L" level output voltage	V_{OLD}	—	—	0.4	V
Digital "H" level output current	I_{OHD}	-400	—	—	μA
Digital "L" level output current	I_{OLD}	—	—	1.6	mA

MB40C328

• Switching Characteristics

($AV_{DD} = DV_{DD} = 3.00\text{ V to }3.60\text{ V}$, $T_a = -20^\circ\text{C to }+70^\circ\text{C}$)

Parameter	Symbol	Value			Unit	
		Min.	Typ.	Max.		
Maximum conversion rate	f_s	100	—	—	MSPS	
Aperture time	t_{AD}	—	1.7	—	ns	
Digital output delay time	Timing chart 1	t_{pdS}	2.5	6.0	9.0	ns
		t_{pdSO}	$t_{ws}^+ + 2.5$	$t_{ws}^+ + 6.0$	$t_{ws}^+ + 10$	ns
	Timing chart 2	t_{pdM1}	2.5	5.5	10	ns
		t_{pdM1O}	$T + 2.5$	$T + 5.5$	$T + 10$	ns
	Timing chart 3	t_{pdM2}	2.5	5.5	10	ns
		t_{pdM2O}	$T + 2.5$	$T + 5.5$	$T + 10$	ns
	Timing chart 4	t_{pdD}	2.5	6.5	11	ns
		t_{pdDO}	$t_{wD}^+ + 2.5$	$t_{wD}^+ + 6.5$	$t_{wD}^+ + 11$	ns

■ DIGITAL OUTPUT BUFFER LOAD CIRCUIT

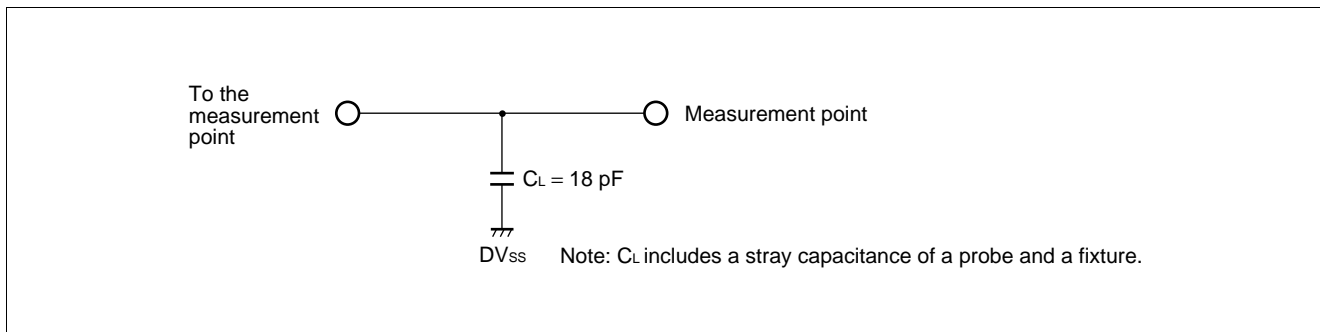

■ MODE SETTING

CKCEL	DCEL	Mode	Timing Chart
H	H	CLK input-straight output mode	Timing chart 1
H	L	CLK input-demultiplex output (in-phase) mode	Timing chart 2
L	H	CLK input-demultiplex output (two-phase) mode	Timing chart 3
L	L	Two-phase CLK input mode (CLKA, CLKB)	Timing chart 4

■ TIMING CHART 1

CLK input-straight output mode

- CLK = 100 MHz (max)
- CLKA = CLKB = "L" (DV_{SS})
- CKSEL = "H" (AV_{DD})
- DSEL = "H" (DV_{DD})
- RESET = "H" (DV_{DD})
- \overline{CE} = "L" (AV_{SS})
- \overline{OE} = "L" (DV_{SS})

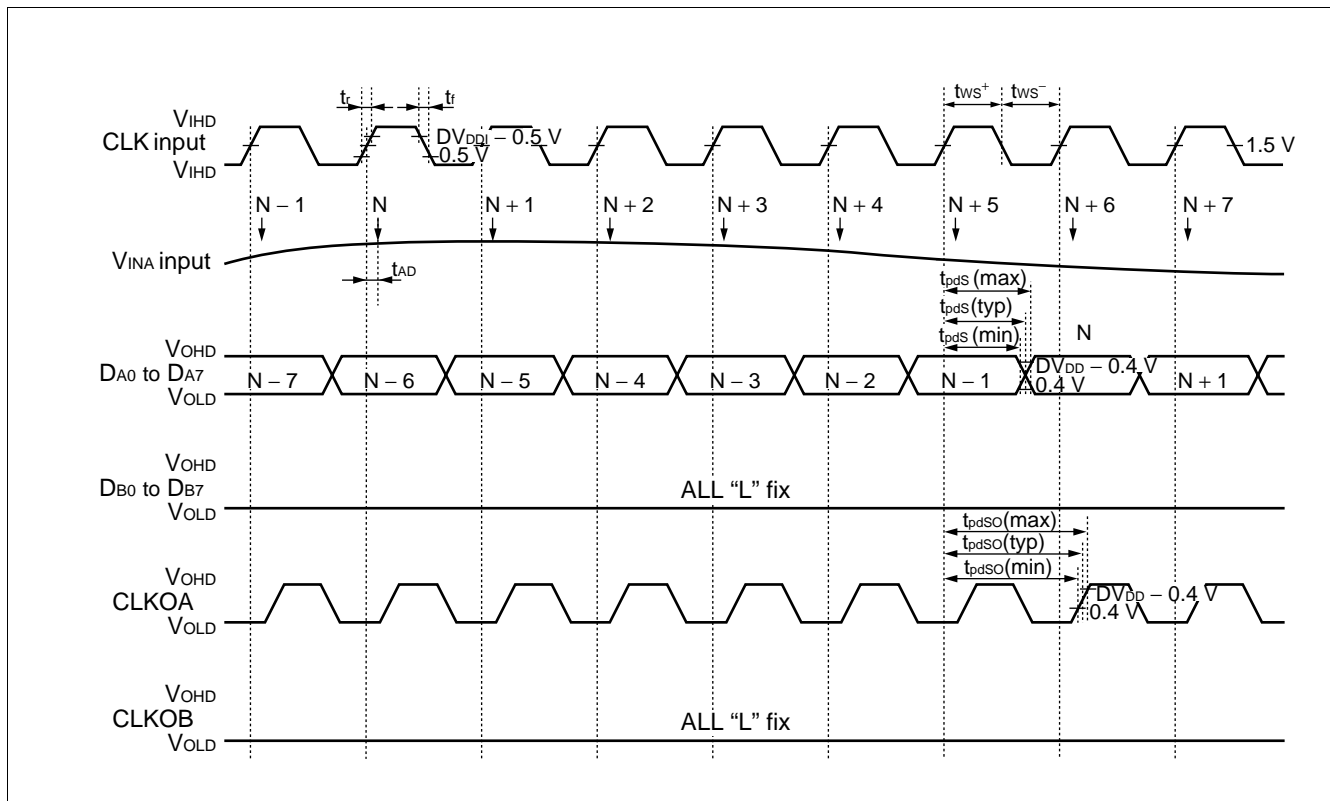

- V_{INA} input — Sampling at CLK rising
- DA₀ to DA₇ — Output (after 5 CLK + t_{pds} from Sampling) at CLK rising

MB40C328

■ TIMING CHART 2

CLK input-demultiplex output (in-phase) mode

- CLK = 100 MHz (max)
- CLKA = CLKB = "L" (DV_{SS})
- CKSEL = "H" (AV_{DD})
- DSEL = "L" (DV_{SS})
- $\overline{\text{CE}}$ = "L" (AV_{SS})
- $\overline{\text{OE}}$ = "L" (DV_{SS})

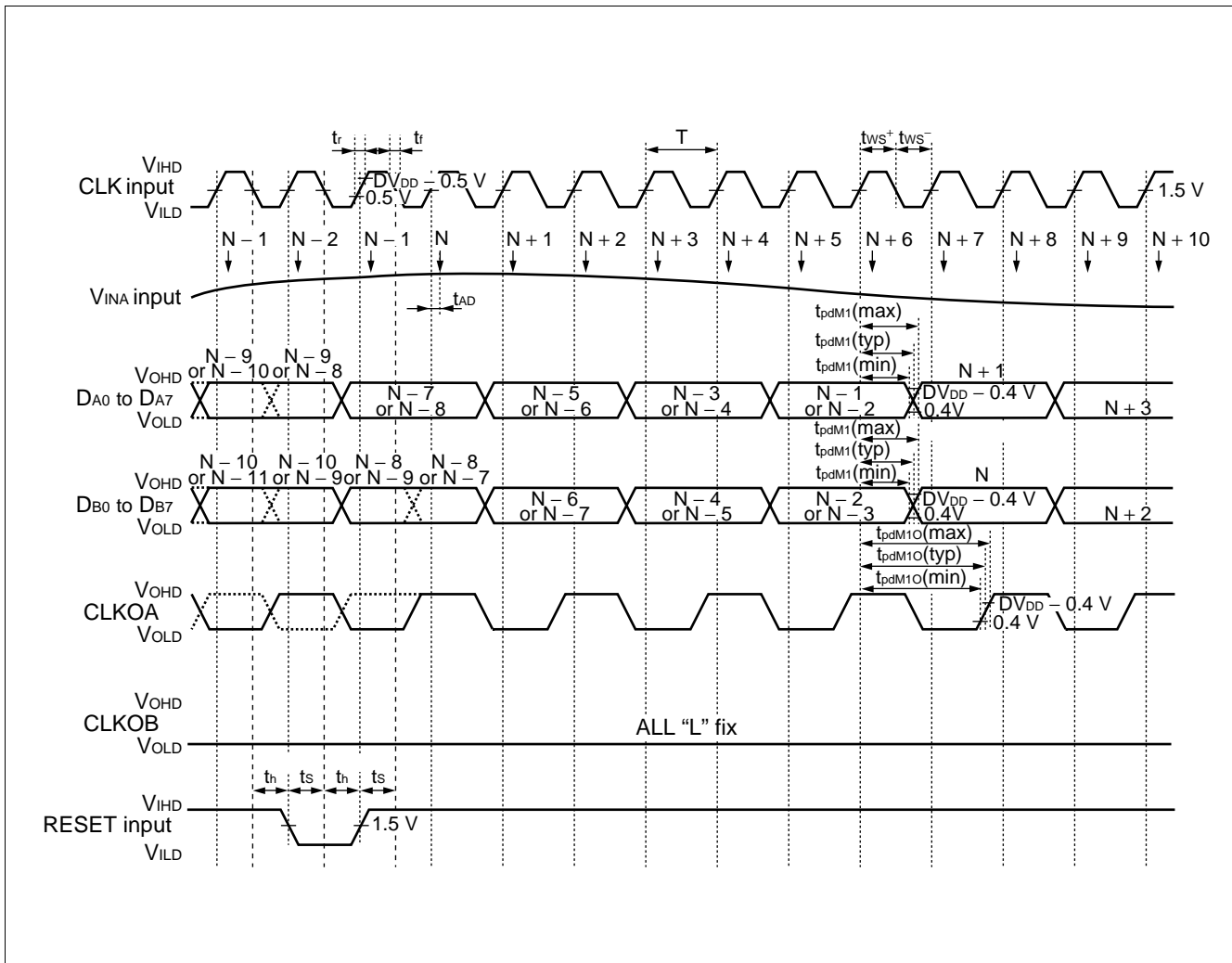

- V_{INA} input — Sampling at CLK rising
- DA_0 to DA_7 — Output (after 5 CLK + t_{pdM1} from Sampling) at CLK rising
- DB_0 to DB_7 — Output (after 6 CLK + t_{pdM1} from Sampling) at CLK rising

TIMING CHART 3

CLK input-demultiplex output (two-phase) mode

- CLK = 100 MHz (max)
- CLKA = CLKB = "L" (DV_{SS})
- CKSEL = "L" (AV_{SS})
- DSEL = "H" (DV_{DD})
- \overline{CE} = "L" (AV_{SS})
- \overline{OE} = "L" (DV_{SS})

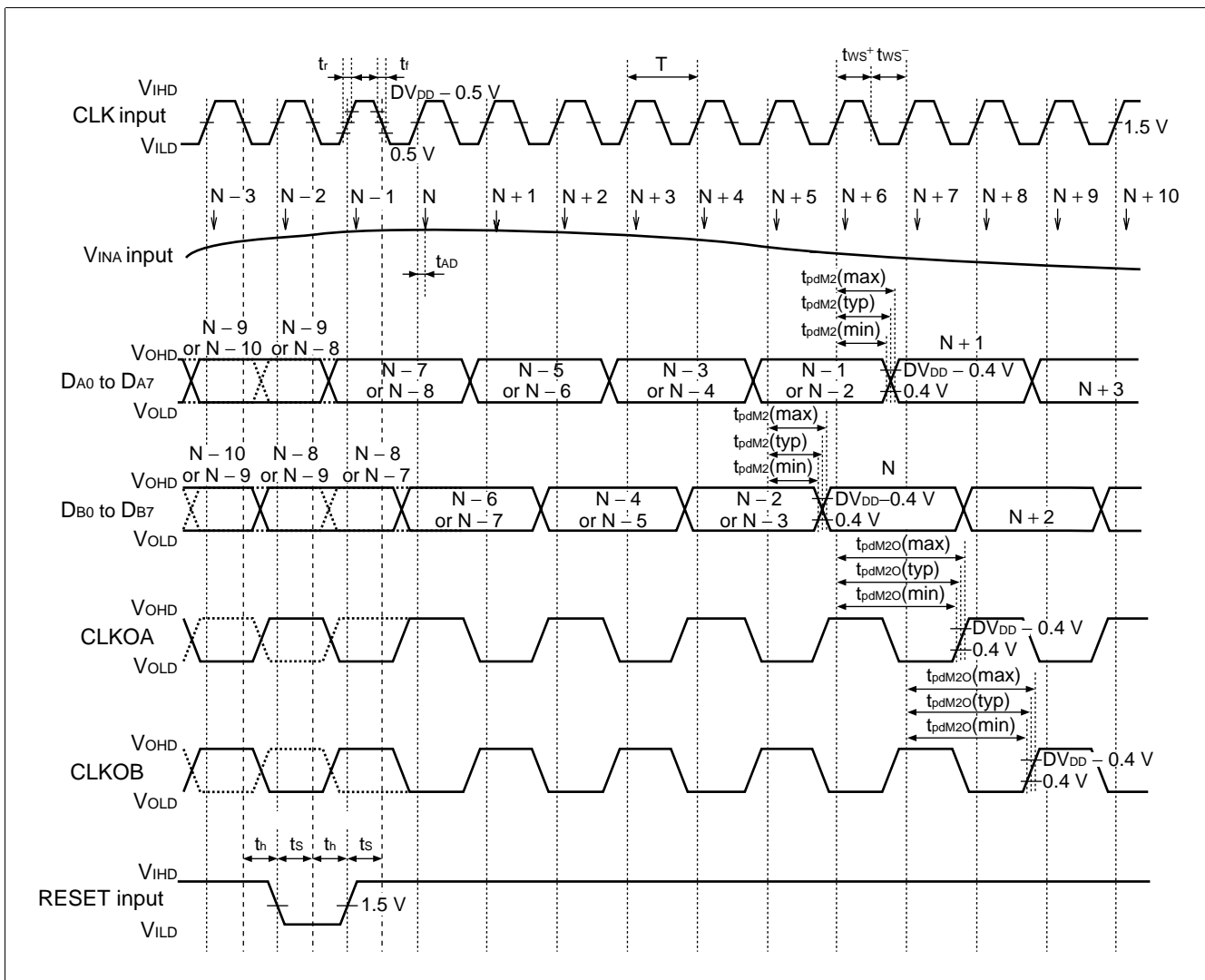

- V_{INA} input — Sampling at CLK rising
- DA₀ to DA₇ — Output (after 5 CLK + t_{pdM2} from Sampling) at CLK rising
- DB₀ to DB₇ — Output (after 5 CLK + t_{pdM2} from Sampling) at CLK rising

MB40C328

■ TIMING CHART 4

Two-phase CLK input mode (CLKA, CLKB)

- CLK = "L" (DV_{SS}) or "H" (DV_{DD})
- CLKA = CLKB = 50 MHz (max)
- CKSEL = "L" (AV_{SS})
- DSEL = "L" (DV_{SS})
- RESET = "H" (DV_{DD}) or "L" (DV_{SS})
- \overline{CE} = "L" (AV_{SS})
- \overline{OE} = "L" (DV_{SS})

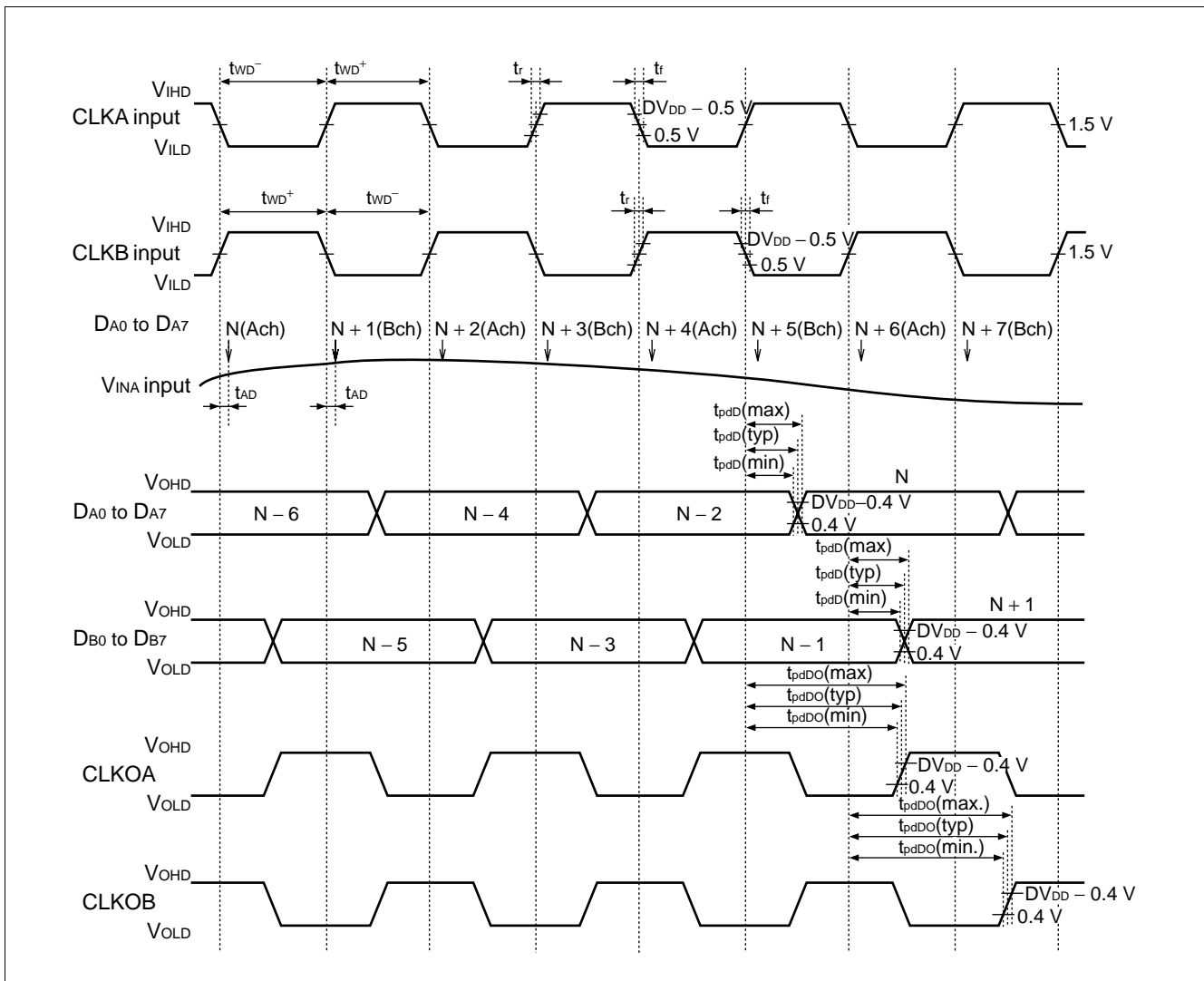

- V_{INA} input — Sampling (A ch) at CLKA falling
Sampling (B ch) at CLKB falling
- DA0 to DA7 — Output (after 2.5 CLK + t_{pdD} from Sampling) at CLKA rising
- DB0 to DB7 — Output (after 2.5 CLK + t_{pdD} from Sampling) at CLKB rising

■ TYPICAL CONNECTION EXAMPLE

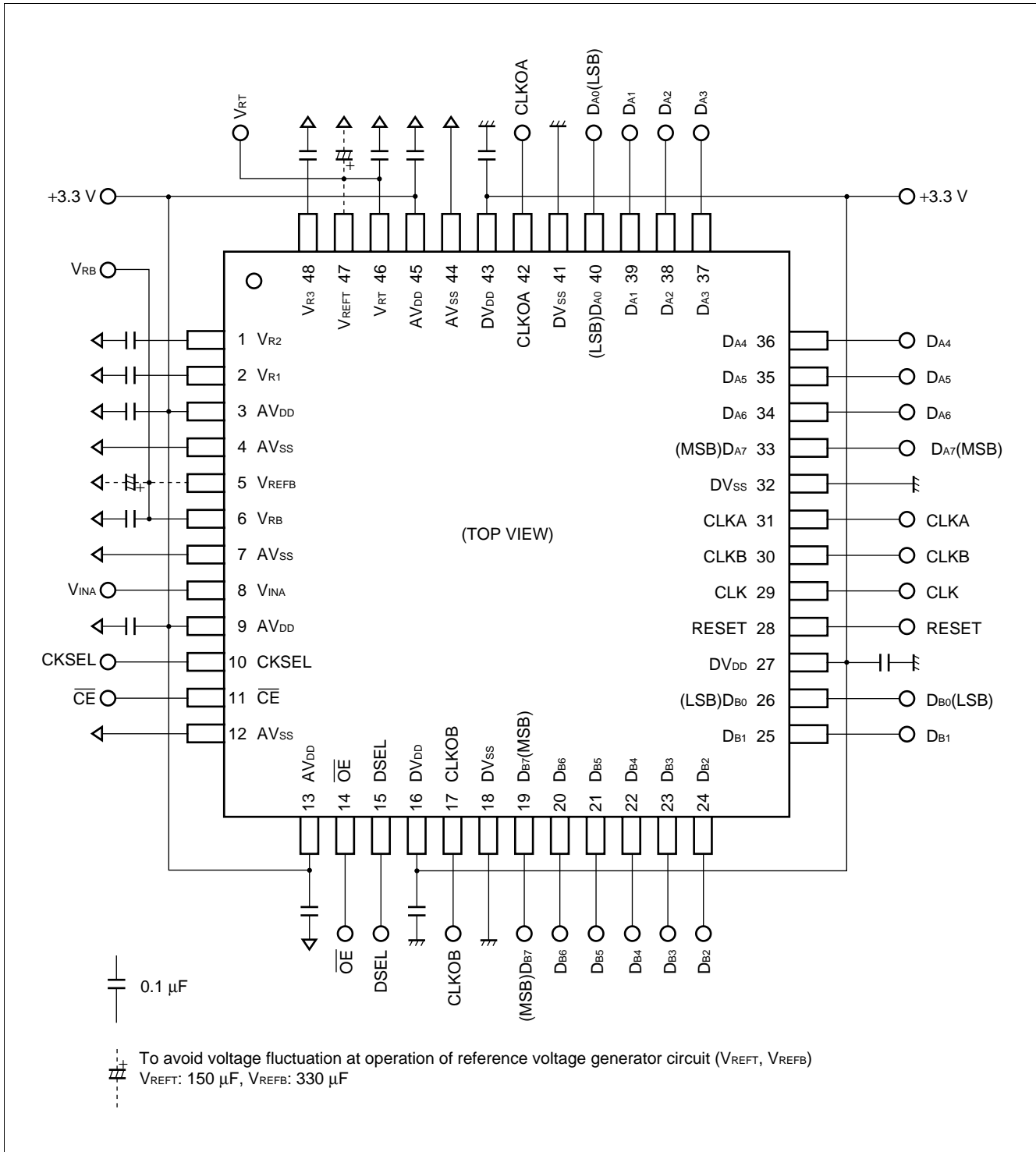

MB40C328

■ ORDERING INFORMATION

Part number	Package	Remark
MB40C328PFV	48-pin Plastic LQFP (FPT-48P-M05)	

■ PACKAGE DIMENSION

48-pin Plastic LQFP
(FPT-48P-M05)

Note) Pins width and pins thickness include plating thickness.

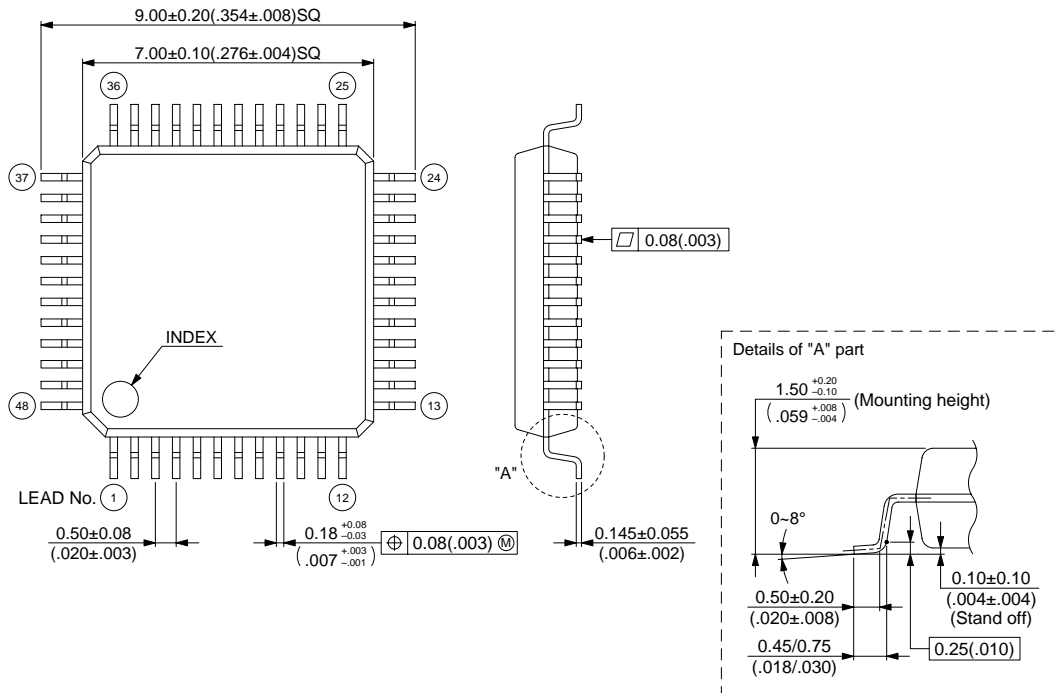

MB40C328

FUJITSU LIMITED

For further information please contact:

Japan

FUJITSU LIMITED
Corporate Global Business Support Division
Electronic Devices
KAWASAKI PLANT, 4-1-1, Kamikodanaka,
Nakahara-ku, Kawasaki-shi,
Kanagawa 211-8588, Japan
Tel: +81-44-754-3763
Fax: +81-44-754-3329

<http://www.fujitsu.co.jp/>

North and South America

FUJITSU MICROELECTRONICS, INC.
3545 North First Street,
San Jose, CA 95134-1804, USA
Tel: +1-408-922-9000
Fax: +1-408-922-9179

Customer Response Center
Mon. - Fri.: 7 am - 5 pm (PST)
Tel: +1-800-866-8608
Fax: +1-408-922-9179

<http://www.fujitsumicro.com/>

Europe

FUJITSU MICROELECTRONICS EUROPE GmbH
Am Siebenstein 6-10,
D-63303 Dreieich-Buchsschlag,
Germany
Tel: +49-6103-690-0
Fax: +49-6103-690-122

<http://www.fujitsu-fme.com/>

Asia Pacific

FUJITSU MICROELECTRONICS ASIA PTE LTD
#05-08, 151 Lorong Chuan,
New Tech Park,
Singapore 556741
Tel: +65-281-0770
Fax: +65-281-0220

<http://www.fmap.com.sg/>

F0001

© FUJITSU LIMITED Printed in Japan

All Rights Reserved.

The contents of this document are subject to change without notice.

Customers are advised to consult with FUJITSU sales representatives before ordering.

The information and circuit diagrams in this document are presented as examples of semiconductor device applications, and are not intended to be incorporated in devices for actual use. Also, FUJITSU is unable to assume responsibility for infringement of any patent rights or other rights of third parties arising from the use of this information or circuit diagrams.

The contents of this document may not be reproduced or copied without the permission of FUJITSU LIMITED.

FUJITSU semiconductor devices are intended for use in standard applications (computers, office automation and other office equipments, industrial, communications, and measurement equipments, personal or household devices, etc.).
CAUTION:

Customers considering the use of our products in special applications where failure or abnormal operation may directly affect human lives or cause physical injury or property damage, or where extremely high levels of reliability are demanded (such as aerospace systems, atomic energy controls, sea floor repeaters, vehicle operating controls, medical devices for life support, etc.) are requested to consult with FUJITSU sales representatives before such use. The company will not be responsible for damages arising from such use without prior approval.

Any semiconductor devices have inherently a certain rate of failure. You must protect against injury, damage or loss from such failures by incorporating safety design measures into your facility and equipment such as redundancy, fire protection, and prevention of over-current levels and other abnormal operating conditions.

If any products described in this document represent goods or technologies subject to certain restrictions on export under the Foreign Exchange and Foreign Trade Control Law of Japan, the prior authorization by Japanese government should be required for export of those products from Japan.