

# MEMORY

CMOS

## 8 x 256K x 32 BIT, FCRAM™ CORE BASED DOUBLE DATA RATE SDRAM

### MB81P643287-50/-60

CMOS 8-BANK x 262,144-WORD x 32 BIT, FCRAM Core Based  
Synchronous Dynamic Random Access Memory  
with Double Data Rate

#### DESCRIPTION

The Fujitsu MB81P643287 is a CMOS Synchronous Dynamic Random Access Memory (SDRAM) with Fujitsu advanced FCRAM (Fast Cycle Random Access Memory) Core Technology, containing 67,108,864 memory cells accessible in an 32-bit format. The MB81P643287 features a fully synchronous operation referenced to clock edge whereby all operations are synchronized at a clock input which enables high performance and simple user interface coexistence. The MB81P643287 is designed to reduce the complexity of using a standard dynamic RAM (DRAM) which requires many control signal timing constraints. The MB81P643287 uses Double Data Rate (DDR) where data bandwidth is twice of fast speed compared with regular SDRAMs.

The MB81P643287 is ideally suited for Digital Visual Systems, High Performance Graphic Adapters, Hardware Accelerators, Buffers, and other applications where large memory density and high effective bandwidth are required and where a simple interface is needed.

The MB81P643287 adopts new I/O interface circuitry, SSTL\_2 interface, which is capable of extremely fast data transfer of quality under either terminated or point to point bus environment.

#### PRODUCT LINE

Parameter		MB81P643287	
		-50	-60
Clock Frequency	CL = 3	200 MHz Max.	167 MHz Max.
	CL = 2	133 MHz Max.	111 MHz Max.
Burst Mode Cycle Time	CL = 3	2.5 ns Min.	3.0 ns Min.
	CL = 2	3.75 ns Min.	4.5 ns Min.
Random Address Cycle Time		30 ns Min.	36 ns Min.
DQS Access Time From Clock		0.1 × t <sub>clk</sub> + 0.2 ns Max.	0.1 × t <sub>clk</sub> + 0.2 ns Max.
Operating Current		460 mA Max.	405 mA Max.
Power Down Current		35 mA Max.	

Note: FCRAM is a trademark of Fujitsu Limited, Japan.

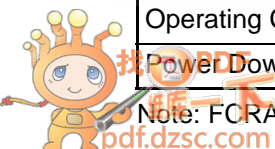

# MB81P643287-50/-60

## ■ FEATURES

- Double Data Rate
- Bi-directional Data Strobe Signal
- Eight bank operation
- Burst read/write operation
- Programmable burst length and CAS latency
- Byte write control by DM<sub>0</sub> to DM<sub>3</sub>
- Standby Power Down Mode
- 4096 Auto-refresh cycles in 32 ms
- SSTL\_2 (class 2) for all signals
- V<sub>DD</sub>: +2.5V Supply ± 0.2V tolerance
- V<sub>DDQ</sub>: +2.5V Supply ± 0.2V tolerance

## ■ PACKAGE

86-pin plastic TSOP(II)

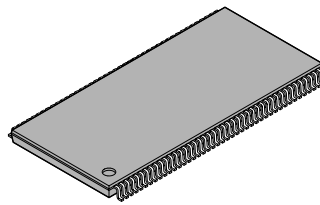

(FPT-86P-M01)  
(Normal Bend)

# MB81P643287-50/-60

## ■ PIN ASSIGNMENTS

86-pin TSOP (II)  
(TOP VIEW)  
(Normal Bend)

VDD	1	86	Vss
DQ0	2	85	DQ15
VDDQ	3	84	VSSQ
DQ1	4	83	DQ14
DQ2	5	82	DQ13
VSSQ	6	81	VDDQ
DQ3	7	80	DQ12
DQ4	8	79	DQ11
VDDQ	9	78	VSSQ
DQ5	10	77	DQ10
DQ6	11	76	DQ9
VSSQ	12	75	VDDQ
DQ7	13	74	DQ8
DQS0	14	73	DQS1
VDD	15	72	Vss
DM0	16	71	DM1
WE	17	70	VREF
CAS	18	69	CLK
RAS	19	68	CLK
CS	20	67	CKE
BA2	21	66	A9
BA0	22	65	A8
BA1	23	64	A7
A10/AP	24	63	A6
A0	25	62	A5
A1	26	61	A4
A2	27	60	A3
DM2	28	59	DM3
VDD	29	58	Vss
DQS2	30	57	DQS3
DQ16	31	56	DQ31
VSSQ	32	55	VDDQ
DQ17	33	54	DQ30
DQ18	34	53	DQ29
VDDQ	35	52	VSSQ
DQ19	36	51	DQ28
DQ20	37	50	DQ27
VSSQ	38	49	VDDQ
DQ21	39	48	DQ26
DQ22	40	47	DQ25
VDDQ	41	46	VSSQ
DQ23	42	45	DQ24
VDD	43	44	Vss

(FPT-86P-M01)

# MB81P643287-50/-60

## ■ DESCRIPTIONS

Pin Number	Symbol	Function
1, 3, 9, 15, 29, 35, 41, 43, 49, 55, 75, 81	$V_{DD}, V_{DDQ}$	Supply Voltage
6, 12, 32, 38, 44, 46, 52, 58, 72, 78, 84, 86	$V_{SS}, V_{SSQ}$	Ground
2, 4, 5, 7, 8, 10, 11, 13, 31, 33, 34, 36, 37, 39, 40, 42, 45, 47, 48, 50, 51, 53, 54, 56, 74, 76, 77, 79, 80, 82, 83, 85	$DQ_0$ to $DQ_{31}$	Data I/O <ul style="list-style-type: none"> <li>• Byte 0: <math>DQ_0</math> to <math>DQ_7</math></li> <li>• Byte 1: <math>DQ_8</math> to <math>DQ_{15}</math></li> <li>• Byte 2: <math>DQ_{16}</math> to <math>DQ_{23}</math></li> <li>• Byte 3: <math>DQ_{24}</math> to <math>DQ_{31}</math></li> </ul>
14, 30, 57, 73	$DQS_0$ to $DQS_3$	Data Strobe <ul style="list-style-type: none"> <li>• <math>DQS_0</math>: for <math>DQ_0</math> to <math>DQ_7</math></li> <li>• <math>DQS_1</math>: for <math>DQ_8</math> to <math>DQ_{15}</math></li> <li>• <math>DQS_2</math>: for <math>DQ_{16}</math> to <math>DQ_{23}</math></li> <li>• <math>DQS_3</math>: for <math>DQ_{24}</math> to <math>DQ_{31}</math></li> </ul>
16, 28, 59, 71	$DM_0$ to $DM_3$	Input Mask
17	$\overline{WE}$	Write Enable
18	$\overline{CAS}$	Column Address Strobe
19	$\overline{RAS}$	Row Address Strobe
20	$\overline{CS}$	Chip Select
21, 22, 23	$BA_2, BA_1, BA_0$	Bank Select (Bank Address)
24	AP	Auto Precharge Enable
24, 25, 26, 27, 60, 61, 62, 63, 64, 65, 66	$A_0$ to $A_{10}$	Address Input <ul style="list-style-type: none"> <li>• Row: <math>A_0</math> to <math>A_{10}</math></li> <li>• Column: <math>A_0</math> to <math>A_6</math></li> </ul>
67	CKE	Power Down
68	CLK	Clock Input
69	$\overline{CLK}$	Clock Input
70	$V_{REF}$	Input Reference Voltage

# MB81P643287-50/-60

## ■ BLOCK DIAGRAM

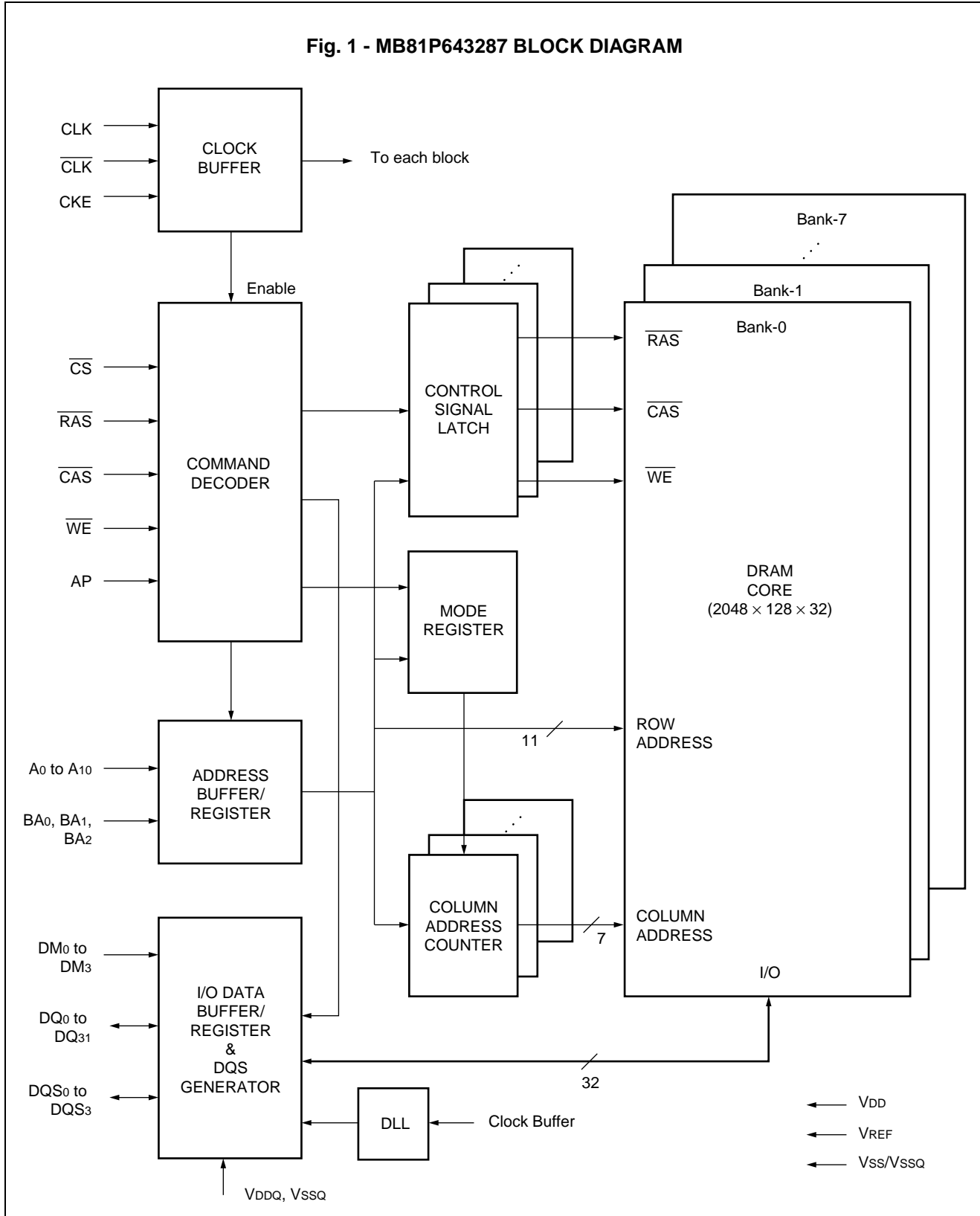

# MB81P643287-50/-60

## ■ FUNCTION TRUTH TABLE (Note\*1)

### COMMAND TRUTH TABLE (Note \*2, and \*3)

Function	Notes	Symbol	CKE	$\overline{CS}$	$\overline{RAS}$	$\overline{CAS}$	$\overline{WE}$	BA <sub>2-0</sub>	A <sub>10/AP</sub>	A <sub>9-7</sub>	A <sub>6-0</sub>
Device Deselect	*4	DESL	H	H	X	X	X	X	X	X	X
No Operation	*4	NOP	H	L	H	H	H	X	X	X	X
Burst Stop	*5	BST	H	L	H	H	L	X	X	X	X
Read	*6	READ	H	L	H	L	H	V	L	X	V
Read with Auto-precharge	*6	READA	H	L	H	L	H	V	H	X	V
Write	*6	WRIT	H	L	H	L	L	V	L	X	V
Write with Auto-precharge	*6	WRITA	H	L	H	L	L	V	H	X	V
Bank Active ( $\overline{RAS}$ )	*7	ACTV	H	L	L	H	H	V	V	V	V
Precharge Single Bank	*8	PRE	H	L	L	H	L	V	L	X	X
Precharge All Banks	*8	PALL	H	L	L	H	L	V	H	X	X
Mode Register Set/ Extended Mode Register Set	*8,9,10	MRS/ EMRS	H	L	L	L	L	V	L	V	V

Notes: \*1. V = Valid, L = Logic Low, H = Logic High, X = either L or H, Hi-Z = High Impedance.

\*2. All commands are assumed to be valid state transitions.

\*3. All inputs for command are latched on the rising edge of clock(CLK).

\*4. NOP and DESL commands have the same effect on the part.

Unless specifically noted, NOP will represent both NOP and DESL command in later descriptions.

\*5. BST is effective after READ command is issued.

\*6. READ, READA, WRIT and WRITA commands should only be issued after the corresponding bank has been activated (ACTV command). Refer to "■ STATE DIAGRAM".

\*7. ACTV command should only be issued after corresponding bank has been page closed by PRE or PALL command.

\*8. Either PRE or PALL command and MRS or EMRS command are required after power up.

\*9. MRS or EMRS command should only be issued after all banks have been page closed (PRE or PALL command), and DQs are in Hi-Z. Refer to "■ STATE DIAGRAM".

\*10. Refer to "■ MODE REGISTER TABLE".

# MB81P643287-50/-60

**DM TRUTH TABLE (Effective during Write mode)**

Function	Command	CKE		DM <sub>0</sub>	DM <sub>1</sub>	DM <sub>2</sub>	DM <sub>3</sub>
		(n - 1)	(n)				
Data Mask for DQ <sub>0</sub> to DQ <sub>7</sub>	MASK0	H	X	H	X	X	X
Data Mask for DQ <sub>8</sub> to DQ <sub>15</sub>	MASK1	H	X	X	H	X	X
Data Mask for DQ <sub>16</sub> to DQ <sub>23</sub>	MASK2	H	X	X	X	H	X
Data Mask for DQ <sub>24</sub> to DQ <sub>31</sub>	MASK3	H	X	X	X	X	H

**CKE TRUTH TABLE**

Current State	Function	Notes	Command	CKE		$\overline{\text{CS}}$	$\overline{\text{RAS}}$	$\overline{\text{CAS}}$	$\overline{\text{WE}}$	AP	BA <sub>0</sub> to BA <sub>2</sub>	A <sub>0</sub> to A <sub>10</sub>	DQ <sub>0</sub> to DQ <sub>31</sub>
				(n-1)	(n)								
Idle	Auto-refresh	*11	REF	H	H	L	L	L	H	X	X	X	—
Idle	Self-refresh Entry	*11 *12	SELF	H	L	L	L	L	H	X	X	X	Hi-Z
Self-refresh	Self-refresh Continue		—	L	L	X	X	X	X	X	X	X	Hi-Z
Self-refresh	Self-refresh Exit		SELFX	L	H	L	H	H	H	X	X	X	Hi-Z
				L	H	H	X	X	X	X	X	X	X
Idle	Power Down Entry	*13	PDEN	H	L	L	H	H	H	X	X	X	Hi-Z
				H	L	H	X	X	X	X	X	X	X
Power Down	Power Down Continue		—	L	L	X	X	X	X	X	X	X	Hi-Z
Power Down	Power Down Exit		PDEX	L	H	L	H	H	H	X	X	X	Hi-Z
				L	H	H	X	X	X	X	X	X	X

\*11: The REF and SELF commands should only be issued after all banks have been precharged (PRE or PALL command). In case of SELF command, it should also be issued after the last read data have been appeared on DQ. Refer to "■ STATE DIAGRAM".

\*12: CKE must bring to Low level together with REF command.

\*13: The PDEN command should only be issued after the last read data have been appeared on DQ and after the t<sub>DPL</sub> is satisfied from last write data input.

# MB81P643287-50/-60

OPERATION COMMAND TABLE (Applicable to single bank)(Note\*13)

Current State	$\overline{CS}$	$\overline{RAS}$	$\overline{CAS}$	$\overline{WE}$	Address	Command	Function	Notes
Idle	H	X	X	X	X	DESL	NOP	
	L	H	H	H	X	NOP	NOP	
	L	H	H	L	X	BST	NOP	*15
	L	H	L	H	BA, CA, AP	READ/READA	Illegal	*16
	L	H	L	L	BA, CA, AP	WRIT/WRITA	Illegal	*16
	L	L	H	H	BA, RA	ACTV	Bank Active after $t_{RCB}$	
	L	L	H	L	BA, AP	PRE	NOP	
	L	L	H	L	BA, AP	PALL	NOP	*15
	L	L	L	H	X	REF/SELF	Auto-refresh or Self-refresh	*17
	L	L	L	L	MODE	MRS	Mode Register Set (Idle after $t_{MRD}$ )	*17
Bank Active	H	X	X	X	X	DESL	NOP	
	L	H	H	H	X	NOP	NOP	
	L	H	H	L	X	BST	NOP	*15
	L	H	L	H	BA, CA, AP	READ/READA	Begin Read; Determine AP	
	L	H	L	L	BA, CA, AP	WRIT/WRITA	Begin Write; Determine AP	
	L	L	H	H	BA, RA	ACTV	Illegal	*16
	L	L	H	L	BA, AP	PRE	Precharge	
	L	L	H	L	BA, AP	PALL	Precharge	*15
	L	L	L	H	X	REF/SELF	Illegal	
	L	L	L	L	MODE	MRS	Illegal	

# MB81P643287-50/-60

**OPERATION COMMAND TABLE (Continued)**

Current State	$\overline{CS}$	$\overline{RAS}$	$\overline{CAS}$	$\overline{WE}$	Address	Command	Function	Notes
Read	H	X	X	X	X	DESL	NOP (Continue Burst to End → Bank Active)	
	L	H	H	H	X	NOP	NOP (Continue Burst to End → Bank Active)	
	L	H	H	L	X	BST	Terminate Burst → Bank Active	
	L	H	L	H	BA, CA, AP	READ/READA	Terminate Burst, New Read; Determine AP	
	L	H	L	L	BA, CA, AP	WRIT/WRITA	Illegal	
	L	L	H	H	BA, RA	ACTV	Illegal	*16
	L	L	H	L	BA, AP	PRE	Terminate Burst, Precharge	
	L	L	H	L	BA, AP	PALL	Terminate Burst, Precharge	*15
	L	L	L	H	X	REF/SELF	Illegal	
	L	L	L	L	MODE	MRS	Illegal	
Write	H	X	X	X	X	DESL	NOP (Continue Burst to End → Write Recovering)	
	L	H	H	H	X	NOP	NOP (Continue Burst to End → Write Recovering)	
	L	H	H	L	X	BST	Illegal	
	L	H	L	H	BA, CA, AP	READ/READA	Terminate Burst, Start Read; Determine AP	*20
	L	H	L	L	BA, CA, AP	WRIT/WRITA	Terminate Burst, New Write; Determine AP	
	L	L	H	H	BA, RA	ACTV	Illegal	*16
	L	L	H	L	BA, AP	PRE	Terminate Burst, Precharge	*18
	L	L	H	L	BA, AP	PALL	Terminate Burst, Precharge	*15, *18
	L	L	L	H	X	REF/SELF	Illegal	
	L	L	L	L	MODE	MRS	Illegal	

# MB81P643287-50/-60

OPERATION COMMAND TABLE (Continued)

Current State	$\overline{CS}$	$\overline{RAS}$	$\overline{CAS}$	$\overline{WE}$	Address	Command	Function	Notes
Read With Auto-Precharge	H	X	X	X	X	DESL	NOP (Continue Burst to End → Precharge)	
	L	H	H	H	X	NOP	NOP (Continue Burst to End → Precharge)	
	L	H	H	L	X	BST	Illegal	
	L	H	L	H	BA, CA, AP	READ/READA	Illegal	*16
	L	H	L	L	BA, CA, AP	WRIT/WRITA	Illegal	
	L	L	H	H	BA, RA	ACTV	Illegal	*16
	L	L	H	L	BA, AP	PRE	Illegal	*16
	L	L	H	L	BA, AP	PALL	Illegal	
	L	L	L	H	X	REF/SELF	Illegal	
Write with Auto-Precharge	L	L	L	L	MODE	MRS	Illegal	
	H	X	X	X	X	DESL	NOP (Continue Burst to End → Write Recovering with Precharge)	
	L	H	H	H	X	NOP	NOP (Continue Burst to End → Write Recovering with Precharge)	
	L	H	H	L	X	BST	Illegal	
	L	H	L	H	BA, CA, AP	READ/READA	Illegal	
	L	H	L	L	BA, CA, AP	WRIT/WRITA	Illegal	*16
	L	L	H	H	BA, RA	ACTV	Illegal	*16
	L	L	H	L	BA, AP	PRE	Illegal	*16
	L	L	H	L	BA, AP	PALL	Illegal	
L	L	L	H	X	REF/SELF	Illegal		
L	L	L	L	MODE	MRS	Illegal		

# MB81P643287-50/-60

**OPERATION COMMAND TABLE (Continued)**

Current State	$\overline{CS}$	$\overline{RAS}$	$\overline{CAS}$	$\overline{WE}$	Address	Command	Function	Notes
Precharging	H	X	X	X	X	DESL	NOP (Idle after I <sub>RP</sub> )	
	L	H	H	H	X	NOP	NOP (Idle after I <sub>RP</sub> )	
	L	H	H	L	X	BST	NOP (Idle after I <sub>RP</sub> )	*15
	L	H	L	H	BA, CA, AP	READ/READA	Illegal	*16
	L	H	L	L	BA, CA, AP	WRIT/WRITA	Illegal	*16
	L	L	H	H	BA, RA	ACTV	Illegal	*16
	L	L	H	L	BA, AP	PRE	NOP	*16
	L	L	H	L	BA, AP	PALL	NOP	*15
	L	L	L	H	X	REF/SELF	Illegal	
	L	L	L	L	MODE	MRS	Illegal	
Bank Activating	H	X	X	X	X	DESL	NOP (Bank Active after I <sub>RCD</sub> )	
	L	H	H	H	X	NOP	NOP (Bank Active after I <sub>RCD</sub> )	
	L	H	H	L	X	BST	NOP (Bank Active after I <sub>RCD</sub> )	*15
	L	H	L	H	BA, CA, AP	READ/READA	Illegal	*16
	L	H	L	L	BA, CA, AP	WRIT/WRITA	Illegal	*16
	L	L	H	H	BA, RA	ACTV	Illegal	*19
	L	L	H	L	BA, AP	PRE	Illegal	*16
	L	L	H	L	BA, AP	PALL	Illegal	
	L	L	L	H	X	REF/SELF	Illegal	
	L	L	L	L	MODE	MRS	Illegal	

# MB81P643287-50/-60

OPERATION COMMAND TABLE (Continued)

Current State	$\overline{CS}$	$\overline{RAS}$	$\overline{CAS}$	$\overline{WE}$	Address	Command	Function	Notes
Write Recovering	H	X	X	X	X	DESL	NOP (Bank Active after IWRD)	
	L	H	H	H	X	NOP	NOP (Bank Active after IWRD)	
	L	H	H	L	X	BST	NOP (Bank Active after IWRD)	*15
	L	H	L	H	BA, CA, AP	READ/READA	Illegal	*16
	L	H	L	L	BA, CA, AP	WRIT/WRITA	New Write; Determine AP	
	L	L	H	H	BA, RA	ACTV	Illegal	*16
	L	L	H	L	BA, AP	PRE	Illegal	*16
	L	L	H	L	BA, AP	PALL	Illegal	
	L	L	L	H	X	REF/SELF	Illegal	
	L	L	L	L	MODE	MRS	Illegal	
Write Recovering with Auto-precharge	H	X	X	X	X	DESL	NOP (Idle after I <sub>WAL</sub> )	
	L	H	H	H	X	NOP	NOP (Idle after I <sub>WAL</sub> )	
	L	H	H	L	X	BST	Illegal	
	L	H	L	H	BA, CA, AP	READ/READA	Illegal	*16
	L	H	L	L	BA, CA, AP	WRIT/WRITA	Illegal	*16
	L	L	H	H	BA, RA	ACTV	Illegal	*16
	L	L	H	L	BA, AP	PRE	Illegal	*16
	L	L	H	L	BA, AP	PALL	Illegal	
	L	L	L	H	X	REF/SELF	Illegal	
	L	L	L	L	MODE	MRS	Illegal	
Refreshing	H	X	X	X	X	DESL	NOP (Idle after I <sub>RFC</sub> )	
	L	H	H	X	X	NOP/BST	NOP (Idle after I <sub>RFC</sub> )	
	L	H	L	X	X	READ/READA/ WRIT/WRITA	Illegal	
	L	L	H	X	X	ACTV/ PRE/PALL	Illegal	
	L	L	L	X	X	REF/SELF/ MRS	Illegal	

# MB81P643287-50/-60

**OPERATION COMMAND TABLE (Continued)**

Current State	$\overline{CS}$	$\overline{RAS}$	$\overline{CAS}$	$\overline{WE}$	Address	Command	Function	Notes
Mode Register Setting	H	X	X	X	X	DESL	NOP (Idle after I <sub>MRD</sub> )	
	L	H	H	H	X	NOP	NOP (Idle after I <sub>MRD</sub> )	
	L	H	H	L	X	BST	Illegal	
	L	H	L	X	X	READ/READA/ WRIT/WRITA	Illegal	
	L	L	X	X	X	ACTV/PRE/ PALL/REF/ SELF/MRS	Illegal	

Abbreviations: RA = Row Address    BA = Bank Address  
CA = Column Address    AP = Auto Precharge

- Notes: \*14. All entries assume the CKE was High during the preceding clock cycle and the current clock cycle.  
 \*15. Entry may affect other banks.  
 \*16. Illegal to bank in specified state; entry may be legal in the bank specified by BA, depending on the state of that bank.  
 \*17. Illegal if any bank is not idle.  
 \*18. Must mask preceding data that don't satisfy IDPL.  
 \*19. Legal if other bank specified in BA is idle state and IRRD is satisfied for that bank.  
 \*20. Must mask preceding data that don't satisfy IWRD.

# MB81P643287-50/-60

COMMAND TRUTH TABLE FOR CKE

Current State	CKE (n-1)	CKE (n)	$\overline{CS}$	$\overline{RAS}$	$\overline{CAS}$	$\overline{WE}$	Address	Function	Notes
Self-refresh	H	X	X	X	X	X	X	Invalid	
	L	H	H	X	X	X	X	Exit Self-refresh (Self-refresh Recovery → Idle after $t_{PDEX} + t_{SCD}$ or $t_{XSNR}$ )	
	L	H	L	H	H	H	X	Exit Self-refresh (Self-refresh Recovery → Idle after $t_{PDEX} + t_{SCD}$ or $t_{XSNR}$ )	
	L	H	L	H	H	L	X	Illegal	
	L	H	L	H	L	X	X	Illegal	
	L	H	L	L	X	X	X	Illegal	
	L	L	X	X	X	X	X	NOP (Maintain Self-refresh)	
Self-refresh Recovery	L	X	X	X	X	X	X	Invalid	
	H	H	H	X	X	X	X	Idle after $t_{SCD}$ or $t_{XSNR}$	
	H	H	L	H	H	H	X	Idle after $t_{SCD}$ or $t_{XSNR}$	
	H	H	L	H	H	L	X	Illegal	
	H	H	L	H	L	X	X	Illegal	
	H	H	L	L	X	X	X	Illegal	
	H	L	X	X	X	X	X	Illegal	
Power Down	H	X	X	X	X	X	X	Invalid	
	L	H	H	X	X	X	X	Power Down Exit → Return to original state after $t_{PDEX}$	
	L	H	L	H	H	H	X	Power Down Exit → Return to original state after $t_{PDEX}$	
	L	H	L	H	H	L	X	Illegal	
	L	H	L	H	L	X	X	Illegal	
	L	H	L	L	X	X	X	Illegal	
	L	L	X	X	X	X	X	NOP (Maintain Power Down Mode)	

# MB81P643287-50/-60

COMMAND TRUTH TABLE FOR CKE (continued)

Current State	CKE (n-1)	CKE (n)	$\overline{CS}$	$\overline{RAS}$	$\overline{CAS}$	$\overline{WE}$	Address	Function	Notes
All Banks Idle	H	H	H	X	X	X	X	NOP	
	H	H	L	H	X	X	V	Refer to the Command Truth Table.	
	H	H	L	L	H	X	V	Refer to the Command Truth Table.	
	H	H	L	L	L	H	X	Auto-refresh	
	H	H	L	L	L	L	V	Mode Register Set	*21
	H	L	H	X	X	X	X	Power Down Entry	*22
	H	L	L	H	H	H	X	Power Down Entry	*22
	H	L	L	H	H	L	X	Illegal	
	H	L	L	H	L	X	X	Illegal	
	H	L	L	L	H	X	X	Illegal	
	H	L	L	L	L	H	X	Self-refresh Entry	*22
	H	L	L	L	L	L	X	Illegal	
	L	X	X	X	X	X	X	Invalid	
Bank Active	H	H	X	X	X	X	X	Refer to the Command Truth Table.	
	H	L	X	X	X	X	X	Illegal	
	L	H	X	X	X	X	X	Invalid	
	L	L	X	X	X	X	X	Invalid	

# MB81P643287-50/-60

COMMAND TRUTH TABLE FOR CKE (continued)

Current State	CKE (n-1)	CKE (n)	$\overline{CS}$	$\overline{RAS}$	$\overline{CAS}$	$\overline{WE}$	Address	Function	Notes
Bank Activating, Read, Write, Write Recovering, Precharging	H	H	X	X	X	X	X	Refer to the Command Truth Table.	
	H	L	X	X	X	X	X	Illegal	*23
	L	H	X	X	X	X	X	Invalid	
	L	L	X	X	X	X	X	Invalid	
Any State Other Than Listed Above	L	X	X	X	X	X	X	Invalid	
	H	H	X	X	X	X	X	Refer to the Command Truth Table.	
	H	L	X	X	X	X	X	Illegal	*23
Refresh	H	L	H	L	L	L	X	Illegal	
	H	L	L	H	H	H	X	Illegal	
	H	L	L	H	H	L	X	Illegal	
	H	L	L	H	L	X	X	Illegal	
	H	L	L	L	X	X	X	Illegal	
	L	L	X	X	X	X	X	Invalid	
	L	H	X	X	X	X	X	Invalid	
	H	H	X	X	X	X	X	Refer to the Command Truth Table.	

Notes: \*21. Refer to "■ MODE REGISTER TABLE".

\*22. PDEN and SELF command should only be issued after the last read data have been appeared on DQ.

\*23. The Clock Suspend mode is not supported on this device and it is illegal if CKE is brought to Low during the Burst Read or Write mode.

# MB81P643287-50/-60

## ■ STATE DIAGRAM

### MINIMUM CLOCK LATENCY OR DELAY TIME FOR SINGLE BANK OPERATION

Second command (same bank) First command	MRS	ACTV	READ	READA	WRIT	WRITA	BST	<sup>*1</sup> PRE	PALL	REF	SELF
MRS	lMRD	lMRD					lMRD	lMRD	lMRD	lMRD	lMRD
ACTV			lRCD	lRCD <sup>*4</sup>	lRCD	lRCD <sup>*4</sup>	1	lRAS	lRAS		
READ			1	1 <sup>*4</sup>	lRWD <sup>*3</sup>	lRWD <sup>*3,4</sup>	1	1 <sup>*4</sup>	1 <sup>*4</sup>		
READA	<sup>*5,6</sup> BL/2 + lRP	BL/2 + lRP						<sup>*4</sup> BL/2 + lRP	<sup>*4</sup> BL/2 + lRP	<sup>*6</sup> BL/2 + lRP	<sup>*5,6</sup> BL/2 + lRP
WRIT			lWRD <sup>*7</sup>	lWRD <sup>*4,7</sup>	1	1 <sup>*4</sup>		<sup>*4,7</sup> lDPL	<sup>*4,7</sup> lDPL		
WRITA	<sup>*6</sup> lWAL	lWAL						<sup>*4</sup> lWAL	<sup>*4</sup> lWAL	<sup>*6</sup> lWAL	<sup>*6</sup> lWAL
BST			1	1	lBSNC <sup>*3</sup>	lBSNC <sup>*3</sup>	1	1 <sup>*4</sup>	1 <sup>*4</sup>		
PRE	<sup>*5,6</sup> lRP	lRP					1	1	1 <sup>*4</sup>	<sup>*6</sup> lRP	<sup>*5,6</sup> lRP
PALL	<sup>*5</sup> lRPA	lRPA					1	1	1	lRPA	<sup>*5</sup> lRPA
REF	lRFC	lRFC					lRFC	lRFC	lRFC	lRFC	lRFC
SELF	lXSNR	lXSNR					lXSNR	lXSNR	lXSNR	lXSNR	lXSNR

Notes: \*1.  $BL/2 = t_{CK} \times BL / 2$ . (Example: In case of  $BL = 4$ ,  $BL/2$  means 2 clocks.)

\*2. Assume PALL command does not affect any operation on the other bank(s).

\*3. Assume no I/O conflict.

\*4. lRAS must be satisfied.

\*5. Assume all outputs are in High-Z state.

\*6. Assume all other banks are in idle state.

\*7. lDPL and lWRD are specified from last data input and assumed preceding pair of write data are masked by  $DM_0$  to  $DM_3$  input.

 Illegal Command

# MB81P643287-50/-60

MINIMUM CLOCK LATENCY OR DELAY TIME FOR MULTIPLE BANK OPERATION

Second command (other bank) <sup>*10</sup>	MRS	ACTV	<sup>*8</sup> READ	<sup>*8</sup> READA	<sup>*8</sup> WRIT	<sup>*8</sup> WRITA	<sup>*9</sup> BST	<sup>*2,9</sup> PRE	PALL	REF	SELF
First command											
MRS	lMRD	lMRD					lMRD	lMRD	lMRD	lMRD	lMRD
ACTV		<sup>*6</sup> lRRD	<sup>*11</sup> 1	<sup>*11</sup> 1	<sup>*11</sup> 1	<sup>*11</sup> 1	<sup>*11</sup> 1	1	lRAS		
READ		<sup>*6</sup> 1	1	1	<sup>*3</sup> lRWD	<sup>*3</sup> lRWD	1	1	<sup>*4</sup> 1		
READA	<sup>*5,6</sup> BL/2+ lRP	<sup>*6</sup> 1	<sup>*4</sup> 1	<sup>*4</sup> 1	<sup>*3,4</sup> lRWD	<sup>*3,4</sup> lRWD		1	BL/2+ lRP	<sup>*6</sup> BL/2+ lRP	<sup>*5,6</sup> BL/2+ lRP
WRIT		<sup>*6</sup> 1	<sup>*7</sup> lWRD	<sup>*7</sup> lWRD	1	1		1	<sup>*4,7</sup> lDPL		
WRITA	<sup>*6</sup> lWAL	<sup>*6</sup> 1	<sup>*4</sup> BL/2 + lWRD	<sup>*4</sup> BL/2 + lWRD	<sup>*4</sup> 1	<sup>*4</sup> 1		1	lWAL	<sup>*6</sup> lWAL	<sup>*6</sup> lWAL
BST		<sup>*6</sup> 1	<sup>*11</sup> 1	<sup>*11</sup> 1	<sup>*3,11</sup> lBSNC	<sup>*3,11</sup> lBSNC	1	1	<sup>*4</sup> 1		
PRE	<sup>*5,6</sup> lRP	<sup>*6</sup> 1	<sup>*11</sup> 1	<sup>*11</sup> 1	<sup>*3,11</sup> 1	<sup>*3,11</sup> 1	<sup>*11</sup> 1	1	<sup>*4</sup> 1	<sup>*6</sup> lRP	<sup>*5,6</sup> lRP
PALL	<sup>*5</sup> lRPA	lRPA					1	1	1	lRPA	<sup>*5</sup> lRPA
REF	lRFC	lRFC					lRFC	lRFC	lRFC	lRFC	lRFC
SELF	lXSNR	lXSNR					lXSNR	lXSNR	lXSNR	lXSNR	lXSNR

# MB81P643287-50/-60

- Notes:
- \*1.  $BL/2 = t_{CK} \times BL / 2$ . (Example: In case of  $BL = 4$ ,  $BL/2$  means 2 clocks.)
  - \*2. Assume PALL command does not affect any operation on the other bank(s).
  - \*3. Assume no I/O conflict.
  - \*4.  $I_{RAS}$  must be satisfied.
  - \*5. Assume all outputs are in High-Z state.
  - \*6. Assume the other bank(s) is in idle state.
  - \*7.  $I_{DPL}$  and  $I_{WRD}$  are specified from last data input and assumed preceding pair of write data are masked by  $DM_0$  to  $DM_3$  input.
  - \*8. Assume the other bank(s) is in active state and  $I_{RCD}$  is satisfied.
  - \*9. Assume the other bank(s) is in active state and  $I_{RAS}$  is satisfied.
  - \*10. Second command have to follow the minimum clock latency or delay time of single bank operation in other bank (second command is asserted.)
  - \*11. Assume other banks are not in READA/WRITE state.



Illegal Command.

# MB81P643287-50/-60

Fig. 2 - STATE DIAGRAM (Simplified for Single Bank Operation)

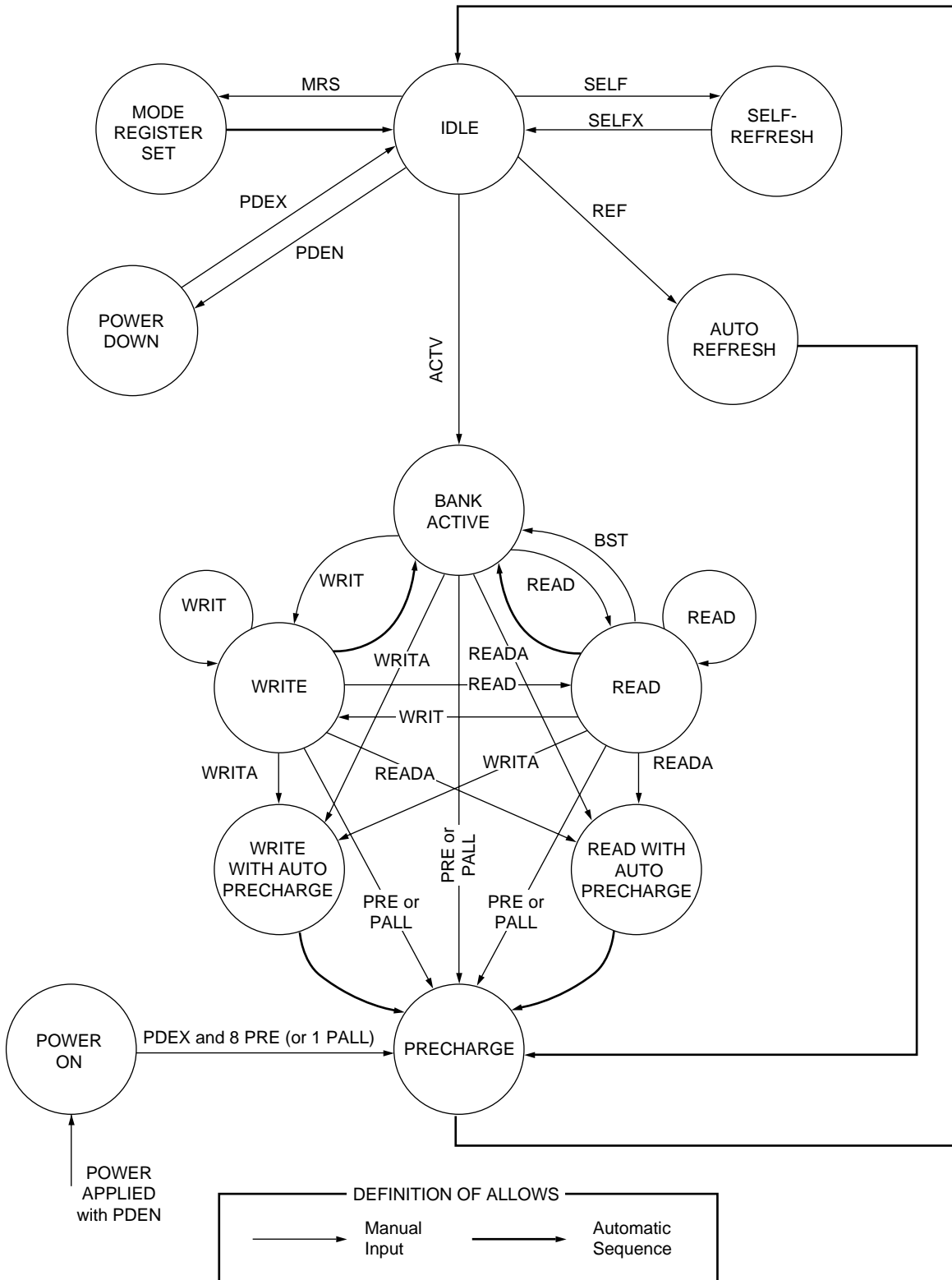

## ■ FUNCTIONAL DESCRIPTION

### DDR, Double Data Rate Function

The regular SDRAM read and write cycle have only used the rising edge of external clock input. When clock signal goes to High from Low at the read mode, the read out data will be available at every rising clock edge after the specified latency up to burst length. The MB81P643287 DDR FCRAM features a twice of data transfer rate within a same clock period by transferring data at every rising and falling clock edge. Refer to Figure 3.

### FCRAM™

The MB81P643287 utilizes FCRAM core technology. The FCRAM is an acronym of Fast Cycle Random Access Memory and provides very fast random cycle time, low latency and low power consumption than regular DRAMs.

### CLOCK INPUT (CLK, $\overline{\text{CLK}}$ )

The MB81P643287 adopts differential clock scheme. CLK is a master clock and its rising edge is used to latch all command and address inputs.  $\overline{\text{CLK}}$  is a complementary clock input.

The MB81P643287 implements Delay Locked Loop (DLL) circuit. This internal DLL tracks the signal cross point between CLK and  $\overline{\text{CLK}}$  and generate some clock cycle delay for the output buffer control at Read mode.

The internal DLL circuit requires some Lock-on time for the stable delay time generation. In order to stabilize the delay, a constant stable clock input for  $t_{PCD}$  period is required during the Power-up initialization and a constant stable clock input for  $t_{SCD}$  period is also required after Self-refresh exit as specified  $t_{SCD}$  prior to the any command.

### POWER DOWN (CKE)

CKE is a synchronous input signal and enables power down mode.

When all banks are in idle state, CKE controls Power Down (PD) and Self-refresh mode. The PD and Self-refresh is entered when CKE is brought to Low and exited when it returns to High.

During the Power Down and Self-refresh mode, both CLK and  $\overline{\text{CLK}}$  are disabled after specified time.

CKE does not have a Clock Suspend function unlike CKE pin of regular SDRAMs, and it is illegal to bring CKE into Low if any read or write operation is being performed. For the detail, refer to Timing Diagrams.

It is recommended to maintain CKE to be Low until  $V_{DD}$  gets in the specified operating range in order to assure the power-up initialization.

### CHIP SELECT ( $\overline{\text{CS}}$ )

$\overline{\text{CS}}$  enables all commands inputs,  $\overline{\text{RAS}}$ ,  $\overline{\text{CAS}}$ , and  $\overline{\text{WE}}$ , and address input. When  $\overline{\text{CS}}$  is High, all command signals are negated but internal operation such as burst cycle will not be suspended.

### COMMAND INPUTS ( $\overline{\text{RAS}}$ , $\overline{\text{CAS}}$ and $\overline{\text{WE}}$ )

As well as regular SDRAMs, each combination of  $\overline{\text{RAS}}$ ,  $\overline{\text{CAS}}$  and  $\overline{\text{WE}}$  input in conjunction with  $\overline{\text{CS}}$  input at a rising edge of the CLK determines SDRAM operation. Refer to “■FUNCTION TRUTH TABLE”.

# MB81P643287-50/-60

## **BANK ADDRESS (BA<sub>0</sub> to BA<sub>2</sub>)**

The MB81P643287 has eight internal banks and each bank is organized as 256K words by 32-bit. Bank selection by BA occurs at Bank Active command (ACTV) followed by read (READ or READA), write (WRIT or WRITA), and Precharge(PRE) command.

## **ADDRESS INPUTS (A<sub>0</sub> to A<sub>10</sub>)**

Address input selects an arbitrary location of a total of 2,097,152 words of each memory cell matrix within each bank. A total of twenty address input signals are required to decode such a matrix. DDR SDRAM adopts an address multiplexer in order to reduce the pin count of the address line. At a Bank Active command (ACTV), eleven Row addresses are initially latched as well as three Bank addresses and the remainder of seven Column addresses are then latched by a Column address strobe command of either a read command (READ or READA) or write command (WRIT or WRITA).

## **DATA STROBE (DQS<sub>0</sub> to DQS<sub>3</sub>)**

DQS<sub>0</sub> to DQS<sub>3</sub> are bi-directional signal and represent byte 0 to byte 3, respectively. During Read operation, DQS<sub>0</sub> to DQS<sub>3</sub> provides the read data strobe signal that is intended to use input data strobe signal at the receiver circuit of the controller(s). It turns Low before first data is coming out and toggle High to Low or Low to High till end of burst read. Refer to Figure 3 for the timing example.

The CAS Latency is specified to the first Low to High transition of these DQS<sub>0</sub> to DQS<sub>3</sub> output.

During the write operation, DQS<sub>0</sub> to DQS<sub>3</sub> are used to latch write data and Data Mask signals. As well as the behavior of read data strobe, the first rising edge of DQS<sub>0</sub> to DQS<sub>3</sub> input latches first input data and following falling edge of DQS<sub>0</sub> to DQS<sub>3</sub> signal latches second input data. This sequence shall be continued till end of burst count. Therefore, DQS<sub>0</sub> to DQS<sub>3</sub> must be provided from controller that drives write data.

Note that DQS<sub>0</sub> to DQS<sub>3</sub> input signal should not be tristated from High at the end of write mode.

## **DATA INPUTS AND OUTPUTS (DQ<sub>0</sub> to DQ<sub>31</sub>)**

Input data is latched by DQS<sub>0</sub> to DQS<sub>3</sub> input signal and written into memory at the clock following the write command input. Output data is obtained together with DQS<sub>0</sub> to DQS<sub>3</sub> output signals at programmed read CAS latency.

The polarity of the output data is identical to that of the input. Data is valid after DQS<sub>0</sub> to DQS<sub>3</sub> output signal transitions ( $t_{0SQ}$ ) as specified in Data Valid Time ( $t_{DV}$ ).

## **WRITE DATA MASK (DM<sub>0</sub> to DM<sub>3</sub>)**

DM<sub>0</sub> to DM<sub>3</sub> are active High enable inputs and represent byte 0 to byte 3 respectively. DM<sub>0</sub> to DM<sub>3</sub> have a data input mask function, and are also sampled by DQS<sub>0</sub> to DQS<sub>3</sub> input signal together with input data.

During write cycle, DM<sub>0</sub> to DM<sub>3</sub> provide byte mask function. When DM<sub>x</sub> = High is latched by a DQS<sub>0</sub> to DQS<sub>3</sub> signal edge, data input at the same edge of DQS<sub>0</sub> to DQS<sub>3</sub> is masked.

During read cycle, all DM<sub>0</sub> to DM<sub>3</sub> are inactive and do not have any effect on read operation.

Refer to DM<sub>0</sub> to DM<sub>3</sub> TRUTH TABLE.

# MB81P643287-50/-60

## BURST MODE OPERATION AND BURST TYPE

The burst mode provides faster memory access and MB81P643287 read and write operations are burst oriented. The burst mode is implemented by keeping the same Row address and by automatic strobing Column address in every single clock edge till programmed burst length(BL). Access time of burst mode is specified as  $t_{ACC}$ . The internal column address counter operation is determined by a mode register which defines burst type(BT) and burst count length(BL) of 2, 4 or 8 bits of boundary. In order to terminate or to move from the current burst mode to the next stage while the remaining burst count is more than 2, the following combinations will be required.

Current Stage	Next Stage	Method (Assert the following command)	
Burst Read	Burst Read	Read Command	
Burst Read	Burst Write	1st Step	<b>Burst Stop Command (BST)</b>
		2nd Step	Write Command after $I_{BSNC}$
Burst Write	Burst Write	Write Command	
Burst Write	Burst Read	1st Step	<b>Data Mask Input</b>
		2nd Step	Read Command after $I_{WRD}$ from last data input
Burst Read	Precharge	Precharge Command	
Burst Write	Precharge	1st Step	<b>Data Mask Input</b>
		2nd Step	Precharge Command after $I_{DPL}$ from last data input

The burst type is sequential only. The sequential mode is an incremental decoding scheme within a boundary address to be determined by count length, it assigns +1 to the previous (or initial) address until reaching the end of boundary address and then wraps round to the least significant address(= 0). If the first access of column address is even (0), the next address will be odd (1), or vice-versa.

Burst Length	Starting Column Address			Sequential Mode
	A <sub>2</sub>	A <sub>1</sub>	A <sub>0</sub>	
2	X	X	0	0 - 1
	X	X	1	1 - 0
4	X	0	0	0 - 1 - 2 - 3
	X	0	1	1 - 2 - 3 - 0
	X	1	0	2 - 3 - 0 - 1
	X	1	1	3 - 0 - 1 - 2
8	0	0	0	0 - 1 - 2 - 3 - 4 - 5 - 6 - 7
	0	0	1	1 - 2 - 3 - 4 - 5 - 6 - 7 - 0
	0	1	0	2 - 3 - 4 - 5 - 6 - 7 - 0 - 1
	0	1	1	3 - 4 - 5 - 6 - 7 - 0 - 1 - 2
	1	0	0	4 - 5 - 6 - 7 - 0 - 1 - 2 - 3
	1	0	1	5 - 6 - 7 - 0 - 1 - 2 - 3 - 4
	1	1	0	6 - 7 - 0 - 1 - 2 - 3 - 4 - 5
	1	1	1	7 - 0 - 1 - 2 - 3 - 4 - 5 - 6

# MB81P643287-50/-60

## BURST STOP COMMAND (BST)

The Burst Stop command (BST) terminates the burst read operation except for a case that Auto-precharge option is asserted. When the BST command is issued during the burst read operation, the all output buffers, DQs and DQS<sub>0</sub> to DQS<sub>3</sub>, will turn to High-Z state after some latencies that to be matched with programmed CAS latency and internal bank state remains active state.

In a case of terminating the burst write operation, the BST command should not be issued at any time during burst write operation. Refer to previous page for the write interrupt and termination rule.

## PRECHARGE AND PRECHARGE OPTION (PRE, PALL)

The DDR SDRAM memory core is the same as conventional DRAMs', requiring precharge and refresh operations. Precharge rewrites the bit line and to reset the internal Row address line and is executed by the precharge operation (PRE or PALL). With the precharge operation, DDR SDRAM will automatically be in standby state after specified precharge time ( $t_{RP}$ ,  $t_{RPA}$ ).

The precharged bank is selected by combination of AP and bank address (BA) when precharge command is issued. If AP = High, all banks are precharged regardless of BA (PALL command). If AP = Low, a bank to be selected by BA is precharged (PRE command).

The auto-precharge enters precharge mode at the end of burst mode of read or write without Precharge command issue. This auto-precharge is entered by AP = High when a Read (READ) or Write (WRIT) command is issued. Applying BST is illegal if the Auto-precharge option is used.

Refer to "FUNCTION TRUTH TABLE".

## AUTO-REFRESH (REF)

Auto-refresh uses the internal refresh address counter. The MB81P643287 Auto-refresh command (REF) automatically generates Bank Active and Precharge command internally. All banks of SDRAM should be precharged prior to the Auto-refresh command. The Auto-refresh command should also be issued within every 8  $\mu$ s period.

## SELF-REFRESH ENTRY (SELF)

Self-refresh function provides automatic refresh by an internal timer as well as Auto-refresh and will continue the refresh operation until cancelled by SELFX.

The Self-refresh mode is entered by applying an Auto-refresh command in conjunction with CKE = Low (SELF). Once MB81P643287 enters the self-refresh mode, all inputs except for CKE can be either logic high or low level state and outputs will be in a High-Z state. During Self-refresh mode, CKE = Low should be maintained. SELF command should only be issued after last read data has been appeared on DQ.

Note: When the burst refresh method is used, a total of 4096 auto-refresh commands within 4 ms must be asserted prior to the self-refresh mode entry.

## SELF-REFRESH EXIT (SELFX)

To exit Self-refresh mode, CKE must bring to High for at least 2 clock cycles together with NOP condition.

Refer to Timing Diagram for the detail procedure. It is recommended to issue at least one Auto-refresh command just after the  $t_{RFC}$  period to avoid the violation of refresh period.

WARNING: A stable clock for  $t_{SCD}$  period with a constant duty cycle must be supplied prior to applying any read command to insure the DLL is locked against the latest device conditions.

Note: When the burst refresh method is used, a total of 4096 auto-refresh commands within 4 ms must be asserted both before the self-refresh entry and after the self-refresh exit.

# MB81P643287-50/-60

## MODE REGISTER SET (MRS)

The mode register of SDRAM provides a variety of different operations. The register consists of four operation fields; Burst Length, Burst Type, CAS Latency, and Test Mode Entry (This Test Mode Entry must not be used). Refer to MODE REGISTER TABLE.

The mode register can be programmed by the Mode Register Set command (MRS). Each field is set by the address line. Once a mode register is programmed, the contents of the register will be held until re-programmed by another MRS command (or part loses power). MRS command should only be issued on condition that all banks are in idle state and all DQS are in High-Z. The condition of the mode register is undefined after the power-up stage. It is required to set each field at power-up initialization.

Refer to POWER-UP INITIALIZATION below.

Note: The Extended Mode Register Set command (EMRS) and its DLL Enable function of EMRS field is only used at power-on sequence.

## POWER-UP INITIALIZATION

The MB81P643287 internal condition at and after power-up will be undefined. It is required to follow the following Power On Sequence to execute read or write operation.

1. Apply  $V_{DD}$  voltage to all  $V_{DD}$  pins before or at the same time as  $V_{DDQ}$  pins and attempt to maintain all input signals to be Low state (or at least CKE to be Low state).
2. Apply  $V_{DD}$  voltage to all  $V_{DDQ}$  pins before or at the same time as  $V_{REF}$  and  $V_{TT}$ .
3. Apply  $V_{REF}$  and  $V_{TT}$ . ( $V_{TT}$  is applied to the system).
4. Start clock after all power supplies reached in a specified operating range and maintain stable condition for a minimum of 200  $\mu$ s.
5. After the minimum of 200  $\mu$ s stable power and clock, apply NOP condition and take CKE to be High state.
6. Issue Precharge All Banks (PALL) command or Precharge Single Bank (PRE) command to every banks.
7. Issue EMRS to enable DLL, DE = Low.
8. Issue Mode Register Set command (MRS) to reset DLL, DR = High. An additional clock input for  $I_{PCD}$ \*1 period is required to lock the DLL.
9. Apply minimum of two Auto-refresh command (REF).\*2
10. Program the mode register by Mode Register Set command (MRS) with DR = Low.\*2

\*1: The  $I_{PCD}$  depends on operating clock period. The  $I_{PCD}$  is counted from "DLL Reset" at step-8 to any command input at step-10.

\*2: The Mode Register Set command (MRS) can be issued before two Auto-refresh cycle.

## POWER-DOWN

The MB81P643287 uses multiple power supply voltage. It is required to follow the reversed sequence of above Power On Sequence.

1. Take all input signals to be  $V_{SS}$  or High-Z.
2. Deapply  $V_{DDQ}$ .
3. Deapply  $V_{DD}$  at the same time as  $V_{DDQ}$ .

# MB81P643287-50/-60

Fig. 3 - SDRAM READ TIMING EXAMPLE (@ CL=2 & BL=2)

<SDRAM>

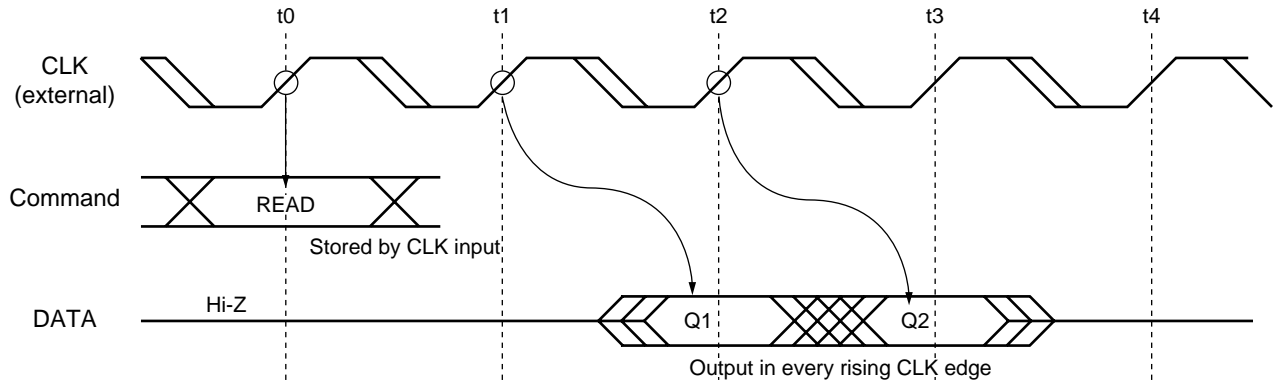

< DDR SDRAM >

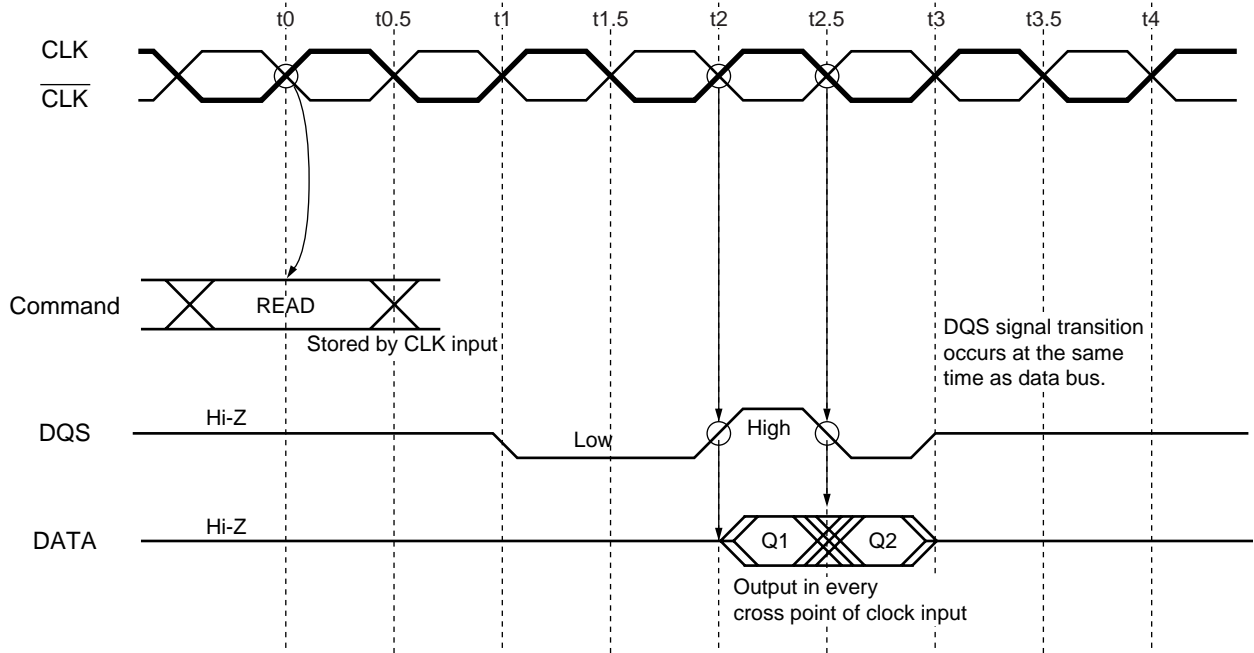

## MODE REGISTER TABLE

### MODE REGISTER SET

ADDRESS	BA <sub>2</sub>	BA <sub>1</sub>	BA <sub>0</sub>	A <sub>10</sub>	A <sub>9</sub>	A <sub>8</sub>	A <sub>7</sub>	A <sub>6</sub> to A <sub>4</sub>	A <sub>3</sub>	A <sub>2</sub> to A <sub>0</sub>
REGISTER	0 <sup>*1</sup>	0 <sup>*1</sup>	0 <sup>*1</sup>	0	0	DR	TE	CL	BT	BL

A <sub>6</sub>	A <sub>5</sub>	A <sub>4</sub>	CAS Latency (CL)
0	0	X	Reserved
0	1	0	2
0	1	1	3
1	0	0	Reserved
1	0	1	Reserved
1	1	0	Reserved
1	1	1	Reserved

A <sub>2</sub>	A <sub>1</sub>	A <sub>0</sub>	Burst Length (BL)
0	0	0	Reserved
0	0	1	2
0	1	0	4
0	1	1	8
1	X	X	Reserved

A <sub>7</sub>	Test Mode Entry (TE)
0	Normal Operation
1	Test Mode (Used for Supplier Test Mode)

A <sub>3</sub>	Burst Type (BT)
0	Sequential (Wrap round, Binary up)
1	Reserved

A <sub>8</sub>	DLL RESET (DR)
0	Normal Operation
1	RESET DLL

### EXTENDED MODE REGISTER SET (Note \*4)

ADDRESS	BA <sub>2</sub>	BA <sub>1</sub>	BA <sub>0</sub>	A <sub>10</sub>	A <sub>9</sub>	A <sub>8</sub>	A <sub>7</sub>	A <sub>6</sub>	A <sub>5</sub>	A <sub>4</sub>	A <sub>3</sub>	A <sub>2</sub>	A <sub>1</sub>	A <sub>0</sub>
EXTENDED MODE REGISTER	0 <sup>*2</sup>	0 <sup>*2</sup>	1 <sup>*2</sup>	RESERVED <sup>*3</sup>										DE

A <sub>0</sub>	DLL Enable (DE)
0	DLL Enable
1	DLL Disable

\*1: A combination of BA<sub>2</sub> = BA<sub>1</sub> = BA<sub>0</sub> = 0 (Low) selects standard Mode Register.

\*2: A combination of BA<sub>1</sub> = BA<sub>2</sub> = 0 and BA<sub>0</sub> = 1 (High) selects Extended Mode Register.

\*3: These RESERVED field in EMRS must be set as 0.

# MB81P643287-50/-60

## ■ ABSOLUTE MAXIMUM RATINGS (See WARNING)

Parameter	Symbol	Value	Unit
Voltage of $V_{DD}$ Supply Relative to $V_{SS}$	$V_{DD}, V_{DDQ}$	-0.5 to +3.6	V
Voltage at Any Pin Relative to $V_{SS}$	$V_{IN}, V_{OUT}$	-0.5 to +3.6	V
Short Circuit Output Current	$I_{OUT}$	$\pm 50$	mA
Power Dissipation	$P_D$	2.0	W
Storage Temperature	$T_{STG}$	-55 to +125	$^{\circ}C$

WARNING: Semiconductor devices can be permanently damaged by application of stress (voltage, current, temperature, etc.) in excess of absolute maximum ratings. Do not exceed these ratings.

## ■ RECOMMENDED OPERATING CONDITIONS

(Referenced to  $V_{SS}$ )

Parameter	Notes	Symbol	Min.	Typ.	Max.	Unit
Supply Voltage		$V_{DD}$	2.3	2.5	2.7	V
		$V_{DDQ}$	$V_{DD}$	$V_{DD}$	$V_{DD}$	V
		$V_{SS}, V_{SSQ}$	0	0	0	V
Input Reference Voltage	*1	$V_{REF}$	$V_{DDQ} \times 0.49$	$V_{DDQ} \times 0.5$	$V_{DDQ} \times 0.51$	V
Termination Voltage	*2	$V_{TT}$	$V_{REF} - 0.04$	$V_{REF}$	$V_{REF} + 0.04$	V
Single Ended SSTL DC Level Input High Voltage	*3	$V_{IH(DC)}$	$V_{REF} + 0.25$	—	$V_{DDQ} + 0.1$	V
Single Ended SSTL DC Level Input Low Voltage	*3	$V_{IL(DC)}$	-0.1	—	$V_{REF} - 0.25$	V
Single Ended SSTL AC Level Input High Voltage	*3, *5	$V_{IH(AC)}$	$V_{REF} + 0.35$	—	—	V
Single Ended SSTL AC Level Input Low Voltage	*3, *5	$V_{IL(AC)}$	—	—	$V_{REF} - 0.35$	V
Differential DC Level Input Voltage Range	*3	$V_{IN(DC)}$	-0.1	—	$V_{DDQ} + 0.1$	V
Differential DC Level Differential Input Voltage	*3	$V_{SWING(DC)}$	0.5	—	$V_{DDQ} + 0.2$	V
Differential AC Level Differential Input Voltage	*3	$V_{SWING(AC)}$	0.7	—	—	V
Differential AC Level Input Crosspoint Voltage	*3	$V_{X(AC)}$	$V_{DDQ}/2 - 0.2$	$V_{DDQ}/2$	$V_{DDQ}/2 + 0.2$	V
Differential Input Signal Offset Voltage	*4	$V_{ISO(AC)}$	$V_{DDQ}/2 - 0.2$	$V_{DDQ}/2$	$V_{DDQ}/2 + 0.2$	V
Termination Resistor (SSTL I/Os)	*2	$R_T$	—	50	—	$\Omega$
Ambient Temperature		$T_A$	0	—	70	$^{\circ}C$

### Note 5.

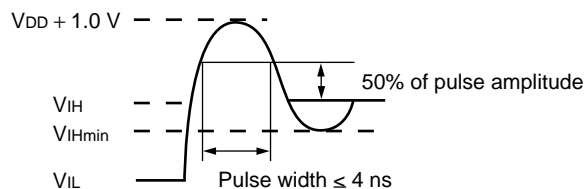

### Note 6.

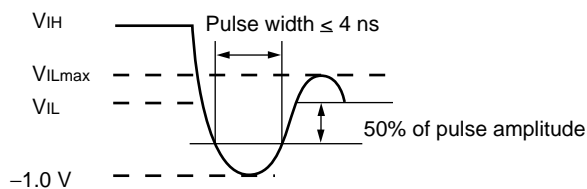

# MB81P643287-50/-60

- Notes:
- \*1.  $V_{REF}$  is expected to track variations in the DC level of  $V_{DDQ}$  of the transmitting device. Peak-to-Peak noise level on  $V_{REF}$  may not exceed  $\pm 2\%$  of the supplied DC value.
  - \*2.  $V_{TT}$  is used for SSTL\_2 bus and is not applied to the device.  $V_{TT}$  is expected to be set equal to  $V_{REF}$  and must track variations in the DC level of  $V_{REF}$ .
  - \*3. Applicable when signal(s) is terminated to the  $V_{TT}$  of SSTL\_2 bus.
  - \*4.  $V_{ISO}$  means  $\{V_{IN(CLK)} + V_{IN(\overline{CLK})}\} / 2$ . Refer to Differential Input Signal Definition.
  - \*5. Overshoot limit:  $V_{IH} (Max.) = V_{DD} + 1.0V$  for pulse width  $\leq 4$  ns acceptable, pulse width measured at 50% of pulse amplitude.
  - \*6. Undershoot limit:  $V_{IL} (Min.) = V_{SS} - 1.0V$  for pulse width  $\leq 4$  ns acceptable, pulse width measured at 50% of pulse amplitude.

**WARNING:** The recommended operating conditions are required in order to ensure the normal operation of the semiconductor device. All of the device's electrical characteristics are warranted when the device is operated within these ranges.

Always use semiconductor devices within their recommended operating condition ranges. Operation outside these ranges may adversely affect reliability and could result in device failure.

No warranty is made with respect to uses, operating conditions, or combinations not represented on the data sheet. Users considering application outside the listed conditions are advised to contact their FUJITSU representatives beforehand.

## Differential Input Signal Definition

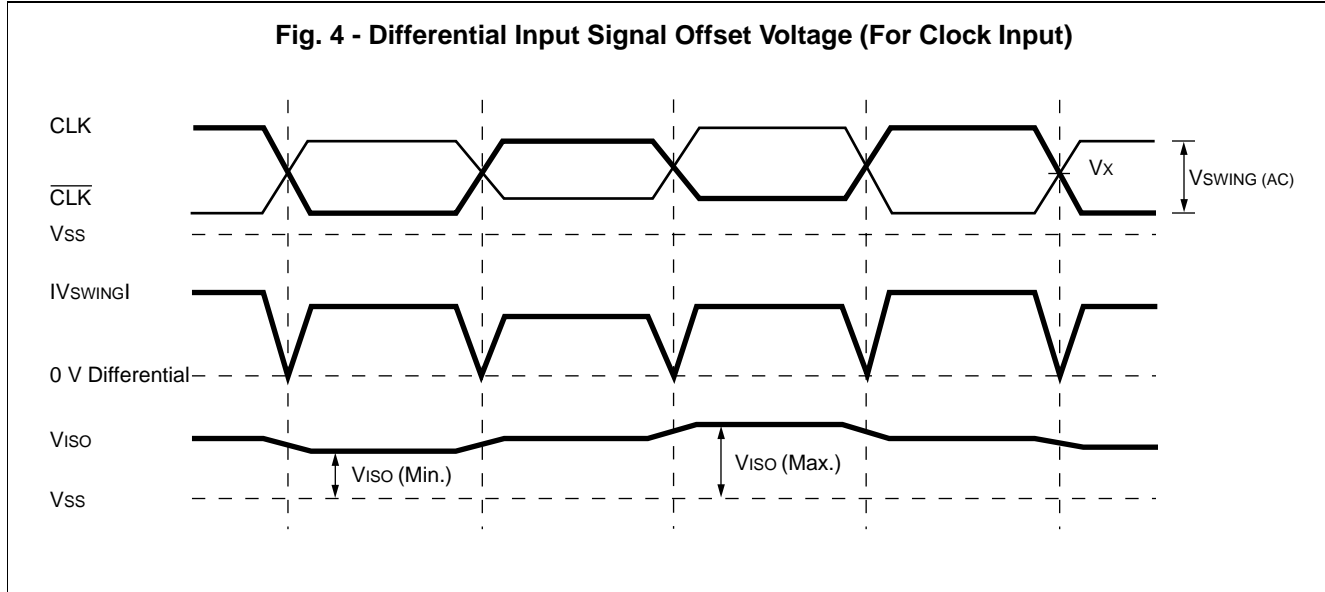

## ■ CAPACITANCE

( $T_A = 25^\circ C$ ,  $f = 1$  MHz)

Parameter	Symbol	Min.	Typ.	Max.	Unit
Input Capacitance, Address & Control	$C_{IN1}$	2.5	—	3.5	pF
Input Capacitance, CLK & $\overline{CLK}$	$C_{IN2}$	2.5	—	3.5	pF
Input Capacitance, $DM_0$ to $DM_3$	$C_{IN3}$	4.0	—	5.5	pF
I/O Capacitance	$C_{I/O}$	4.0	—	5.5	pF

# MB81P643287-50/-60

## ■ DC CHARACTERISTICS

(At recommended operating conditions unless otherwise noted.) Note \*1,\*2,\*3

Parameter		Symbol	Condition	Value		Unit
				Min.	Max.	
Output Minimum Source DC Current		$I_{OH(DC)}$	$V_{DDQ} = 2.3V,$ $V_{OH} = V_{DDQ} - 0.43V$	-15.2	—	mA
Output Minimum Sink DC Current		$I_{OL(DC)}$	$V_{DDQ} = 2.3V,$ $V_{OL} = +0.35V$	15.2	—	mA
Input Leakage Current (any input)		$I_{LI}$	$0V \leq V_{IN} \leq V_{DD};$ All other pins not under test = 0V	-10	10	$\mu A$
Output Leakage Current		$I_{LO}$	$0V \leq V_{IN} \leq V_{DD};$ Data out disabled	-10	10	$\mu A$
V <sub>REF</sub> Current		$I_{REF}$		-10	10	$\mu A$
Operating Current (Average Power Supply Current)	MB81P643287-50	$I_{DD1S}$	Burst Length = 2 $t_{CK} = \text{Min.},$ One bank active, Address change up to 3 times during $I_{RC}$ (Min.) $0V \leq V_{IN} \leq V_{IL}$ (Max.), $V_{IH}$ (Min.) $\leq V_{IN} \leq V_{DD}$	—	460	mA
	MB81P643287-60				405	
Standby Current	MB81P643287-50	$I_{DD2N}$	CKE = $V_{IH}, t_{CK} = \text{Min.}$ All banks idle, NOP commands only, Input signals (except to CMD) are changed one time during 20 ns $0V \leq V_{IN} \leq V_{IL}$ (Max.), $V_{IH}$ (Min.) $\leq V_{IN} \leq V_{DD}$	—	85	mA
	MB81P643287-60				75	
Power Down Current		$I_{DD2P}$	CKE = $V_{IL}, t_{CK} = \text{Min.}$ All banks idle, $0V \leq V_{IN} \leq V_{DD}$	—	35	mA
Active Standby Current (Power Supply Current)	MB81P643287-50	$I_{DD3N}$	CKE = $V_{IH}, t_{CK} = \text{Min.}$ All banks Active, NOP commands only, Input signals (except to CMD) are changed one time during 20 ns $0V \leq V_{IN} \leq V_{IL}$ (Max.), $V_{IH}$ (Min.) $\leq V_{IN} \leq V_{DD}$	—	260	mA
	MB81P643287-60				225	

(Continued)

# MB81P643287-50/-60

(Continued)

Parameter		Symbol	Condition	Value		Unit
				Min.	Max.	
Burst Read Current (Average Power Supply Current)	MB81P643287-50	I <sub>DD4R</sub>	Burst Length = 4, CAS Latency = 3, All bank active, Gapless data, t <sub>CK</sub> = Min., 0 V ≤ V <sub>IN</sub> ≤ V <sub>IL</sub> (Max.), V <sub>IH</sub> (Min.) ≤ V <sub>IN</sub> ≤ V <sub>DD</sub>	—	535	mA
	MB81P643287-60			—	460	
Burst Write Current (Average Power Supply Current)	MB81P643287-50	I <sub>DD4W</sub>	Burst Length = 4, CAS Latency = 3, All bank active, Gapless data, t <sub>CK</sub> = Min., 0 V ≤ V <sub>IN</sub> ≤ V <sub>IL</sub> (Max.), V <sub>IH</sub> (Min.) ≤ V <sub>IN</sub> ≤ V <sub>DD</sub>	—	595	mA
	MB81P643287-60			—	505	
Auto-refresh Current (Average Power Supply Current)	MB81P643287-50	I <sub>DD5</sub>	Auto-refresh; t <sub>CK</sub> = Min., 0 V ≤ V <sub>IN</sub> ≤ V <sub>IL</sub> (Max.), V <sub>IH</sub> (Min.) ≤ V <sub>IN</sub> ≤ V <sub>DD</sub>	—	320	mA
	MB81P643287-60			—	270	
Self-refresh Current (Average Power Supply Current)		I <sub>DD6</sub>	Self-refresh; CKE = V <sub>IL</sub> , 0 V ≤ V <sub>IN</sub> ≤ V <sub>DD</sub>	—	5	mA

Notes: \*1. All voltages referenced to V<sub>SS</sub>.

\*2. DC characteristics are measured after following the POWER-UP INITIALIZATION procedure.

\*3. I<sub>DD</sub> depends on the output termination or load conditions, clock cycle rate, and number of address and command change within certain period. The specified values are obtained with the output open.

# MB81P643287-50/-60

## ■ AC CHARACTERISTICS

(Recommended operating conditions unless otherwise noted.) Note \*1,\*2,\*3

### AC PARAMETERS (CAS LATENCY DEPENDENT)

Parameter	Symbol		MB81P643287-50		MB81P643287-60		Unit
			Min.	Max.	Min.	Max.	
Clock Period	t <sub>CK</sub>	CL = 3	5.0	9.0	6.0	10.5	ns
		CL = 2	7.5	10.5	9.0	10.5	

Parameter	Notes	Symbol	MB81P643287-50		MB81P643287-60		Unit
			Min.	Max.	Min.	Max.	
Input Setup Time (Except for DQS, DM and DQs)	*4	t <sub>IS</sub>	1.0	—	1.2	—	ns
Input Hold Time (Except for DQS, DM and DQs)	*4	t <sub>IH</sub>	1.0	—	1.2	—	ns
DM and Data Input Setup Time	*5	t <sub>DS</sub>	0.6	—	0.7	—	ns
DM and Data Input Hold Time	*5	t <sub>DH</sub>	0.6	—	0.7	—	ns
DQS First Input Setup Time (Input Preamble Setup Time)	*6	t <sub>DSPRES</sub>	0	—	0	—	ns
Last Data Output to CKE High Level Hold Time		t <sub>QCKEH</sub>	0	—	0	—	ns
Input Transition Time	*7	t <sub>TR</sub>	0.1	0.8	0.1	0.9	ns
Precharge Power Down Exit and Self-refresh Exit Time	*4	t <sub>PDEX</sub>	3.0	—	3.6	—	ns
Time between Refresh	*8	t <sub>REF</sub>	—	32	—	32	ms
Time between Auto-refresh Command	*8	t <sub>AREF</sub>	—	8.0	—	8.0	μs
Pause Time after Power-on		t <sub>PAUSE</sub>	200	—	200	—	μs

# MB81P643287-50/-60

## AC PARAMETERS (FREQUENCY DEPENDANT) Note \*9

Parameter	Notes	Symbol	Min.	Max.	Unit
Clock High Time	*4	$t_{CH}$	$0.45 \times t_{CK}$	—	ns
Clock Low Time	*4	$t_{CL}$	$0.45 \times t_{CK}$	—	ns
DQS Low to High Input Transition Setup Time from CLK	*4, *10	$t_{DQSS}$	$0.75 \times t_{CK}$	$1.25 \times t_{CK}$	ns
DQS Low Input Pulse Width		$t_{DSL}$	$0.4 \times t_{CK}$	—	ns
DQS High Input Pulse Width		$t_{DSH}$	$0.4 \times t_{CK}$	—	ns
DQS First Low Input Hold Time (Input Preamble Hold Time)	*4	$t_{DSPREH}$	$0.25 \times t_{CK}$	—	ns
DQS First Low Input Pulse Width (Input Preamble Pulse Width)		$t_{DSPRE}$	$0.4 \times t_{CK}$	—	ns
DQS Last Low Input Hold Time (Input Postamble Hold Time)		$t_{DSPST}$	$0.4 \times t_{CK}$	—	ns
DQS Access Time from Clock	*4	$t_{QSCK}$	$-0.1 \times t_{CK} - 0.2$	$0.1 \times t_{CK} + 0.2$	ns
DQS Output Valid Time		$t_{QSV}$	$0.3 \times t_{CK}$	—	ns
DQS Output in Low-Z (Output Preamble Setup Time)	*4, *11	$t_{QSLZ}$	$-0.1 \times t_{CK} - 0.2$	—	ns
DQS First Low Output Hold Time (Output Preamble Hold Time)	*4	$t_{QSPRE}$	$0.9 \times t_{CK} - 0.2$	$1.1 \times t_{CK} + 0.2$	ns
DQS Last Low Output Hold Time (Output Postamble Hold Time)	*4, *12	$t_{QSPST}$	$0.4 \times t_{CK} - 0.2$	$0.6 \times t_{CK} + 0.2$	ns
DQS Last Low Output in High-Z from CLK or $\overline{CLK}$	*12	$t_{QSHZ}$	—	$0.1 \times t_{CK} + 0.2$	ns
DQ Access Time from CLK & $\overline{CLK}$	*4	$t_{ACC}$	$-0.1 \times t_{CK} - 0.2$	$0.1 \times t_{CK} + 0.2$	ns
DQ Access Time from DQS	*5	$t_{ASQ}$	$-0.1 \times t_{CK}$	$0.1 \times t_{CK}$	ns
DQ Output Data Valid Time from DQS		$t_{DV}$	$0.3 \times t_{CK}$	—	ns
DQ Output in Low-Z	*4, *11	$t_{LZ}$	$-0.1 \times t_{CK} - 0.2$	—	ns
DQ Output in High-Z	*4, *12	$t_{HZ}$	$-0.1 \times t_{CK} - 0.2$	$0.1 \times t_{CK} + 0.2$	ns
DQ & DM Input Pulse Width		$t_{DIPW}$	$0.4 \times t_{CK}$	—	ns
DQS Falling Edge to Clock Hold Time		$t_{DSCH}$	$0.2 \times t_{CK}$ (1.5 ns Min.)	—	ns
DQS Falling Edge to Clock Setup Time		$t_{DSCS}$	$0.2 \times t_{CK}$ (1.5 ns Min.)	—	ns

# MB81P643287-50/-60

EXAMPLE OF FREQUENCY DEPENDANT AC PARAMETERS (@ Minimum  $t_{CK}$ )

Parameter	Symbol	$t_{CK} = 5ns$		$t_{CK} = 6ns$		$t_{CK} = 7.5ns$		$t_{CK} = 9ns$		$t_{CK} = 10.5ns$		Unit
		Min.	Max.	Min.	Max.	Min.	Max.	Min.	Max.	Min.	Max.	
Clock High Time	$t_{CH}$	2.3	—	2.7	—	3.4	—	4.1	—	4.8	—	ns
Clock Low Time	$t_{CL}$	2.3	—	2.7	—	3.4	—	4.1	—	4.8	—	ns
DQS Low to High Input Transition Setup Time from CLK	$t_{DQSS}$	3.8	6.3	4.5	7.5	5.7	9.4	6.8	11.3	7.9	13.2	ns
DQS Low Input Pulse Width	$t_{DSL}$	2.0	—	2.4	—	3.0	—	3.6	—	4.2	—	ns
DQS High Input Pulse Width	$t_{DSH}$	2.0	—	2.4	—	3.0	—	3.6	—	4.2	—	ns
DQS First Low Input Hold Time (Input Preamble Hold Time)	$t_{DSPREH}$	1.3	—	1.5	—	1.9	—	2.3	—	2.7	—	ns
DQS First Low Input Pulse Width (Input Preamble Pulse Width)	$t_{DSPRE}$	2.0	—	2.4	—	3.0	—	3.6	—	4.2	—	ns
DQS Last Low Input Hold Time (Postamble Hold Time)	$t_{DSPST}$	2.0	—	2.4	—	3.0	—	3.6	—	4.2	—	ns
DQS Access Time from Clock	$t_{QCK}$	-0.7	0.7	-0.8	0.8	-1.0	1.0	-1.1	1.1	-1.3	1.3	ns
DQS Output Valid Time	$t_{QSV}$	1.5	—	1.8	—	2.3	—	2.7	—	3.2	—	ns
DQS Output in Low-Z (Output Preamble)	$t_{QSLZ}$	-0.7	—	-0.8	—	-1.0	—	-1.1	—	-1.3	—	ns
DQS First Low Output Hold Time (Output Preamble)	$t_{QSPRE}$	4.3	5.7	5.2	6.8	6.6	8.5	7.9	10.1	9.3	11.8	ns
DQS Last Low Output Hold Time (Output Postamble)	$t_{QSPST}$	1.8	3.2	2.2	3.8	2.8	4.7	3.4	5.6	4.0	6.5	ns
DQS Last Low Output in High-Z from CLK or $\overline{CLK}$	$t_{QSHZ}$	—	0.7	—	0.8	—	1.0	—	1.1	—	1.3	ns
DQ Output Access Time from CLK & $\overline{CLK}$	$t_{ACC}$	-0.7	0.7	-0.8	0.8	-1.0	1.0	-1.1	1.1	-1.3	1.3	ns
DQ Output Access Time from DQS	$t_{QSQ}$	-0.5	0.5	-0.6	0.6	-0.8	0.8	-0.9	0.9	-1.1	1.1	ns
DQ Output Data Valid Time from DQS	$t_{DV}$	1.5	—	1.8	—	2.3	—	2.7	—	3.2	—	ns
DQ Output in Low-Z	$t_{LZ}$	-0.7	—	-0.8	—	-1.0	—	-1.1	—	-1.3	—	ns
DQ Output in High-Z	$t_{HZ}$	-0.7	0.7	-0.8	0.8	-1.0	1.0	-1.1	1.1	-1.3	1.3	ns
DQ & DM Input Pulse Width	$t_{DIPW}$	2.0	—	2.4	—	3.0	—	3.6	—	4.2	—	ns
DQS Falling Edge to Clock Hold Time	$t_{DSCH}$	1.5	—	1.5	—	1.5	—	1.8	—	2.1	—	ns
DQS Falling Edge to Clock Setup Time	$t_{DSCS}$	1.5	—	1.5	—	1.5	—	1.8	—	2.1	—	ns

# MB81P643287-50/-60

## LATENCY

(The latency values on these parameters are fixed regardless of clock period.)

Parameter	Notes	Symbol	MB81P643287-50		MB81P643287-60		Unit
			Min.	Max.	Min.	Max.	
$\overline{\text{RAS}}$ Cycle Time *13	CL = 3	I <sub>RC</sub>	6	—	6	—	t <sub>CK</sub>
	CL = 2		5	—	5	—	t <sub>CK</sub>
$\overline{\text{RAS}}$ Active Time	CL = 3	I <sub>RAS</sub>	4	11000	4	11000	t <sub>CK</sub>
	CL = 2		3	7333	3	7333	t <sub>CK</sub>
$\overline{\text{RAS}}$ Precharge Time		I <sub>RP</sub>	2	—	2	—	t <sub>CK</sub>
$\overline{\text{RAS}}$ to $\overline{\text{CAS}}$ Delay Time	CL = 3	I <sub>RCD</sub>	3	—	3	—	t <sub>CK</sub>
	CL = 2		2	—	2	—	t <sub>CK</sub>
$\overline{\text{RAS}}$ to $\overline{\text{RAS}}$ Bank Active Delay Time		I <sub>RRD</sub>	1	—	1	—	t <sub>CK</sub>
Precharge All Bank to Active	CL = 3	I <sub>RPA</sub>	4	—	4	—	t <sub>CK</sub>
	CL = 2		3	—	3	—	t <sub>CK</sub>
Read Command to Write Command Delay	CL = 3	I <sub>RWD</sub>	BL/2+3	—	BL/2+3	—	t <sub>CK</sub>
	CL = 2		BL/2+2	—	BL/2+2	—	t <sub>CK</sub>
Last Input Data to Read Command Delay *14		I <sub>WRD</sub>	2.5	—	2.5	—	t <sub>CK</sub>
Last Input Data to Precharge Command Lead Time *14		I <sub>DPL</sub>	2.5	—	2.5	—	t <sub>CK</sub>
Write with Auto Precharge Command to Active command Delay *14		I <sub>WAL</sub>	BL/2+3+I <sub>RP</sub>	—	BL/2+3+I <sub>RP</sub>	—	t <sub>CK</sub>
Mode Register Access to Next Command Input Delay		I <sub>MRD</sub>	2	—	2	—	t <sub>CK</sub>
$\overline{\text{CAS}}$ to $\overline{\text{CAS}}$ Delay		I <sub>CCD</sub>	1	—	1	—	t <sub>CK</sub>
$\overline{\text{CAS}}$ Bank Delay		I <sub>CBD</sub>	1	—	1	—	t <sub>CK</sub>
Precharge Power Down Exit to Next Command Input Delay		I <sub>PDEXP</sub>	2	—	2	—	t <sub>CK</sub>
Minimum Stable Clock Input After Self-refresh Exit Before READ Command Input *15		I <sub>SCD</sub>	400	—	400	—	t <sub>CK</sub>
Minimum Stable Clock Input After Self-refresh Exit Before non-READ Command Input		I <sub>XSNR</sub>	12	—	12	—	t <sub>CK</sub>
Minimum Stable Clock Input for DLL Lock-on in Power-up Initialization sequence. *16	t <sub>CK</sub> ≤ 7.5ns	I <sub>PCD</sub>	400	—	400	—	t <sub>CK</sub>
	t <sub>CK</sub> ≤ 10.5ns		630	—	630	—	t <sub>CK</sub>
Auto-refresh Cycle Time		I <sub>RFC</sub>	12	—	12	—	t <sub>CK</sub>

# MB81P643287-50/-60

## LATENCY - FIXED VALUES

(The latency values on these parameters are fixed regardless of clock period.)

Parameter	Notes	Symbol	MB81P643287-50	MB81P643287-60	Unit
BST Command to Output in High-Z	CL = 3	I <sub>BSH</sub>	3	3	t <sub>CK</sub>
	CL = 2		2	2	t <sub>CK</sub>
BST Command to New Command Input *17	CL = 3	I <sub>BSNC</sub>	3	3	t <sub>CK</sub>
	CL = 2		2	2	t <sub>CK</sub>
DM to Input Data Delay		I <sub>DQD</sub>	0	0	t <sub>CK</sub>
Precharge to Output in High-Z	CL = 3	I <sub>ROH</sub>	3	3	t <sub>CK</sub>
	CL = 2		2	2	t <sub>CK</sub>
CKE Low to Command/Address Input Inactive		I <sub>CKE</sub>	1	1	t <sub>CK</sub>

# MB81P643287-50/-60

- Notes:
- \*1. AC characteristics are measured after following the POWER-UP INITIALIZATION procedure and stable clock input with constant clock period and with 50% duty cycle.
  - \*2. Access Times assume input slew rate of 1ns/volt between  $V_{REF}+0.35V$  to  $V_{REF}-0.35V$ , where  $V_{REF}$  is  $V_{DDQ}/2$ , with SSTL\_2 output load conditions. Refer to AC TEST LOAD CIRCUIT.
  - \*3.  $V_{REF} = 1.25V$  is a typical reference level for measuring timing of input signals. Transition times are measured between  $V_{IH}(\text{Min.})$  and  $V_{IL}(\text{Max.})$  unless otherwise noted. Refer to AC TEST CONDITIONS.
  - \*4. This parameter is measured from the cross point of CLK and  $\overline{CLK}$  input.
  - \*5. This parameter is measured from signal transition point of  $DQS_0$  to  $DQS_3$  input crossing  $V_{REF}$  level.
  - \*6. The specific requirement is that DQS be valid (HIGH or LOW) on or before this CLK edge. The case shown (DQS going from High-Z to logic LOW) applies when no writes were previously in progress on the bus. If a previous write was in progress, DQS could be HIGH at this time, depending on  $t_{DSS}$ .
  - \*7.  $t_T$  is defined as the transition time between  $V_{IH(AC)}(\text{Min.})$  and  $V_{IL(AC)}(\text{Max.})$ .
  - \*8. Total of 4096 REF command must be issued within  $t_{REF}(\text{Max.})$ .  $t_{REF}$  is a reference value for distributed refresh and specifies the time between one REF command to next REF command except for a condition where CKE = Low during Self-refresh mode.
  - \*9. This parameter is scalable by actual clock period ( $t_{CK}$ ) and affected by an abrupt change of duty cycle, jitters on clock input,  $T_A$  and level of  $V_{DD}$  and  $V_{DDQ}$ . The internal DLL circuit can adjust delay time against the change of following condition :
    - $T_A \leq 0.1 \text{ } ^\circ\text{C} / 20 \text{ ns,}$
    - $V_{DD} \leq 1 \text{ mV} / 10 \text{ ns,}$
    - $V_{DDQ} \leq 1 \text{ mV} / 10 \text{ ns,}$if change rate is bigger than these values, frequency dependent AC parameters affected by DLL jitters.
  - \*10. More than 2 signal edge of  $DQS_0$  to  $DQS_3$  should not be input within 1 clock ( $t_{CK}$ ) cycle.
  - \*11. Low-Z (Low Impedance State) is specified and measured at  $V_{TT} \pm 200\text{mV}$ .
  - \*12.  $t_{QSPST}$ ,  $t_{QSHZ}$  and  $t_{HZ}$  are specified where output buffer is no longer driven.
  - \*13. Actual clock count of  $I_{RC}$  will be sum of clock count of  $I_{RAS}$  and  $I_{RP}$ .
  - \*14. Assume  $t_{DQSS} = 1 \times t_{CK}$ . If actual  $t_{DQSS}$  is within specified minimum and maximum range, those parameters can be assumed  $t_{DQSS} = 1 \times t_{CK}$ .
  - \*15. Applicable also if device operating conditions such as supply voltages, case temperature, and/or clock frequency ( $t_{CK}$  difference must be 0.2 ns or less) is changed during any operation.
  - \*16. Clock period must satisfy specified  $t_{CK}$  and it must be stable.
  - \*17. Assume BST is effective to read operation (issued prior to the end of burst read).

# MB81P643287-50/-60

Fig. 5 - AC TEST LOAD CIRCUIT (SSTL\_2, Class II)

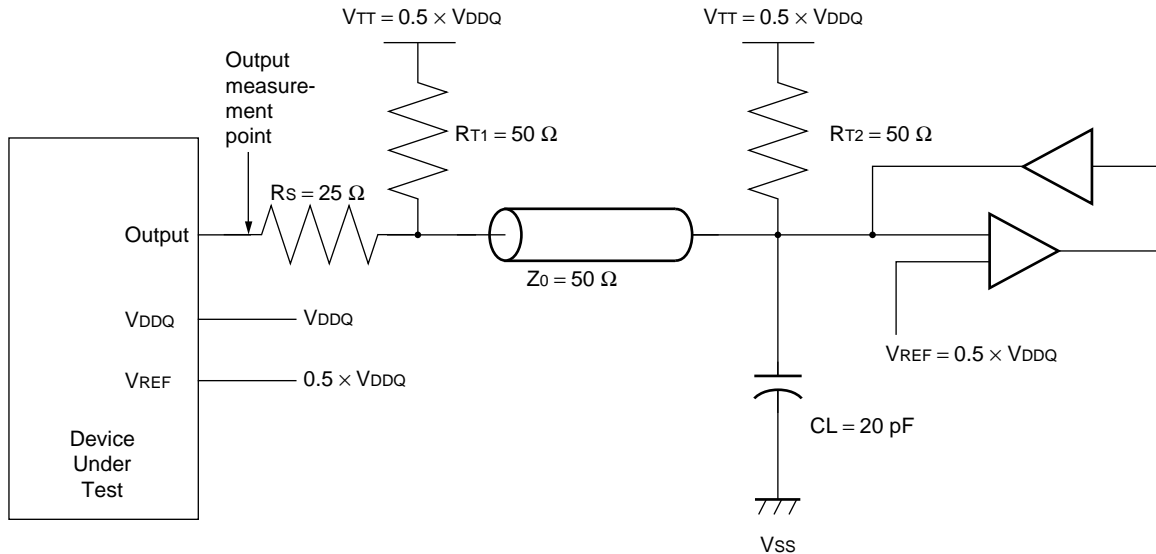

Note: AC characteristics are measured in this condition. This load circuit is not applicable for DC Test.

## AC TEST CONDITIONS

Parameters	Symbol	Value	Unit
Single-end Input			
Input High Level	$V_{IH}$	$V_{REF} + 0.35$	V
Input Low Level	$V_{IL}$	$V_{REF} - 0.35$	V
Input Reference Level	$V_{REF}$	$V_{DDQ} / 2$	V
Input Slew Rate	SLEW	1.0	V/ns
Differential Input (CLK and $\overline{CLK}$ )			
Input Reference Level	$V_r$	$V_{X(AC)}^*$	V
Input Level	$V_{SWING}$	0.7	V
Input Slew Rate	SLEW	1.0	V/ns

\* :  $V_x$  means the actual cross point between CLK and  $\overline{CLK}$  input.



# MB81P643287-50/-60

**Fig. 9 - AC TIMING of Read Mode (Clock to DQS Output Delay Time)**

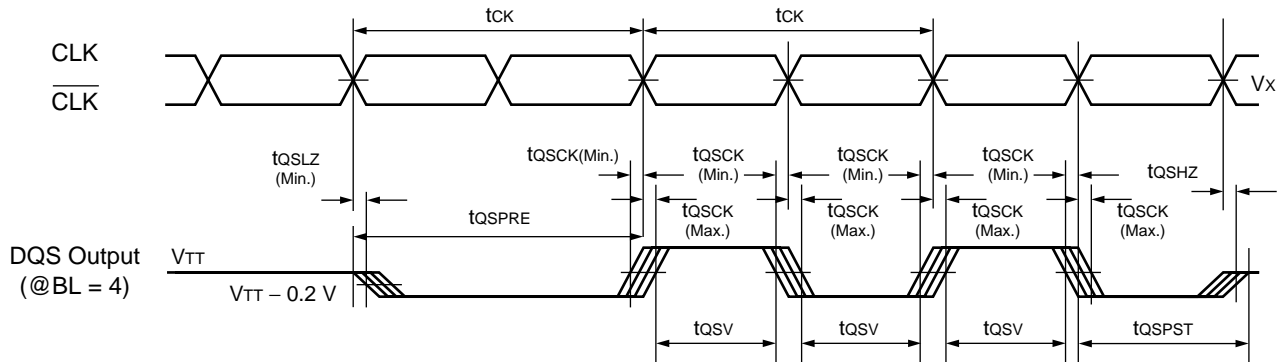

Note: DQS Access time ( $t_{QSCk}$ ) is measured from the cross point of clock ( $V_x$ ) and  $V_{REF}$ .  
The end of  $t_{QSPST}$  and  $t_{QSHZ}$  specification is defined at where output buffer is no longer driven.

**Fig. 10 - AC TIMING of Read Mode (Clock to Data Output Delay Time)**

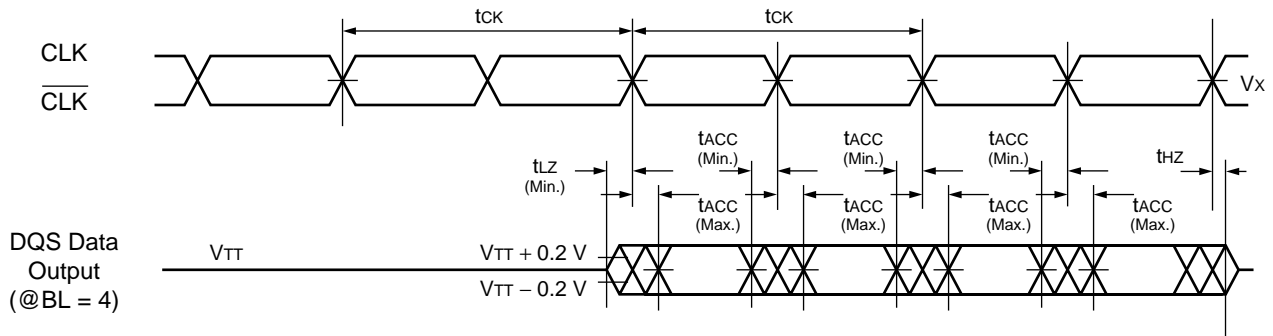

Note: Access time ( $t_{ACC}$ ) is measured from the cross point of clock ( $V_x$ ) and  $V_{REF}$ .  
The end of  $t_{HZ}$  specification is defined at where output buffer is no longer driven.

**Fig. 11 - AC TIMING of Read Mode (DQS Output to Data Output Delay Time)**

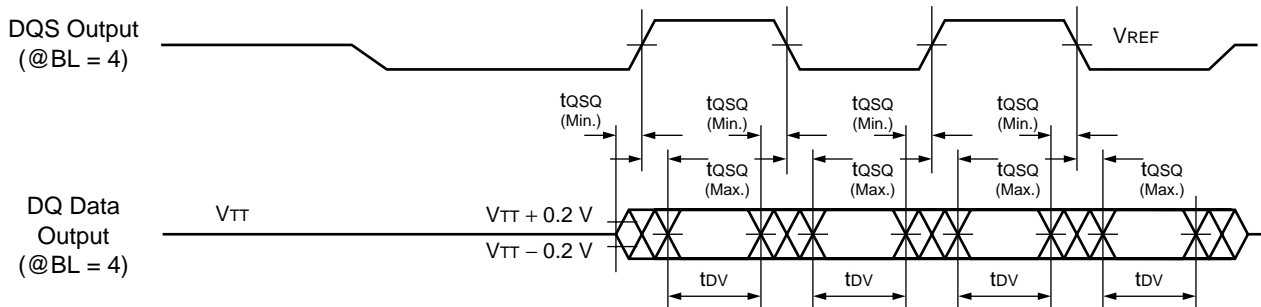

Note: DQS Output Edge to Data Output Edge Skew Time ( $t_{QSQ}$ ) is measured from  $V_{TT}$  to  $V_{TT}$ .

**Fig. 12 - AC TIMING, PULSE WIDTH**

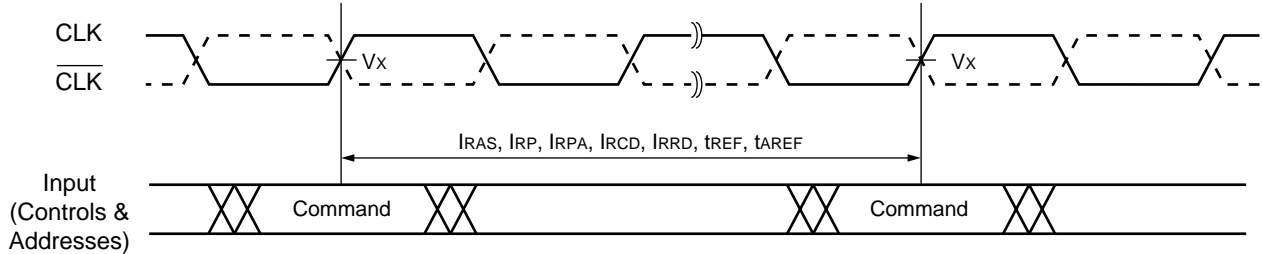

Note: All parameters listed above are measured from the cross point at rising edge of the CLK and falling edge of  $\overline{\text{CLK}}$  of one command input to next command input.

**Fig. 13 - AC TIMING of Precharge Power Down Mode**

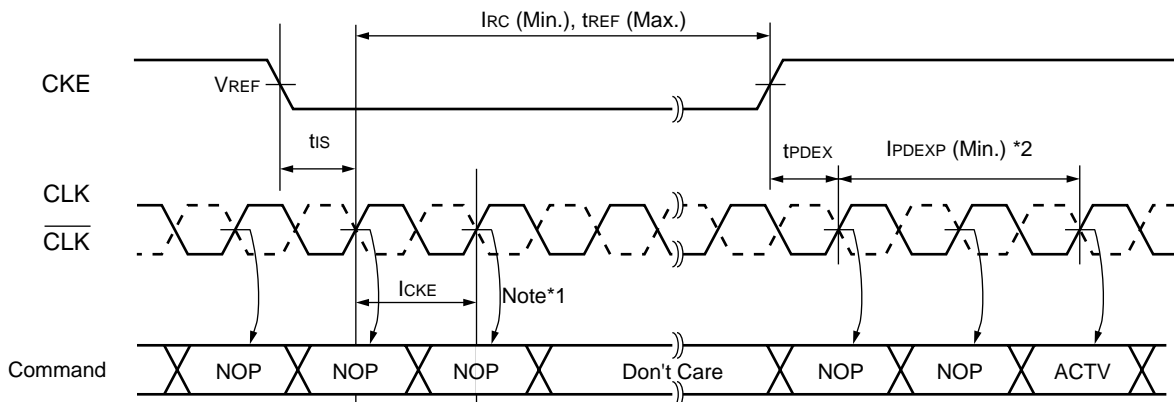

Notes: \*1. Minimum 2 clock cycles is required for complete power down on clock buffer.  
\*2. If either any supply voltage or clock input condition is changed from the previous operating condition (other than PDEN and REF),  $I_{\text{SCD}}$  must be satisfied prior to any command input.

**Fig. 14 - AC TIMING of Self-refresh Mode**

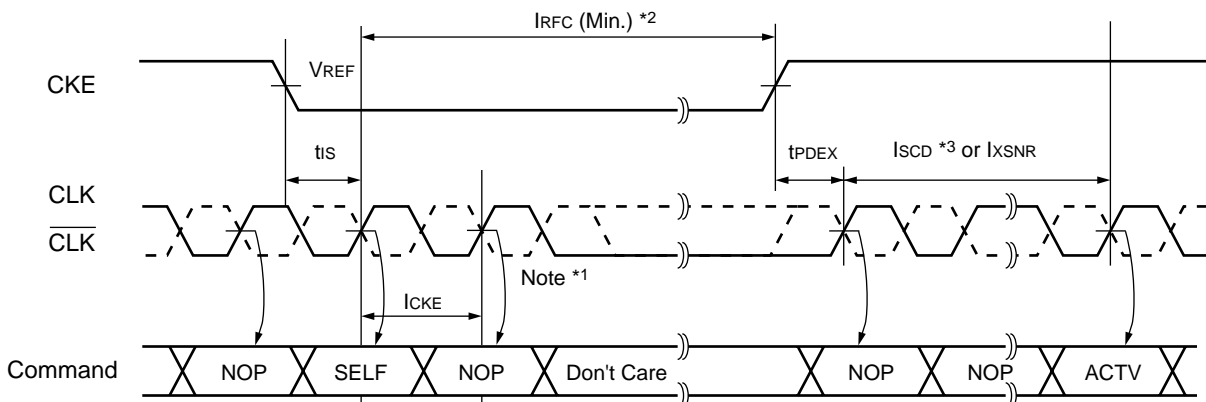

Notes: \*1. Minimum 2 clock cycles is required for complete power down on clock buffer.  
\*2. CKE must maintain High level and clock must be provided during the  $I_{\text{SCD}}$  period.  $I_{\text{SCD}}$  must be satisfied before read command input.  
\*3.  $I_{\text{SCD}}$  must be satisfied before read command input.

# MB81P643287-50/-60

## ■ TIMING DIAGRAMS

**TIMING DIAGRAM - 1: COLUMN ADDRESS TO COLUMN ADDRESS INPUT DELAY**

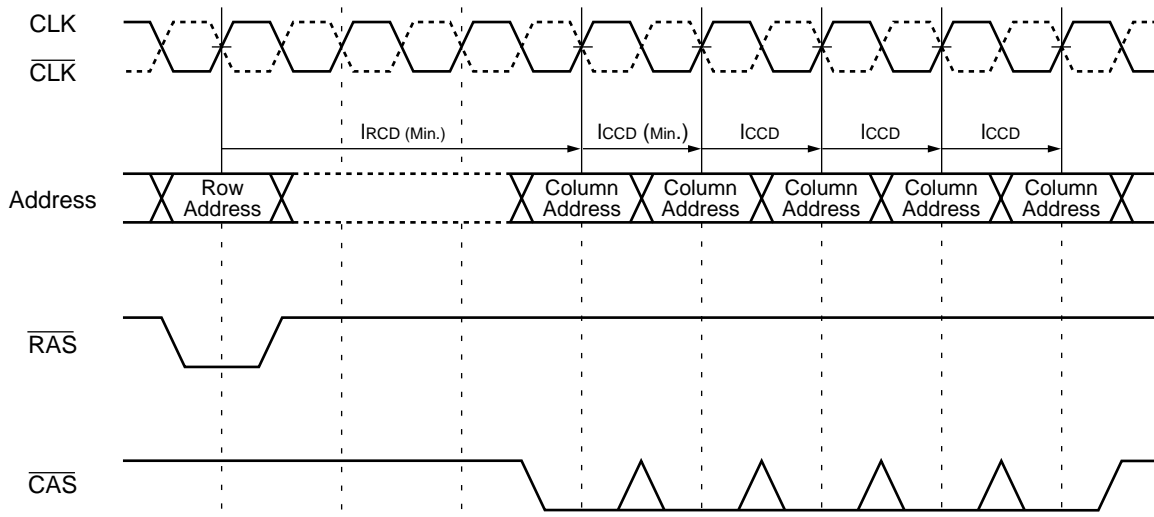

Note:  $t_{CCD}$ ,  $\overline{CAS}$  to  $\overline{CAS}$  address delay, is applicable to the same bank access and it can be one or more clock period.

**TIMING DIAGRAM - 2: DIFFERENT BANK ADDRESS INPUT DELAY**

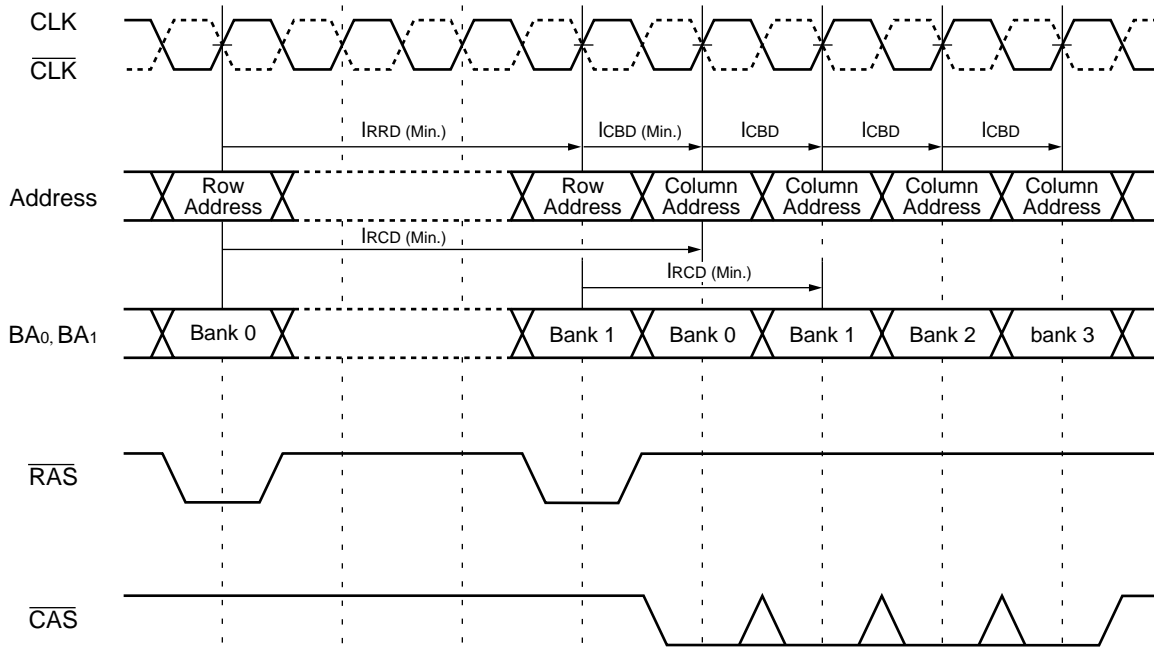

TIMING DIAGRAM - 3: READ (EXAMPLE @ BL = 4)

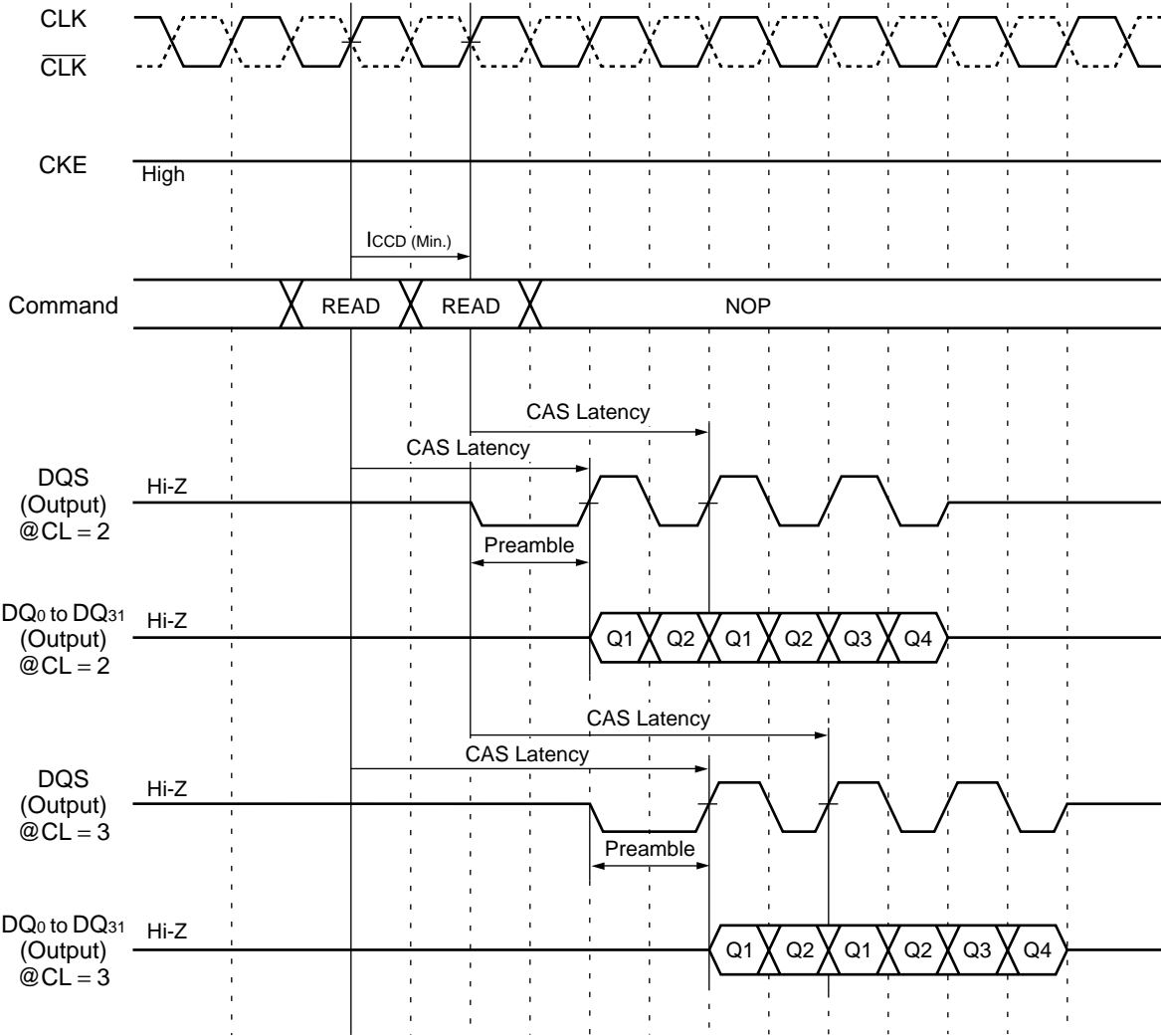

Note: CAS Latency is defined from Read command to first rising edge of DQS<sub>0</sub> to DQS<sub>3</sub> output. Preamble is 1 × t<sub>CK</sub> length and starts driving Low level.

# MB81P643287-50/-60

**TIMING DIAGRAM - 4: WRITE (EXAMPLE @ BL = 4)**

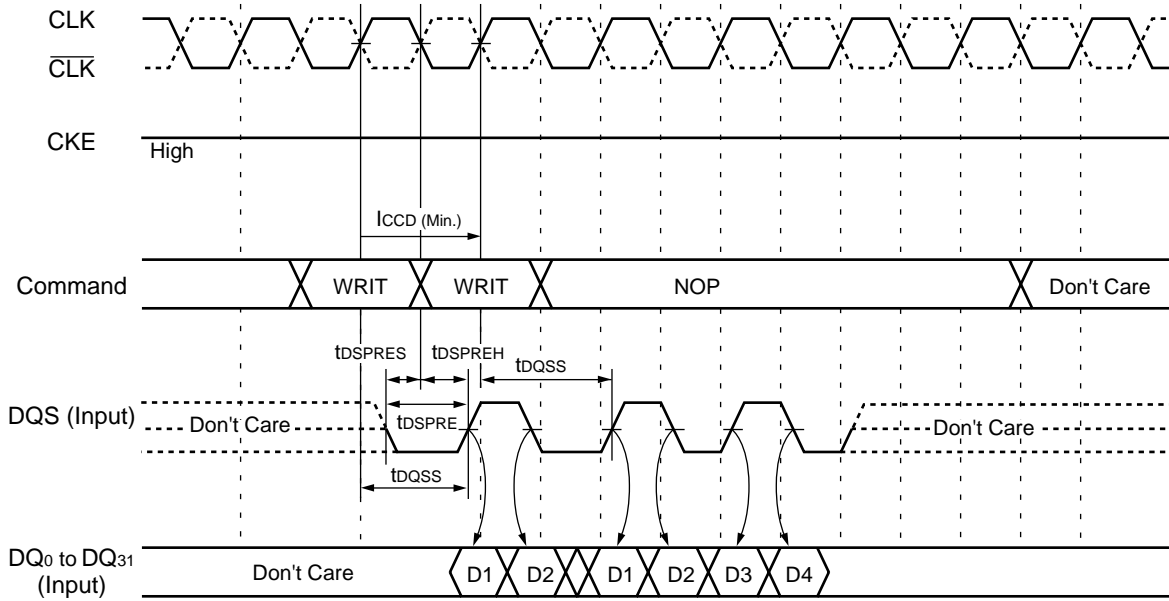

Note: DQS Setup Time,  $t_{dQSS}$ , must be within a range of  $0.75 \cdot t_{CK}$  to  $1.25 \cdot t_{CK}$  from write command Input.

**TIMING DIAGRAM - 5: DM, WRITE DATA MASK (EXAMPLE @ BL = 4)**

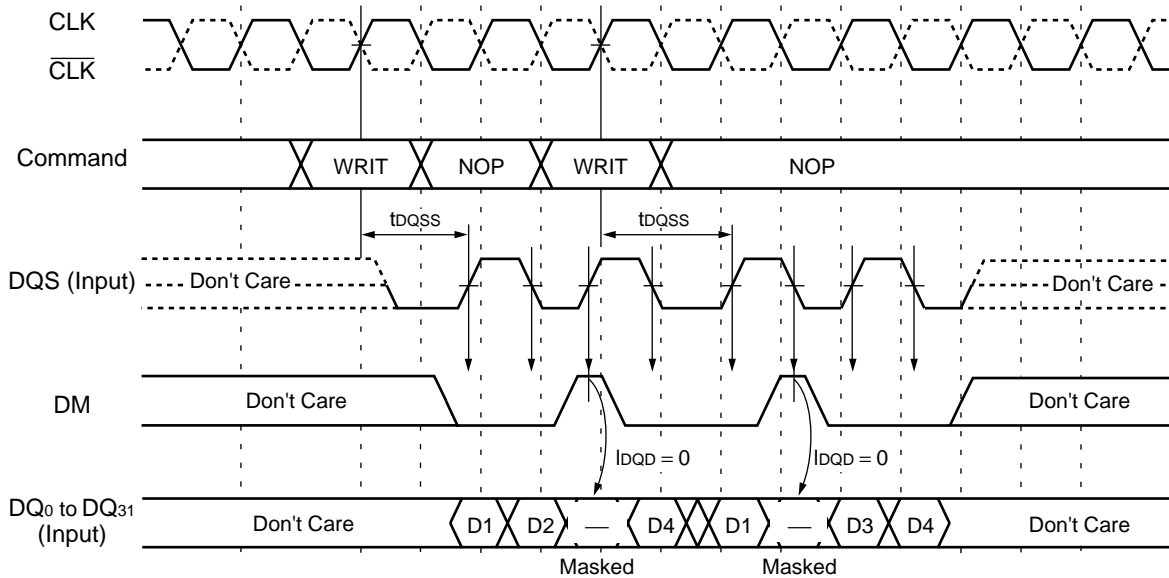

Note: DM are latched by DQS Input together with Data Input after write command.

**TIMING DIAGRAM - 6: READ WITH AUTO-PRECHARGE  
(EXAMPLE @ CL = 2.0, BL = 4 Applied to same bank)**

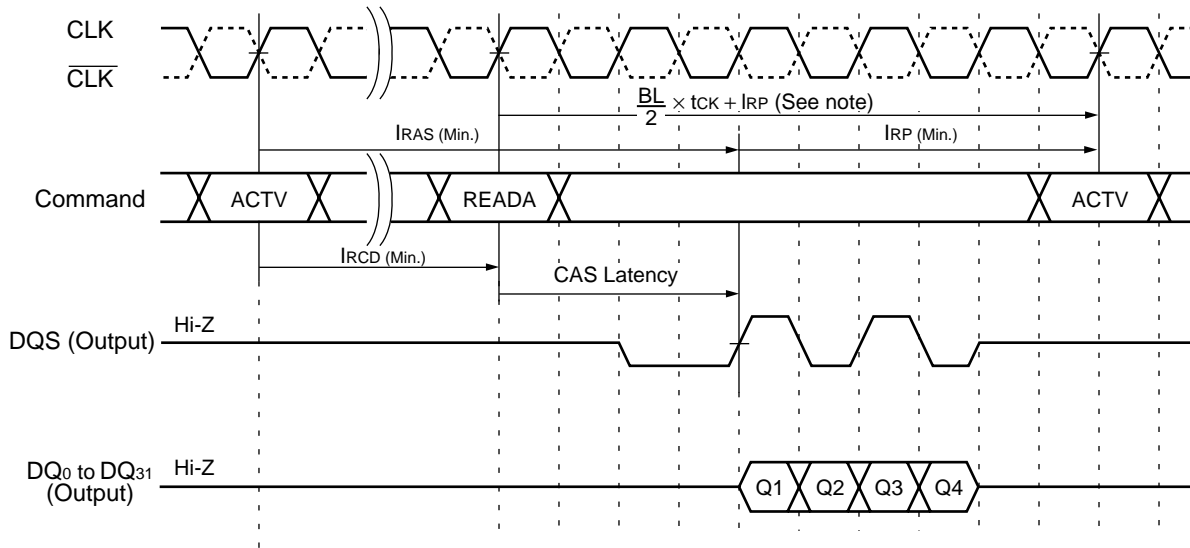

Note: Internal precharge operation at Read with Auto-precharge command (READA) is started  $BL/2$  clock later from READA command.  
 If  $BL=2$ , the READA command should not be issued no earlier than 1 clock ( $BL/2 = 1$ ) before  $I_{RAS}$  (Min.).  
 If  $BL=4$ , the READA command should not be issued no earlier than 2 clock ( $BL/2=2$ ) before  $I_{RAS}$  (Min.).

**TIMING DIAGRAM - 7: WRITE WITH AUTO-PRECHARGE  
(EXAMPLE @ CL = 2.0, BL = 4 Applied to same bank)**

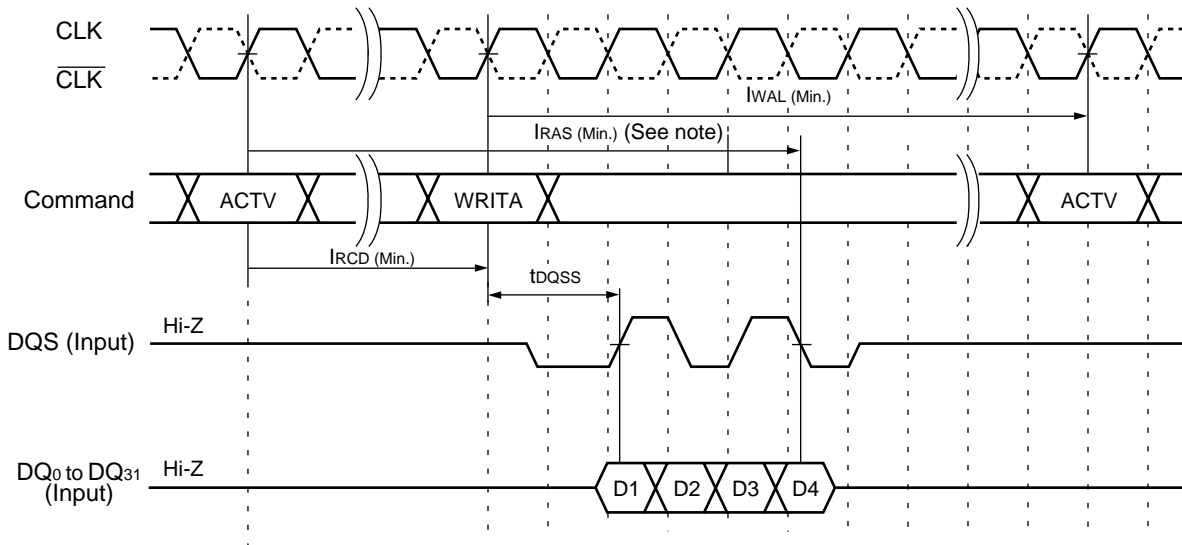

Note: Write with Auto-precharge command (WRITA) must be issued after  $I_{RCD}$  is satisfied and be considered to meet  $I_{RAS}$  requirement applied to end of burst length (BL) regardless of where it is masked or not.

# MB81P643287-50/-60

**TIMING DIAGRAM - 8: READ INTERRUPTED BY PRECHARGE  
(EXAMPLE @ CL = 2, BL = 8)**

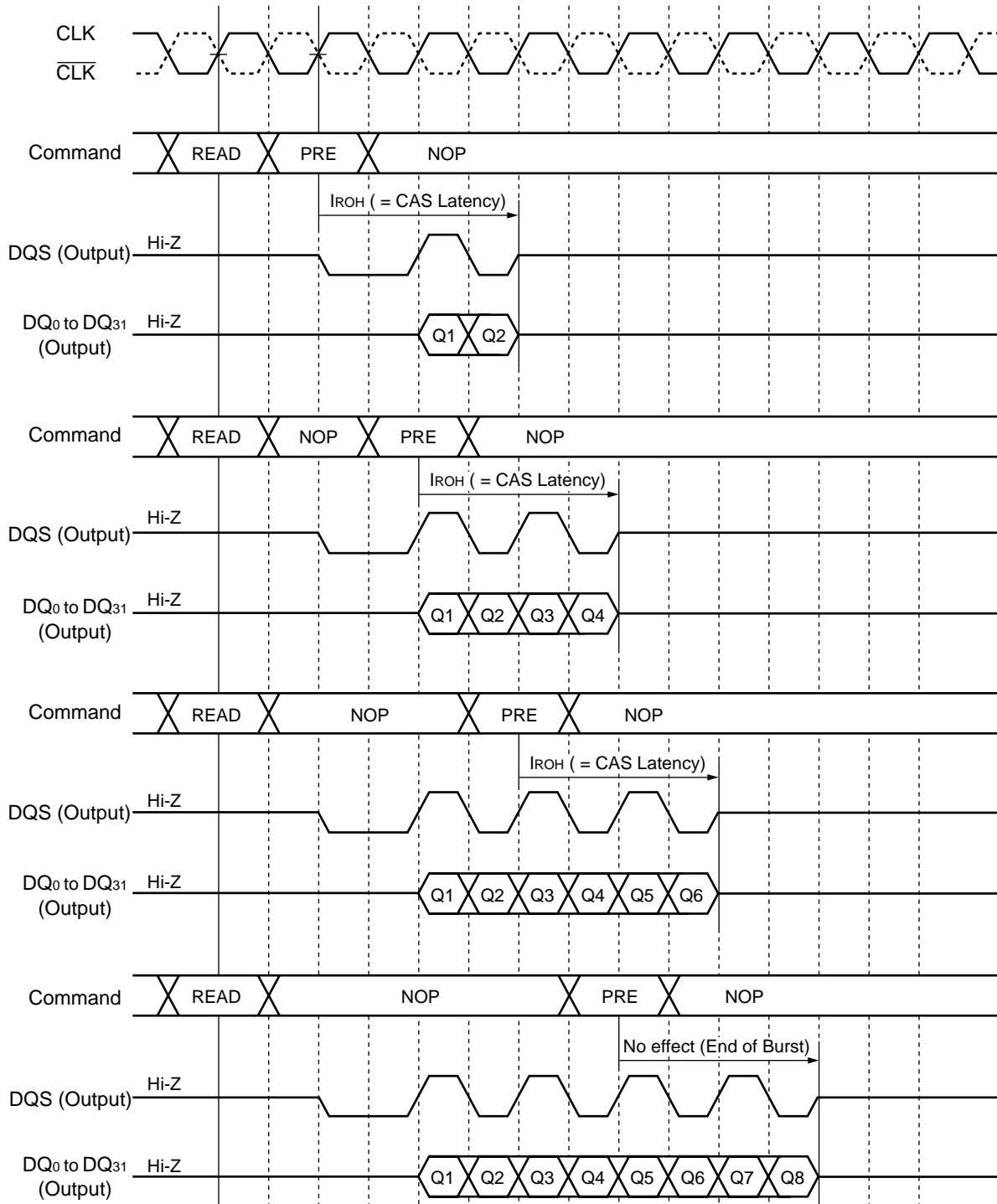

Note:  $I_{ROH}$  is the same as CAS Latency (CL). In case of CL = 3, the  $I_{ROH}$  is 3 clock.

**TIMING DIAGRAM - 9: READ INTERRUPTED BY BURST STOP  
(EXAMPLE @ CL = 2, BL = 8)**

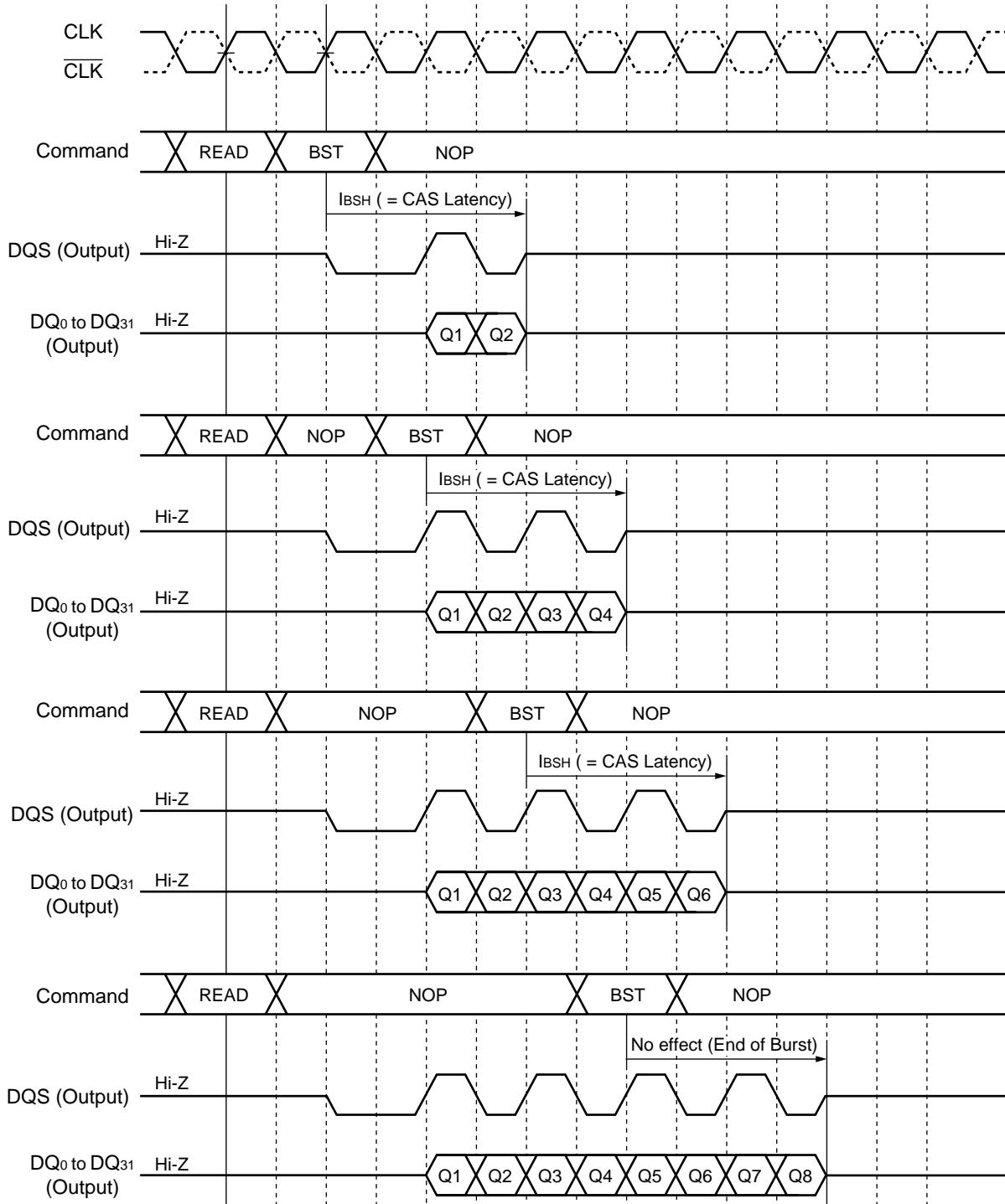

Note:  $t_{BSH}$  is the same as CAS Latency (CL). In case of CL = 3, the  $t_{BSH}$  is 3 clock.

# MB81P643287-50/-60

**TIMING DIAGRAM - 10: WRITE INTERRUPTED BY PRECHARGE (EXAMPLE @ CL = 2, BL = 8)**

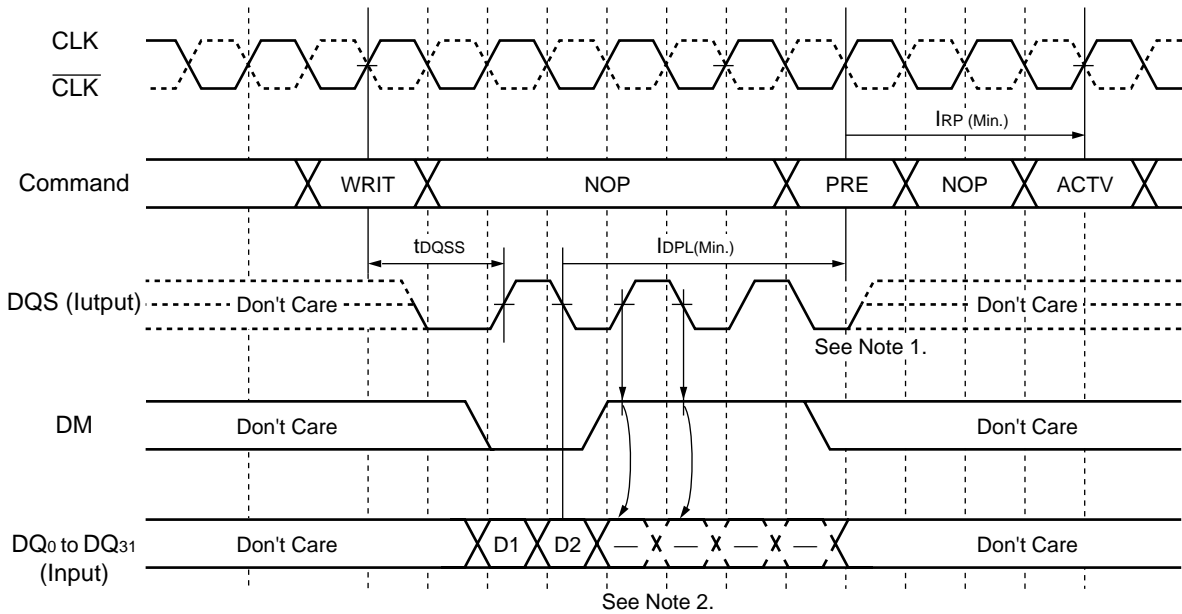

- Note: 1. DQS Input are not required from when Precharge command is issued.  
 2. This pair of write data must be masked prior to Precharge command.

**TIMING DIAGRAM - 11: READ TO WRITE (EXAMPLE @ CL = 2, BL = 4)**

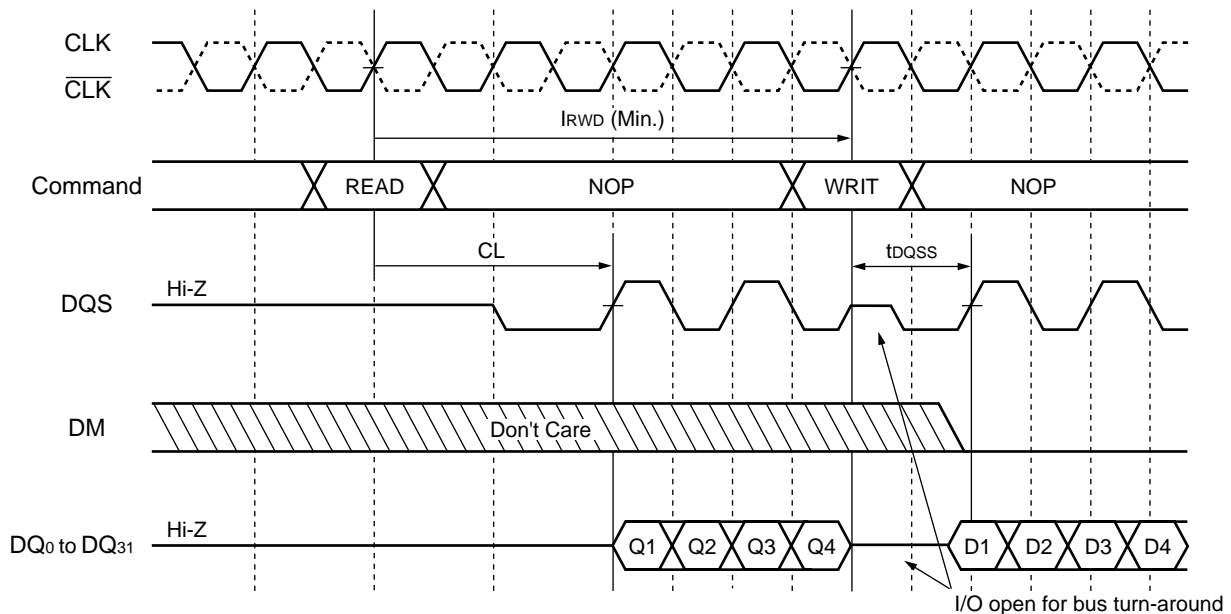

- Note:  $t_{rWD}$  defines a minimum delay from Read to Write command input applied to the same bank.

# MB81P643287-50/-60

**TIMING DIAGRAM - 12: READ TO WRITE (EXAMPLE @ CL = 2, BL = 4)**

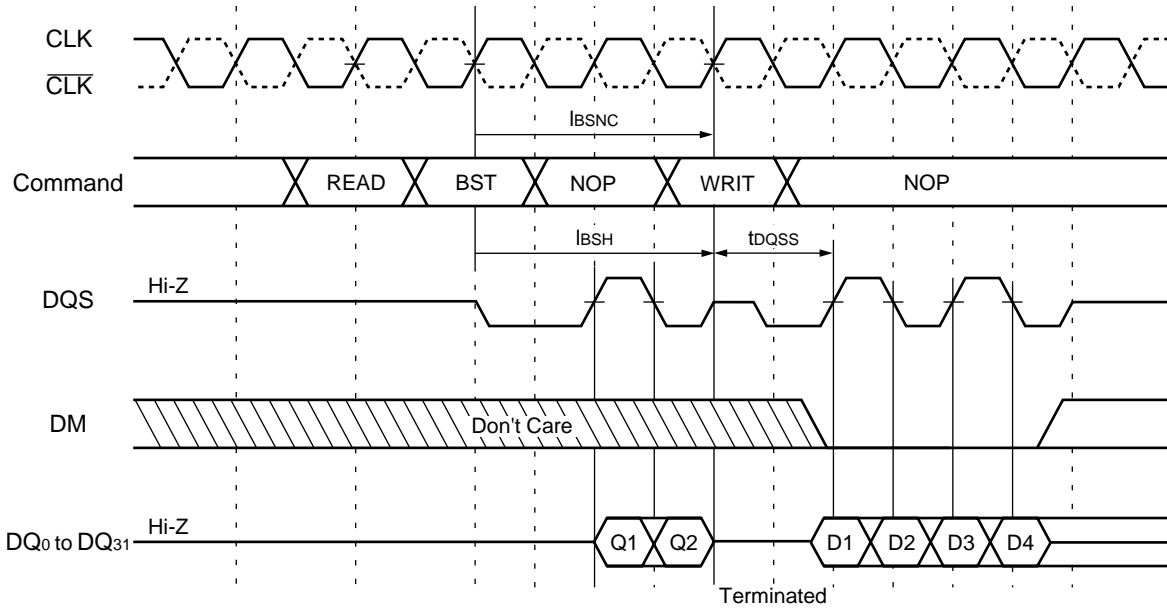

Note: DM are latched by DQS Input after Write command together with data Input.

**TIMING DIAGRAM - 13: WRITE TO READ (EXAMPLE @ CL = 2, BL = 8)**

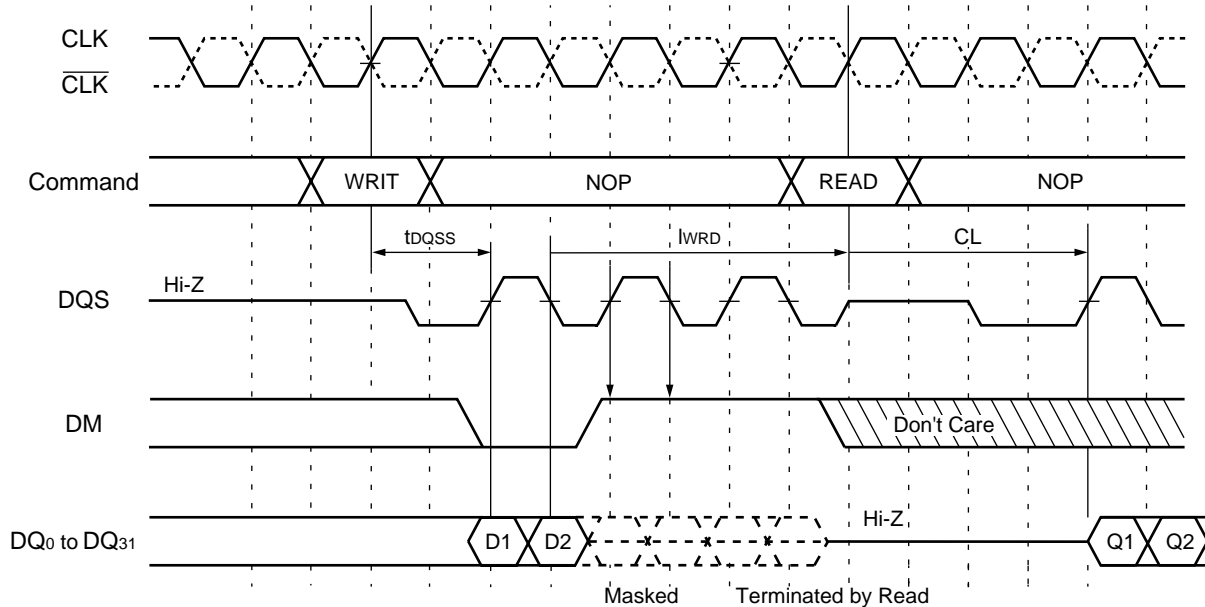

Note: Read command must be issued after lWRD is satisfied and proceeding pair of data must be masked.

# MB81P643287-50/-60

**TIMING DIAGRAM - 14: READ WITH AUTO-PRECHARGE  
(EXAMPLE @ CL = 2, BL = 4, Multiple Bank Operation)**

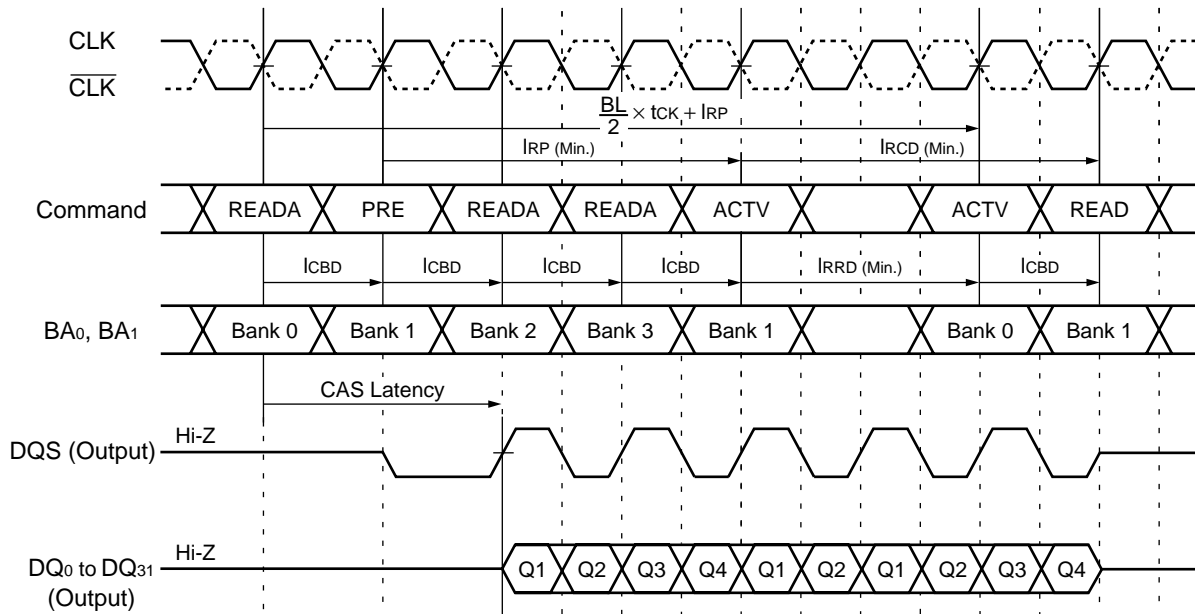

Note: Back to back Read with Auto-precharge (READA) command to the different bank in active state is possible. However, any new command to the same bank applied READA command can only be issued after  $(BL/2) \times t_{CK} + I_{RP}$ .

**TIMING DIAGRAM - 15: WRITE WITH AUTO-PRECHARGE  
(EXAMPLE @ CL = 2, BL = 4, Multiple Bank Operation)**

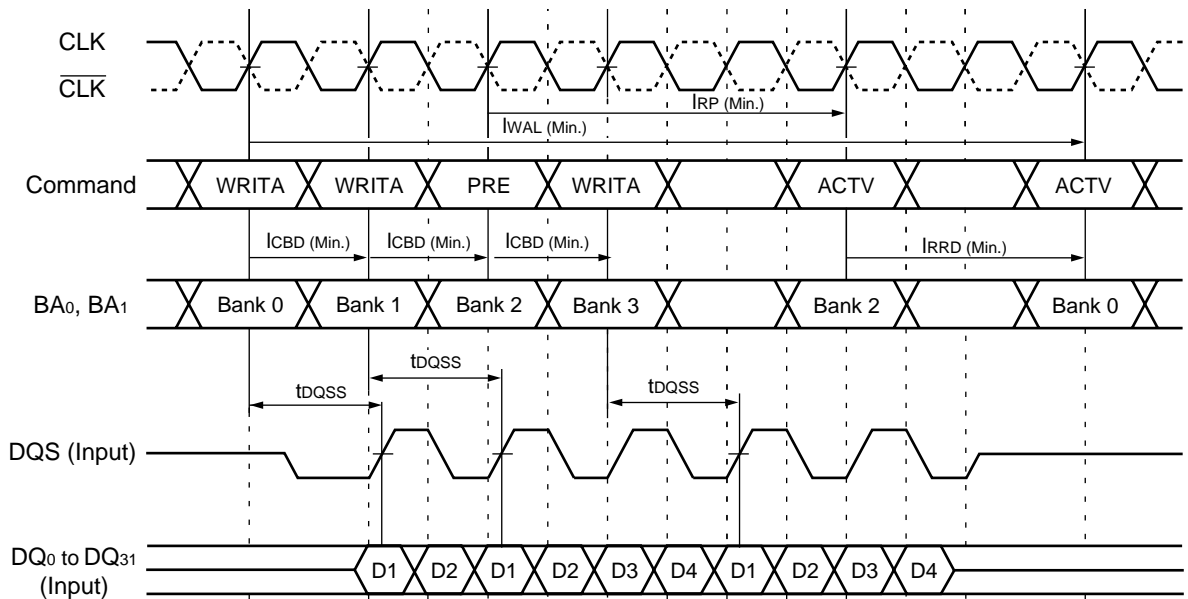

Note: Back to back Write with Auto-precharge (WRITA) command to the different bank in active state is possible. However, any new command to the same bank applied WRITA command can only be issued after  $I_{WAL}$ .

**TIMING DIAGRAM - 16: AUTO-REFRESH ENTRY AND EXIT**

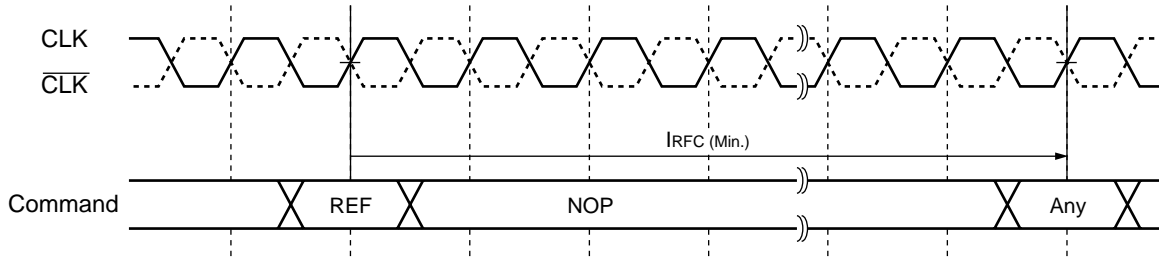

**TIMING DIAGRAM - 17: SELF-REFRESH ENTRY AND EXIT**

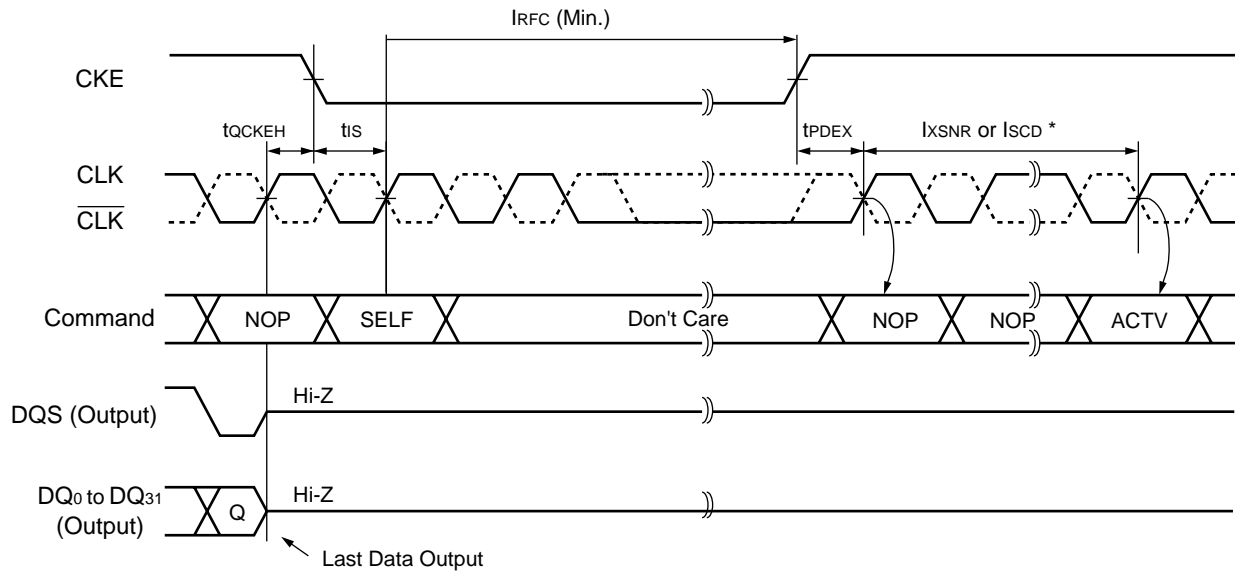

Note \*: CKE must maintain High level and stable clock must be provided during the  $I_{sCD}$  period.  
 After Self-refresh exit,  $I_{xSNR}$  must be satisfied for at least specified period before any command (except for read) input.

**TIMING DIAGRAM - 18: MODE REGISTER SET**

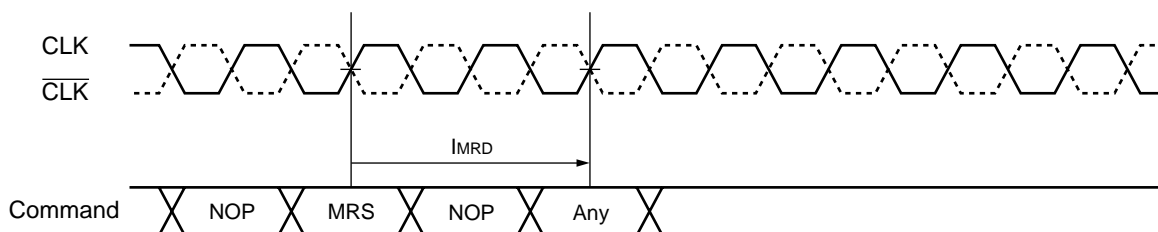

Note: MRS command must be issued after the last data is appeared on each DQ.

# MB81P643287-50/-60

## ■ SCITT TEST MODE

### ABOUT SCITT

SCITT (Static Component Interconnection Test Technology) is an XNOR circuit based test technology that is used for testing interconnection between SDRAM and SDRAM controller on the printed circuit boards. SCITT provides inexpensive board level test mode in combination with boundary-scan. The basic idea is simple, consider all output of SDRAM as output of XNOR circuit and each output pin has a unique mapping on the input of SDRAM. The ideal schematic block diagram is as shown below.

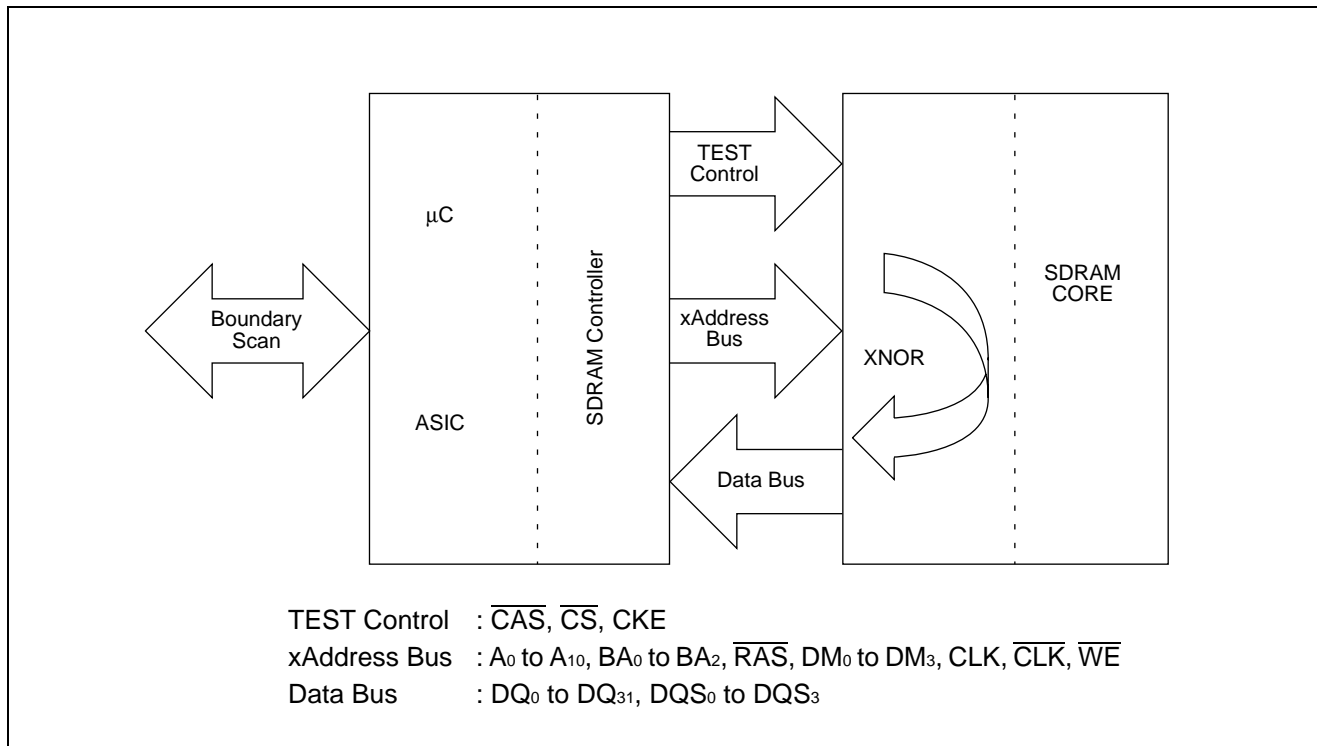

It is static and provides easy test pattern that result in a high diagnostic resolution for detecting all open/short faults.

## SCITT TEST SEQUENCE

The followings are the SCITT test sequence. SCITT Test can be executed after power-on and prior to Precharge command in “■ FUNCTION DESCRIPTION POWER-UP INITIALIZATION”. Once Precharge command is issued to SDRAM, it never get back to SCITT Test Mode during regular operation unless reset power supply for the purpose of a fail-safe way in get in and out of test mode.

1. Maintain all input signals (except CLK,  $\overline{\text{CLK}}$ ) to be Low state (or at least CKE to be Low) and maintain CLK and  $\overline{\text{CLK}}$  to be complementary state.
2. Apply  $V_{\text{DD}}$  voltage to all  $V_{\text{DD}}$  pins before or at the same time as  $V_{\text{DDQ}}$  pins.
3. Apply  $V_{\text{DD}}$  voltage to all  $V_{\text{DDQ}}$  pins before or at the same time as  $V_{\text{REF}}$  and  $V_{\text{TT}}$ .
4. Apply  $V_{\text{REF}}$  and  $V_{\text{TT}}$  ( $V_{\text{TT}}$  is applied to the system).
5. Maintain stable power for a minimum of 100 $\mu\text{s}$ .
6. Enter SCITT test mode.
7. Execute SCITT test.
8. Exit from SCITT mode.

It is required to follow Power On Sequence to execute read or write operation.

9. Start clock after all power supplies reached in a specified operating range and maintain stable condition for a minimum of 200 $\mu\text{s}$ .
10. After the minimum of 200 $\mu\text{s}$  stable power and clock, apply NOP condition and take CKE to be High state.
11. Issue Precharge All Banks (PALL) command or Precharge Single Bank (PRE) command to every banks.
12. Issue EMRS to enable DLL, DE = Low.
13. Issue Mode Register Set command (MRS) to reset DLL, DR = High. An additional clock input for  $I_{\text{PCD}}$ \*1 period is required to lock the DLL.
14. Apply minimum of two Auto-refresh command (REF).\*2
15. Program the mode register by Mode Register Set command (MRS) with DR = Low.\*2

The 6,7,8 steps define the SCITT mode available. It is possible to skip these steps if necessary (Refer to “■ FUNCTION DESCRIPTION POWER-UP INITIALIZATION”).

Notes: \*1. The  $I_{\text{PCD}}$  depends on operating clock period. The  $I_{\text{PCD}}$  is counted from “DLL Reset” at step-13 to any command input at step-15.

\*2. The Mode Register Set command (MRS) can be issued before two Auto-refresh cycle.

# MB81P643287-50/-60

COMMAND TRUTH TABLE Note \*1

	Control			Input						Output	
	$\overline{\text{CAS}}$	$\overline{\text{CS}}$	CKE	$\overline{\text{WE}}$	$\overline{\text{RAS}}$	A <sub>0</sub> to A <sub>10</sub> , BA <sub>0</sub> to BA <sub>2</sub>	DM <sub>0</sub> to DM <sub>3</sub>	CLK	$\overline{\text{CLK}}$	DQ <sub>0</sub> to DQ <sub>31</sub>	DQS <sub>0</sub> to DQS <sub>3</sub>
SCITT mode entry	H→L *2	L	L	X	X	X	X	H	L	X	X
								L	H		
SCITT mode exit	L→H *3	H *5	L *5	X	X	X	X	X	X	X	X
SCITT mode output enable *4	L	L	H	V	V	V	V	V	V	V	V

- Notes: \*1. L = Logic Low, H = Logic High, V = Valid, X = either L or H  
 \*2. The SCITT mode entry command assumes the first  $\overline{\text{CAS}}$  falling edge with  $\overline{\text{CS}} = \text{CKE} = \text{L}$  and CLK,  $\overline{\text{CLK}}$  signals are complementary after power on.  
 \*3. The SCITT mode exit command assumes the first  $\overline{\text{CAS}}$  rising edge after the test mode entry.  
 \*4. Refer the test code table.  
 \*5.  $\overline{\text{CS}} = \text{H}$  or CKE = L is necessary to disable outputs in SCITT mode exit.



# MB81P643287-50/-60

## AC SPECIFICATION

Parameter	Description	Min.	Max.	Units
t <sub>TS</sub>	Test mode entry set up time	10	—	ns
t <sub>TH</sub>	Test mode entry hold time	10	—	ns
t <sub>EPD</sub>	Test mode exit to power on sequence delay time	10	—	ns
t <sub>TLZ</sub>	$\overline{CS}$ , CKE to output in Low-Z time	0	—	ns
t <sub>THZ</sub>	$\overline{CS}$ , CKE to output in High-Z time	0	20	ns
t <sub>TCA</sub>	Test mode access time from control signals (clock enable & chip select)	—	40	ns
t <sub>TIA</sub>	Test mode Input access time	—	20	ns
t <sub>TOH</sub>	Test mode Output Hold time	0	—	ns
t <sub>ETD</sub>	Test mode entry to test delay time	10	—	ns
t <sub>TIH</sub>	Test mode input hold time	30	—	ns

# MB81P643287-50/-60

## TIMING DIAGRAMS

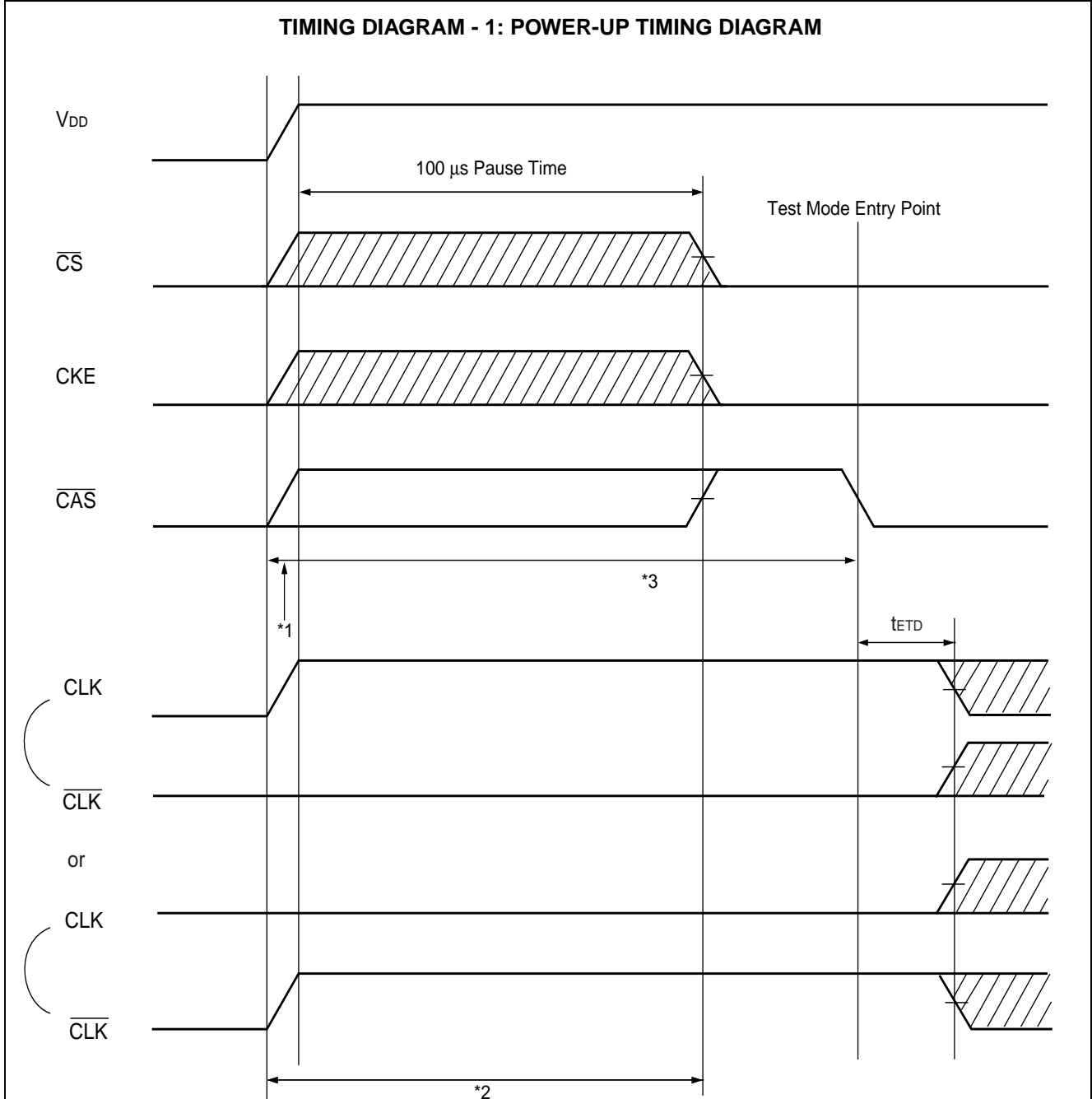

- Notes:
- \*1.  $\overline{\text{CAS}}$  shall be staid either High or Low at power on.
  - \*2. All output buffers maintains in High-Z state regardless of the state of control signals except for  $\overline{\text{CAS}}$  as long as the above timing is maintained.
  - \*3.  $\overline{\text{CAS}}$  must not be brought from High to Low.

# MB81P643287-50/-60

TIMING DIAGRAM - 2 : SCITT TEST ENTRY AND EXIT \*1

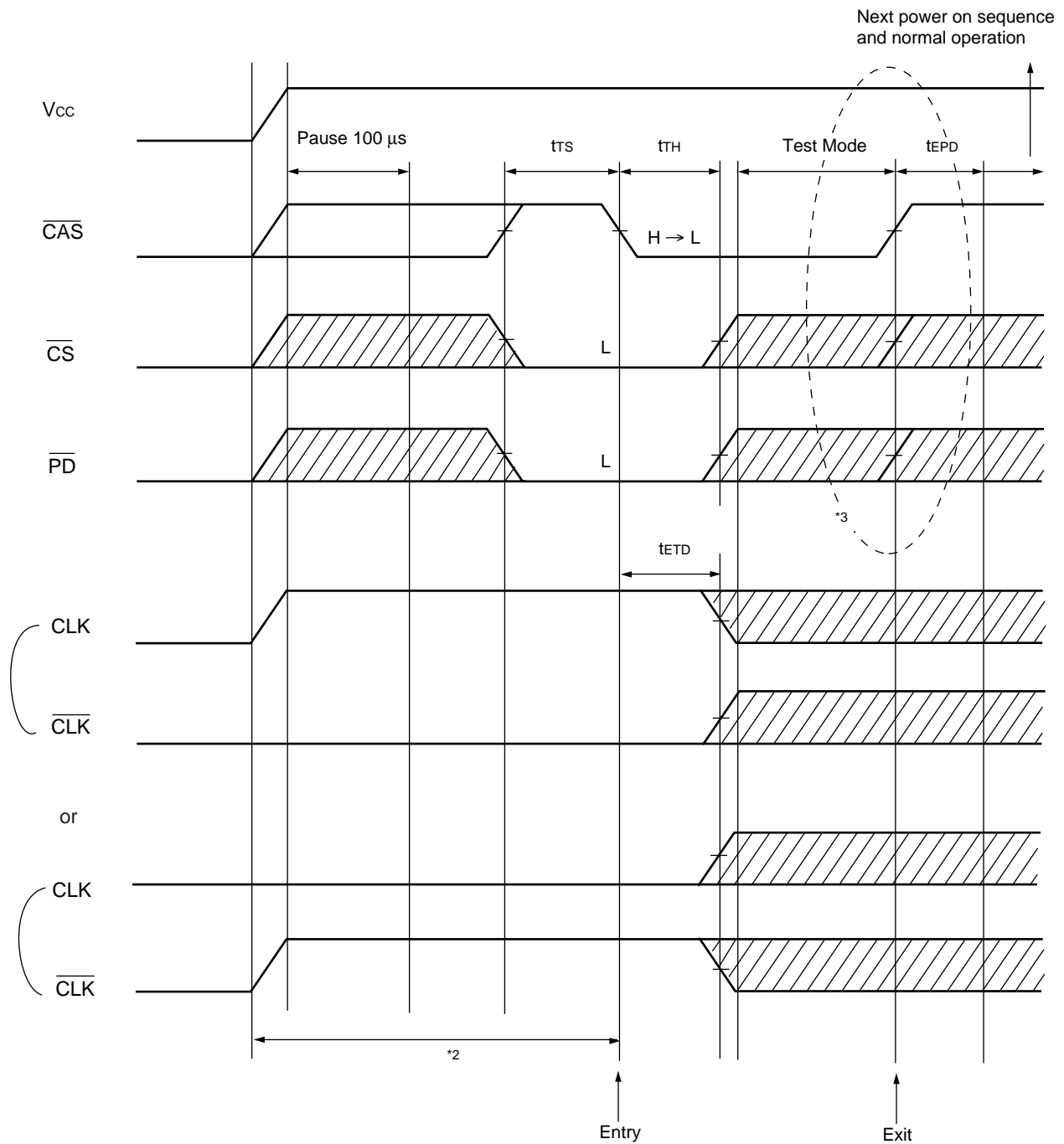

- Notes: \*1. If entry and exit operation have not been done correctly,  $\overline{CAS}$ ,  $\overline{CS}$ , CKE pins will have some problems.  
 \*2. PRE or PALL commands must not be asserted. Test mode is disabled by those commands.  
 \*3. Outputs must be disabled by  $\overline{CS} = H$  or  $CKE = L$  before Exit.

### TIMING DIAGRAM - 3: OUTPUT CONTROL (1)

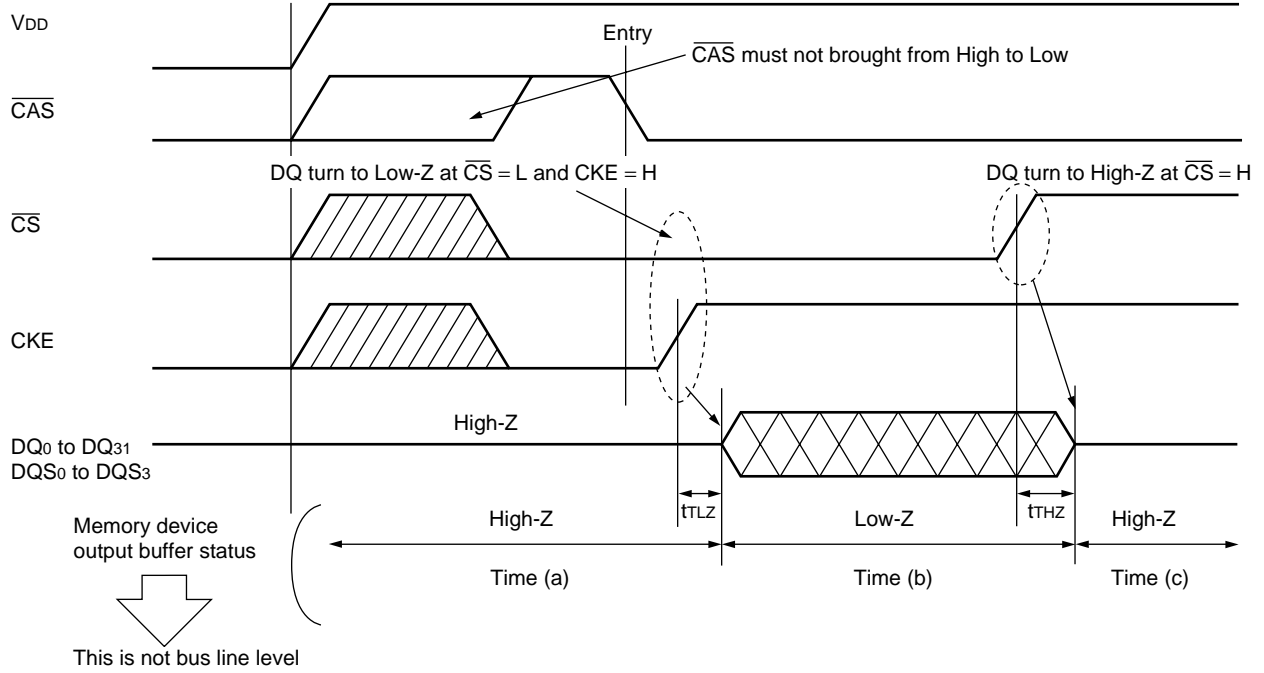

### TIMING DIAGRAM - 4: OUTPUT CONTROL (2)

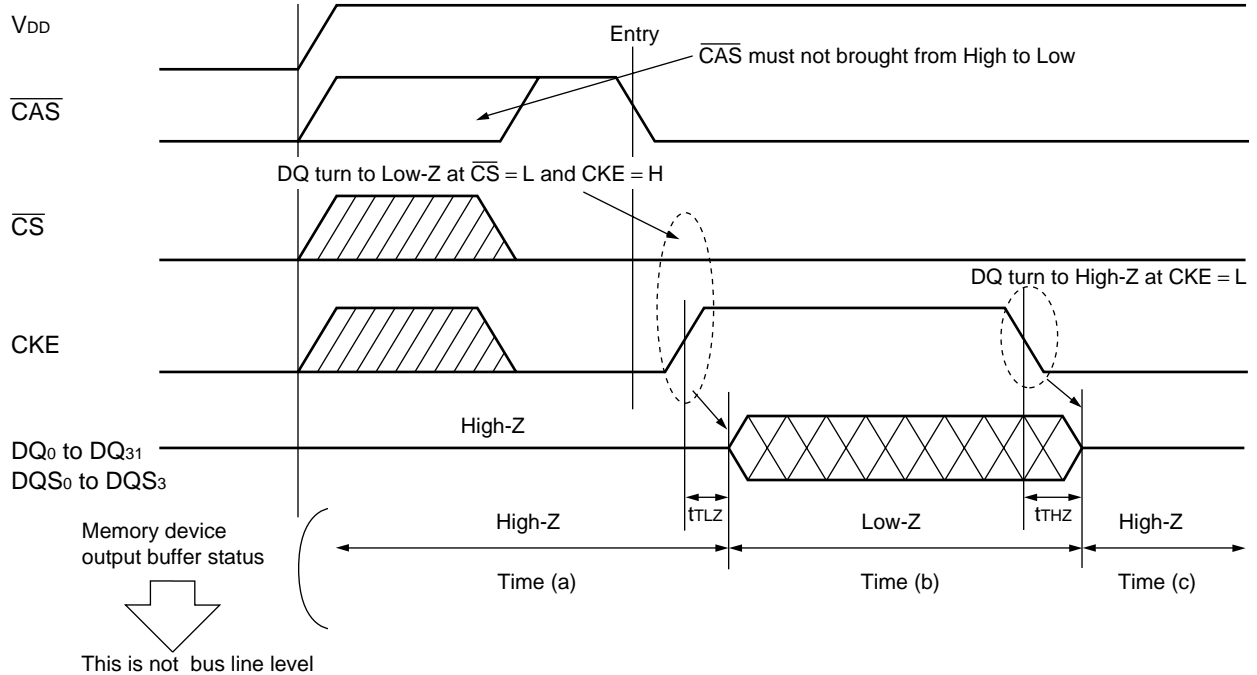

# MB81P643287-50/-60

**TIMING DIAGRAM - 5: TEST TIMING (1)**

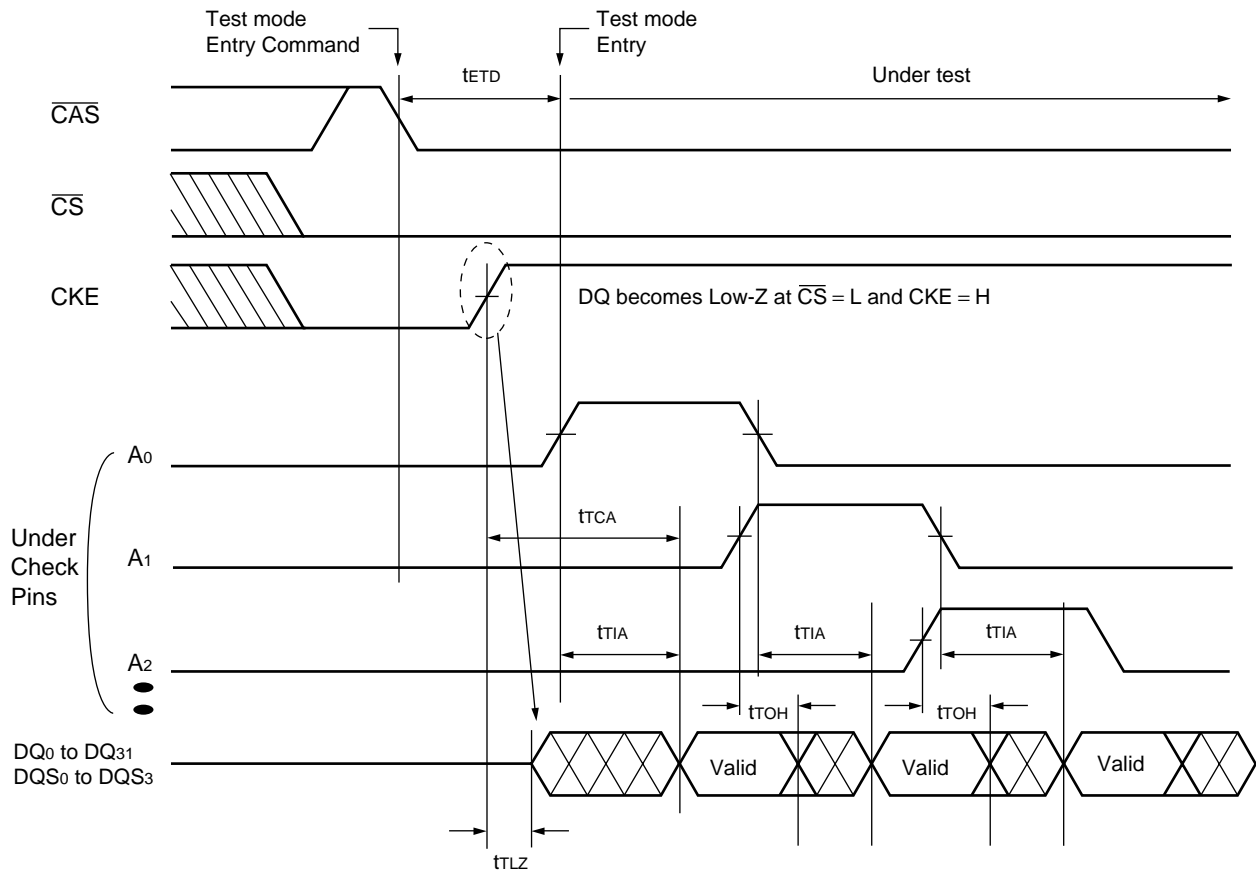

# MB81P643287-50/-60

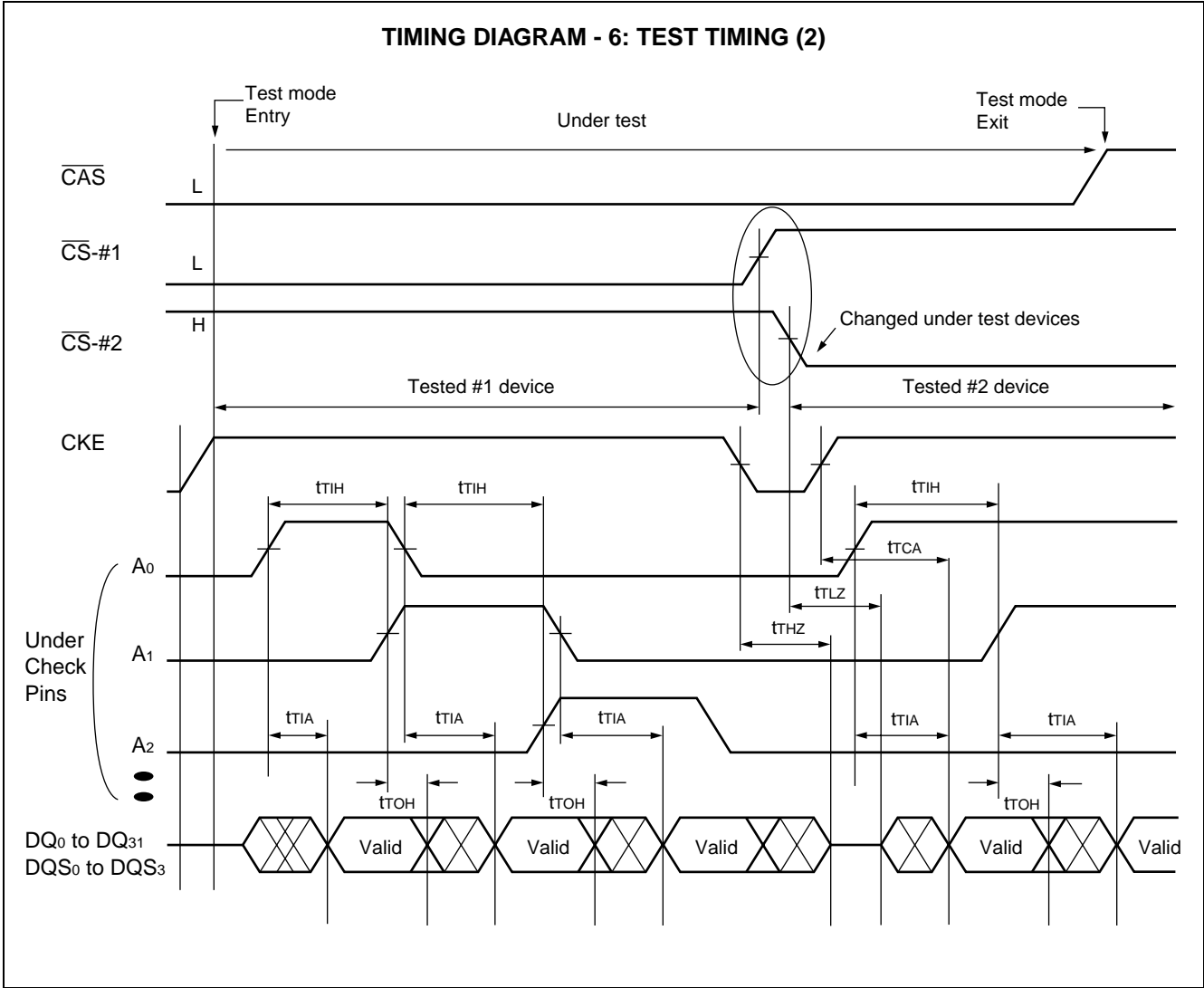

# MB81P643287-50/-60

## TIMING DIAGRAM - 7: TEST TIMING (3)

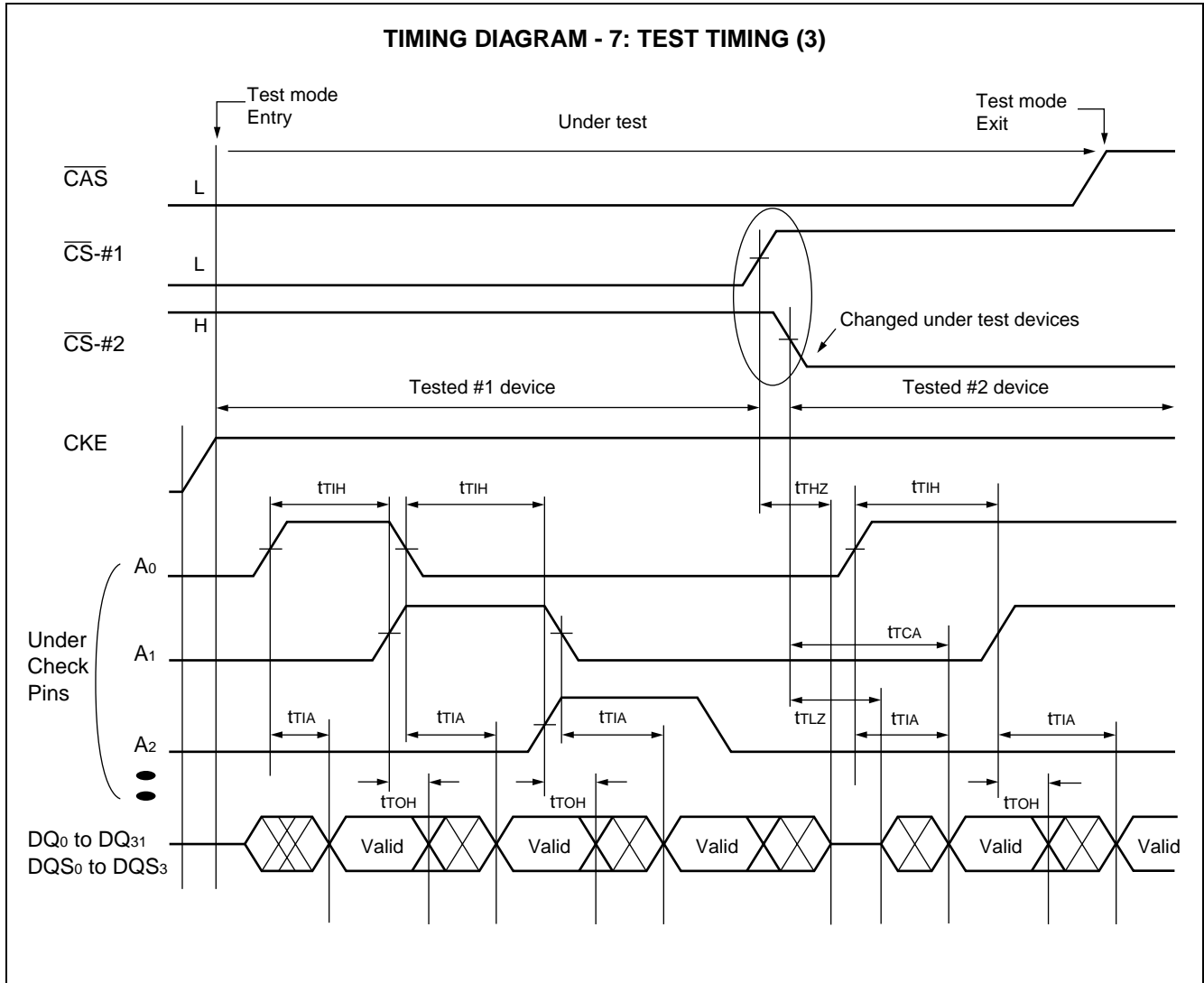

# MB81P643287-50/-60

## ■ ORDERING INFORMATION

Part number	Package	Remarks
MB81P643287-50FN	86-pin plastic TSOP(II) (FPT-86P-M01)	—
MB81P643287-60FN		

# MB81P643287-50/-60

## ■ PACKAGE DIMENSIONS

86-pin plastic TSOP (II)  
(FPT-86P-M01)

\*: Resin protrusion.(Each side: 0.15 (.006) Max.)

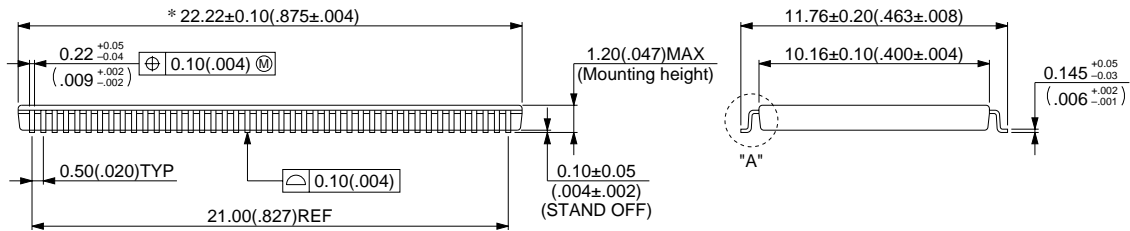
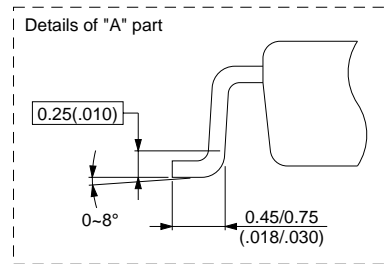
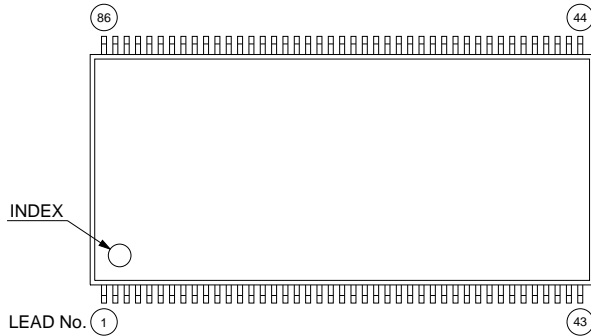

© 1996 FUJITSU LIMITED F86001S-1C-1

Dimensions in mm (inches).

# MB81P643287-50/-60

## FUJITSU LIMITED

*For further information please contact:*

### **Japan**

FUJITSU LIMITED  
Corporate Global Business Support Division  
Electronic Devices  
Shinjuku Dai-Ichi Seimei Bldg. 7-1,  
Nishishinjuku 2-chome, Shinjuku-ku,  
Tokyo 163-0721, Japan  
Tel: +81-3-5322-3347  
Fax: +81-3-5322-3386

<http://www.fujitsu.co.jp/>

### **North and South America**

FUJITSU MICROELECTRONICS, INC.  
3545 North First Street,  
San Jose, CA 95134-1804, U.S.A.  
Tel: +1-408-922-9000  
Fax: +1-408-922-9179

Customer Response Center  
*Mon. - Fri.: 7 am - 5 pm (PST)*  
Tel: +1-800-866-8608  
Fax: +1-408-922-9179

<http://www.fujitsumicro.com/>

### **Europe**

FUJITSU MICROELECTRONICS EUROPE GmbH  
Am Siebenstein 6-10,  
D-63303 Dreieich-Buchsschlag,  
Germany  
Tel: +49-6103-690-0  
Fax: +49-6103-690-122

<http://www.fujitsu-fme.com/>

### **Asia Pacific**

FUJITSU MICROELECTRONICS ASIA PTE. LTD.  
#05-08, 151 Lorong Chuan,  
New Tech Park,  
Singapore 556741  
Tel: +65-281-0770  
Fax: +65-281-0220

<http://www.fmap.com.sg/>

### **Korea**

FUJITSU MICROELECTRONICS KOREA LTD.  
1702 KOSMO TOWER, 1002 Daechi-Dong,  
Kangnam-Gu, Seoul 135-280  
Korea  
Tel: +82-2-3484-7100  
Fax: +82-2-3484-7111

All Rights Reserved.

The contents of this document are subject to change without notice. Customers are advised to consult with FUJITSU sales representatives before ordering.

The information and circuit diagrams in this document are presented as examples of semiconductor device applications, and are not intended to be incorporated in devices for actual use. Also, FUJITSU is unable to assume responsibility for infringement of any patent rights or other rights of third parties arising from the use of this information or circuit diagrams.

The contents of this document may not be reproduced or copied without the permission of FUJITSU LIMITED.

FUJITSU semiconductor devices are intended for use in standard applications (computers, office automation and other office equipments, industrial, communications, and measurement equipments, personal or household devices, etc.).

#### **CAUTION:**

Customers considering the use of our products in special applications where failure or abnormal operation may directly affect human lives or cause physical injury or property damage, or where extremely high levels of reliability are demanded (such as aerospace systems, atomic energy controls, sea floor repeaters, vehicle operating controls, medical devices for life support, etc.) are requested to consult with FUJITSU sales representatives before such use. The company will not be responsible for damages arising from such use without prior approval.

Any semiconductor devices have inherently a certain rate of failure. You must protect against injury, damage or loss from such failures by incorporating safety design measures into your facility and equipment such as redundancy, fire protection, and prevention of over-current levels and other abnormal operating conditions.

If any products described in this document represent goods or technologies subject to certain restrictions on export under the Foreign Exchange and Foreign Trade Control Law of Japan, the prior authorization by Japanese government should be required for export of those products from Japan.