

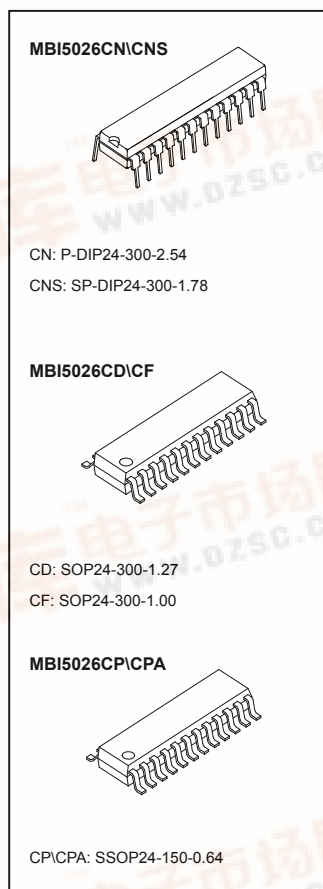

16-bit Constant Current LED Sink Driver

Features

- 16 constant-current output channels
- Constant output current invariant to load voltage change
- Excellent output current accuracy:
between channels: $<\pm 3\%$ (max.), and
between ICs: $<\pm 6\%$ (max.)
- Output current adjusted through an external resistor
- Constant output current range: 5-90 mA
- Fast response of output current, \overline{OE} (min.): 200 ns
- 25MHz clock frequency
- Schmitt trigger input
- 5V supply voltage



Current Accuracy		Conditions
Between Channels	Between ICs	
$< \pm 3\%$	$< \pm 6\%$	$I_{OUT} = 10 \sim 60 \text{ mA}$

Product Description

MBI5026 is designed for LED displays. As an enhancement of its predecessor, MBI5016, MBI5026 exploits PrecisionDrive™ technology to enhance its output characteristics. MBI5026 contains a serial buffer and data latches which convert serial input data into parallel output format. At MBI5026 output stage, sixteen regulated current ports are designed to provide uniform and constant current sinks for driving LEDs within a large range of Vf variations.

MBI5026 provides users with great flexibility and device performance while using MBI5026 in their system design for LED display applications, e.g. LED panels. Users may adjust the output current from 5 mA to 90 mA through an external resistor, R_{ext} , which gives users flexibility in controlling the light intensity of LEDs. MBI5026 guarantees to endure maximum 17V at the output port. The high clock frequency, 25 MHz, also satisfies the system requirements of high volume data transmission.



Block Diagram

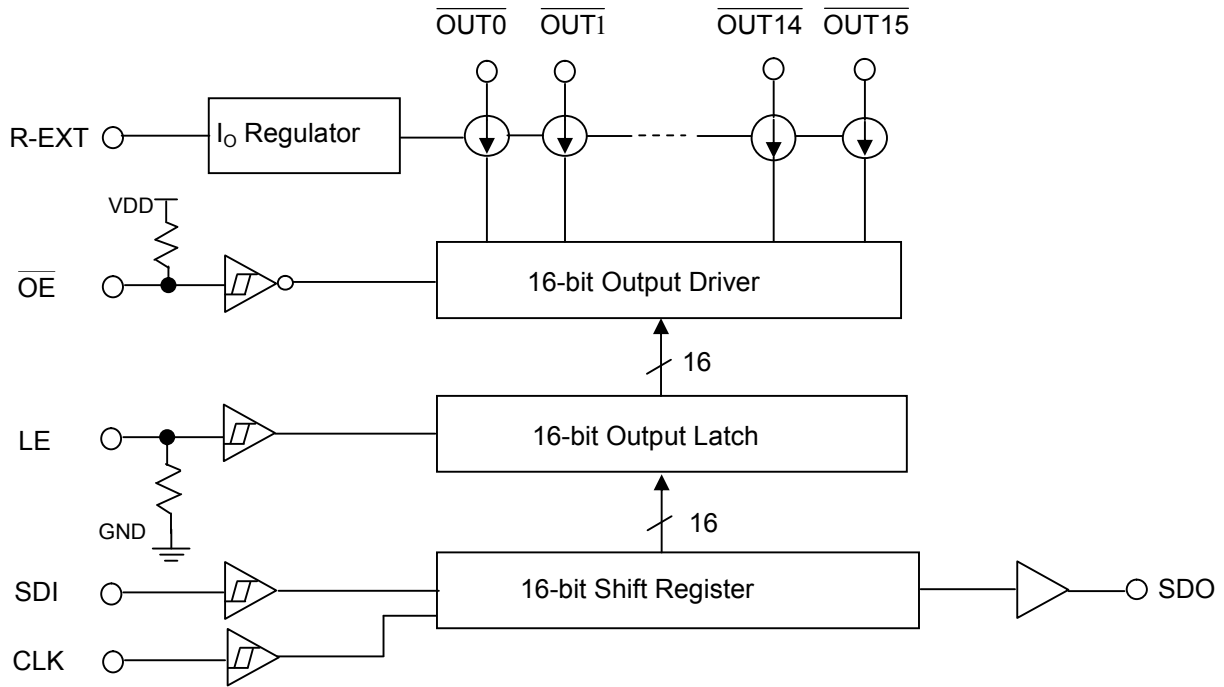

Terminal Description

Pin Name	Function
GND	Ground terminal for control logic and current sink
SDI	Serial-data input to the shift register
CLK	Clock input terminal for data shift on rising edge
LE	Data strobe input terminal Serial data is transferred to the output latch when LE is high. The data is latched when LE goes low.
$\overline{\text{OUT0}} \sim \overline{\text{OUT15}}$	Constant current output terminals
$\overline{\text{OE}}$	Output enable terminal When $\overline{\text{OE}}$ (active) low, the output drivers are enabled; when $\overline{\text{OE}}$ high, all output drivers are turned OFF (blanked).
SDO	Serial-data output to the following SDI of next driver IC
R-EXT	Input terminal used to connect an external resistor for setting up output current for all output channels
VDD	5V supply voltage terminal

Pin Configuration

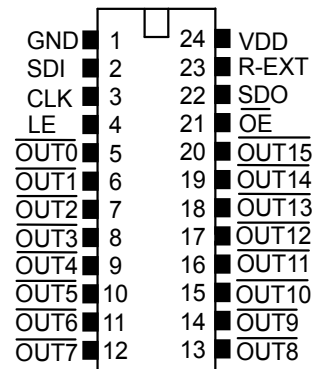

MBI5026CNCNSICDIFCP

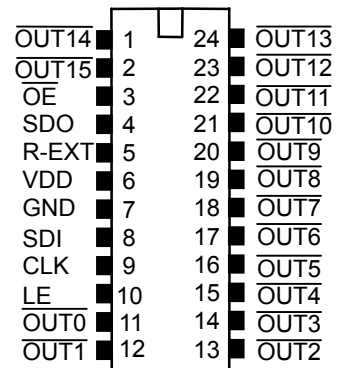

MBI5026CPA

Equivalent Circuits of Inputs and Outputs

\overline{OE} terminal

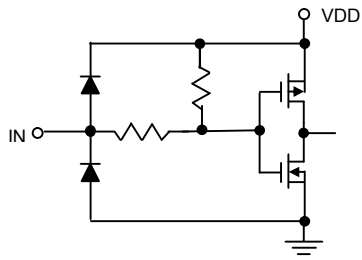

LE terminal

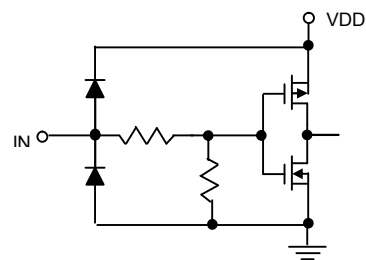

CLK, SDI terminal

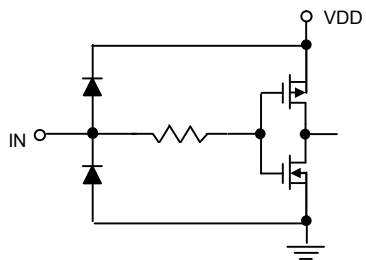

SDO terminal

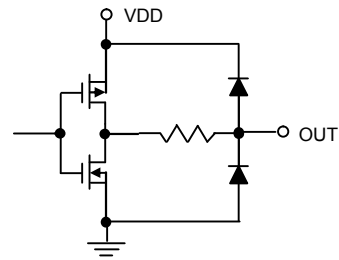

Timing Diagram

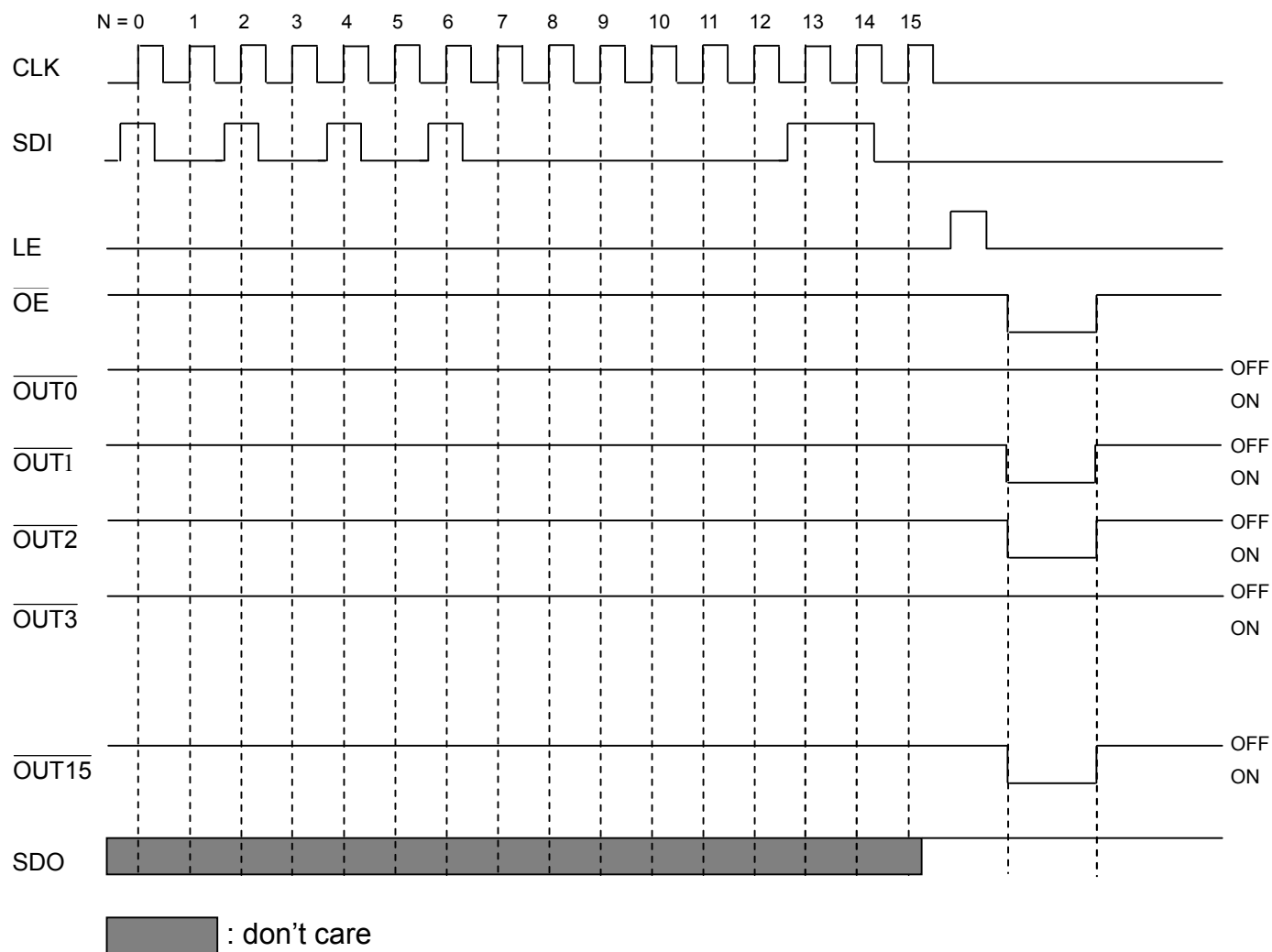

Truth Table

CLK	LE	OE	SDI	OUT0 ... OUT7 ... OUT15	SDO
	H	L	D_n	$\overline{D_n} \dots \overline{D_{n-7}} \dots \overline{D_{n-15}}$	D_{n-15}
	L	L	D_{n+1}	No Change	D_{n-14}
	H	L	D_{n+2}	$\overline{D_{n+2}} \dots \overline{D_{n-5}} \dots \overline{D_{n-13}}$	D_{n-13}
	X	L	D_{n+3}	$\overline{D_{n+2}} \dots \overline{D_{n-5}} \dots \overline{D_{n-13}}$	D_{n-13}
	X	H	D_{n+3}	Off	D_{n-13}

Maximum Ratings

Characteristic		Symbol	Rating	Unit
Supply Voltage		V_{DD}	0~7.0	V
Input Voltage		V_{IN}	-0.4~ $V_{DD} + 0.4$	V
Output Current		I_{OUT}	+90	mA
Output Voltage		V_{DS}	-0.5~+20.0	V
Clock Frequency		F_{CLK}	25	MHz
GND Terminal Current		I_{GND}	1440	mA
Power Dissipation (On PCB, $T_a=25^{\circ}C$)	CN – type	P_D	2.32	W
	CNS – type		1.87	
	CD – type		2.51	
	CF – type		2.12	
	CP – type		1.73	
	CPA – type		1.73	
Thermal Resistance (On PCB, $T_a=25^{\circ}C$)	CN – type	$R_{th(j-a)}$	53.82	$^{\circ}C/W$
	CNS – type		66.74	
	CD – type		49.81	
	CF – type		59.01	
	CP – type		72.43	
	CPA – type		72.43	
Operating Temperature		T_{opr}	-40~+85	$^{\circ}C$
Storage Temperature		T_{stg}	-55~+150	$^{\circ}C$

Electrical Characteristics

Characteristic		Symbol	Condition	Min.	Typ.	Max.	Unit
Supply Voltage		V_{DD}	-	4.5	5.0	5.5	V
Output Voltage		V_{DS}	$\overline{OUT0} \sim \overline{OUT15}$	-	-	17.0	V
Output Current		I_{OUT}	DC Test Circuit	5	-	90	mA
		I_{OH}	SDO	-	-	-1.0	mA
		I_{OL}	SDO	-	-	1.0	mA
Input Voltage	"H" level	V_{IH}	$T_a = -40 \sim 85^\circ C$	$0.8V_{DD}$	-	V_{DD}	V
	"L" level	V_{IL}	$T_a = -40 \sim 85^\circ C$	GND	-	$0.3V_{DD}$	V
Output Leakage Current		I_{OH}	$V_{OH}=17.0V$	-	-	0.5	μA
Output Voltage	SDO	V_{OL}	$I_{OL}=+1.0mA$	-	-	0.4	V
		V_{OH}	$I_{OH}=-1.0mA$	4.6	-	-	V
Output Current 1		I_{OUT1}	$V_{DS}=0.6V$ $R_{ext}=720 \Omega$	-	26.25	-	mA
Current Skew		dI_{OUT1}	$I_{OL}=26.25mA$ $V_{DS}=0.6V$ $R_{ext}=720 \Omega$	-	± 1	± 3	%
Output Current 2		I_{OUT2}	$V_{DS}=0.8V$ $R_{ext}=360 \Omega$	-	52.5	-	mA
Current Skew		dI_{OUT2}	$I_{OL}=52.5mA$ $V_{DS}=0.8V$ $R_{ext}=360 \Omega$	-	± 1	± 3	%
Output Current vs. Output Voltage Regulation		$\%/dV_{DS}$	V_{DS} within 1.0V and 3.0V	-	± 0.1	-	% / V
Output Current vs. Supply Voltage Regulation		$\%/dV_{DD}$	V_{DD} within 4.5V and 5.5V	-	± 1	-	% / V
Pull-up Resistor		$R_{IN(up)}$	\overline{OE}	250	500	800	K Ω
Pull-down Resistor		$R_{IN(down)}$	LE	250	500	800	K Ω
Supply Current	"OFF"	$I_{DD(off) 1}$	$R_{ext}=\text{Open}, \overline{OUT0} \sim \overline{OUT15} =\text{Off}$	-	7	12	mA
		$I_{DD(off) 2}$	$R_{ext}=720 \Omega, \overline{OUT0} \sim \overline{OUT15} =\text{Off}$	-	10	12	
		$I_{DD(off) 3}$	$R_{ext}=360 \Omega, \overline{OUT0} \sim \overline{OUT15} =\text{Off}$	-	12	15	
	"ON"	$I_{DD(on) 1}$	$R_{ext}=720 \Omega, \overline{OUT0} \sim \overline{OUT15} =\text{On}$	-	10	18	
		$I_{DD(on) 2}$	$R_{ext}=360 \Omega, \overline{OUT0} \sim \overline{OUT15} =\text{On}$	-	12	20	

Test Circuit for Electrical Characteristics

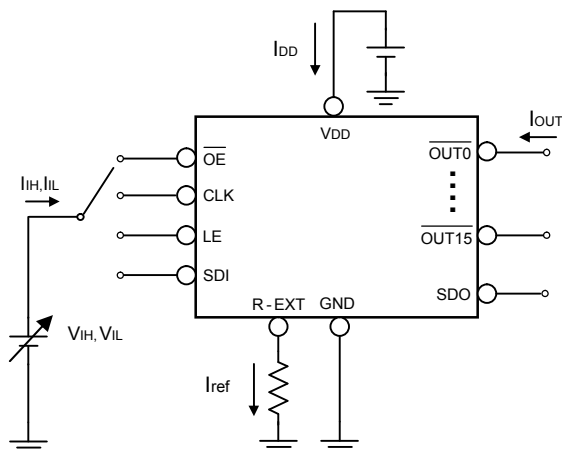

Switching Characteristics

Characteristic		Symbol	Condition	Min.	Typ.	Max.	Unit
Propagation Delay Time ("L" to "H")	CLK - $\overline{\text{OUTn}}$	t_{pLH1}	$V_{DD}=5.0\text{ V}$ $V_{DS}=0.8\text{ V}$ $V_{IH}=V_{DD}$ $V_{IL}=\text{GND}$ $R_{ext}=300\ \Omega$ $V_L=4.0\text{ V}$ $R_L=52\ \Omega$ $C_L=10\text{ pF}$	-	50	100	ns
	LE - $\overline{\text{OUTn}}$	t_{pLH2}		-	50	100	ns
	$\overline{\text{OE}}$ - $\overline{\text{OUTn}}$	t_{pLH3}		-	20	100	ns
	CLK - SDO	t_{pLH}		15	20	-	ns
Propagation Delay Time ("H" to "L")	CLK - $\overline{\text{OUTn}}$	t_{pHL1}		-	100	150	ns
	LE - $\overline{\text{OUTn}}$	t_{pHL2}		-	100	150	ns
	$\overline{\text{OE}}$ - $\overline{\text{OUTn}}$	t_{pHL3}		-	50	150	ns
	CLK - SDO	t_{pHL}		15	20	-	ns
Pulse Width	CLK	$t_w(\text{CLK})$		20	-	-	ns
	LE	$t_w(\text{L})$		20	-	-	ns
	$\overline{\text{OE}}$	$t_w(\text{OE})$		200	-	-	ns
Hold Time for LE		$t_h(\text{L})$		5	-	-	ns
Setup Time for LE		$t_{su}(\text{L})$		5	-	-	ns
Hold Time for SDI		$t_h(\text{D})$		10	-	-	ns
Setup Time for SDI		$t_{su}(\text{D})$		5	-	-	ns
Clock Frequency		F_{CLK}		Cascade Operation		-	-
Maximum CLK Rise Time		t_r^{**}	-	-	-	500	ns
Maximum CLK Fall Time		t_f^{**}	-	-	-	500	ns
Output Rise Time of Vout (turn off)		t_{or}	-	40	120	ns	
Output Fall Time of Vout (turn on)		t_{of}	-	70	200	ns	

**If the devices are connected in cascade and t_r or t_f is large, it may be critical to achieve the timing required for data transfer between two cascaded devices.

Test Circuit for Switching Characteristics

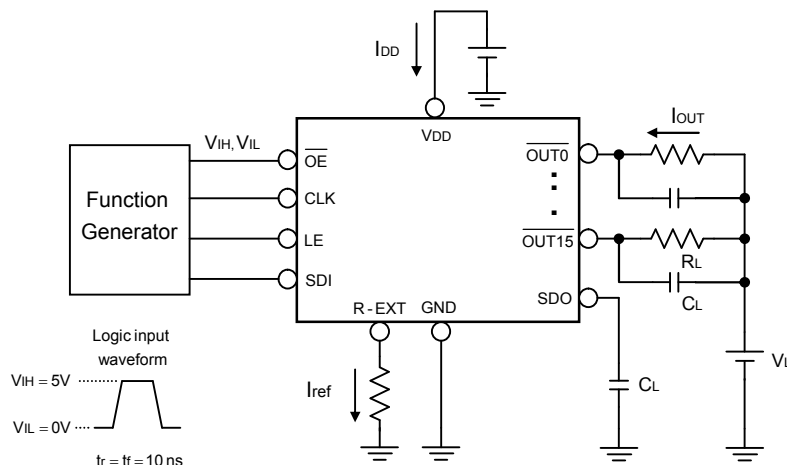

Timing Waveform

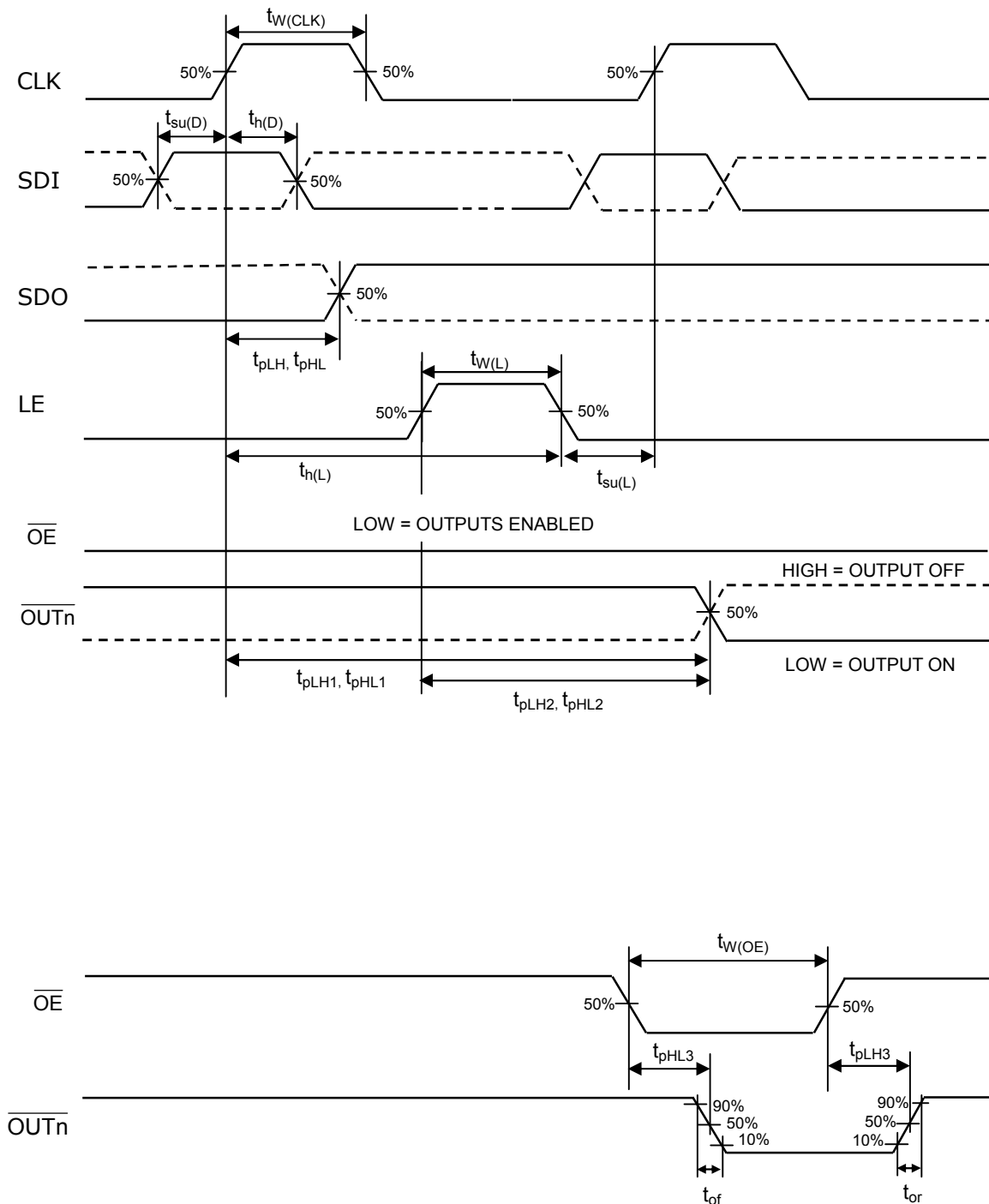

Application Information

Constant Current

In LED display application, MBI5026 provides nearly no variations in current from channel to channel and from IC to IC. This can be achieved by:

- 1) The maximum current variation between channels is less than $\pm 3\%$, and that between ICs is less than $\pm 6\%$.
- 2) In addition, the current characteristic of output stage is flat and users can refer to the figure as shown below. The output current can be kept constant regardless of the variations of LED forward voltages (Vf). This performs as a perfection of load regulation.

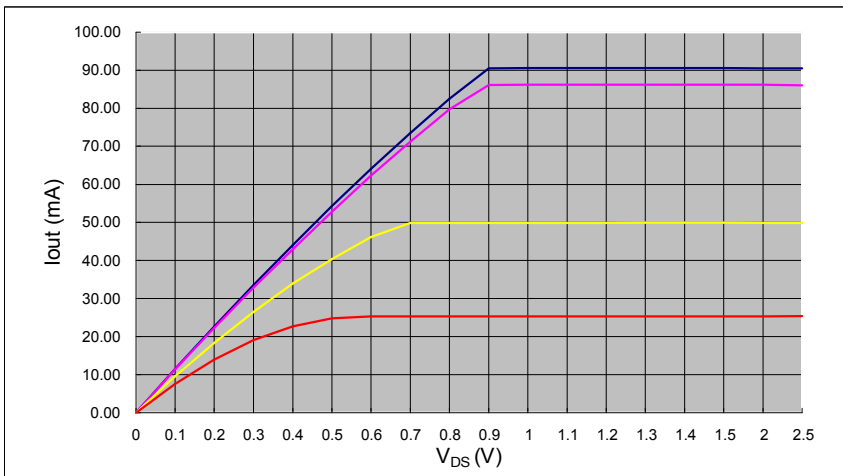

Adjusting Output Current

The output current of each channel (I_{OUT}) is set by an external resistor, R_{ext} . The relationship between I_{out} and R_{ext} is shown in the following figure.

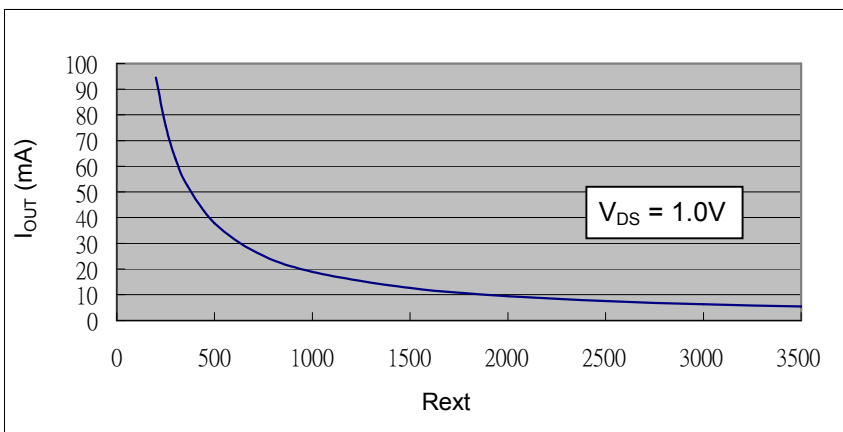

Resistance of the external resistor, R_{ext} , in Ω

Also, the output current can be calculated from the equation:

$$V_{R-EXT} = 1.26V ; I_{OUT} = (V_{R-EXT} / R_{ext}) \times 15$$

where R_{ext} is the resistance of the external resistor connected to R-EXT terminal and V_{R-EXT} is the voltage of R-EXT terminal. The magnitude of current (as a function of R_{ext}) is around 52.5mA at 360 Ω and 26.25mA at 720 Ω .

Package Power Dissipation (P_D)

The maximum allowable package power dissipation is determined as $P_D(max) = (T_J - T_a) / R_{th(j-a)}$. When 16 output channels are turned on simultaneously, the actual package power dissipation is $P_D(act) = (I_{DD} \times V_{DD}) + (I_{OUT} \times Duty \times V_{DS} \times 16)$. Therefore, to keep $P_D(act) \leq P_D(max)$, the allowable maximum output current as a function of duty cycle is:

$$I_{OUT} = \{ [(T_J - T_a) / R_{th(j-a)}] - (I_{DD} \times V_{DD}) \} / V_{DS} / Duty / 16,$$

where $T_J = 150^\circ C$.

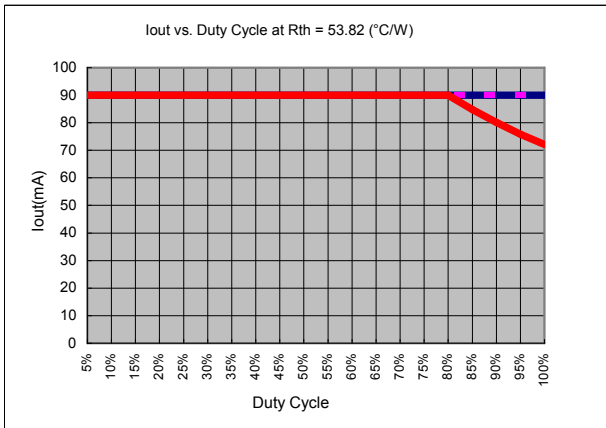

CN type package

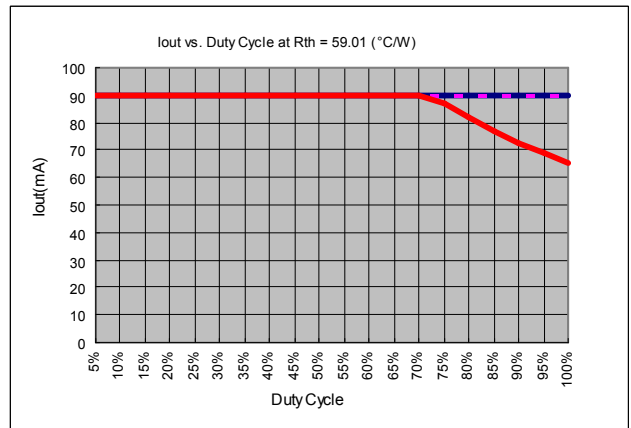

CF type package

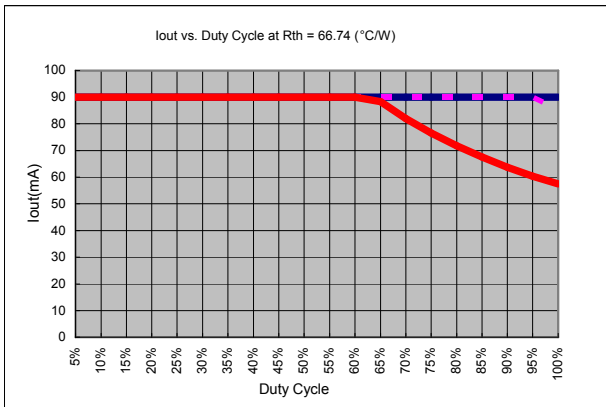

CNS type package

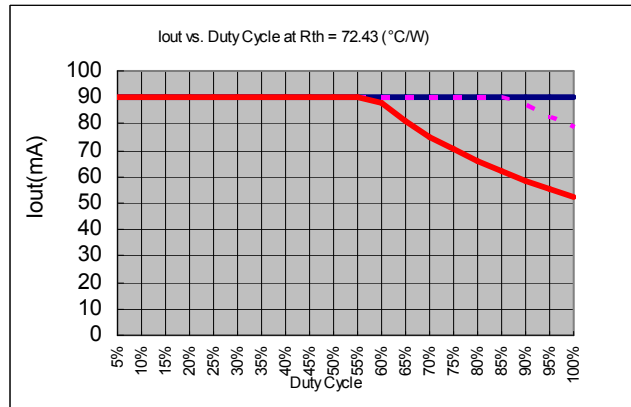

CP\CPA type package

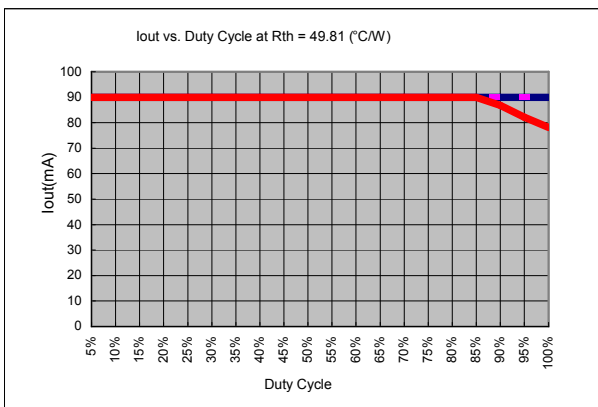

CD type package

Condition : I _{out} = 90mA , V _{DS} = 1.0V , 16 output channels active		
Device Type	R _{th(j-a)} (°C/W)	Note
CN	53.82	
CNS	66.74	
CD	49.81	
CF	59.01	
CP\CPA	72.43	

The maximum power dissipation, $P_D(\max) = (T_j - T_a) / R_{th(j-a)}$, decreases as the ambient temperature increases.

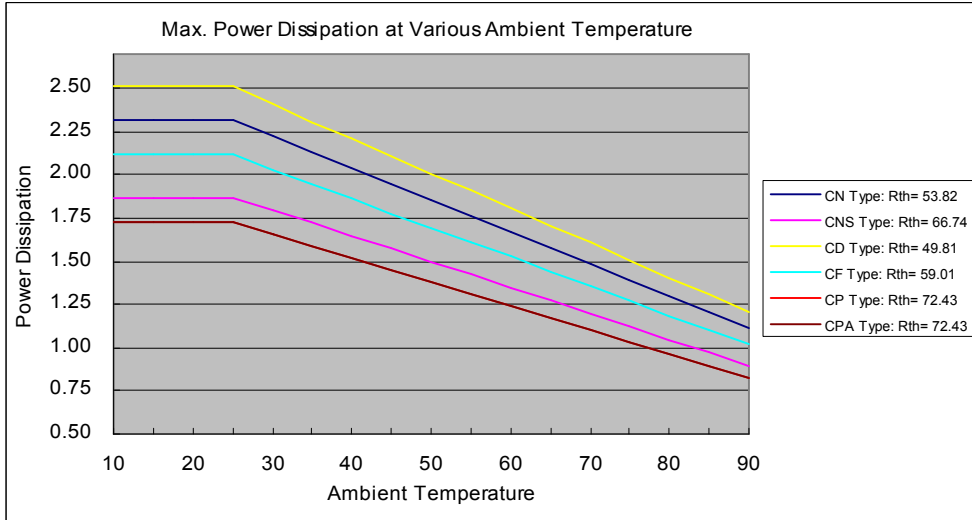

Load Supply Voltage (V_{LED})

MBI5026 are designed to operate with V_{DS} ranging from 0.4V to 1.0V considering the package power dissipating limits. V_{DS} may be higher enough to make $P_{D(act)} > P_{D(max)}$ when $V_{LED} = 5V$ and $V_{DS} = V_{LED} - V_f$, in which V_{LED} is the load supply voltage. In this case, it is recommended to use the lowest possible supply voltage or to set an external voltage reducer, V_{DROP} .

A voltage reducer lets $V_{DS} = (V_{LED} - V_f) - V_{DROP}$.

Resistors or Zener diode can be used in the applications as shown in the following figures.

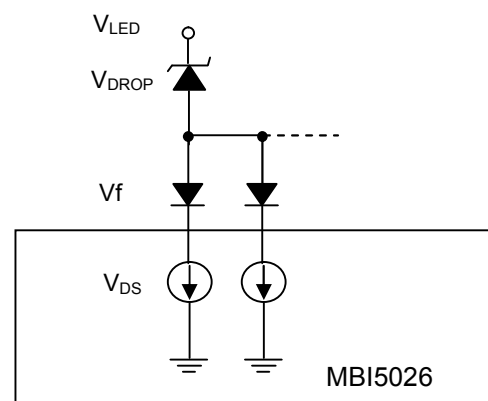
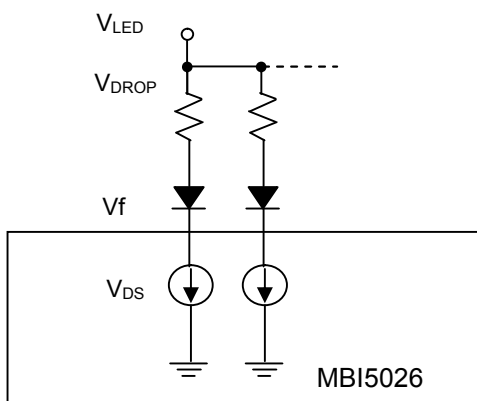

Package Outline

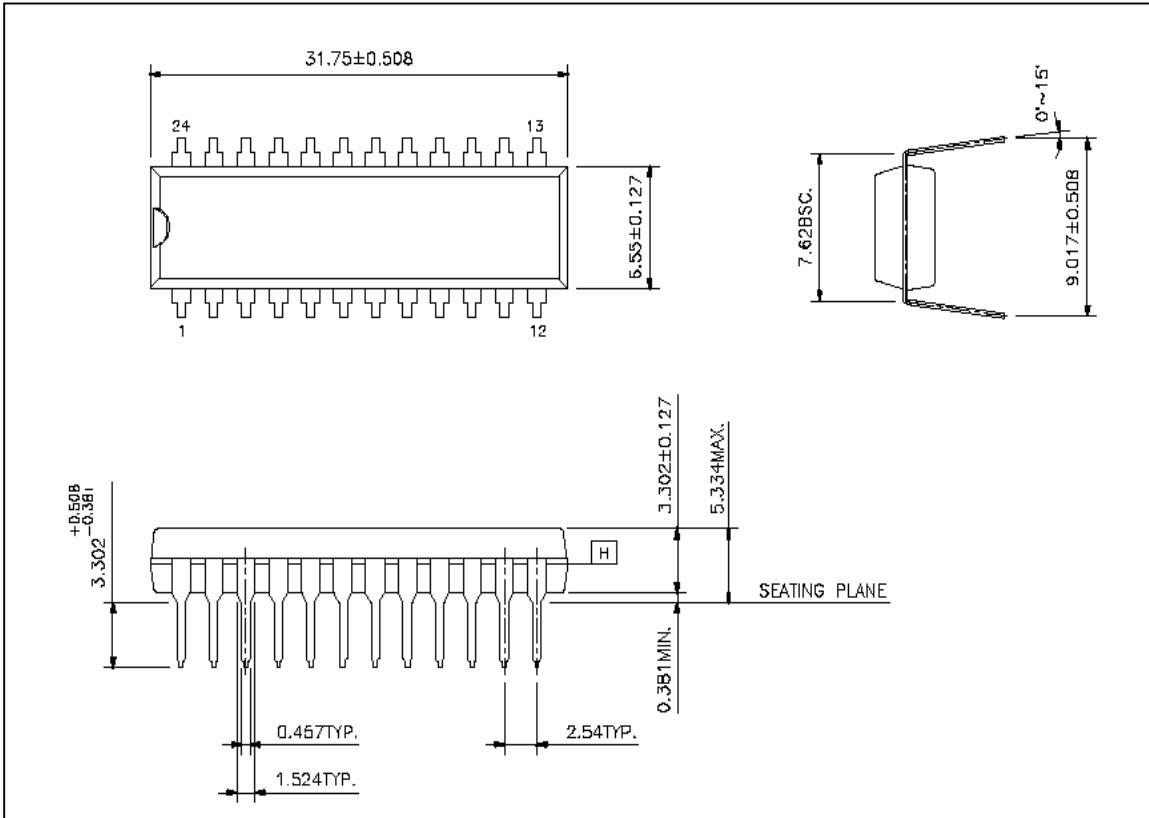

MBI5026CN Outline Drawing

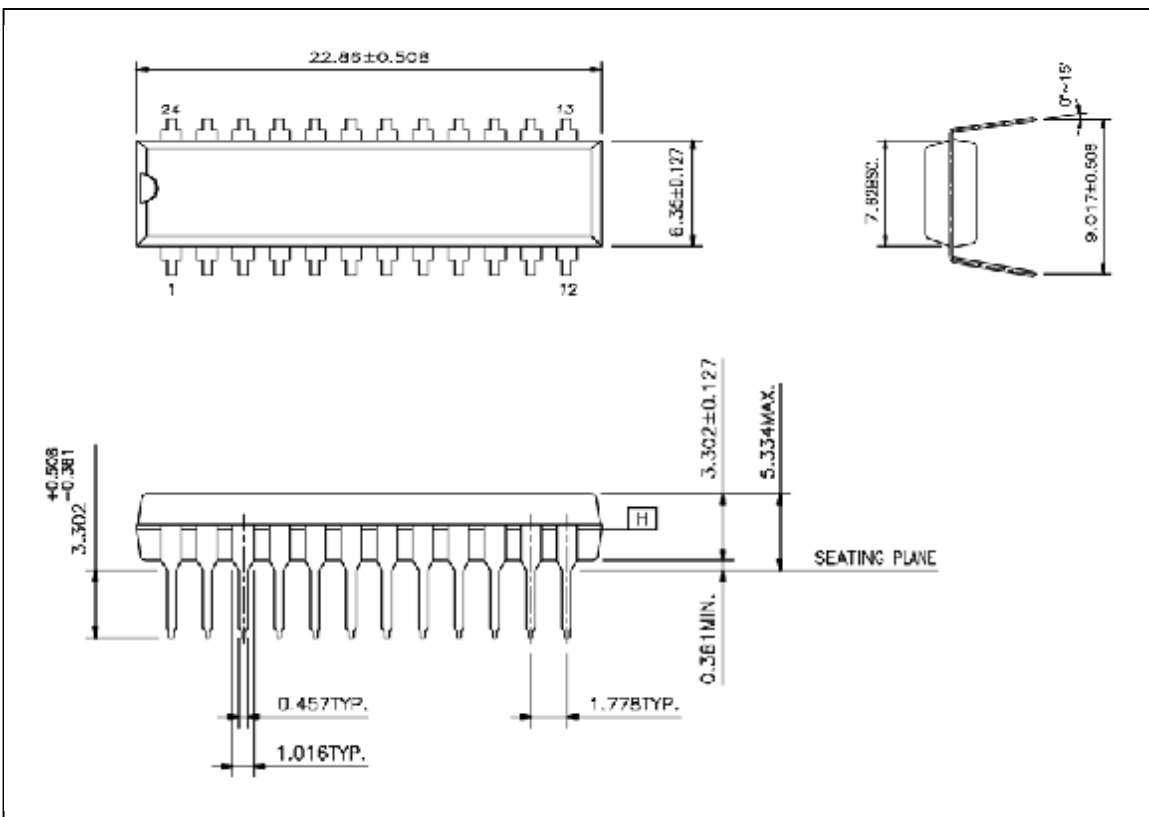

MBI5026CNS Outline Drawing

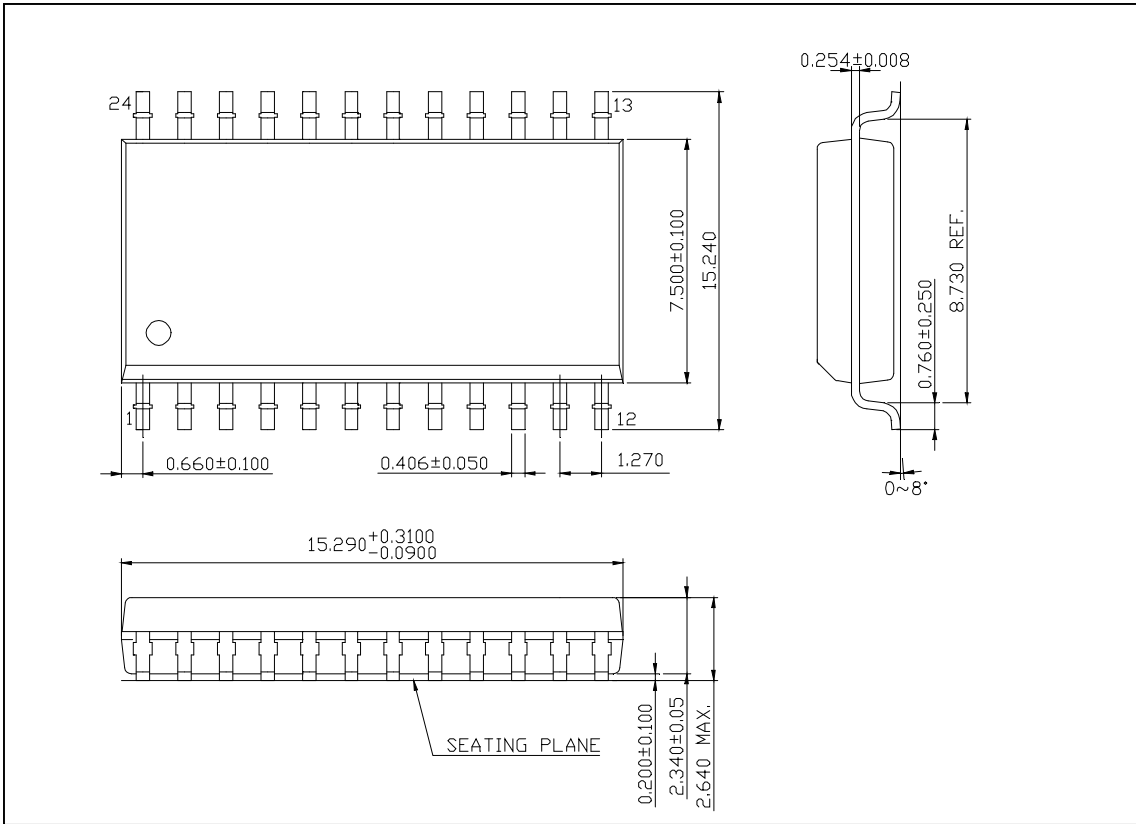

MBI5026CD Outline Drawing

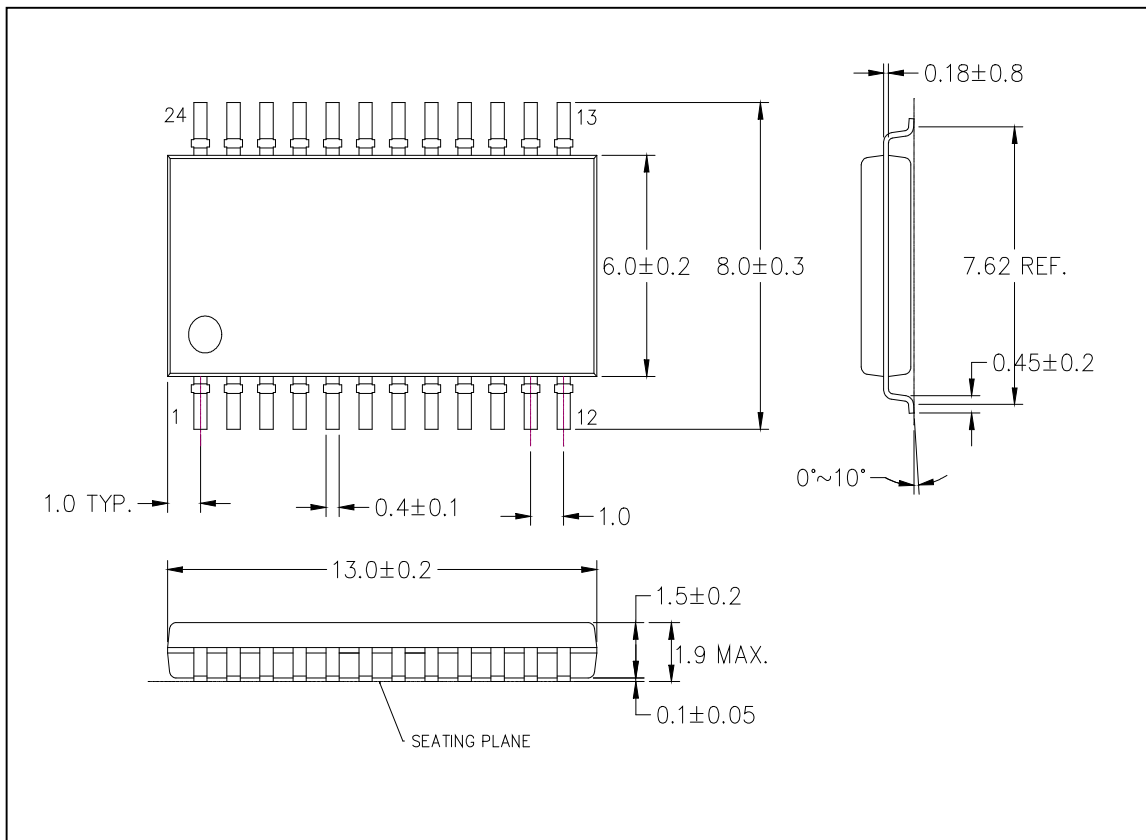

MBI5026CF Outline Drawing

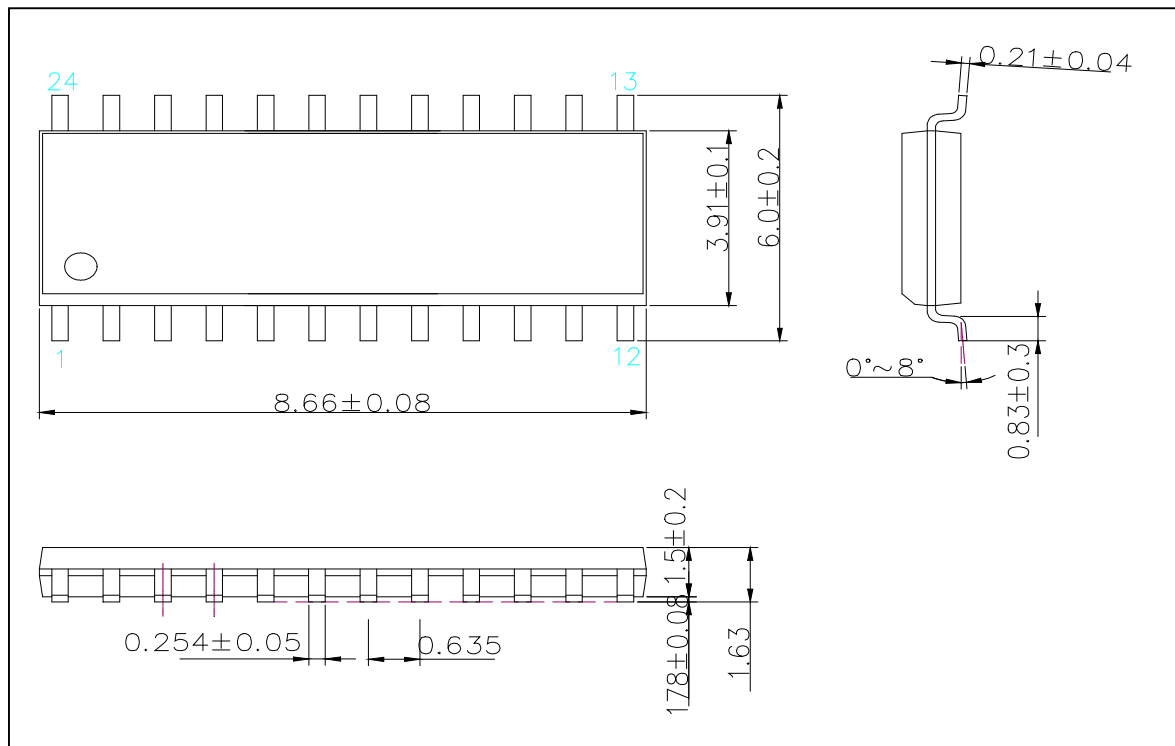

MBI5026CP\CPA Outline Drawing

MBI5026 Package Information

Device Type	Package Type	Weight(g)
CN	P-DIP24-300-2.54	1.628
CNS	SP-DIP24-300-1.78	1.11
CD	SOP24-300-1.27	0.617
CF	SOP24-300-1.00	0.28
CP\CPA	SSOP24-150-0.64	0.11

Note: The unit for the outline drawing is mm.