



MBT2222 MBT2222A

■ MBT222/MBT222A

SILICON PLANAR EPITAXIAL TRANSISTORS

N-P-N TRANSISTORS

■ ABSOLUTE MAXIMUM RATINGS

Descriptions	Symbol	Min.	Typ.	Max.	Unit
Storage Temperature	T _{stg}	-55	-	150	°C
Junction Temperature	T _j	-	-	150	°C
Maximum Power Dissipation (Ta=25°C)	P _{tot}	-	-	250	mW
Maximum Collector to Base Voltage	V _{CB0}	-	-	60/75	V
Maximum Collector to Emitter Voltage	V _{CEO}	-	-	30/40	V
Maximum Emitter to Base Voltage	V _{EBO}	-	-	5.0/6.0	V
Maximum Collector Current	I _C	-	-	600	mA

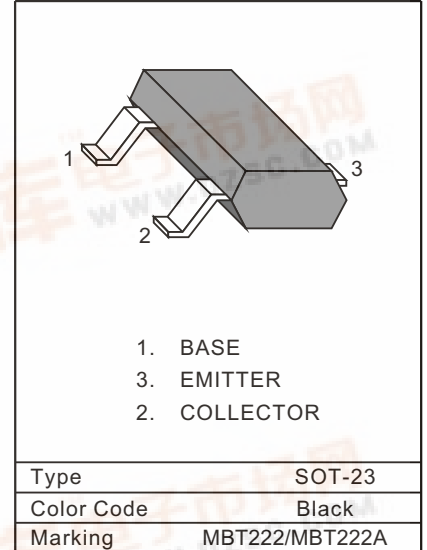

■ ELECTRICAL CHARACTERISTICS (Ta=25°C)

Descriptions	Test Conditions	Symbol	Min.	Typ.	Max.	Unit
DC Current Gain	V _{CE} = 10V, I _C =0.1mA	h _{FE1}	35	-	-	-
	V _{CE} = 10V, I _C =1mA	h _{FE2}	50	-	-	-
	V _{CE} = 10V, I _C =10mA	h _{FE3}	75	-	-	-
	V _{CE} = 10V, I _C =150mA	h _{FE4}	100	-	300	-
	V _{CE} = 1V, I _C =150mA	h _{FE5}	50	-	-	-
	V _{CE} = 10V, I _C =500mA	h _{FE6}	30/40	-	-	-
Gain Bandwidth product	V _{CE} = V, I _C = mA	f _T	250/300	-	-	MHz
Output Capacitance	V _{CB} = V, I _E = mA, f= MHz	C _{ob}	-	-	8.0	pF
Input Capacitance	V _{CE} = V, I _C = mA, f= MHz	C _{ib}	-	-	30/25	pF
(MBT222)	V _{CB} = 50V, I _E = 0mA	I _{CB0}	-	-	0.01	uA
Collector Cut-off Current (MBT222A)	V _{CB} = 60mA, I _E = 0mA	I _{CB0}	-	-	0.01	uA
(MBT222A)	V _{EB} = V, V _{EB} = V	I _{CEx}	-	-	10	nA
Emitter Cut-off Current (MBT222A)	I _C = 0, V _{EB} = 3V	I _{EBO}	-	-	10	nA
Base Current (MBT222A)	V _{EB} = 3V, V _{CE} = 60V	I _{BEx}	-	-	20	nA
Collector Saturation Voltage	I _C = 150mA, I _B = 15mA	V _{CE(Sat)}	-	-	400/300	mV
	I _C = 500mA, I _B = 50mA	V _{CE(Sat)}	-	-	1.6/1.0	V
Base Saturation Voltage	I _C = 150mA, I _B = 15mA,	V _{BE(Sat)}	-	-	1.3/0.6to1.2	V
	I _C = 500mA, I _B = 50mA	V _{BE(Sat)}	-	-	2.6/2.0	V
Collector to Emitter Breakdown Voltage	I _C = 1.0mA, I _C = 0	BV _{CEO}	30/40	-	-	V
	I _C = 100mA, I _B = 0	BV _{CEO}	60/75	-	-	V
Emitter to Base Breakdown Voltage	I _C = 0mA, I _E = 10uA	BV _{EBO}	5.0/6.0	-	-	V
Delay Time	I _C = 150mA	t _d	-	-	10	ns
Rise Time	I _C = 150mA	t _r	-	-	25	ns
Fall Time	I _C = 150mA	t _f	-	-	60	ns
Storage Time	I _C = 150mA	t _{stg}	-	-	225	ns
Small Signal Current Gain	V _{CE} = 10V, I _C = 1.0mA, f=1kHz	h _{FE}	50	-	300	-
	V _{CE} = 10mA, I _C = 10mA, f=1kHz	h _{FE}	75	-	375	-

Pulse Test ≤ 300μS, Duty Cycle ≤ 2%

■ THERMAL CHARACTERISTICS

Descriptions	Symbol	Min.	Typ.	Max.	Unit
Thermal Resistance at T _j = P(R _{th j-t} + R _{th t-s} + R _{th s-a}) + T _{amb}	R _{th j-a}	-	500	-	K/W

P / N	MBT222	MBT222A
marking	1B	1P

