

8-Bit Shift Register

The MC10E/100E141 is an 8-bit full-function shift register. The E141 performs serial/parallel in and serial/parallel out, shifting in either direction. The eight inputs D₀ – D₇ accept parallel input data, while DL/DR accept serial input data for left/right shifting. The Q_n outputs do not need to be terminated for the shift operation to function. To minimize noise and power, any Q output not used should be left unterminated.

- 700MHz Min. Shift Frequency
- 8-Bit
- Full-Function, Bi-Directional
- Asynchronous Master Reset
- Pin-Compatible with E241
- Extended 100E V_{EE} Range of – 4.2V to – 5.46V
- 75kΩ Input Pulldown Resistors

The select pins, SEL0 and SEL1, select one of four modes of operation: Load, Hold, Shift Left, Shift Right, according to the Function Table.

Input data is accepted a set-up time before the positive clock edge. A HIGH on the Master Reset (MR) pin asynchronously resets all the registers to zero.

Pinout: 28-Lead PLCC (Top View)

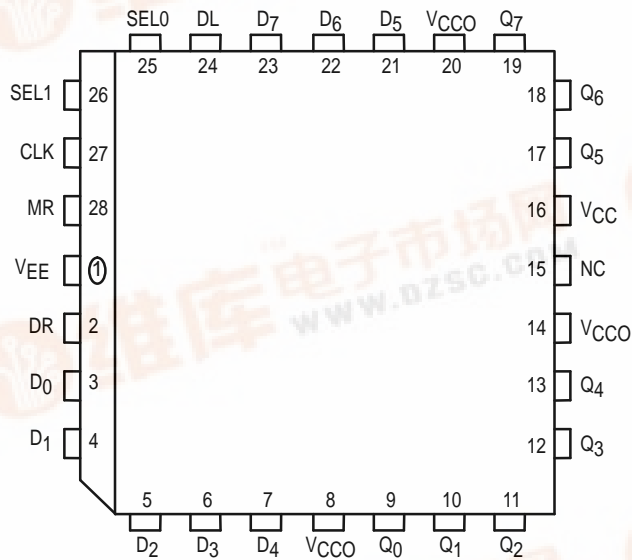

* All V_{CC} and V_{CCO} pins are tied together on the die.

MC10E141
MC100E141

8-BIT SHIFT REGISTER

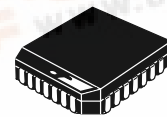

FN SUFFIX
PLASTIC PACKAGE
CASE 776-02

FUNCTION TABLE

SEL0	SEL1	Function
L	L	Load
L	H	Shift Right (D _n to D _{n+1})
H	L	Shift Left (D _n to D _{n-1})
H	H	Hold

PIN NAMES

Pin	Function
D ₀ – D ₇	Parallel Data Inputs
DL, DR	Serial Data Inputs
SEL0, SEL1	Mode Select In Inputs
CLK	Clock
Q ₀ – Q ₇	Data Outputs
MR	Master Reset

EXPANDED FUNCTION TABLE

Function	DL	DR	SEL0	SEL1	MR	CLK	Q0	Q1	Q2	Q3	Q4	Q5	Q6	Q7
Load	X	X	L	L	L	Z	D0	D1	D2	D3	D4	D5	D6	D7
Shift Right	X	L	L	H	L	Z	L	Q0	Q1	Q2	Q3	Q4	Q5	Q6
Shift Left	X	H	L	H	L	Z	H	L	Q0	Q1	Q2	Q3	Q4	Q5
Hold	L	X	H	L	L	Z	L	Q0	Q1	Q2	Q3	Q4	Q5	L
Hold	H	X	H	L	L	Z	Q0	Q1	Q2	Q3	Q4	Q5	L	H
Reset	X	X	H	H	L	Z	Q0	Q1	Q2	Q3	Q4	Q5	L	H
Reset	X	X	X	X	H	X	L	L	L	L	L	L	L	L



MC10E141 MC100E141

LOGIC DIAGRAM

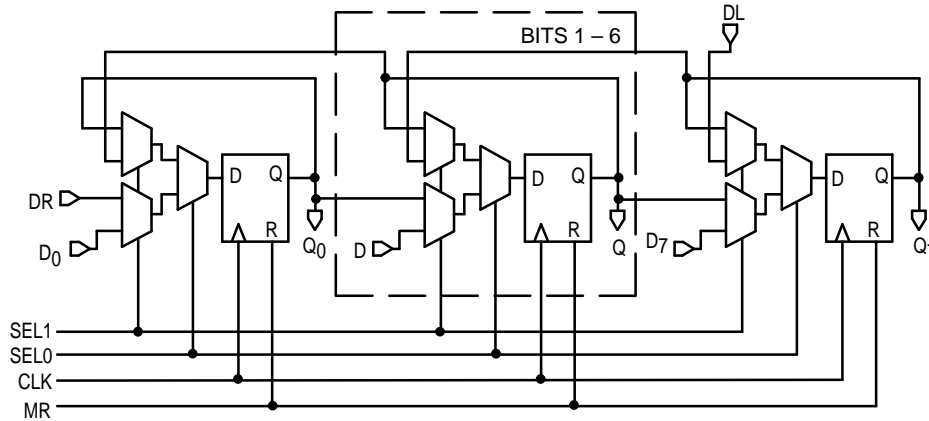

DC CHARACTERISTICS (V_{EE} = V_{EE}(min) to V_{EE}(max); V_{CC} = V_{CCO} = GND)

Symbol	Characteristic	0°C			25°C			85°C			Unit	Condition
		min	typ	max	min	typ	max	min	typ	max		
I _{IH}	Input HIGH Current			150			150			150	μA	
I _{EE}	Power Supply Current										mA	
	10E		131	181		131	181		131	181		
	100E		131	181		131	181		151	181		

AC CHARACTERISTICS (V_{EE} = V_{EE}(min) to V_{EE}(max); V_{CC} = V_{CCO} = GND)

Symbol	Characteristic	0°C			25°C			85°C			Unit	Condition
		min	typ	max	min	typ	max	min	typ	max		
f _{SHIFT}	Max. Shift Frequency	700	900		700	900		700	900		MHz	
t _{PLH} t _{PHL}	Propagation Delay To Output Clk MR	625 600	750 725	975 975	625 600	750 725	975 975	625 600	750 725	975 975	ps	
t _s	Setup Time D SEL0 SEL1	175 350 300	25 200 150		175 350 300	25 200 150		175 350 300	25 200 150		ps	
t _h	Hold Time D SEL0 SEL1	200 100 100	-25 -200 -150		200 100 100	-25 -200 -150		200 100 100	-25 -200 -150		ps	
t _{RR}	Reset Recovery Time	900	700		900	700		900	700		ps	
t _{PW}	Minimum Pulse Width Clk, MR	400			400			400			ps	
t _{SKEW}	Within-Device Skew		60			60			60		ps	1
t _r t _f	Rise/Fall Times 20 - 80%	300	525	800	300	525	800	300	525	800	ps	

1. Within-device skew is defined as identical transitions on similar paths through a device.

OUTLINE DIMENSIONS

FN SUFFIX
 PLASTIC PLCC PACKAGE
 CASE 776-02
 ISSUE D

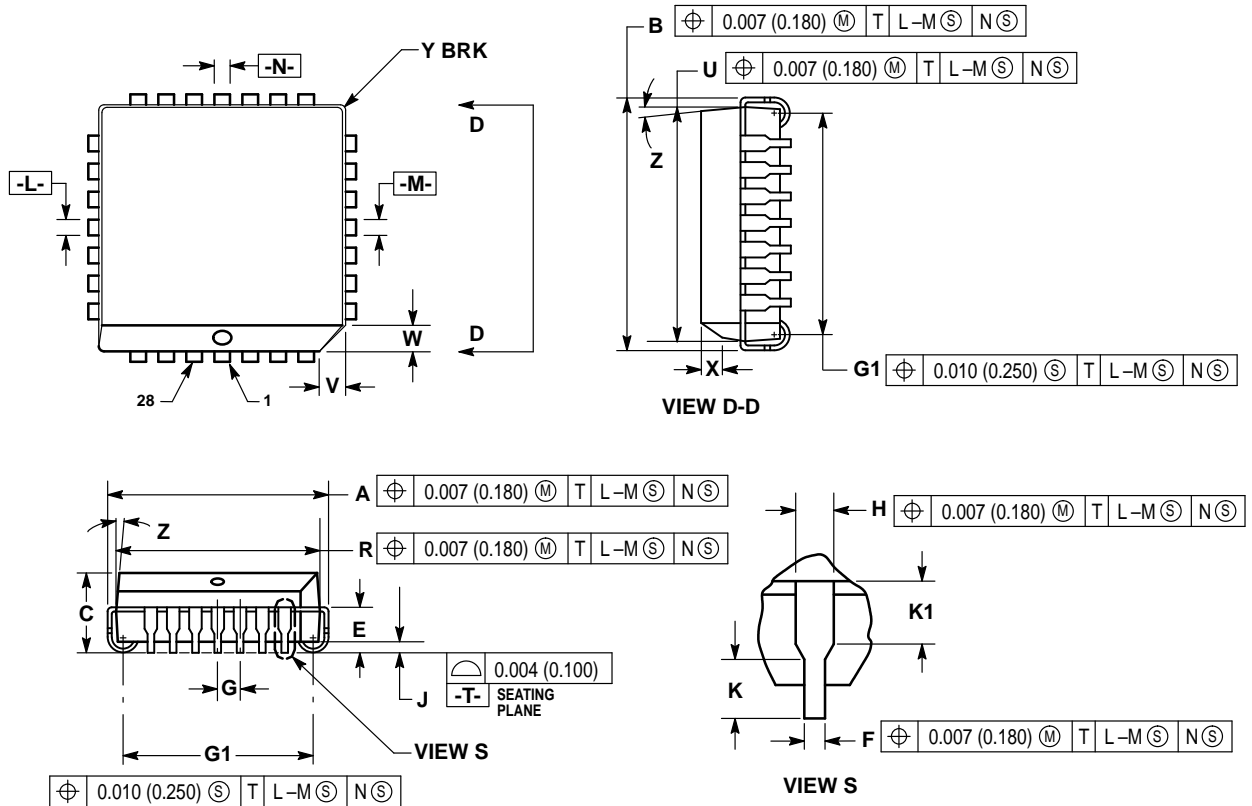

NOTES:

- DATUMS -L-, -M-, AND -N- DETERMINED WHERE TOP OF LEAD SHOULDER EXITS PLASTIC BODY AT MOLD PARTING LINE.
- DIM G1, TRUE POSITION TO BE MEASURED AT DATUM -T-, SEATING PLANE.
- DIM R AND U DO NOT INCLUDE MOLD FLASH. ALLOWABLE MOLD FLASH IS 0.010 (0.250) PER SIDE.
- DIMENSIONING AND TOLERANCING PER ANSI Y14.5M, 1982.
- CONTROLLING DIMENSION: INCH.
- THE PACKAGE TOP MAY BE SMALLER THAN THE PACKAGE BOTTOM BY UP TO 0.012 (0.300). DIMENSIONS R AND U ARE DETERMINED AT THE OUTERMOST EXTREMES OF THE PLASTIC BODY EXCLUSIVE OF MOLD FLASH, TIE BAR BURRS, GATE BURRS AND INTERLEAD FLASH, BUT INCLUDING ANY MISMATCH BETWEEN THE TOP AND BOTTOM OF THE PLASTIC BODY.
- DIMENSION H DOES NOT INCLUDE DAMBAR PROTRUSION OR INTRUSION. THE DAMBAR PROTRUSION(S) SHALL NOT CAUSE THE H DIMENSION TO BE GREATER THAN 0.037 (0.940). THE DAMBAR INTRUSION(S) SHALL NOT CAUSE THE H DIMENSION TO BE SMALLER THAN 0.025 (0.635).

DIM	INCHES		MILLIMETERS	
	MIN	MAX	MIN	MAX
A	0.485	0.495	12.32	12.57
B	0.485	0.495	12.32	12.57
C	0.165	0.180	4.20	4.57
E	0.090	0.110	2.29	2.79
F	0.013	0.019	0.33	0.48
G	0.050 BSC		1.27 BSC	
H	0.026	0.032	0.66	0.81
J	0.020	—	0.51	—
K	0.025	—	0.64	—
R	0.450	0.456	11.43	11.58
U	0.450	0.456	11.43	11.58
V	0.042	0.048	1.07	1.21
W	0.042	0.048	1.07	1.21
X	0.042	0.056	1.07	1.42
Y	—	0.020	—	0.50
Z	2°	10°	2°	10°
G1	0.410	0.430	10.42	10.92
K1	0.040	—	1.02	—

MC10E141 MC100E141

Motorola reserves the right to make changes without further notice to any products herein. Motorola makes no warranty, representation or guarantee regarding the suitability of its products for any particular purpose, nor does Motorola assume any liability arising out of the application or use of any product or circuit, and specifically disclaims any and all liability, including without limitation consequential or incidental damages. "Typical" parameters which may be provided in Motorola data sheets and/or specifications can and do vary in different applications and actual performance may vary over time. All operating parameters, including "Typicals" must be validated for each customer application by customer's technical experts. Motorola does not convey any license under its patent rights nor the rights of others. Motorola products are not designed, intended, or authorized for use as components in systems intended for surgical implant into the body, or other applications intended to support or sustain life, or for any other application in which the failure of the Motorola product could create a situation where personal injury or death may occur. Should Buyer purchase or use Motorola products for any such unintended or unauthorized application, Buyer shall indemnify and hold Motorola and its officers, employees, subsidiaries, affiliates, and distributors harmless against all claims, costs, damages, and expenses, and reasonable attorney fees arising out of, directly or indirectly, any claim of personal injury or death associated with such unintended or unauthorized use, even if such claim alleges that Motorola was negligent regarding the design or manufacture of the part. Motorola and  are registered trademarks of Motorola, Inc. Motorola, Inc. is an Equal Opportunity/Affirmative Action Employer.

How to reach us:

USA/EUROPE/Locations Not Listed: Motorola Literature Distribution;
P.O. Box 20912; Phoenix, Arizona 85036. 1-800-441-2447 or 602-303-5454

MFAX: RMFAX0@email.sps.mot.com – TOUCHTONE 602-244-6609
INTERNET: <http://Design-NET.com>

JAPAN: Nippon Motorola Ltd.; Tatsumi-SPD-JLDC, 6F Seibu-Butsuryu-Center,
3-14-2 Tatsumi Koto-Ku, Tokyo 135, Japan. 03-81-3521-8315

ASIA/PACIFIC: Motorola Semiconductors H.K. Ltd.; 8B Tai Ping Industrial Park,
51 Ting Kok Road, Tai Po, N.T., Hong Kong. 852-26629298