

Programmable Delay Chip

The MC10E100E196 is a programmable delay chip (PDC) designed primarily for very accurate differential ECL input edge placement applications.

The delay section consists of a chain of gates and a linear ramp delay adjust organized as shown in the logic symbol. The first two delay elements feature gates that have been modified to have delays 1.25 and 1.5 times the basic gate delay of approximately 80 ps. These two elements provide the E196 with a digitally-selectable resolution of approximately 20 ps. The required device delay is selected by the seven address inputs D[0:6], which are latched on chip by a high signal on the latch enable (LEN) control.

The FTUNE input takes an analog voltage and applies it to an internal linear ramp for reducing the 20 ps resolution still further. The FTUNE input is what differentiates the E196 from the E195.

An eighth latched input, D7, is provided for cascading multiple PDC's for increased programmable range. The cascade logic allows full control of multiple PDC's, at the expense of only a single added line to the data bus for each additional PDC, without the need for any external gating.

- 2.0ns Worst Case Delay Range
- ≈20ps/Delay Step Resolution
- Linear Input for Tighter Resolution
- >1.0GHz Bandwidth
- On Chip Cascade Circuitry
- Extended 100E V_{EE} Range of -4.2 to -5.46V
- 75KΩ Input Pulldown Resistors

PIN NAMES

Pin	Function
IN/IN	Signal Input
EN	Input Enable
D[0:7]	Mux Select Inputs
Q/Q	Signal Output
LEN	Latch Enable
SET MIN	Min Delay Set
SET MAX	Max Delay Set
CASCADE	Cascade Signal
FTUNE	Linear Voltage Input

MC10E196
MC100E196

PROGRAMMABLE
DELAY CHIP

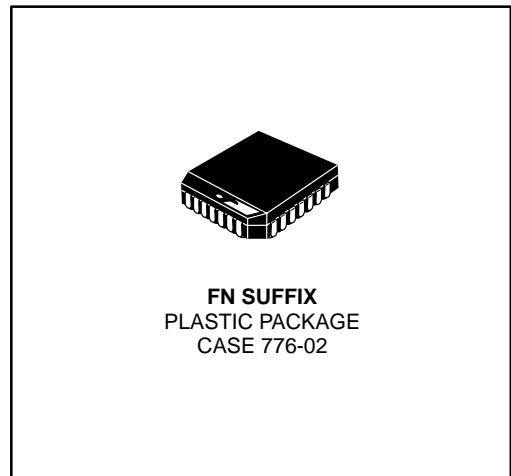

LOGIC DIAGRAM – SIMPLIFIED

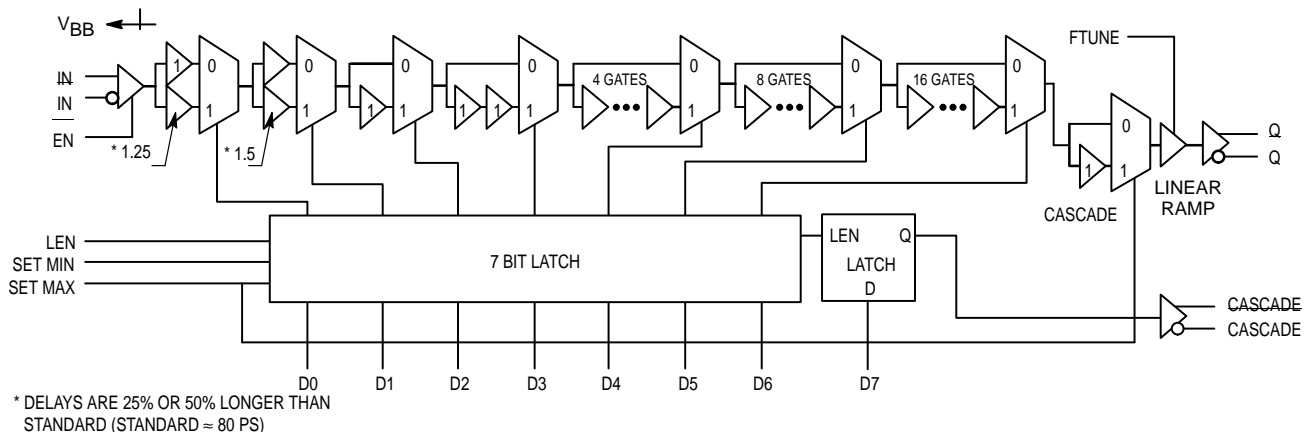

Pinout: 28-Lead PLCC (Top View)

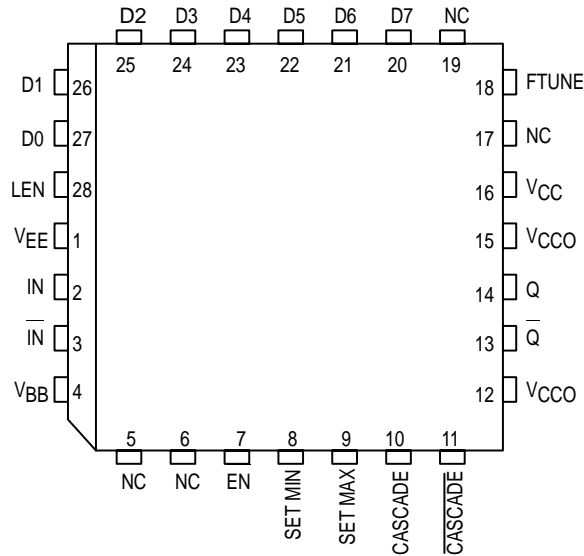

DC CHARACTERISTICS ($V_{EE} = V_{EE}(\text{min})$ to $V_{EE}(\text{max})$; $V_{CC} = V_{CCO} = \text{GND}$)

Symbol	Characteristic	0°C			25°C			85°C			Unit	Condition
		Min	Typ	Max	Min	Typ	Max	Min	Typ	Max		
I_{IH}	Input HIGH Current			150			150			150	μA	
I_{EE}	Power Supply Current										mA	
	10E		130	156		130	156		130	156		
	100E		130	156		130	156		150	179		

AC CHARACTERISTICS ($V_{EE} = V_{EE}(\text{min})$ to $V_{EE}(\text{max})$; $V_{CC} = V_{CCO} = \text{GND}$)

Symbol	Characteristic	0°C			25°C			85°C			Unit	Notes
		Min	Typ	Max	Min	Typ	Max	Min	Typ	Max		
t_{PLH} t_{PHL}	Propagation Delay IN to Q; Tap = 0 IN to Q; Tap = 127 EN to Q; Tap = 0 D7 to CASCADE	1210 3320 1250 300	1360 3570 1450 450	1510 3820 1650 700	1240 3380 1275 300	1390 3630 1475 450	1540 3880 1675 700	1440 3920 1350 300	1590 4270 1650 450	1765 4720 1950 700	ps	
t_{RANGE}	Programmable Range $t_{PD}(\text{max}) - t_{PD}(\text{min})$	2000	2175		2050	2240		2375	2580		ps	
Δt	Step Delay D0 High D1 High D2 High D3 High D4 High D5 High D6 High		17 34 55 115 250 505 1000			17.5 35 70 140 280 560 1120			21 42 84 168 336 672 1344		ps	6
Lin	Linearity	D1	D0		D1	D0		D1	D0			7
t_{SKEW}	Duty Cycle Skew $t_{PHL} - t_{PLH}$		± 30			± 30			± 30		ps	1

AC CHARACTERISTICS (continued) ($V_{EE} = V_{EE}(\text{min})$ to $V_{EE}(\text{max})$; $V_{CC} = V_{CCO} = \text{GND}$)

Symbol	Characteristic	0°C			25°C			85°C			Unit	Notes
		Min	Typ	Max	Min	Typ	Max	Min	Typ	Max		
t_s	D to LEN	200	0		200	0		200	0		ps	2 3
	D to IN	800			800			800				
	EN to IN	200			200			200				
t_h	LEN to D	500	250		500	250		500	250		ps	4
	IN to EN	0			0			0				
t_R	EN to IN	300			300			300			ps	5
	SET MAX to LEN	800			800			800				
	SET MIN to LEN	800			800			800				
t_{jit}	Jitter		<5.0			<5.0			<5.0		ps	8
t_r t_f	Output Rise/Fall Time 20–80% (Q)	125	225	325	125	225	325	125	225	325	ps	
	20–80% (CASCADE)	300	450	650	300	450	650	300	450	650		

1. Duty cycle skew guaranteed only for differential operation measured from the cross point of the input to the cross point of the output.
2. This setup time defines the amount of time prior to the input signal the delay tap of the device must be set.
3. This setup time is the minimum time that EN must be asserted prior to the next transition of IN/IN to prevent an output response greater than ± 75 mV to that IN/IN transition.
4. This hold time is the minimum time that EN must remain asserted after a negative going IN or positive going IN to prevent an output response greater than ± 75 mV to that IN/IN transition.
5. This release time is the minimum time that EN must be deasserted prior to the next IN/IN transition to ensure an output response that meets the specified IN to Q propagation delay and transition times.
6. Specification limits represent the amount of delay added with the assertion of each individual delay control pin. The various combinations of asserted delay control inputs will typically realize D0 resolution steps across the specified programmable range.
7. The linearity specification guarantees to which delay control input the programmable steps will be monotonic (i.e. increasing delay steps for increasing binary counts on the control inputs Dn). Typically the device will be monotonic to the D0 input, however under worst case conditions and process variation, delays could decrease slightly with increasing binary counts when the D0 input is the LSB. With the D1 input as the LSB the device is guaranteed to be monotonic over all specified environmental conditions and process variation.
8. The jitter of the device is less than what can be measured without resorting to very tedious and specialized measurement techniques.

ANALOG INPUT CHARACTERISTICS

$F_{tune} = V_{CC}$ to V_{EE}

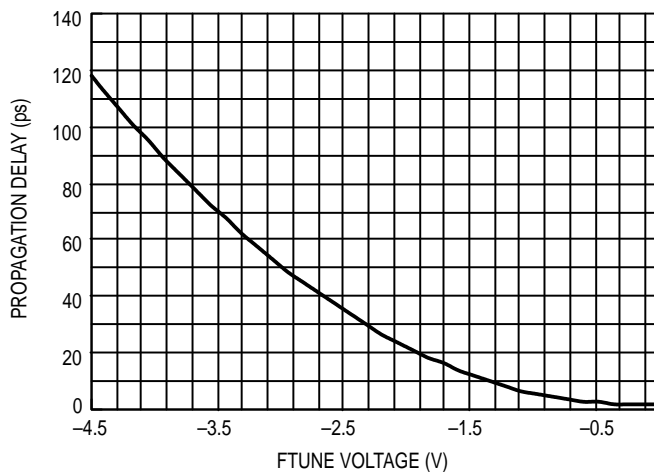

**Propagation Delay versus Ftune Voltage
(100E196)**

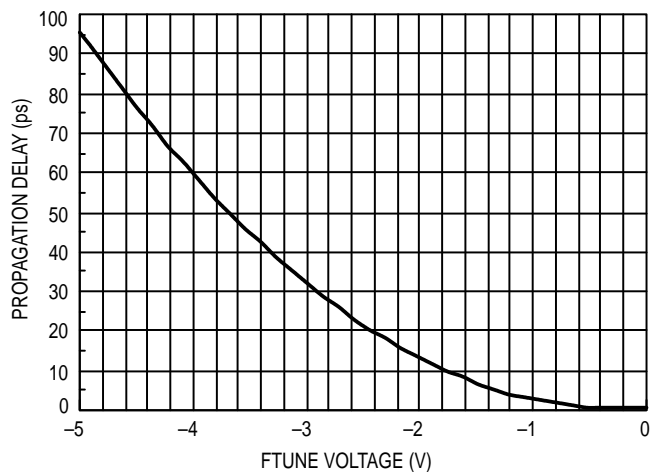

**Propagation Delay versus Ftune Voltage
(10E196)**

USING THE FTUNE ANALOG INPUT

The analog FTUNE pin on the E196 device is intended to enhance the 20 ps resolution capabilities of the fully digital E195. The level of resolution obtained is dependent on the number of increments applied to the appropriate range on the FTUNE pin.

To provide another level of resolution the FTUNE pin must be capable of adjusting the delay by greater than the 20 ps digital resolution. From the provided graphs one sees that this requirement is easily achieved as over the entire FTUNE voltage range a 100 ps delay can be achieved. This extra analog range ensures that the FTUNE pin will be capable even under worst case conditions of covering the digital resolution. Typically the analog input will be driven by an external DAC to provide a digital control with very fine analog output steps. The final resolution of the device will be dependent on the width of the DAC chosen.

To determine the voltage range necessary for the FTUNE input, the graphs provided should be used. As an example if a range of 40 ps is selected to cover worst case conditions and ensure coverage of the digital range, from the 100E196 graph a voltage range of -3.25 V to -4.0 V would be necessary on the FTUNE pin. Obviously there are numerous voltage ranges which can be used to cover a given delay range, users are given the flexibility to determine which one best fits their designs.

Cascading Multiple E196's

To increase the programmable range of the E195 internal cascade circuitry has been included. This circuitry allows for the cascading of multiple E195's without the need for any external gating. Furthermore this capability requires only one more address line per added E195. Obviously cascading multiple PDC's will result in a larger programmable range, however, this increase is at the expense of a longer minimum delay.

Figure 1 illustrates the interconnect scheme for cascading two E195's. As can be seen, this scheme can easily be

expanded for larger E195 chains. The D7 input of the E195 is the cascade control pin. With the interconnect scheme of Figure 1 when D7 is asserted it signals the need for a larger programmable range than is achievable with a single device.

An expansion of the latch section of the block diagram is pictured below. Use of this diagram will simplify the explanation of how the cascade circuitry works. When D7 of chip #1 above is low the cascade output will also be low while the cascade bar output will be a logical high. In this condition the SET MIN pin of chip #2 will be asserted and thus all of the latches of chip #2 will be reset and the device will be set at its minimum delay. Since the RESET and SET inputs of the latches are overriding any changes on the A0-A6 address bus will not affect the operation of chip #2.

Chip #1 on the other hand will have both SET MIN and SET MAX de-asserted so that its delay will be controlled entirely by the address bus A0-A6. If the delay needed is greater than can be achieved with 31.75 gate delays (1111111 on the A0-A6 address bus) D7 will be asserted to signal the need to cascade the delay to the next E195 device. When D7 is asserted the SET MIN pin of chip #2 will be de-asserted and the delay will be controlled by the A0-A6 address bus. Chip #1 on the other hand will have its SET MAX pin asserted resulting in the device delay to be independent of the A0-A6 address bus.

When the SET MAX pin of chip #1 is asserted the D0 and D1 latches will be reset while the rest of the latches will be set. In addition, to maintain monotonicity an additional gate delay is selected in the cascade circuitry. As a result when D7 of chip #1 is asserted the delay increases from 31.75 gates to 32 gates. A 32 gate delay is the maximum delay setting for the E195.

When cascading multiple PDC's it will prove more cost effective to use a single E196 for the MSB of the chain while using E195 for the lower order bits. This is due to the fact that only one fine tune input is needed to further reduce the delay step resolution.

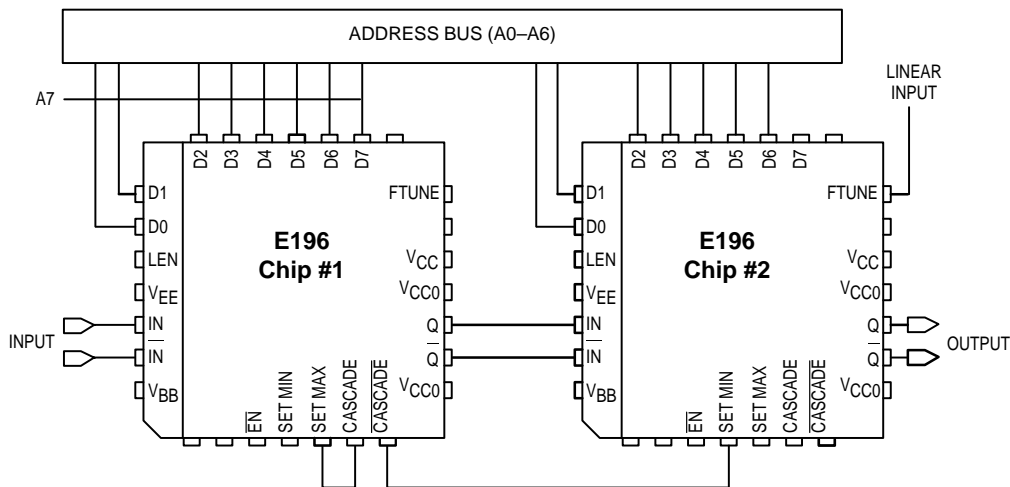

Figure 1. Cascading Interconnect Architecture

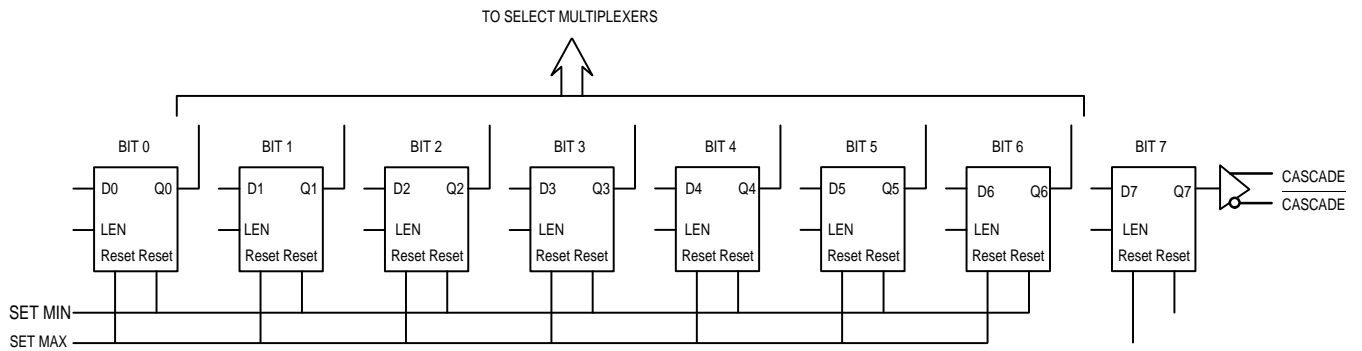
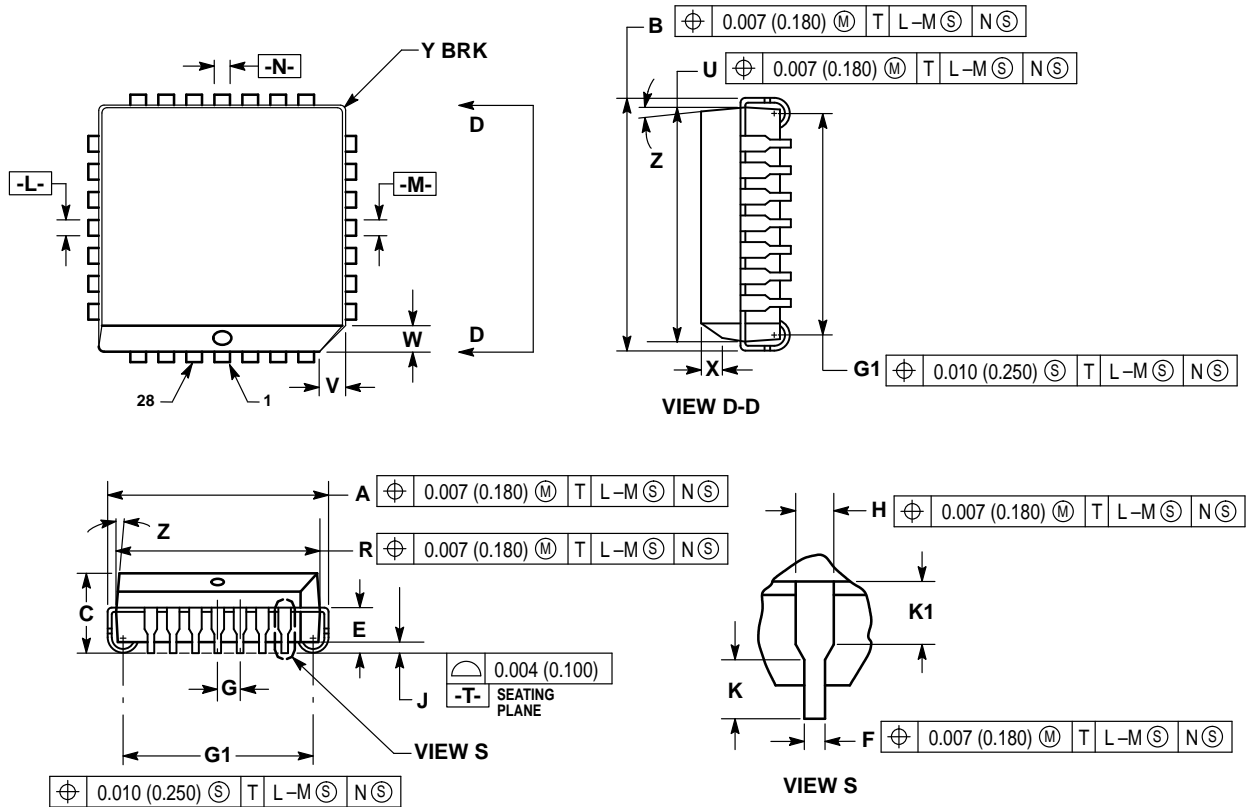

Figure 2. Expansion of the Latch Section of the E195 Block Diagram

OUTLINE DIMENSIONS

FN SUFFIX
 PLASTIC PLCC PACKAGE
 CASE 776-02
 ISSUE D



NOTES:

- DATUMS -L-, -M-, AND -N- DETERMINED WHERE TOP OF LEAD SHOULDER EXITS PLASTIC BODY AT MOLD PARTING LINE.
- DIM G1, TRUE POSITION TO BE MEASURED AT DATUM -T-, SEATING PLANE.
- DIM R AND U DO NOT INCLUDE MOLD FLASH. ALLOWABLE MOLD FLASH IS 0.010 (0.250) PER SIDE.
- DIMENSIONING AND TOLERANCING PER ANSI Y14.5M, 1982.
- CONTROLLING DIMENSION: INCH.
- THE PACKAGE TOP MAY BE SMALLER THAN THE PACKAGE BOTTOM BY UP TO 0.012 (0.300). DIMENSIONS R AND U ARE DETERMINED AT THE OUTERMOST EXTREMES OF THE PLASTIC BODY EXCLUSIVE OF MOLD FLASH, TIE BAR BURRS, GATE BURRS AND INTERLEAD FLASH, BUT INCLUDING ANY MISMATCH BETWEEN THE TOP AND BOTTOM OF THE PLASTIC BODY.
- DIMENSION H DOES NOT INCLUDE DAMBAR PROTRUSION OR INTRUSION. THE DAMBAR PROTRUSION(S) SHALL NOT CAUSE THE H DIMENSION TO BE GREATER THAN 0.037 (0.940). THE DAMBAR INTRUSION(S) SHALL NOT CAUSE THE H DIMENSION TO BE SMALLER THAN 0.025 (0.635).

DIM	INCHES		MILLIMETERS	
	MIN	MAX	MIN	MAX
A	0.485	0.495	12.32	12.57
B	0.485	0.495	12.32	12.57
C	0.165	0.180	4.20	4.57
E	0.090	0.110	2.29	2.79
F	0.013	0.019	0.33	0.48
G	0.050 BSC		1.27 BSC	
H	0.026	0.032	0.66	0.81
J	0.020	—	0.51	—
K	0.025	—	0.64	—
R	0.450	0.456	11.43	11.58
U	0.450	0.456	11.43	11.58
V	0.042	0.048	1.07	1.21
W	0.042	0.048	1.07	1.21
X	0.042	0.056	1.07	1.42
Y	—	0.020	—	0.50
Z	2°		10°	
G1	0.410	0.430	10.42	10.92
K1	0.040	—	1.02	—

Motorola reserves the right to make changes without further notice to any products herein. Motorola makes no warranty, representation or guarantee regarding the suitability of its products for any particular purpose, nor does Motorola assume any liability arising out of the application or use of any product or circuit, and specifically disclaims any and all liability, including without limitation consequential or incidental damages. "Typical" parameters which may be provided in Motorola data sheets and/or specifications can and do vary in different applications and actual performance may vary over time. All operating parameters, including "Typicals" must be validated for each customer application by customer's technical experts. Motorola does not convey any license under its patent rights nor the rights of others. Motorola products are not designed, intended, or authorized for use as components in systems intended for surgical implant into the body, or other applications intended to support or sustain life, or for any other application in which the failure of the Motorola product could create a situation where personal injury or death may occur. Should Buyer purchase or use Motorola products for any such unintended or unauthorized application, Buyer shall indemnify and hold Motorola and its officers, employees, subsidiaries, affiliates, and distributors harmless against all claims, costs, damages, and expenses, and reasonable attorney fees arising out of, directly or indirectly, any claim of personal injury or death associated with such unintended or unauthorized use, even if such claim alleges that Motorola was negligent regarding the design or manufacture of the part. Motorola and  are registered trademarks of Motorola, Inc. Motorola, Inc. is an Equal Opportunity/Affirmative Action Employer.

How to reach us:

USA/EUROPE/Locations Not Listed: Motorola Literature Distribution;
P.O. Box 20912; Phoenix, Arizona 85036. 1-800-441-2447 or 602-303-5454

MFAX: RMFAX0@email.sps.mot.com – TOUCHTONE 602-244-6609
INTERNET: <http://Design-NET.com>

JAPAN: Nippon Motorola Ltd.; Tatsumi-SPD-JLDC, 6F Seibu-Butsuryu-Center,
3-14-2 Tatsumi Koto-Ku, Tokyo 135, Japan. 03-81-3521-8315

ASIA/PACIFIC: Motorola Semiconductors H.K. Ltd.; 8B Tai Ping Industrial Park,
51 Ting Kok Road, Tai Po, N.T., Hong Kong. 852-26629298



Copyright © Each Manufacturing Company.

All Datasheets cannot be modified without permission.

This datasheet has been download from :

www.AllDataSheet.com

100% Free DataSheet Search Site.

Free Download.

No Register.

Fast Search System.

www.AllDataSheet.com