

# Dual Differential 2:1 Multiplexer

The MC100LVEL56 is a dual, fully differential 2:1 multiplexer. The MC100EL56 is pin and functionally equivalent to the MC100LVEL56 but is specified for operation at the standard 100E ECL voltage supply. The differential data path makes the device ideal for multiplexing low skew clock or other skew sensitive signals. Multiple  $V_{BB}$  pins are provided to ease AC coupling input signals (for more information on AC coupling ECL signals refer to the interfacing section of the ECLinPS data book DL140/D).

The device features both individual and common select inputs to address both data path and random logic applications.

The differential inputs have special circuitry which ensures device stability under open input conditions. When both differential inputs are left open the D input will pull down to  $V_{EE}$ . The D input will bias around  $V_{CC}/2$  forcing the Q output LOW.

- Differential Inputs and Outputs
- 20-Lead SOIC Packaging
- 440ps Typical Propagation Delays
- Separate and Common Select
- Supports Both Standard and Low Voltage 100K ECL
- Internal Input Pulldowns
- >2000V ESD Protection

Logic Diagram and Pinout: 20-Lead SOIC (Top View)

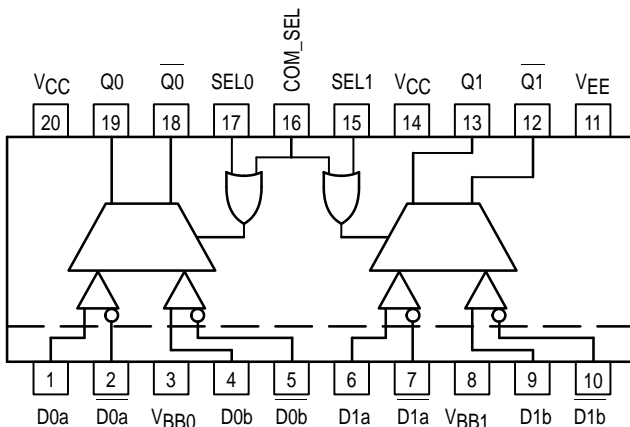

## MC100LVEL56 MC100EL56

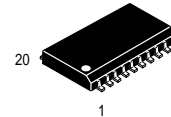

**DW SUFFIX**  
PLASTIC SOIC PACKAGE  
CASE 751D-04

### TRUTH TABLE

SEL	Data
H	a
L	b

### PIN NAMES

Pins	Function
D0a–D1a	Input Data a
D0b–D1b	Input Data b
SEL0–SEL1	Individual Select Input
COM_SEL	Common Select Input
$\underline{Q0}$ – $\underline{Q1}$	True Outputs
Q0–Q1	Inverted Outputs



# MC100LVEL56 MC100EL56

## MC100LVEL56

### DC CHARACTERISTICS ( $V_{EE} = -3.0V$ to $-3.8V$ ; $V_{CC} = GND$ )

Symbol	Characteristic	-40°C			0°C			25°C			85°C			Unit
		Min	Typ	Max	Min	Typ	Max	Min	Typ	Max	Min	Typ	Max	
$I_{EE}$	Power Supply Current		20	24		20	24		20	24		20	24	mA
$V_{BB}$	Output Reference Voltage	-1.38		-1.26	-1.38		-1.26	-1.38		-1.26	-1.38		-1.26	V
$I_{IH}$	Input HIGH Current			150			150			150			150	$\mu A$
$I_{iNL}$	Input LOW Current	$D_{\uparrow}$ $D_{\downarrow}$	0.5 -600		0.5 -600			0.5 -600			0.5 -600			$\mu A$
$V_{PP(DC)}$	Input Sensitivity <sup>1</sup>	50			50			50			50			V

1. Differential input voltage required to obtain a full ECL swing on the outputs.

## MC100LVEL56

### AC CHARACTERISTICS ( $V_{EE} = -3.0V$ to $-3.8V$ ; $V_{CC} = GND$ )

Symbol	Characteristic	-40°C			0°C			25°C			85°C			Unit	
		Min	Typ	Max	Min	Typ	Max	Min	Typ	Max	Min	Typ	Max		
$t_{PLH}$ $t_{PHL}$	Propagation Delay to Output	D (Diff) D (SE) SEL COMSEL	340 290 430 430		540 590 730 730	350 300 440 440		550 600 740 740	360 310 440 440		560 610 740 740	380 330 450 450		580 630 750 750	ps
$t_{SKEW}$	Within-Device Skew <sup>1</sup>		40	80		40	80		40	80		40	80	ps	
$t_{SKEW}$	Duty Cycle Skew <sup>2</sup>			100			100			100			100	ps	
$V_{PP(AC)}$	Minimum Input Swing <sup>3</sup>		150		1000	150		1000	150		1000	150		1000	mV
$V_{CMR}$	Common Mode Range <sup>4</sup>	$V_{PP} < 500mV$ $V_{PP} \geq 500mV$	-2.0 -1.8		-0.4 -0.4	-2.1 -1.9		-0.4 -0.4	-2.1 -1.9		-0.4 -0.4	-2.1 -1.9		-0.4 -0.4	V
$t_r$ $t_f$	Output Rise/Fall Times Q (20% – 80%)		200		540	200		540	200		540	200		540	ps

1. Within-device skew is defined as identical transitions on similar paths through a device.

2. Duty cycle skew is defined only for differential operation when the delays are measured from the cross point of the inputs to the cross point of the outputs.

3. Minimum input swing for which AC parameters are guaranteed.

4. The CMR range is referenced to the most positive side of the differential input signal. Normal operation is obtained if the HIGH level falls within the specified range and the peak-to-peak voltage lies between  $V_{PPmin}$  and 1V. The lower end of the CMR range varies 1:1 with  $V_{EE}$ . The numbers in the spec table assume a nominal  $V_{EE} = -3.3V$ . Note for PECL operation, the  $V_{CMR(min)}$  will be fixed at  $3.3V - |V_{CMR(min)}|$ .

**MC100EL56****DC CHARACTERISTICS** ( $V_{EE} = -4.2V$  to  $-5.5V$ ;  $V_{CC} = GND$ )

Symbol	Characteristic	-40°C			0°C			25°C			85°C			Unit
		Min	Typ	Max	Min	Typ	Max	Min	Typ	Max	Min	Typ	Max	
$I_{EE}$	Power Supply Current		20	24		20	24		20	24		20	24	mA
$V_{BB}$	Output Reference Voltage	-1.38		-1.26	-1.38		-1.26	-1.38		-1.26	-1.38		-1.26	V
$I_{IH}$	Input HIGH Current			150			150			150			150	$\mu A$
$I_{INL}$	Input LOW Current	$D_{\uparrow}$ $D_{\downarrow}$	0.5 -600		0.5 -600			0.5 -600			0.5 -600			$\mu A$
$V_{PP(DC)}$	Input Sensitivity <sup>1</sup>	50			50			50			50			V

1. Differential input voltage required to obtain a full ECL swing on the outputs.

**MC100EL56****AC CHARACTERISTICS** ( $V_{EE} = -4.2V$  to  $-5.5V$ ;  $V_{CC} = GND$ )

Symbol	Characteristic	-40°C			0°C			25°C			85°C			Unit	
		Min	Typ	Max	Min	Typ	Max	Min	Typ	Max	Min	Typ	Max		
$t_{PLH}$ $t_{PHL}$	Propagation Delay to Output	D (Diff) D (SE) SEL COMSEL	340 290 430 430		540 590 730 730	350 300 440 440		550 600 740 740	360 310 440 440		560 610 740 740	380 330 450 450		580 630 750 750	ps
$t_{SKEW}$	Within-Device Skew <sup>1</sup>		40	80		40	80		40	80		40	80	ps	
$t_{SKEW}$	Duty Cycle Skew <sup>2</sup>			100			100			100			100	ps	
$V_{PP(AC)}$	Minimum Input Swing <sup>3</sup>		150	1000	150		1000	150		1000	150		1000	mV	
$V_{CMR}$	Common Mode Range <sup>4</sup>	$V_{PP} < 500mV$ $V_{PP} \geq 500mV$	-3.2 -3.0		-0.4 -0.4	-3.3 -3.1		-0.4 -0.4	-3.3 -3.1		-0.4 -0.4	-3.3 -3.1		-0.4 -0.4	V
$t_r$ $t_f$	Output Rise/Fall Times Q (20% – 80%)		200		540	200		540	200		540	200		540	ps

1. Within-device skew is defined as identical transitions on similar paths through a device.

2. Duty cycle skew is defined only for differential operation when the delays are measured from the cross point of the inputs to the cross point of the outputs.

3. Minimum input swing for which AC parameters are guaranteed.

4. The CMR range is referenced to the most positive side of the differential input signal. Normal operation is obtained if the HIGH level falls within the specified range and the peak-to-peak voltage lies between  $V_{PPmin}$  and 1V. The lower end of the CMR range varies 1:1 with  $V_{EE}$ . The numbers in the spec table assume a nominal  $V_{EE} = -4.5V$ . Note for PECL operation, the  $V_{CMR(min)}$  will be fixed at  $5.0V - |V_{CMR(min)}|$ .

OUTLINE DIMENSIONS

DW SUFFIX  
PLASTIC SOIC PACKAGE  
CASE 751D-04  
ISSUE E

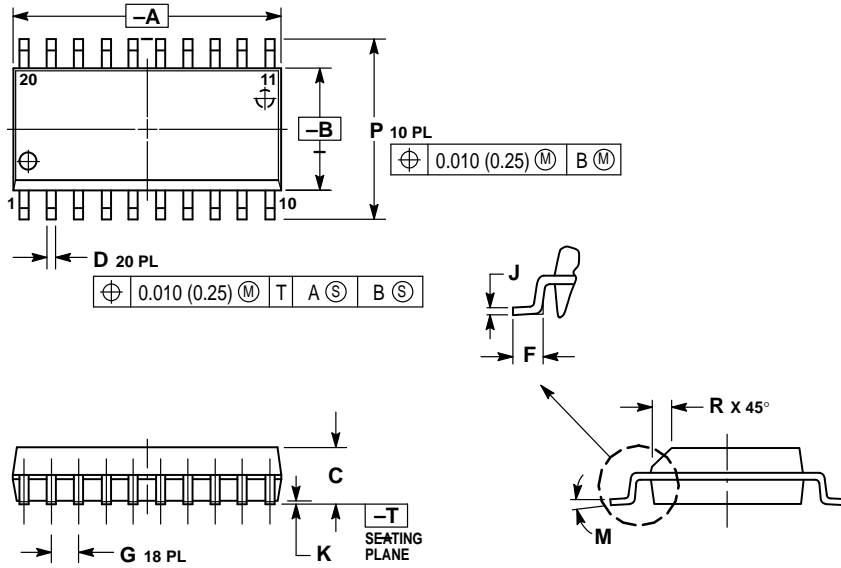

- NOTES:
1. DIMENSIONING AND TOLERANCING PER ANSI Y14.5M, 1982.
  2. CONTROLLING DIMENSION: MILLIMETER.
  3. DIMENSIONS A AND B DO NOT INCLUDE MOLD PROTRUSION.
  4. MAXIMUM MOLD PROTRUSION 0.150 (0.006) PER SIDE.
  5. DIMENSION D DOES NOT INCLUDE DAMBAR PROTRUSION. ALLOWABLE DAMBAR PROTRUSION SHALL BE 0.13 (0.005) TOTAL IN EXCESS OF D DIMENSION AT MAXIMUM MATERIAL CONDITION.

DIM	MILLIMETERS		INCHES	
	MIN	MAX	MIN	MAX
A	12.65	12.95	0.499	0.510
B	7.40	7.60	0.292	0.299
C	2.35	2.65	0.093	0.104
D	0.35	0.49	0.014	0.019
F	0.50	0.90	0.020	0.035
G	1.27 BSC		0.050 BSC	
J	0.25	0.32	0.010	0.012
K	0.10	0.25	0.004	0.009
M	0°	7°	0°	7°
P	10.05	10.55	0.395	0.415
R	0.25	0.75	0.010	0.029

Motorola reserves the right to make changes without further notice to any products herein. Motorola makes no warranty, representation or guarantee regarding the suitability of its products for any particular purpose, nor does Motorola assume any liability arising out of the application or use of any product or circuit, and specifically disclaims any and all liability, including without limitation consequential or incidental damages. "Typical" parameters which may be provided in Motorola data sheets and/or specifications can and do vary in different applications and actual performance may vary over time. All operating parameters, including "Typicals" must be validated for each customer application by customer's technical experts. Motorola does not convey any license under its patent rights nor the rights of others. Motorola products are not designed, intended, or authorized for use as components in systems intended for surgical implant into the body, or other applications intended to support or sustain life, or for any other application in which the failure of the Motorola product could create a situation where personal injury or death may occur. Should Buyer purchase or use Motorola products for any such unintended or unauthorized application, Buyer shall indemnify and hold Motorola and its officers, employees, subsidiaries, affiliates, and distributors harmless against all claims, costs, damages, and expenses, and reasonable attorney fees arising out of, directly or indirectly, any claim of personal injury or death associated with such unintended or unauthorized use, even if such claim alleges that Motorola was negligent regarding the design or manufacture of the part. Motorola and are registered trademarks of Motorola, Inc. Motorola, Inc. is an Equal Opportunity/Affirmative Action Employer.

How to reach us:

USA/EUROPE/Locations Not Listed: Motorola Literature Distribution; P.O. Box 20912; Phoenix, Arizona 85036. 1-800-441-2447 or 602-303-5454

JAPAN: Nippon Motorola Ltd.; Tatsumi-SPD-JLDC, 6F Seibu-Butsuryu-Center, 3-14-2 Tatsumi Koto-Ku, Tokyo 135, Japan. 03-81-3521-8315

MFAX: RMFAX0@email.sps.mot.com - TOUCHTONE 602-244-6609  
INTERNET: <http://Design-NET.com>

ASIA/PACIFIC: Motorola Semiconductors H.K. Ltd.; 8B Tai Ping Industrial Park, 51 Ting Kok Road, Tai Po, N.T., Hong Kong. 852-26629298



Copyright © Each Manufacturing Company.

All Datasheets cannot be modified without permission.

This datasheet has been download from :

[www.AllDataSheet.com](http://www.AllDataSheet.com)

100% Free DataSheet Search Site.

Free Download.

No Register.

Fast Search System.

[www.AllDataSheet.com](http://www.AllDataSheet.com)