

MC10EP446, MC100EP446

3.3 V/5 V 8-Bit CMOS/ECL/TTL Data Input Parallel/Serial Converter

Description

The MC10/100EP446 is an integrated 8-bit parallel to serial data converter. The device is designed with unique circuit topology to operate for NRZ data rates up to 3.2 Gb/s. The conversion sequence from parallel data into a serial data stream is from bit D0 to D7. The parallel input pins D0–D7 are configurable to be threshold controlled by CMOS, ECL, or TTL level signals. The serial data rate output can be selected at internal clock data rate or twice the internal clock data rate using the CKSEL pin.

Control pins are provided to reset (SYNC) and disable internal clock circuitry (CKEN). In either CKSEL modes, the internal flip-flops are triggered on the rising edge for CLK and the multiplexers are switched on the falling edge of CLK, therefore, all associated specification limits are referenced to the negative edge of the clock input. Additionally, V_{BB} pin is provided for single-ended input condition.

The 100 Series devices contain temperature compensation network.

Features

- 3.2 Gb/s Typical Data Rate Capability
- Differential Clock and Serial Outputs
- V_{BB} Output for Single-ended Input Applications
- Asynchronous Data Reset (SYNC)
- PECL Mode Operating Range:
 $V_{CC} = 3.0\text{ V to }5.5\text{ V with }V_{EE} = 0\text{ V}$
- NECL Mode Operating Range:
 $V_{CC} = 0\text{ V with }V_{EE} = -3.0\text{ V to }-5.5\text{ V}$
- Open Input Default State
- Safety Clamp on Inputs
- Parallel Interface Can Support PECL, TTL or CMOS
- Pb-Free Packages are Available*



ON Semiconductor®

<http://onsemi.com>

MARKING DIAGRAMS*

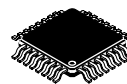

LQFP-32
FA SUFFIX
CASE 873A

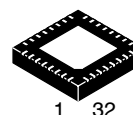
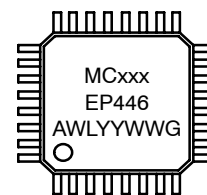

QFN32
MN SUFFIX
CASE 488AM



xxx = 10 or 100
A = Assembly Location
WL, L = Wafer Lot
YY, Y = Year
WW, W = Work Week
G or ■ = Pb-Free Package
(Note: Microdot may be in either location)

*For additional marking information, refer to Application Note AND8002/D.

ORDERING INFORMATION

See detailed ordering and shipping information in the package dimensions section on page 18 of this data sheet.

*For additional information on our Pb-Free strategy and soldering details, please download the ON Semiconductor Soldering and Mounting Techniques Reference Manual, SOLDERRM/D.

MC10EP446, MC100EP446

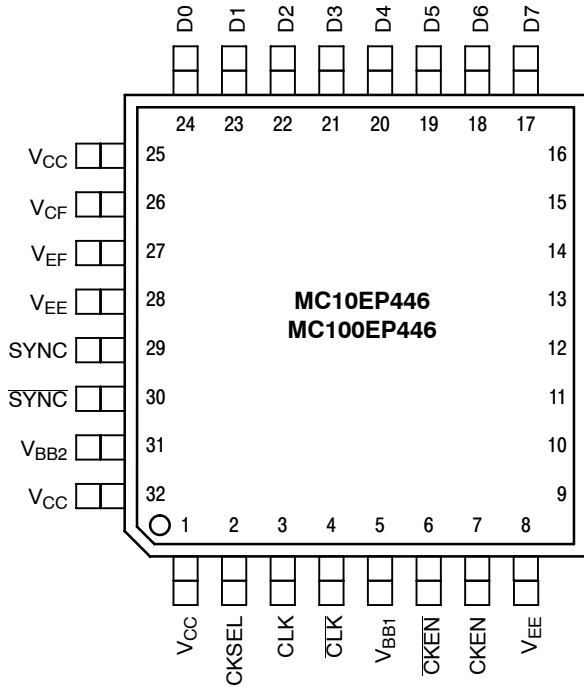

Warning: All V_{CC} and V_{EE} pins must be externally connected to Power Supply to guarantee proper operation.

Figure 1. LQFP-32 Pinout (Top View)

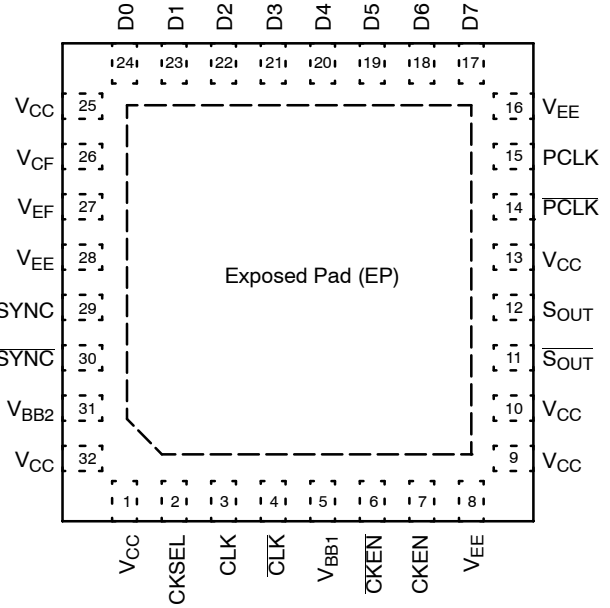

Figure 2. QFN-32 Pinout (Top View)

Table 1. PIN DESCRIPTION

PIN	FUNCTION
D0*-D7*	ECL, CMOS, or TTL Parallel Data Input
S _{OUT} , \overline{S}_{OUT}	ECL Differential Serial Data Output
CLK*, \overline{CLK} *	ECL Differential Clock Input
PCLK, \overline{PCLK}	ECL Differential Parallel Clock Output
SYNC*, \overline{SYNC} **	ECL Conversion Synchronizing Differential Input (Reset)***
CKSEL*	ECL Clock Input Selector
CKEN*, \overline{CKEN} *	ECL Clock Enable Differential Input
V _{CF}	ECL, CMOS, or TTL Input Selector
V _{EF}	ECL Reference Mode Connection
V _{BB1} , V _{BB2}	Reference Voltage Output
V _{CC}	Positive Supply
V _{EE}	Negative Supply

* Pins will default LOW when left open.

**Pins will default HIGH when left open.

***The rising edge of SYNC will asynchronously reset the internal circuitry. The falling edge of the SYNC followed by the falling edge of CLK initiates the conversion process synchronously on the next rising edge of CLK.

MC10EP446, MC100EP446

Table 2. TRUTH TABLE

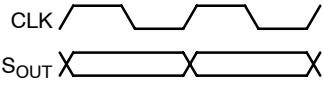
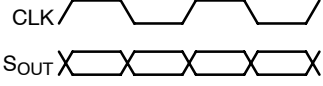
Pin	Function	
	HIGH	LOW
CKSEL	S _{OUT} : PCLK = 8:1 CLK: S _{OUT} = 1:1 	S _{OUT} : PCLK = 8:1 CLK: S _{OUT} = 1:2 
CKEN	Synchronously Disables Normal Parallel to Serial Conversion	Synchronously Enables Normal Parallel to Serial Conversion
SYNC	Asynchronously Resets Internal Flip-Flops*	Synchronous Enable

*The rising edge of SYNC will asynchronously reset the internal circuitry. The falling edge of the SYNC followed by the falling edge of CLK initiates the conversion process synchronously on the next rising edge of CLK.

Table 3. INPUT VOLTAGE LEVEL SELECTION TABLE

Input Function	Connect To V _{CF} Pin
ECL Mode	V _{EF} Pin
CMOS Mode	No Connect
TTL Mode*	1.5 V ± 100 mV

*For TTL Mode, if no external voltage can be provided, the reference voltage can be provided by connecting the appropriate resistor between V_{CF} and V_{EE} pins.

Table 4. DATA INPUT OPERATING VOLTAGE TABLE

Power Supply (V _{CC} , V _{EE})	Data Inputs (D [0:7])			
	CMOS	TTL	PECL	NECL
PECL	✓	✓	✓	N/A
NECL	N/A	N/A	N/A	✓

Power Supply	Resistor Value 10% (Tolerance)
3.3 V	1.5 kΩ
5.0 V	500 Ω

MC10EP446, MC100EP446

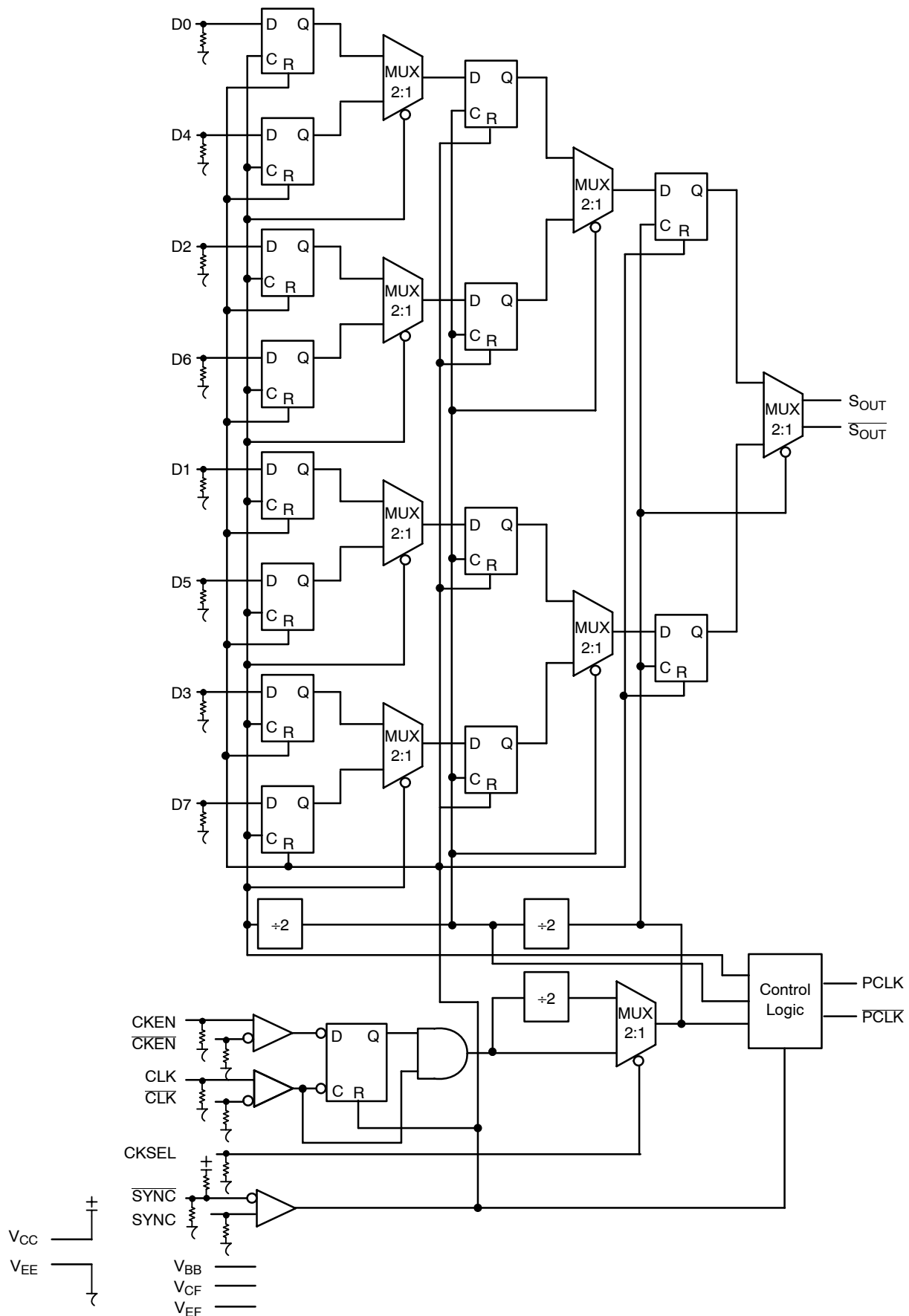

Figure 3. Logic Diagram

MC10EP446, MC100EP446

Table 5. ATTRIBUTES

Characteristics		Value	
Internal Input Pulldown Resistor		75 kΩ	
Internal Input Pullup Resistor		37.5 kΩ	
ESD Protection	Human Body Model	> 2 kV	
	Machine Model	> 100 V	
	Charged Device Model	> 2 kV	
Moisture Sensitivity, Indefinite Time Out of Drypack (Note 1)		Pb Pkg	Pb-Free Pkg
	LQFP-32	Level 2	Level 2
	QFN-32	-	Level 1
Flammability Rating	Oxygen Index: 28 to 34	UL 94 V-0 @ 0.125 in	
Transistor Count		962 Devices	
Meets or exceeds JEDEC Spec EIA/JESD78 IC Latchup Test			

1. For additional information, see Application Note AND8003/D.

Table 6. MAXIMUM RATINGS

Symbol	Parameter	Condition 1	Condition 2	Rating	Unit
V _{CC}	PECL Mode Power Supply	V _{EE} = 0 V		6	V
V _{EE}	NECL Mode Power Supply	V _{CC} = 0 V		-6	V
V _I	PECL Mode Input Voltage	V _{EE} = 0 V	V _I ≤ V _{CC}	6	V
	NECL Mode Input Voltage	V _{CC} = 0 V	V _I ≥ V _{EE}	-6	
I _{out}	Output Current	Continuous Surge		50	mA
				100	
I _{BB}	V _{BB} Sink/Source			± 0.5	mA
T _A	Operating Temperature Range			-40 to +85	°C
T _{stg}	Storage Temperature Range			-65 to +150	°C
θ _{JA}	Thermal Resistance (Junction-to-Ambient)	0 lfpm	LQFP-32	80	°C/W
		500 lfpm	LQFP-32	55	
θ _{JC}	Thermal Resistance (Junction-to-Case)	Standard Board	LQFP-32	12 to 17	°C/W
θ _{JA}	Thermal Resistance (Junction-to-Ambient)	0 lfpm	QFN-32	31	°C/W
			500 lfpm	QFN-32	
θ _{JC}	Thermal Resistance (Junction-to-Case)	2S2P	QFN-32	12	°C/W
T _{sol}	Wave Solder	Pb		265	°C
		Pb-Free		265	

Stresses exceeding Maximum Ratings may damage the device. Maximum Ratings are stress ratings only. Functional operation above the Recommended Operating Conditions is not implied. Extended exposure to stresses above the Recommended Operating Conditions may affect device reliability.

MC10EP446, MC100EP446

Table 7. 10EP DC CHARACTERISTICS, PECL $V_{CC} = 3.3\text{ V}$, $V_{EE} = 0\text{ V}$ (Note 2)

Symbol	Characteristic	-40°C			25°C			85°C			Unit	
		Min	Typ	Max	Min	Typ	Max	Min	Typ	Max		
I_{EE}	Power Supply Current	90	110	140	90	110	140	95	115	145	mA	
V_{OH}	Output HIGH Voltage (Note 3)	2165	2290	2415	2230	2355	2480	2290	2415	2540	mV	
V_{OL}	Output LOW Voltage (Note 3)	1365	1490	1615	1430	1555	1680	1490	1615	1740	mV	
V_{IH}	Input HIGH Voltage (Single-Ended)	CMOS	2000		3300	2000		3300	2000		3300	mV
		PECL	2090		3300	2155		3300	2215		3300	
		TTL	2000		3300	2000		3300	2000		3300	
V_{IL}	Input LOW Voltage (Single-Ended)	CMOS	0		800	0		800	0		800	mV
		PECL	1365		1690	1460		1755	1490		1815	
		TTL	0		800	0		800	0		800	
V_{BB}	Output Voltage Reference	1790	1840	1990	1855	1905	2055	1915	1965	2115	mV	
V_{IHCMR}	Input HIGH Voltage Common Mode Range (Differential Configuration) (Note 4)	2.0		3.3	2.0		3.3	2.0		3.3	V	
I_{IH}	Input HIGH Current			150			150			150	μA	
I_{IL}	Input LOW Current (All Except SYNC, $\overline{\text{SYNC}}$)	SYNC, $\overline{\text{SYNC}}$	0.5		0.5			0.5			μA	
			-150		0.5		-150		0.5			-150

NOTE: Device will meet the specifications after thermal equilibrium has been established when mounted in a test socket or printed circuit board with maintained transverse airflow greater than 500 lfm. Electrical parameters are guaranteed only over the declared operating temperature range. Functional operation of the device exceeding these conditions is not implied. Device specification limit values are applied individually under normal operating conditions and not valid simultaneously.

2. Input and output parameters vary 1:1 with V_{CC} . V_{EE} can vary +0.3 V to -2.2 V.
3. All loading with 50 Ω to $V_{CC} - 2.0\text{ V}$.
4. V_{IHCMR} min varies 1:1 with V_{EE} . V_{IHCMR} max varies 1:1 with V_{CC} . The V_{IHCMR} range is referenced to the most positive side of the differential input signal.

MC10EP446, MC100EP446

Table 8. 10EP DC CHARACTERISTICS, PECL $V_{CC} = 5.0\text{ V}$, $V_{EE} = 0\text{ V}$ (Note 5)

Symbol	Characteristic	-40°C			25°C			85°C			Unit	
		Min	Typ	Max	Min	Typ	Max	Min	Typ	Max		
I_{EE}	Power Supply Current	90	110	140	90	110	140	95	115	145	mA	
V_{OH}	Output HIGH Voltage (Note 6)	3865	3950	4115	3930	4055	4180	3990	4115	4240	mV	
V_{OL}	Output LOW Voltage (Note 6)	3065	3190	3315	3130	3255	3380	3190	3315	3440	mV	
V_{IH}	Input HIGH Voltage (Single-Ended)	CMOS	3500		5000	3500		5000	3500		5000	mV
		PECL	3790		5000	3855		5000	3915		5000	
		TTL	2000		5000	2000		5000	2000		5000	
V_{IL}	Input LOW Voltage (Single-Ended)	CMOS	0		1500	0		1500	0		1500	mV
		PECL	3065		3390	3130		3455	3190		3915	
		TTL	0		800	0		800	0		800	
V_{BB}	Output Voltage Reference	3490	3540	3690	3555	3605	3755	3615	3665	3815	mV	
V_{IHCMR}	Input HIGH Voltage Common Mode Range (Differential Configuration) (Note 7)	2.0		5.0	2.0		5.0	2.0		5.0	V	
I_{IH}	Input HIGH Current			150			150			150	μA	
I_{IL}	Input LOW Current (All Except SYNC, $\overline{\text{SYNC}}$)	SYNC, $\overline{\text{SYNC}}$	0.5		0.5			0.5			μA	
			-150		0.5		-150		0.5			-150

NOTE: Device will meet the specifications after thermal equilibrium has been established when mounted in a test socket or printed circuit board with maintained transverse airflow greater than 500 lfm. Electrical parameters are guaranteed only over the declared operating temperature range. Functional operation of the device exceeding these conditions is not implied. Device specification limit values are applied individually under normal operating conditions and not valid simultaneously.

5. Input and output parameters vary 1:1 with V_{CC} . V_{EE} can vary +2.0 V to -0.5 V.
6. All loading with 50 Ω to $V_{CC} - 2.0\text{ V}$.
7. V_{IHCMR} min varies 1:1 with V_{EE} . V_{IHCMR} max varies 1:1 with V_{CC} . The V_{IHCMR} range is referenced to the most positive side of the differential input signal.

MC10EP446, MC100EP446

Table 9. 10EP DC CHARACTERISTICS, NECL $V_{CC} = 0\text{ V}$, $V_{EE} = -5.5\text{ V}$ to -3.0 V (Note 8)

Symbol	Characteristic	-40°C			25°C			85°C			Unit
		Min	Typ	Max	Min	Typ	Max	Min	Typ	Max	
I_{EE}	Power Supply Current	90	110	140	90	110	140	95	115	145	mA
V_{OH}	Output HIGH Voltage (Note 9)	-1135	-1010	-885	-1070	-945	-820	-1010	-885	-760	mV
V_{OL}	Output LOW Voltage (Note 9)	-1935	-1810	-1685	-1870	-1745	-1620	-1810	-1685	-1560	mV
V_{IH}	Input HIGH Voltage (Single-Ended)	-1210		-885	-1145		-820	-1085		-760	mV
V_{IL}	Input LOW Voltage (Single-Ended)	-1935		-1610	-1870		-1545	-1810		-1485	mV
V_{BB}	Output Voltage Reference	-1510	-1460	-1310	-1445	-1395	-1245	-1385	-1335	-1185	mV
V_{IHCMR}	Input HIGH Voltage Common Mode Range (Differential Configuration) (Note 10)	$V_{EE}+2.0$		0.0	$V_{EE}+2.0$		0.0	$V_{EE}+2.0$		0.0	V
I_{IH}	Input HIGH Current			150			150			150	μA
I_{IL}	Input LOW Current (All Except SYNC, $\overline{\text{SYNC}}$ SYNC, $\overline{\text{SYNC}}$)	0.5 -150		0.5	0.5 -150		0.5	0.5 -150		0.5	μA

NOTE: Device will meet the specifications after thermal equilibrium has been established when mounted in a test socket or printed circuit board with maintained transverse airflow greater than 500 lfm. Electrical parameters are guaranteed only over the declared operating temperature range. Functional operation of the device exceeding these conditions is not implied. Device specification limit values are applied individually under normal operating conditions and not valid simultaneously.

8. Input and output parameters vary 1:1 with V_{CC} .

9. All loading with $50\ \Omega$ to $V_{CC} - 2.0\text{ V}$.

10. V_{IHCMR} min varies 1:1 with V_{EE} . V_{IHCMR} max varies 1:1 with V_{CC} . The V_{IHCMR} range is referenced to the most positive side of the differential input signal.

Table 10. 100EP DC CHARACTERISTICS, PECL $V_{CC} = 3.3\text{ V}$, $V_{EE} = 0\text{ V}$ (Note 11)

Symbol	Characteristic	-40°C			25°C			85°C			Unit
		Min	Typ	Max	Min	Typ	Max	Min	Typ	Max	
I_{EE}	Power Supply Current	90	110	130	90	110	130	95	115	135	mA
V_{OH}	Output HIGH Voltage (Note 12)	2155	2280	2405	2155	2280	2405	2155	2280	2405	mV
V_{OL}	Output LOW Voltage (Note 12)	1355	1480	1605	1355	1480	1605	1355	1480	1605	mV
V_{IH}	Input HIGH Voltage (Single-Ended)										
	CMOS	2000		3300	2000		3300	2000		3300	mV
	PECL	2075		3300	2075		3300	2075		3300	
	TTL	2000		3300	2000		3300	2000		3300	
V_{IL}	Input LOW Voltage (Single-Ended)										
	CMOS	0		800	0		800	0		800	mV
	PECL	1355		1675	1355		1675	1355		1675	
	TTL	0		800	0		800	0		800	
V_{BB}	Output Voltage Reference	1775	1875	1975	1775	1875	1975	1775	1875	1975	mV
V_{IHCMR}	Input HIGH Voltage Common Mode Range (Differential Configuration) (Note 13)	2.0		3.3	2.0		3.3	2.0		3.3	V
I_{IH}	Input HIGH Current			150			150			150	μA
I_{IL}	Input LOW Current	0.5			0.5			0.5			μA

NOTE: Device will meet the specifications after thermal equilibrium has been established when mounted in a test socket or printed circuit board with maintained transverse airflow greater than 500 lfm. Electrical parameters are guaranteed only over the declared operating temperature range. Functional operation of the device exceeding these conditions is not implied. Device specification limit values are applied individually under normal operating conditions and not valid simultaneously.

11. Input and output parameters vary 1:1 with V_{CC} . V_{EE} can vary +0.3 V to -2.2 V.

12. All loading with $50\ \Omega$ to $V_{CC} - 2.0\text{ V}$.

13. V_{IHCMR} min varies 1:1 with V_{EE} . V_{IHCMR} max varies 1:1 with V_{CC} . The V_{IHCMR} range is referenced to the most positive side of the differential input signal.

MC10EP446, MC100EP446

Table 11. 100EP DC CHARACTERISTICS, PECL $V_{CC} = 5.0\text{ V}$, $V_{EE} = 0\text{ V}$ (Note 14)

Symbol	Characteristic	-40°C			25°C			85°C			Unit
		Min	Typ	Max	Min	Typ	Max	Min	Typ	Max	
I_{EE}	Power Supply Current	90	110	130	90	110	130	95	115	135	mA
V_{OH}	Output HIGH Voltage (Note 15)	3855	3980	4105	3855	3980	4105	3855	3980	4105	mV
V_{OL}	Output LOW Voltage (Note 15)	3055	3180	3305	3055	3180	3305	3055	3180	3305	mV
V_{IH}	Input HIGH Voltage (Single-Ended)										
	CMOS	3500		5000	3500		5000	3500		5000	mV
	PECL	3775		5000	3775		5000	3775		5000	
	TTL	2000		5000	2000		5000	2000		5000	
V_{IL}	Input LOW Voltage (Single-Ended)										
	CMOS	0		1500	0		1500	0		1500	mV
	PECL	3055		3375	3055		3375	3055		3375	
	TTL	0		800	0		800	0		800	
V_{BB}	Output Voltage Reference	3475	3575	3675	3475	3575	3675	3475	3575	3675	mV
V_{IHCMR}	Input HIGH Voltage Common Mode Range (Differential Configuration) (Note 16)	2.0		5.0	2.0		5.0	2.0		5.0	V
I_{IH}	Input HIGH Current			150			150			150	μA
I_{IL}	Input LOW Current	0.5			0.5			0.5			μA

NOTE: Device will meet the specifications after thermal equilibrium has been established when mounted in a test socket or printed circuit board with maintained transverse airflow greater than 500 lfm. Electrical parameters are guaranteed only over the declared operating temperature range. Functional operation of the device exceeding these conditions is not implied. Device specification limit values are applied individually under normal operating conditions and not valid simultaneously.

14. Input and output parameters vary 1:1 with V_{CC} . V_{EE} can vary +2.0 V to -0.5 V.

15. All loading with 50 Ω to $V_{CC} - 2.0\text{ V}$.

16. V_{IHCMR} min varies 1:1 with V_{EE} , V_{IHCMR} max varies 1:1 with V_{CC} . The V_{IHCMR} range is referenced to the most positive side of the differential input signal.

Table 12. 100EP DC CHARACTERISTICS, NECL $V_{CC} = 0\text{ V}$, $V_{EE} = -5.5\text{ V}$ to -3.0 V (Note 17)

Symbol	Characteristic	-40°C			25°C			85°C			Unit
		Min	Typ	Max	Min	Typ	Max	Min	Typ	Max	
I_{EE}	Power Supply Current	90	110	130	90	110	130	95	115	135	mA
V_{OH}	Output HIGH Voltage (Note 18)	-1145	-1020	-895	-1145	-1020	-895	-1145	-1020	-895	mV
V_{OL}	Output LOW Voltage (Note 18)	-1945	-1820	-1695	-1945	-1820	-1695	-1945	-1820	-1695	mV
V_{IH}	Input HIGH Voltage (Single-Ended)	-1225		-880	-1225		-880	-1225		-880	mV
V_{IL}	Input LOW Voltage (Single-Ended)	-1945		-1625	-1945		-1625	-1945		-1625	mV
V_{BB}	Output Voltage Reference	-1525	-1425	-1325	-1525	-1425	-1325	-1525	-1425	-1325	mV
V_{IHCMR}	Input HIGH Voltage Common Mode Range (Differential Configuration) (Note 19)	$V_{EE}+2.0$		0.0	$V_{EE}+2.0$		0.0	$V_{EE}+2.0$		0.0	V
I_{IH}	Input HIGH Current			150			150			150	μA
I_{IL}	Input LOW Current	0.5			0.5			0.5			μA

NOTE: Device will meet the specifications after thermal equilibrium has been established when mounted in a test socket or printed circuit board with maintained transverse airflow greater than 500 lfm. Electrical parameters are guaranteed only over the declared operating temperature range. Functional operation of the device exceeding these conditions is not implied. Device specification limit values are applied individually under normal operating conditions and not valid simultaneously.

17. Input and output parameters vary 1:1 with V_{CC} .

18. All loading with 50 Ω to $V_{CC} - 2.0\text{ V}$.

19. V_{IHCMR} min varies 1:1 with V_{EE} , V_{IHCMR} max varies 1:1 with V_{CC} . The V_{IHCMR} range is referenced to the most positive side of the differential input signal.

MC10EP446, MC100EP446

Table 13. AC CHARACTERISTICS $V_{CC} = 0\text{ V}$; $V_{EE} = -3.0\text{ V}$ to -5.5 V or $V_{CC} = 3.0\text{ V}$ to 5.5 V ; $V_{EE} = 0\text{ V}$ (Note 20)

Symbol	Characteristic	-40°C			25°C			85°C			Unit
		Min	Typ	Max	Min	Typ	Max	Min	Typ	Max	
f_{max}	Maximum Frequency (Figure 15)										GHz
	CKSEL High	3.2	3.4		3.2	3.4		3.2	3.4		
	CKSEL Low	1.6	1.7		1.6	1.7		1.6	1.7		
t_{PLH} , t_{PHL}	Propagation Delay to Output Differential CKSEL = 0										ps
	CLK TO S_{OUT} , CLK TO PCLK	650 700	750 800	850 900	700 750	800 850	900 950	725 775	850 900	975 1025	
	CKSEL = 1										ps
	CLK TO S_{OUT} , CLK TO PCLK	775 850	875 950	975 1050	825 900	925 1000	1025 1100	875 950	1000 1075	1125 1200	
t_S	Setup Time D to CLK+ (Figure 4)	-375	-425		-400	-450		-450	-500		ps
	SYNC- to CLK- (Figure 5)	200	140		200	140		200	140		
	CKEN+ to CLK- (Figure 6)	70	40		70	40		70	40		
t_H	Hold Time D to CLK+ (Figure 4)	-525	-575		-550	-600		-600	-650		ps
	SYNC- to CLK- (Figure 5)	0			0			0			
	CLK- to CKEN- (Figure 6)	75	45		75	45		75	45		
t_{pw}	Minimum Pulse Width (Note 22)										ps
	Data (D0-D7)	150			150			150			
	SYNC CKEN	200 145			200 145			200 145			
t_{JITTER}	Random Clock Jitter (RMS) $\leq f_{max}$ Typ		0.2	< 1		0.2	< 1		0.2	< 1	ps
V_{PP}	Input Differential Voltage Swing (Note 21)	150	800	1200	150	800	1200	150	800	1200	mV
t_r t_f	Output Rise/Fall Times (20% - 80%) S_{OUT}	50	100	150	70	120	170	90	140	190	ps

NOTE: Device will meet the specifications after thermal equilibrium has been established when mounted in a test socket or printed circuit board with maintained transverse airflow greater than 500 lfpm. Electrical parameters are guaranteed only over the declared operating temperature range. Functional operation of the device exceeding these conditions is not implied. Device specification limit values are applied individually under normal operating conditions and not valid simultaneously.

20. Measured using a 750 mV source, 50% duty cycle clock source. All loading with $50\ \Omega$ to $V_{CC} - 2.0\text{ V}$.

21. $V_{PP}(\text{min})$ is the minimum input swing for which AC parameters are guaranteed.

22. The minimum pulse width is valid only if the setup and hold times are respected.

MC10EP446, MC100EP446

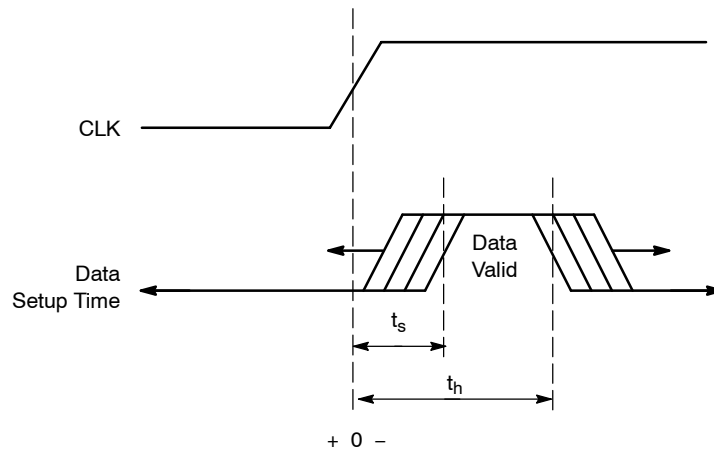

Figure 4. Setup and Hold Time for Data

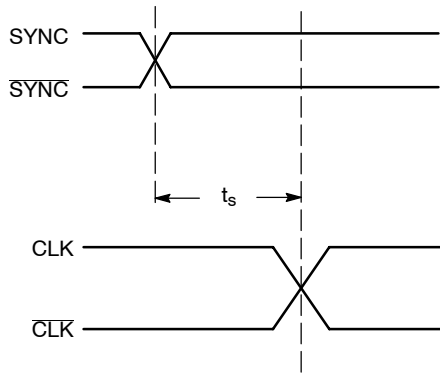

Figure 5. Setup Time for SYNC

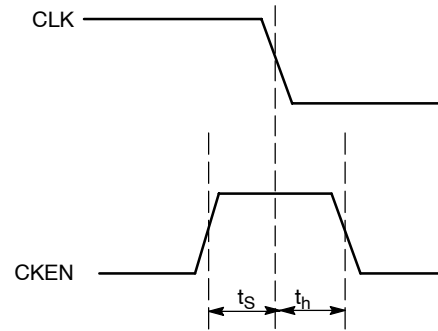

Figure 6. Setup and Hold Time for CKEN

MC10EP446, MC100EP446

APPLICATION INFORMATION

The MC10/100EP446 is an integrated 8:1 parallel to serial converter. An attribute for EP446 is that the parallel inputs D0–D7 (Pins 17 – 24) can be configured to accept either CMOS, ECL, or TTL level signals by a combination of interconnects between V_{EF} (Pin 27) and V_{CF} (Pin 26) pins. For CMOS input levels, leave V_{EF} and V_{CF} open. For ECL operation, short V_{CF} and V_{EF} (Pins 26 and 27). For TTL operation, connect a 1.5 V supply reference to V_{CF} and leave the V_{EF} pin open. The 1.5 V reference voltage to V_{CF} pin can be accomplished by placing a 1.5 k Ω or 500 Ω between V_{CF} and V_{EE} for 3.3 V or 5.0 V power supplies, respectively.

Note: all pins requiring ECL voltage inputs must have a 50 Ω terminating resistor to V_{TT} ($V_{TT} = V_{CC} - 2.0$ V).

The CKSEL input (Pin 2) is provided to enable the user to select the serial data rate output between internal clock data rate or twice the internal clock data rate. For CKSEL LOW operation, the time from when the parallel data is latched ① to when the data is seen on the SOUT ② is on the falling edge of the 7th clock cycle plus internal propagation delay (Figure 7). Note the PCLK switches on the falling edge of CLK.

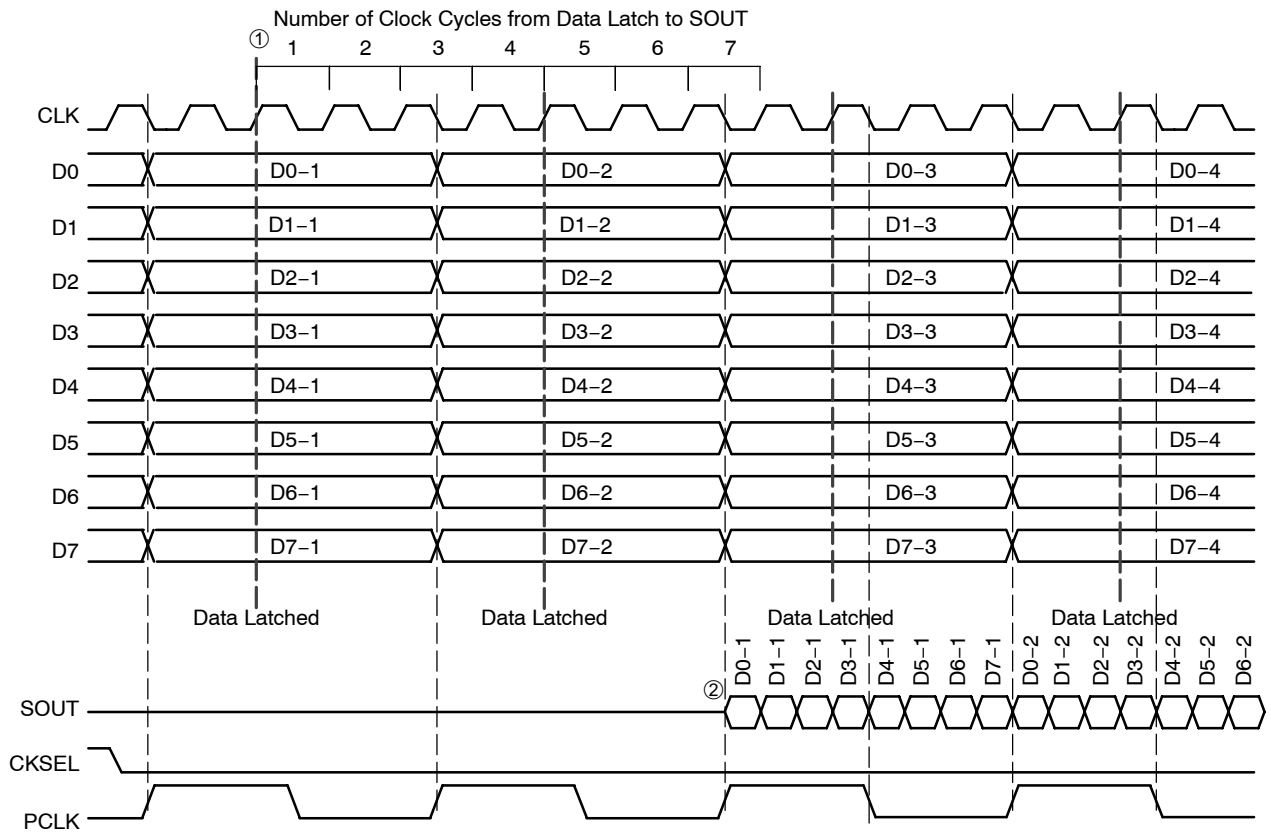

Figure 7. Timing Diagram 1:8 Parallel to Serial Conversion with CKSEL LOW

MC10EP446, MC100EP446

Similarly, for CKSEL HIGH operation, the time from when the parallel data is latched ① to when the data is seen on the S_{OUT} ② is on the rising edge of the 14th clock cycle plus internal propagation delay (Figure 8). Furthermore, the PCLK switches on the rising edge of CLK.

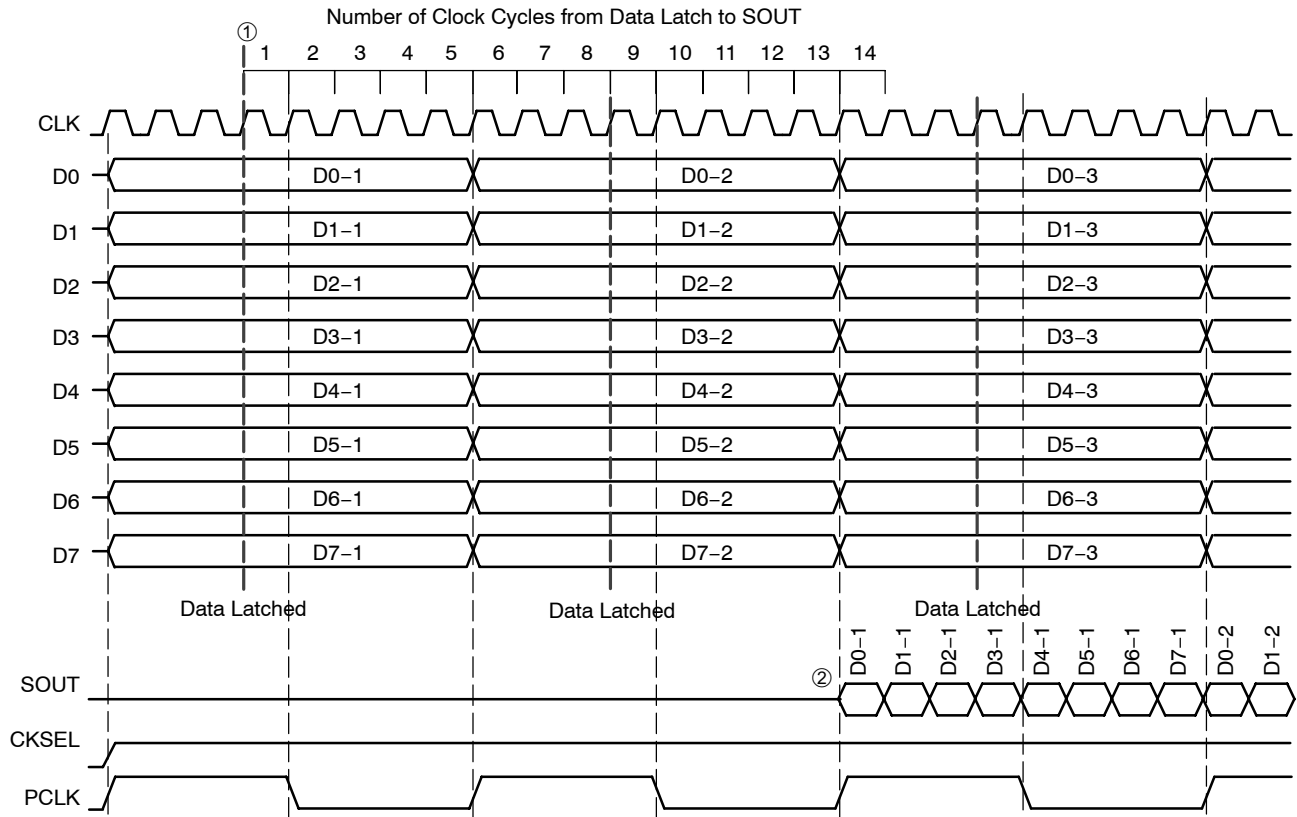

Figure 8. Timing Diagram 1:8 Parallel to Serial Conversion with CKSEL HIGH

MC10EP446, MC100EP446

The device also features a differential SYNC input (Pins 29 and 30), which asynchronously reset all internal flip-flops and clock circuitry on the rising edge of SYNC. The release of SYNC is a synchronous process, which ensures that no runt serial data bits are generated. The falling edge of the SYNC followed by a falling edge of CLK initiates the start of the conversion process on the next rising edge of CLK (Figures 9 and 10). As shown in the figures below, the device will start to latch the parallel input data after the a falling edge of SYNC ①, followed by the falling edge CLK ②, on the next rising of edge of CLK ③ for CKSEL LOW

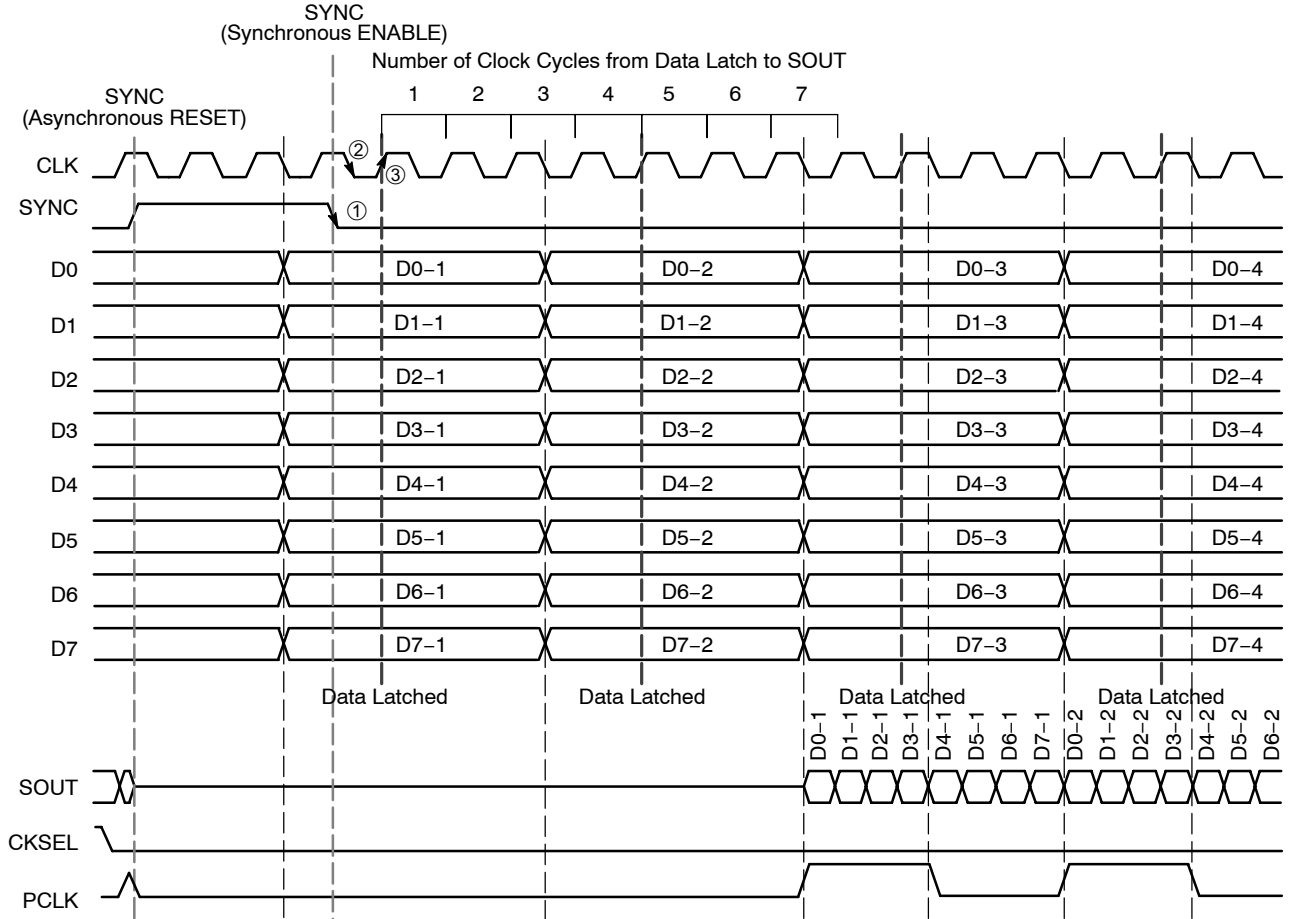

Figure 9. Timing Diagram 1:8 Parallel to Serial Conversion with CKSEL LOW and SYNC

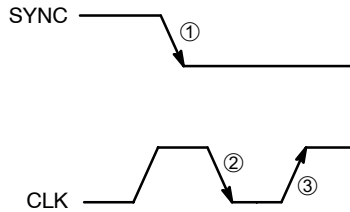

Figure 10. Synchronous Release of SYNC for CKSEL LOW

MC10EP446, MC100EP446

For CKSEL HIGH, as shown in the timing diagrams below, the device will start to latch the parallel input data after the falling edge of SYNC ①, followed by the falling edge CLK ②, on the second rising edge of CLK ③ (Figures 11 and 12).

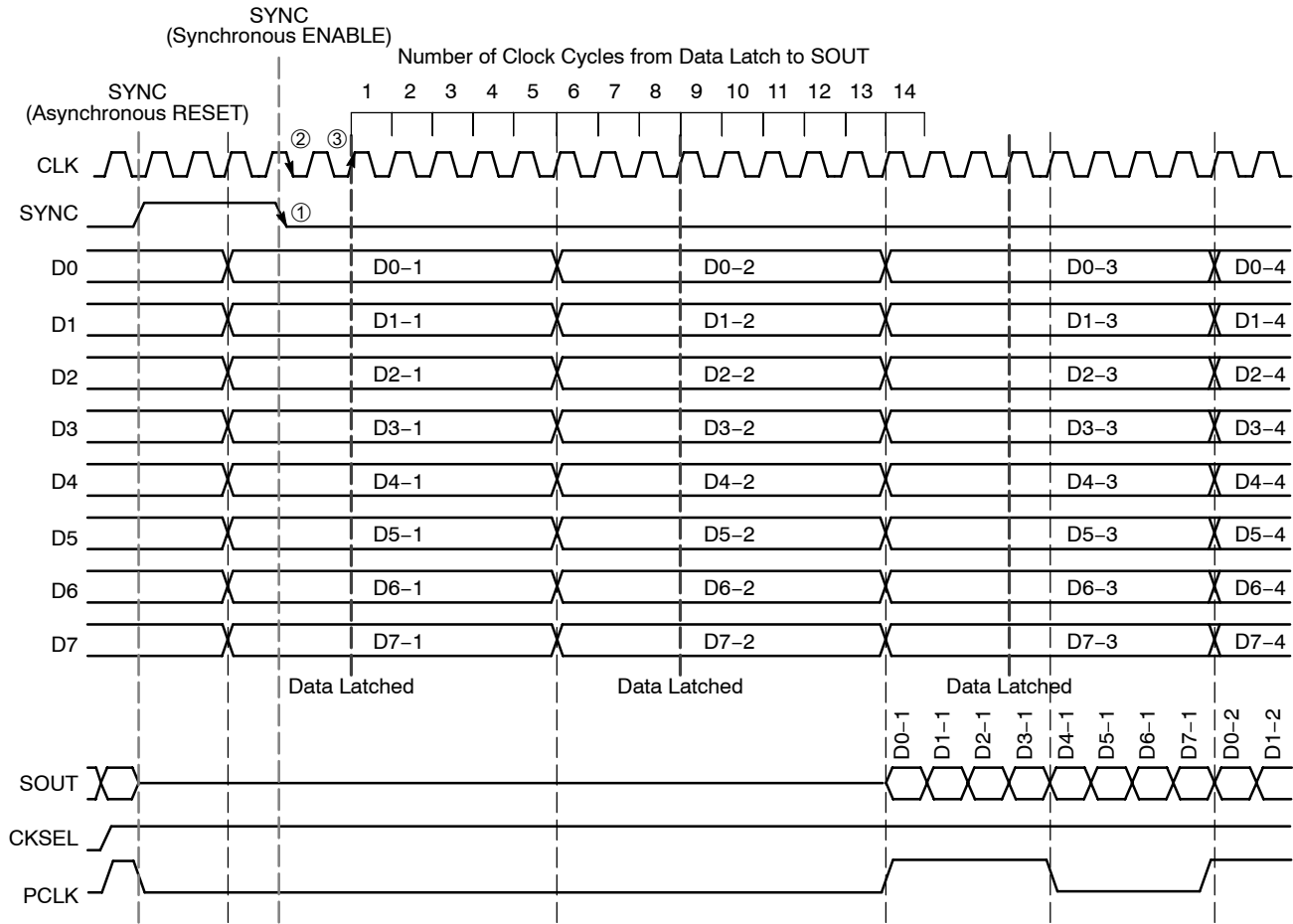

Figure 11. Timing Diagram 1:8 Parallel to Serial Conversion with CKSEL HIGH and SYNC

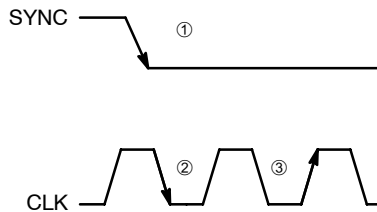

Figure 12. Synchronous Release of SYNC for CKSEL HIGH

MC10EP446, MC100EP446

The differential synchronous CKEN inputs (Pins 6 and 7), disable the internal clock circuitry. The synchronous CKEN will suspend all of the device activities and prevent runt pulses from being generated. The rising edge of CKEN followed by the falling edge of CLK will suspend all activities. The falling edge of CKEN followed by the falling edge of CLK will resume all activities (Figure 13).

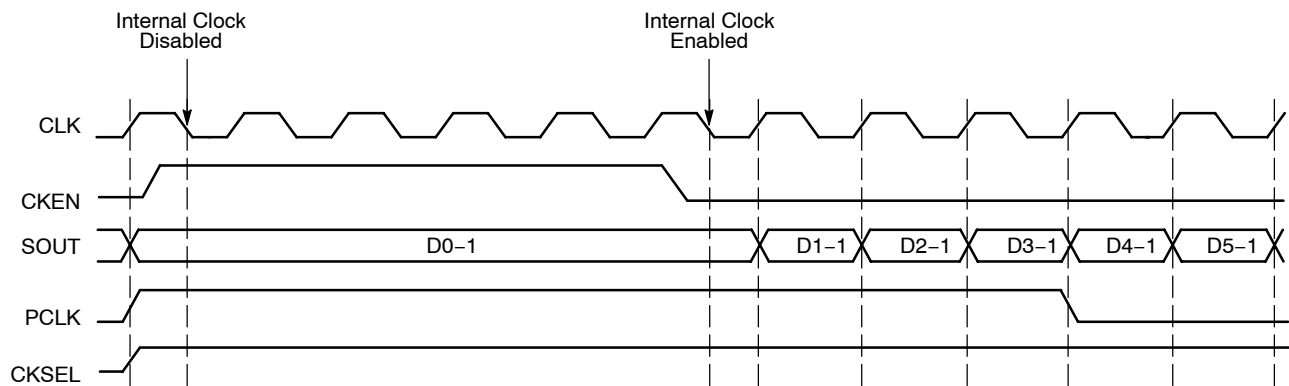

Figure 13. Timing Diagram with CKEN with CKSEL HIGH

The differential PCLK output (Pins 14 and 15) is a word framer and can help the user synchronize the serial data output, S_{OUT} (Pins 11 and 12), in their applications. Furthermore, PCLK can be used as a trigger for input parallel data (Figure 14).

An internally generated voltage supply, the V_{BB} pin, is available to this device only. For single-ended input

conditions, the unused differential input is connected to V_{BB} as a switching reference voltage. V_{BB} may also rebias AC coupled inputs. When used, decouple V_{BB} and V_{CC} via a 0.01 μF capacitor and limit current sourcing or sinking to 0.5 mA. When not used, V_{BB} should be left open. Also, both outputs of the differential pair must be terminated (50 Ω to V_{TT}) even if only one output is used.

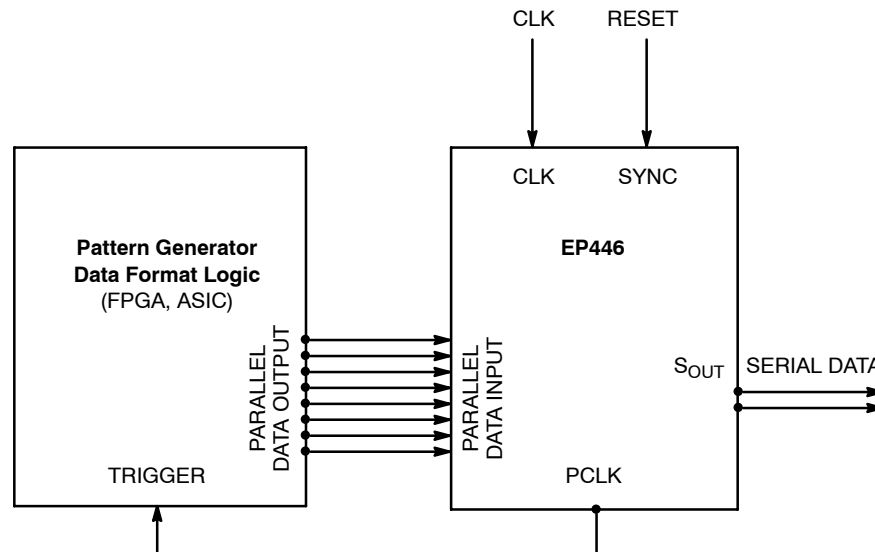

Figure 14. PCLK as Trigger Application

MC10EP446, MC100EP446

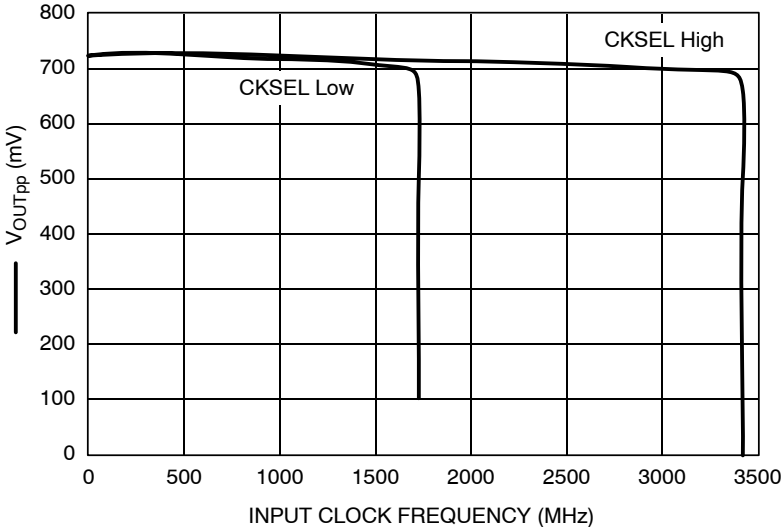

Figure 15. Typical V_{OUTpp} versus Input Clock Frequency, 25°C

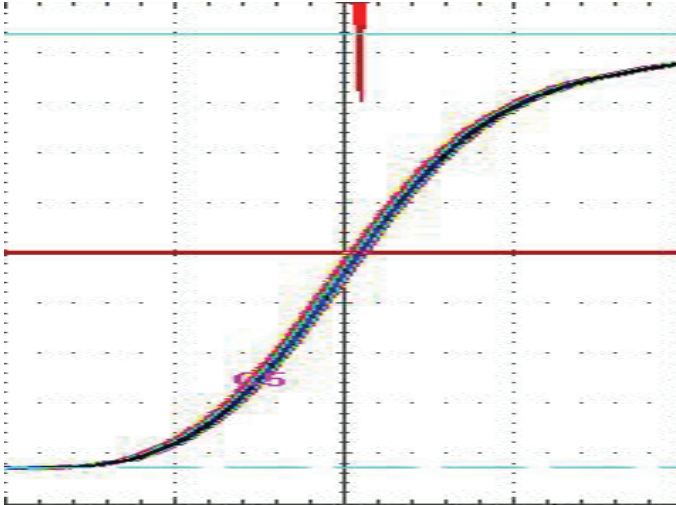
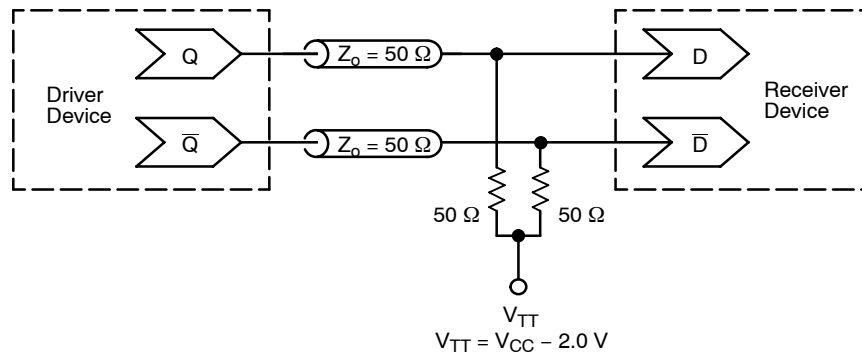

Figure 16. SOUT System Jitter Measurement
(Condition: 3.4 GHz input frequency, CKSEL HIGH, BEOFE32 bit pattern on SOUT)

MC10EP446, MC100EP446



**Figure 17. Typical Termination for Output Driver and Device Evaluation
(See Application Note AND8020/D – Termination of ECL Logic Devices.)**

ORDERING INFORMATION

Device	Package	Shipping [†]
MC10EP446FA	LQFP-32	250 Units / Tray
MC10EP446FAG	LQFP-32 (Pb-Free)	250 Units / Tray
MC10EP446FAR2	LQFP-32	2000 / Tape & Reel
MC10EP446FAR2G	LQFP-32 (Pb-Free)	2000 / Tape & Reel
MC100EP446FA	LQFP-32	250 Units / Tray
MC100EP446FAG	LQFP-32 (Pb-Free)	250 Units / Tray
MC100EP446FAR2	LQFP-32	2000 / Tape & Reel
MC100EP446FAR2G	LQFP-32 (Pb-Free)	2000 / Tape & Reel
MC10EP446MNG	QFN-32 (Pb-Free)	74 Units / Rail
MC100EP446MNG	QFN-32 (Pb-Free)	74 Units / Rail
MC10EP446MNR4G	QFN-32 (Pb-Free)	1000 / Tape & Reel
MC100EP446MNR4G	QFN-32 (Pb-Free)	1000 / Tape & Reel

[†]For information on tape and reel specifications, including part orientation and tape sizes, please refer to our Tape and Reel Packaging Specifications Brochure, BRD8011/D.

Resource Reference of Application Notes

- AN1405/D** – ECL Clock Distribution Techniques
- AN1406/D** – Designing with PECL (ECL at +5.0 V)
- AN1503/D** – ECLinPS™ I/O SPiCE Modeling Kit
- AN1504/D** – Metastability and the ECLinPS Family
- AN1568/D** – Interfacing Between LVDS and ECL
- AN1672/D** – The ECL Translator Guide
- AND8001/D** – Odd Number Counters Design
- AND8002/D** – Marking and Date Codes
- AND8020/D** – Termination of ECL Logic Devices
- AND8066/D** – Interfacing with ECLinPS
- AND8090/D** – AC Characteristics of ECL Devices

MC10EP446, MC100EP446

PACKAGE DIMENSIONS

32 LEAD LQFP
CASE 873A-02
ISSUE C

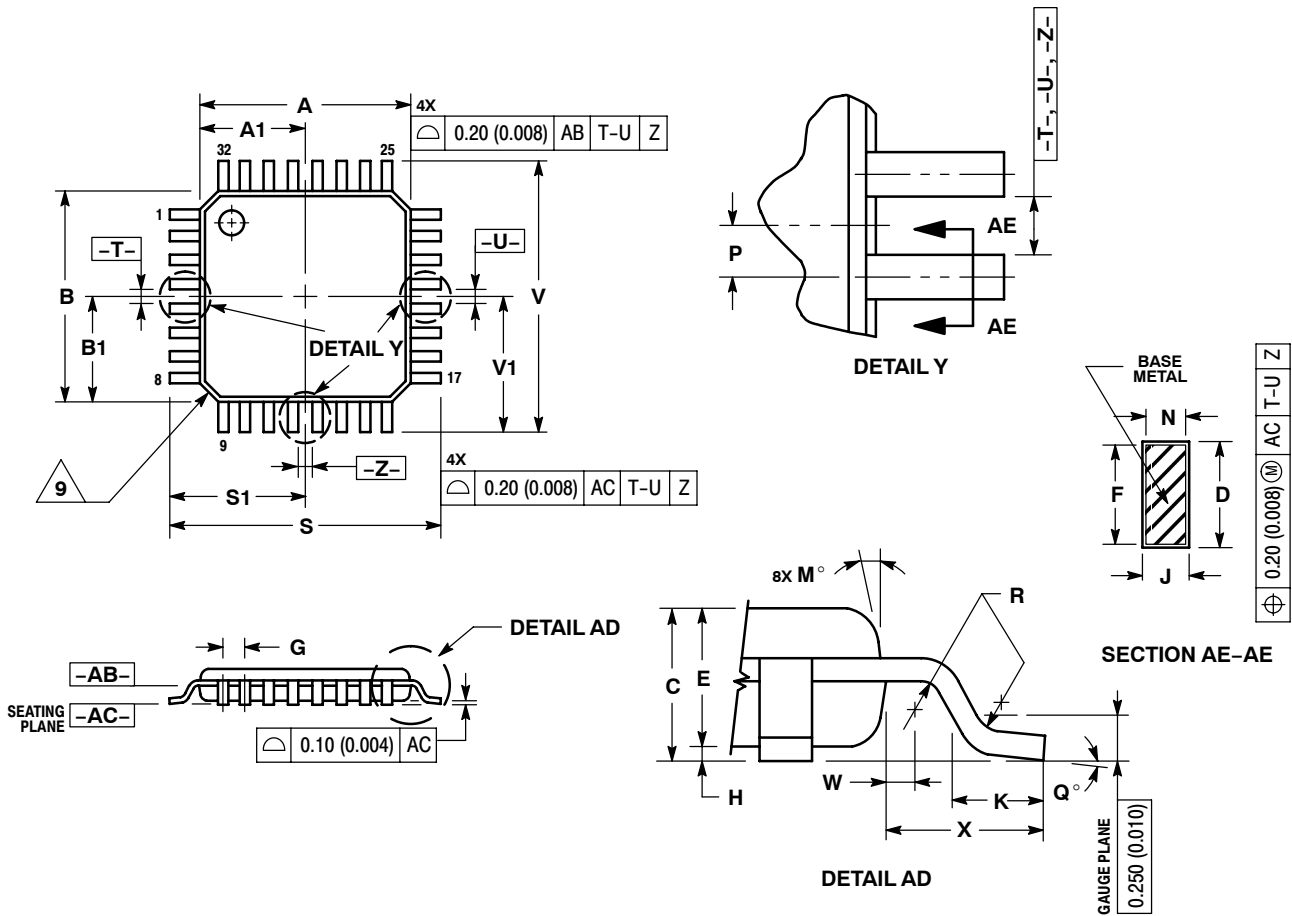

NOTES:

- DIMENSIONING AND TOLERANCING PER ANSI Y14.5M, 1982.
- CONTROLLING DIMENSION: MILLIMETER.
- DATUM PLANE -AB- IS LOCATED AT BOTTOM OF LEAD AND IS COINCIDENT WITH THE LEAD WHERE THE LEAD EXITS THE PLASTIC BODY AT THE BOTTOM OF THE PARTING LINE.
- DATUMS -T-, -U-, AND -Z- TO BE DETERMINED AT DATUM PLANE -AB-.
- DIMENSIONS S AND V TO BE DETERMINED AT SEATING PLANE -AC-.
- DIMENSIONS A AND B DO NOT INCLUDE MOLD PROTRUSION. ALLOWABLE PROTRUSION IS 0.250 (0.010) PER SIDE. DIMENSIONS A AND B DO NOT INCLUDE MOLD MISMATCH AND ARE DETERMINED AT DATUM PLANE -AB-.
- DIMENSION D DOES NOT INCLUDE DAMBAR PROTRUSION. DAMBAR PROTRUSION SHALL NOT CAUSE THE D DIMENSION TO EXCEED 0.520 (0.020).
- MINIMUM SOLDER PLATE THICKNESS SHALL BE 0.0076 (0.0003).
- EXACT SHAPE OF EACH CORNER MAY VARY FROM DEPICTION.

DIM	MILLIMETERS		INCHES	
	MIN	MAX	MIN	MAX
A	7.000	BSC	0.276	BSC
A1	3.500	BSC	0.138	BSC
B	7.000	BSC	0.276	BSC
B1	3.500	BSC	0.138	BSC
C	1.400	1.600	0.055	0.063
D	0.300	0.450	0.012	0.018
E	1.350	1.450	0.053	0.057
F	0.300	0.400	0.012	0.016
G	0.800	BSC	0.031	BSC
H	0.050	0.150	0.002	0.006
J	0.090	0.200	0.004	0.008
K	0.450	0.750	0.018	0.030
M	12°	REF	12°	REF
N	0.090	0.160	0.004	0.006
P	0.400	BSC	0.016	BSC
Q	1°	5°	1°	5°
R	0.150	0.250	0.006	0.010
S	9.000	BSC	0.354	BSC
S1	4.500	BSC	0.177	BSC
V	9.000	BSC	0.354	BSC
V1	4.500	BSC	0.177	BSC
W	0.200	REF	0.008	REF
X	1.000	REF	0.039	REF

MC10EP446, MC100EP446

PACKAGE DIMENSIONS

QFN32 5*5*1 0.5 P
CASE 488AM-01
ISSUE O

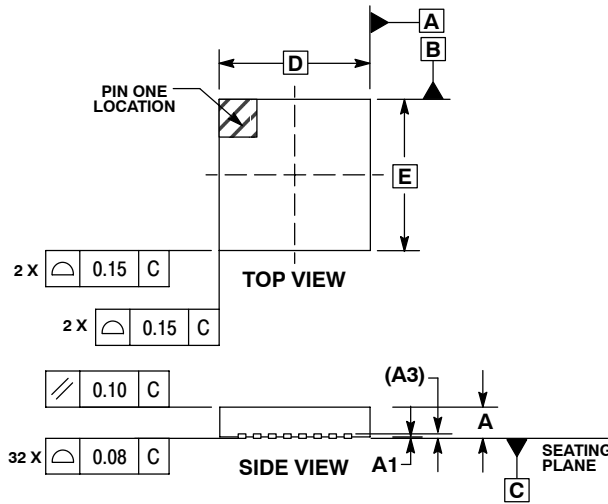

NOTES:

1. DIMENSIONS AND TOLERANCING PER ASME Y14.5M, 1994.
2. CONTROLLING DIMENSION: MILLIMETERS.
3. DIMENSION b APPLIES TO PLATED TERMINAL AND IS MEASURED BETWEEN 0.25 AND 0.30 MM TERMINAL
4. COPLANARITY APPLIES TO THE EXPOSED PAD AS WELL AS THE TERMINALS.

MILLIMETERS			
DIM	MIN	NOM	MAX
A	0.800	0.900	1.000
A1	0.000	0.025	0.050
A3	0.200 REF		
b	0.180	0.250	0.300
D	5.00 BSC		
D2	2.950	3.100	3.250
E	5.00 BSC		
E2	2.950	3.100	3.250
e	0.500 BSC		
K	0.200	---	---
L	0.300	0.400	0.500

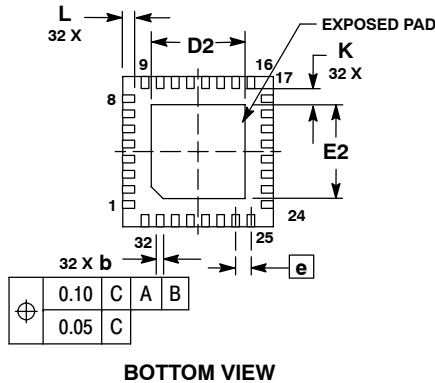

SOLDERING FOOTPRINT*

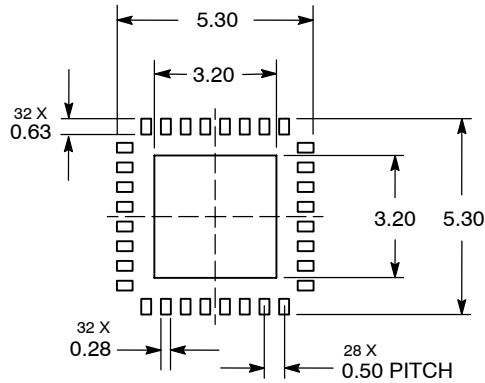

*For additional information on our Pb-Free strategy and soldering details, please download the ON Semiconductor Soldering and Mounting Techniques Reference Manual, SOLDERRM/D.

ECLinPS is a trademark of Semiconductor Components Industries, LLC (SCILLC).

ON Semiconductor and are registered trademarks of Semiconductor Components Industries, LLC (SCILLC). SCILLC reserves the right to make changes without further notice to any products herein. SCILLC makes no warranty, representation or guarantee regarding the suitability of its products for any particular purpose, nor does SCILLC assume any liability arising out of the application or use of any product or circuit, and specifically disclaims any and all liability, including without limitation special, consequential or incidental damages. "Typical" parameters which may be provided in SCILLC data sheets and/or specifications can and do vary in different applications and actual performance may vary over time. All operating parameters, including "Typicals" must be validated for each customer application by customer's technical experts. SCILLC does not convey any license under its patent rights nor the rights of others. SCILLC products are not designed, intended, or authorized for use as components in systems intended for surgical implant into the body, or other applications intended to support or sustain life, or for any other application in which the failure of the SCILLC product could create a situation where personal injury or death may occur. Should Buyer purchase or use SCILLC products for any such unintended or unauthorized application, Buyer shall indemnify and hold SCILLC and its officers, employees, subsidiaries, affiliates, and distributors harmless against all claims, costs, damages, and expenses, and reasonable attorney fees arising out of, directly or indirectly, any claim of personal injury or death associated with such unintended or unauthorized use, even if such claim alleges that SCILLC was negligent regarding the design or manufacture of the part. SCILLC is an Equal Opportunity/Affirmative Action Employer. This literature is subject to all applicable copyright laws and is not for resale in any manner.

PUBLICATION ORDERING INFORMATION

LITERATURE FULFILLMENT:
Literature Distribution Center for ON Semiconductor
P.O. Box 5163, Denver, Colorado 80217 USA
Phone: 303-675-2175 or 800-344-3860 Toll Free USA/Canada
Fax: 303-675-2176 or 800-344-3867 Toll Free USA/Canada
Email: orderlit@onsemi.com

N. American Technical Support: 800-282-9855 Toll Free USA/Canada
Europe, Middle East and Africa Technical Support:
Phone: 421 33 790 2910
Japan Customer Focus Center
Phone: 81-3-5773-3850

ON Semiconductor Website: www.onsemi.com
Order Literature: <http://www.onsemi.com/orderlit>
For additional information, please contact your local Sales Representative