



MOTOROLA

Advance Information Picture-in-Picture (PIP) Controller

The MC44460 Picture-in-Picture (PIP) controller is a low cost member of a family of high performance PIP controllers and video signal processors for television. It is NTSC compatible and contains all the analog signal processing, control logic and memory necessary to provide for the overlay of a small picture from a second non synchronized source onto the main picture of a television. All control and setup of the MC44460 is via a standard two pin I²C bus interface. The device is fabricated using BICMOS technology. It is available in a 56-pin shrink dip (SDIP) package.

The main features of the MC44460 are:

- Two NTSC CVBS Inputs
- Switchable Main and PIP Video Signals
- Single NTSC CVBS Output Allows Simple TV Chassis Integration
- Two PIP Sizes; 1/16 and 1/9 Screen Area
- Freeze Field Feature
- Variable PIP Position in 64-X by 64-Y Steps
- PIP Border with Programmable Color
- Programmable PIP Tint and Saturation Control
- Automatic Main to PIP Contrast Balance
- Vertical Filter
- Integrated 64 k Bit DRAM Memory Resulting in Minimal RFI
- Minimal RFI Allows Simple Low Cost Application into TV
- I²C Bus Control – No External Variable Adjustments Needed
- Operates from a Single 5.0 V Supply
- Economical 56-Pin Shrink DIP Package

MC44460

PICTURE-IN-PICTURE (PIP) CONTROLLER

SEMICONDUCTOR TECHNICAL DATA

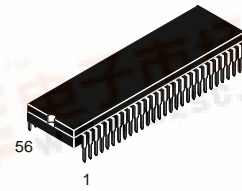

B SUFFIX
PLASTIC PACKAGE
CASE 859
(SDIP)

ORDERING INFORMATION

Device	Operating Temperature Range	Package
MC44460B	T _J = -65° to +150°C	SDIP

Representative Block Diagram

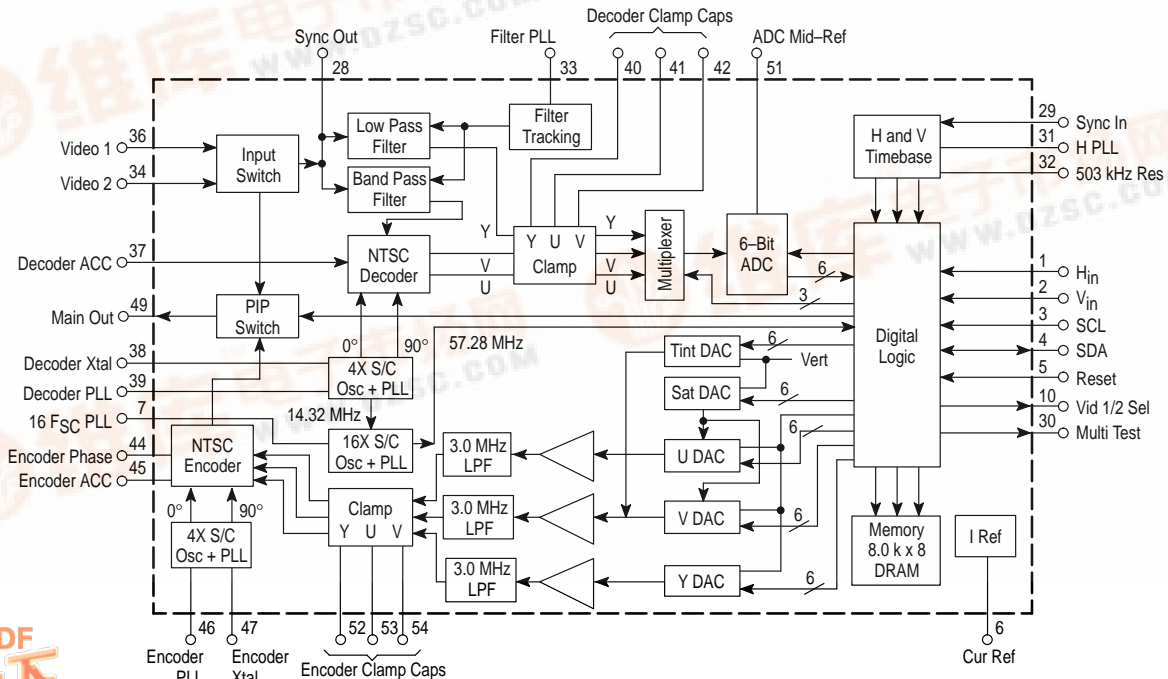

This device contains 500,000 active transistors.

MC44460

PIN CONNECTIONS

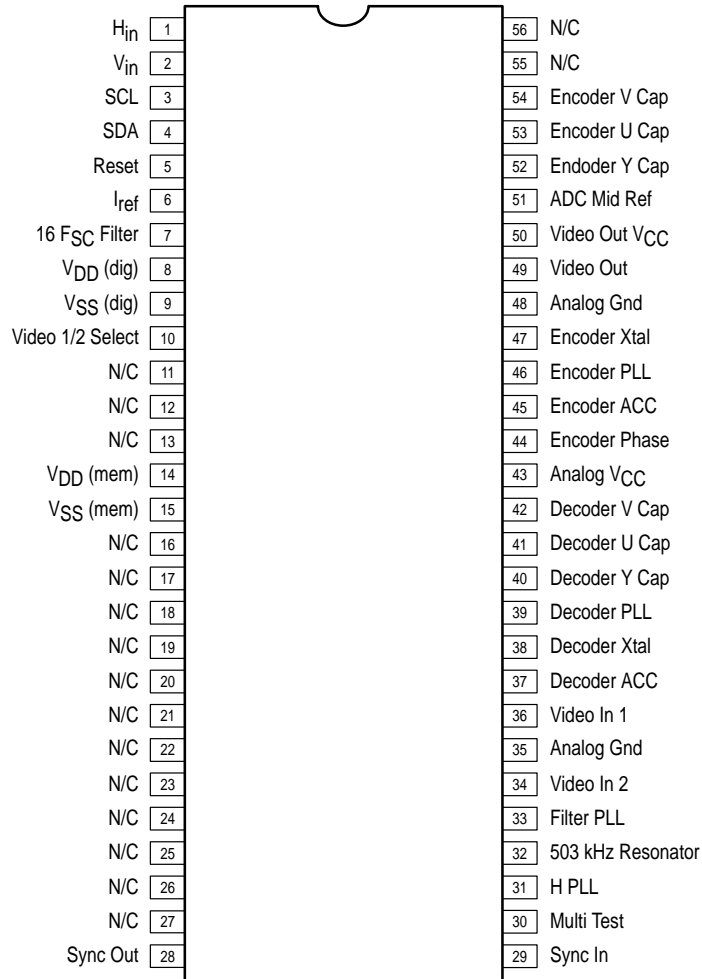

(Top View)

MC44460

MAXIMUM RATINGS

Rating	Symbol	Value	Unit
Power Supply Voltage	V_{DD}	-0.5 to +6.0	V
Power Supply Voltage	V_{CC}	-0.5 to +6.0	V
Input Voltage Range	V_{IR}	-0.5, $V_{DD} + 0.5$	V
Output Current	I_O	160	mA
Power Dissipation Maximum Power Dissipation @ 70°C Thermal Resistance, Junction-to-Air	P_D $R_{\theta JA}$	1.3 59	W °C/W
Junction Temperature (Storage and Operating)	T_J	-65 to +150	°C

NOTE: ESD data available upon request.

ELECTRICAL CHARACTERISTICS ($V_{CC} = V_{DD} = 5.0$ V, $T_A = 25^\circ\text{C}$, unless otherwise noted.)

Characteristic	Symbol	Min	Typ	Max	Unit
----------------	--------	-----	-----	-----	------

POWER SUPPLY

Total Supply (Pins 8, 15, 43 and 50)	Total I_{Supply}	95	124	160	mA
--------------------------------------	--------------------	----	-----	-----	----

VIDEO

Composite Video Input (Pin 34 or 36)	CV_i	-	1.0	-	V _{pp}
Composite Video Output (Pin 49, Unterminated)	-	-	2.0	-	V _{pp}
Video Output DC Level (Sync Tip)	-	-	1.0	-	V _{dc}
Video Gain	-	-	6.0	-	dB
Video Frequency Response (Main Video to -1.0 dB)	-	-	10	-	MHz
Color Bar Accuracy	-	-	±4.0	-	deg
Video Crosstalk (@ 75% Color Bars)	-	-	-	-	dB
Main to PIP	-	-	55	-	
PIP to Main	-	-	55	-	
Output Impedance	-	-	-	5.0	Ω

HORIZONTAL TIMEBASE

Free Run HPLL Frequency (Pin 16)	-	-	15734	-	Hz
HPLL Pull-In Range	-	-	±400	-	Hz
HPLL Jitter	-	-	±4.0	-	ns
Burst Gate Timing (from Trailing Edge Hsync, Pin 24)	-	-	1.0	-	μs
Burst Gate Width	-	-	4.0	-	μs

VERTICAL TIMEBASE

Vertical Countdown Window	-	232	-	296	H lines
Vertical Sync Integration Time	-	-	-	31	μs

ANALOG TO DIGITAL CONVERTER

Resolution	-	-	-	6.0	Bits
Integral Non-Linearity	-	-	±1.0	-	LSB
Differential Non-Linearity	-	-	+2.0/-1.0	-	LSB
ADC - Y Frequency Response @ -5.0 dB	-	-	1.0	-	MHz
ADC - U, V Frequency Response @ -5.0 dB	-	-	200	-	kHz
Sample Clock Frequency (4/3 F _{SC})	-	-	4.773	-	MHz

MC44460

ELECTRICAL CHARACTERISTICS (continued) ($V_{CC} = V_{DD} = 5.0\text{ V}$, $T_A = 25^\circ\text{C}$, unless otherwise noted.)

Characteristic	Symbol	Min	Typ	Max	Unit
DIGITAL TO ANALOG CONVERTER					
Resolution	–	–	–	6.0	Bits
Integral Non-Linearity	–	–	±1.0	–	LSB
Differential Non-Linearity	–	–	+2.0/–1.0	–	LSB
Tint DAC Control Range (in 64 Steps)	–	–10	–	10	Deg
Saturation DAC Control Range (in 64 steps)	–	–6.0	–	6.0	dB
NTSC DECODER					
Color Kill Threshold	–	–24	–	–16	dB
Threshold Hysteresis	–	2.0	3.0	4.0	dB
ACC (Chroma Amplitude Change, +3.0 dB to –12 dB)	–	–0.5	–	0.5	dB
PIP CHARACTERISTICS					
PIP Size	–	–	–	–	–
1/9 Screen Horizontal	–	–	114	–	pels
1/9 Screen Vertical	–	–	71	–	lines
1/16 Screen Horizontal	–	–	84	–	pels
1/16 Screen Vertical	–	–	54	–	lines
Border Size Horizontal	–	–	6.0	–	pels
Border Size Vertical	–	–	2.0	–	lines
Output PEL Clock (4 F _{SC})	–	–	14.318	–	MHz
Position Control Range Horizontal (% of Main Picture)	–	–	100	–	%
Position Control Range Vertical (% of Main Picture)	–	–	100	–	%

MC44460

PIN FUNCTION DESCRIPTION

Pin	Equivalent Internal Circuit	Description
1		Horizontal Reference In (H_{in}) CMOS level pulse synchronous with TV horizontal retrace signal. This pulse may be active high or low since there is a polarity selector bit in an internal control register. <i>This pulse should begin 0.5 to 0.75 μs after the beginning of the main video H sync period.</i> Its duty cycle should be less than 50%.
2		Vertical Reference In (V_{in}) CMOS level pulse synchronous with TV vertical retrace signal. This pulse may be active high or low since there is a polarity selector bit in an internal control register. This pulse should begin during the main video vertical interval and have a duration of at least .5H.
3		Serial Clock (SCL) CMOS level I ² C Compatible slave only clock input. 100 kHz Maximum frequency. 50% duty cycle. See Figure 1 for timing. See I ² C Register Description for internal register descriptions and addresses.
4		Serial Data (SDA) CMOS level I ² C Compatible slave only data input/output. As an output it is open collector. See Figure 1 for timing. See I ² C Register Description for internal register descriptions and addresses.
5		Reset The active low, Power On Reset initializes all internal registers to zero and resets the I ² C interface. Minimum active low time required for Power On Reset reset is 100 ms.
6		Current Reference The internal reference for all analog circuitry should be connected to an external 12.1 k resistor.
7		PLL Filter Filter for the 16X S/C PLL which is phase locked to the 4X S/C oscillator.

Pins 11 to 13, 16 to 27, 55 and 56 are test pins configured as outputs in a high impedance state. In an application, no connection should be made to these pins.

MC44460

PIN FUNCTION DESCRIPTION (continued)

Pin	Equivalent Internal Circuit	Description
8 14, 43, 50 9 15, 35, 48		V_{DD}, V_{SS} The four V _{DD} pins must be externally connected to a 5.0 V (±5%) supply. The four V _{SS} lines must externally connect to their respective V _{DD} bypass return(s) to ensure that no ground disturbances occur in operation. All supplies must be properly bypassed and isolated for the application. Bypass capacitors of 10 μF in parallel with 0.1 μF for each supply are recommended as a general guideline. The 0.1 μF, high frequency bypass capacitors should be placed as close to the power pins as practical.
10		Video 1/2 Select Output High output level indicates that Video 1 is selected to be the main picture video. Low output level indicates Video 2 is selected to be the main picture video.
28		Sync Out Outputs the video signal selected as the PIP to be filtered and applied to the H and V timebase through the Sync In pin.
29		Sync In PIP sync pulses are externally filtered and applied to the H and V timebase to allow H and V synchronization.
30		Multi Test Under control of I ² C bus output signals for test and adjustment are provided through this pin.
31		H PLL Connection for horizontal timebase PLL filter. See separate discussion for filter values.

Pins 11 to 13, 16 to 27, 55 and 56 are test pins configured as outputs in a high impedance state. In an application, no connection should be made to these pins.

MC44460

PIN FUNCTION DESCRIPTION (continued)

Pin	Equivalent Internal Circuit	Description
32		<p>503 kHz Resonator Single pin oscillator is used as the main timebase reference. It is phase locked to the PIP H sync pulses. This oscillator provides the reference to the system logic, PIP decoder and vertical timebase circuitry.</p>
33		<p>Filter PLL The on board reference filter produces a phase shift which is measured and applied to an internal filter PLL. This capacitor connected to this pin stores the phase correction voltage for the PLL which sets the 90° phase correction reference for the rest of the on chip filters.</p>
36 and 34		<p>Video Input 1 and 2 Accepts ac coupled 1.0 Vpp composite video input usually from a source generated inside the TV and an external video source. The series coupling capacitor also functions as the storage capacitor for the clamp voltage for the input circuit. It is necessary to return the input of this capacitor to ground through a dc low impedance to enable this clamp function. R = 50 to 100 Ω is acceptable.</p>
37		<p>Decoder ACC The Decoder ACC pin provides access to the internal chroma decoder automatic gain control amplifier. The ACC capacitor filters the feedback loop of this amplifier. During PIP burst gate time a voltage proportional to the burst gate magnitude is stored on the capacitor connected to this pin to compensate for input chroma level variation and provide a constant U and V output level to the A/D conversion stage.</p>
38		<p>Decoder Crystal 4X Sub-Carrier crystal used to synchronize the decoding of the PIP UV information prior to A/D conversion, sub-sampling and storage in the field memory. The crystal frequency is 14.31818 MHz.</p>

Pins 11 to 13, 16 to 27, 55 and 56 are test pins configured as outputs in a high impedance state. In an application, no connection should be made to these pins.

MC44460

PIN FUNCTION DESCRIPTION (continued)

Pin	Equivalent Internal Circuit	Description
39		Decoder PLL Connection for Decoder PLL filter. See separate discussion for filter values.
44		Encoder Phase Phase difference of the main to encoded burst is sampled and applied to the capacitor connected to this pin to shift the phase of the re-encoded chrominance to match the main.
45		Encoder ACC The Encoder ACC pin provides access to the internal chroma reference sample and hold circuit, which stores the sampled value of the main channel chroma burst amplitude on this external ACC capacitor. The ACC amplifier matches the chroma amplitude of the insert picture to that of the main picture.
46		Encoder PLL Connection for Encoder PLL filter. See separate discussion for filter values.
47		Encoder Crystal 4X Sub-Carrier crystal used to synchronize the encoding of the PIP YUV from the field memory with the main video. The output from this PLL is phase corrected to match the PIP video signal to the main video at the PIP switch. The crystal frequency is 14.31818 MHz.

Pins 11 to 13, 16 to 27, 55 and 56 are test pins configured as outputs in a high impedance state. In an application, no connection should be made to these pins.

MC44460

PIN FUNCTION DESCRIPTION (continued)

Pin	Equivalent Internal Circuit	Description
49		<p>Video Out</p> <p>The selected Video 1/2 input is available at the Video Out mixed with the PIP overlay when selected. This signal is a nominal 2.0 V peak-to-peak signal unterminated. This connection is intended to drive an external series 75 Ω load into a 75 Ω termination to ground to provide a 1.0 Vpp signal at the termination.</p>
51		<p>ADC Mid Reference</p> <p>The mid-point of the A/D converter reference divider network is brought out on this pin in order to add a filter capacitor to remove any noise in the network.</p>
54, 53, 52, 42, 41, 40		<p>Encoder and Decoder YUV Caps</p> <p>During the internal H rate clamping time the YUV reference levels are set by the charge on the capacitors attached to these pins. The nominal value of these capacitors should be 0.01 μF.</p>

Pins 11 to 13, 16 to 27, 55 and 56 are test pins configured as outputs in a high impedance state. In an application, no connection should be made to these pins.

Figure 1. I²C Data Transfer

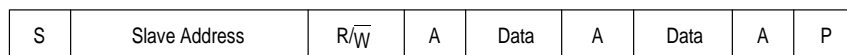
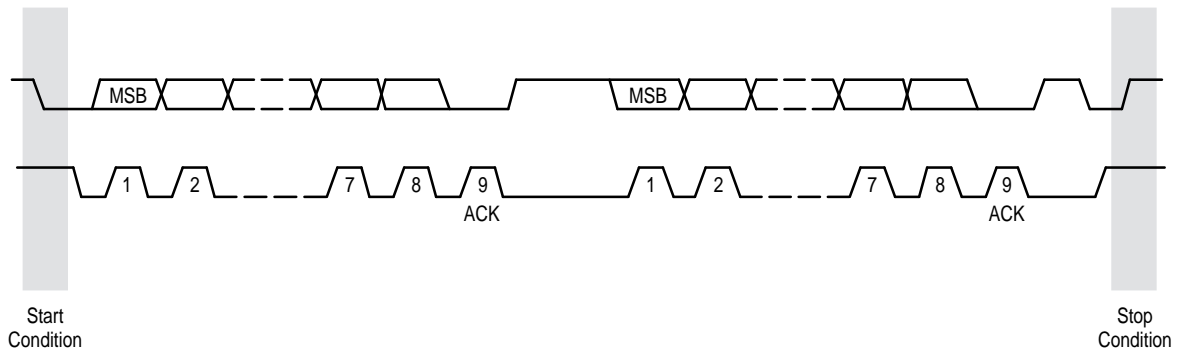

A = Acknowledge
S = Start
P = Stop

Data Transferred
(n Bytes + Acknowledge)

MC44460

I²C REGISTER DESCRIPTIONS

Base read address = 24h

Base write address = 25h

Read Register

There are two active bits in the single read byte available from the MC44460 as follows:

Write Vertical Indicator (WVIO) – D7

When 0 indicates that the write operation specified by the last I²C command has been completed.

PIP Sync Detect Bit (PSD0) – D1

When 0 indicates that the PIP video H pulses are present and the horizontal timebase oscillator is within acceptable limits.

Write Registers

Read Start Position/Write Start Position Registers

Sub-address = 00h

Write Raster Position Start Bits (WPS0–2) – D0–D2

Establishes the horizontal beginning of the PIP and its black level measurement gate. This beginning may be varied by approximately 3.0 μs. The position of this pulse may be observed through the Multi Test Pin 30 (See Test Mode Register Sub-address 03h).

Read Raster Position Bits (RPS0–3) – D4–D7

Establishes the clamp gate position for the black level reference for the main picture. This position may be varied by approximately 5.0 μs. The position of this pulse may be observed through the Multi Test Pin 30 (See Test Mode Register Sub-address 03h).

Pip Switch Delay/Vertical Filter Register

Sub-address = 01h

PIP Switch Delay Bits (PSD0–3) – D0–D3

Delays the start of PIP on time relative to the PIP picture. These bits are used to center the PIP border and PIP picture in the horizontal direction.

Vertical Filter Bit (VFON) – D4

When the filter is activated (VFON = 1) a three line weighted average is taken to provide the data stored in the field memory.

Border Color Register

Sub-address = 02h

Border Color Bits (BC0–2) – D0–D2

These Bits control the color of the border. Note that when using one of the saturated border colors it is possible to get objectionable dot crawl at the edge of the border in some TVs unless appropriate comb filtering is used in the TV circuitry.

BC (2:0)	Border Color
000	Black
001	White 70%
010	No Border (clear)
011	No Border (clear)
100	Blue
101	Green
110	Red
111	White

Test Mode/Main Vertical and Horizontal Polarity Register

Sub-address = 03h

Internal Test Mode Register (ITM0–2) – D0–D2

Sets the Multi Test Pin output to provide one of several internal signals for test and production alignment. Also controls the test memory address counter.

ITM (2:0)	Multi-Test I/O and Function
000	Input – Analog Test mode
001	Input – Digital Test mode
010	Output – Multi Sync Detect
011	Output – Multi PIP Switch
100	Output – Multi PIP H Detect
101	Output – Multi PIP V Detect
110	Output – Multi PIP Clamp
111	Output – Multi Main Clamp

Main vertical polarity select bit (MVP0) – D6

Selects polarity of active level of vertical reference input. 0 = positive going, 1 = negative going.

Main horizontal polarity select bit (MHP0) – D7

Selects polarity of active level of horizontal reference input. 0 = positive going, 1 = negative going.

PIP Freeze/PIP Size/Main and PIP Video Source Register

Sub-address = 04h

PIP Freeze Bit (STILO) – D4

When set to one, the most recently received field is continuously displayed until the freeze bit is cleared.

PIP Size Bit (PSI90) – D5

Switches the PIP size between 1/16 main size (when 0) and 1/9 main size (when 1).

Main Video Source Select Bit (MSEL0) – D6

Selects which video input will be applied to the PIP switch as the main video out.

PIP Video Source Select Bit (PSEL0) – D7

Selects which video input will be applied to the video decoder to provide the PIP video.

MSEL/PSEL	Function
0	Video 1 Input to Main/ Video 1 Input to PIP
1	Video 2 Input to Main/ Video 2 Input to PIP

PIP On/PIP Blank Register

Sub-address = 05h

PIP On Bit (PON0) – D0

When on (1) turns the PIP on.

PIP Blanking Bit (PBL0) – D4

When on (1) sets the PIP to black. If the PIP is off, then it will be black if it is turned on. Overrides all other settings of the PIP control.

PIP X Position Register

Sub-address = 06h

X Position Bits (XPS0–5) – D0–D5

Moves the PIP start position from the left to the right edge of the display in 64 steps. There is protection circuitry

MC44460

CIRCUIT DESCRIPTION

The MC44460 Picture-in-Picture (PIP) controller is composed of an analog section, logic section and an 8.0 k x 8-bit DRAM array. A block diagram showing details of all of these sections is shown in the Representative Block Diagram.

The analog section includes an Input Switch, Sync Processor, Filters, PLLs, NTSC Decoder, ADC, DACs, NTSC Encoder and Output Switch. All necessary controls are provided by registers in the logic section. These registers are set by external control through the I²C Bus.

In operation, the MC44460 overlays a single PIP on the main video in either a 1/9th or 1/16th size. In 1/9th, the PIP is 152 samples (114 Y, 19 V, 19 U) by 70 lines and occupies 8094 bytes of the 8192 byte DRAM. The 1/16 size is 112 samples (84 Y, 14 V, 14 U) by 52 lines and occupies 4452 bytes of the DRAM. An extra line of data is stored for each PIP size to allow for interlace disorder correction. The 6:1:1 samples are formatted by the logic section as follows in order to efficiently utilize memory:

Byte 1: Y0(5:0), V(1:0)

Byte 2: Y1(5:0), V(3:2)

Byte 3: Y2(5:0), V(5:4)

Byte 4: Y3(5:0), U(1:0)

Byte 5: Y4(5:0), U(3:2)

Byte 6: Y5(5:0), U(5:4)

Refer to the block diagram. Both the video inputs are applied to an input switch which is controlled by the I²C bus interface. Either of the inputs is applied to the PIP processing circuitry and either to the main video signal path of the output switch. The signal applied to the PIP processor also provides the vertical sync reference to the PIP processor.

The PIP output from the switch is applied to a 1.0 MHz cutoff low pass GmC biquad filter to extract the luminance signal and a similar bandpass filter to pass chroma to the decoder section. These filters are tracked to a master GmC cell using subcarrier as a reference. A single-ended transconductance stage with relatively large signal handling ability (>2.5 V_{pp} @ 4.5 V V_{CC}) is used to avoid potential noise problems.

Figure 2. NTSC Decoder

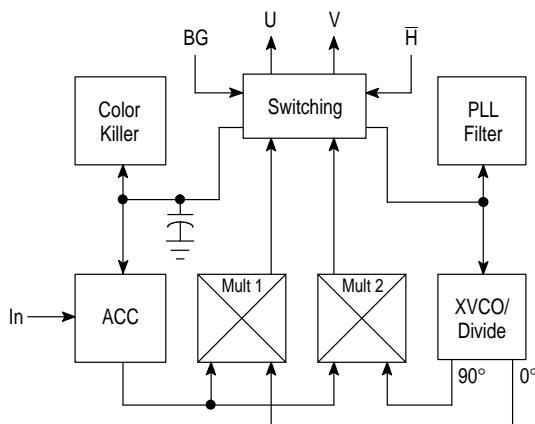

The NTSC Decoder (Figure 2) consists of two multipliers, a voltage controlled 4 X S/C crystal oscillator/divider, Automatic Color Control (ACC) block, Color Kill circuit and necessary switching. During Burst Gate time, the ACC block

in the NTSC Decoder is calibrated with respect to burst magnitude by applying the output of multiplier 1 to the reference input of the ACC block. The result is U and V outputs which are $0.6 V \pm 0.5 \text{ dB}$ for burst amplitudes varying from -12 dB to 3.0 dB. The second multiplier serves as a phase detector during color burst to match the 90 degree output from the XVCO to the 180 degree color burst and feed a correction current to the PLL filter. The phase is correct when the two signals are 90 degrees out of phase.

During the H drive time, the output of the multipliers is fed to the YUV clamp, filtered to 200 KHz and input along with the Y signal to the multiplexer.

The YUV samples are fed through a multiplexer to a single six bit A/D converter. The A/D is a flash type architecture and is capable of digitizing at a 20 MHz sample rate. It is comprised of an internal bandgap source voltage reference, a 64 tap resistor ladder comparator array, a binary encoder and output latches. Once the multiplexer has switched, sufficient time is provided to allow the A/D converter to settle before the reading is latched. The encoder code is determined from the values of any comparators which are not metastable.

The multiplexer and A/D converter receive and convert the YUV data at a $4F_{SC}/3$ rate for a 1/9th size picture or F_{SC} for a 1/16th size picture. The samples are taken in the following way to simplify the control logic:

Y,V,Y,U,Y,V,Y,U

To provide a 6:1:1 format, one of three U and V samples is saved to memory giving a luminance sample rate of $2F_{SC}/3$ for a 1/9th picture and $F_{SC}/2$ for a 1/16 picture. In the vertical direction, one line of every 3 (1/9th picture) or 4 (1/16th picture) are saved. In order to avoid objectionable artifacts, a piece-wise vertical filter is used to take a weighted average on the luminance samples. For three lines (1/9th size) the weight is $1/4 + 1/2 + 1/4$ and for four lines (1/16 size) it is $1/4 + 1/4 + 1/4 + 1/4$. This filter also delays the luma samples correcting for the longer chroma signal path through the decoder.

Finally the logic incorporates a field generator to determine the current field in order to correct interlace disorders arising from a single field memory.

A separate process runs in the logic section to create the PIP window on the main picture. Control signals are generated and sent to the memory controller to read data from the field memory. Data from the eight bit memory are then de-multiplexed into a six bit YUV format, borders are added, blanking is generated for the video clamps and sent to the Y, U and V DACs. Since the PIP display is based on a data clock, it is important to minimize the main display clock skew on a line by line basis. Skew is minimized in the MC44460 by relocking the display timebase to the nearest rising or falling edge of a $16F_{SC}$ clock. This produces a maximum line to line skew of approximately 8.0 ns which is not perceptible to the viewer. The PIP write logic also incorporates a field generator for use by the memory controller for interlace disorder correction. Interlace disorder can occur when the line order of the two fields of the PIP image is swapped due to a mismatch with the main picture field or due to an incomplete field being displayed from memory. The main and PIP field generators, along with monitoring, when the PIP read address passes the PIP write

MC44460

address, allows the read address to the memory to be modified to correct for interlace disorder.

The read logic can provide various border colors: black, 75% white (light gray), 50% white (medium gray), red, green, blue or transparent (no border). In a system without an adaptive comb filter, borders which contain no chroma give the best results. Also built into the read logic is a PIP fill mode which allows the PIP window to be filled with either a solid green, blue or red color as an aid in aligning the PIP analog color circuitry.

Because the DAC output video will be referenced during back porch time, the read processor zeroes the luminance value and sets the bipolar U and V values to mid-range during periods outside the PIP window to ensure clamping at correct levels. Since the PIP window is positioned relative to the main picture's vertical and horizontal sync, a safety feature turns off the window if the window encroaches upon the sync period, thus preventing erroneous clamping.

The Y, U and V DACs are all three of the same design. A binary weighted current source is used, split into two, three bit levels. In the three most significant bits, the current sources are cascaded to improve the matching to the three least significant current sources. Analog transmission gates, switched by the bi-phase outputs of the data latches, feed the binary currents to the single ended current mirror. The output current is subsequently clamped and filtered for processing by the NTSC Encoder.

The outputs of the U and V DACS are buffered and burst flag pulses added to both signals. The U burst flag is fixed to generate a -180° color burst at the modulator output. The V burst flag is variable under the control of an internal register

set through the I²C bus to provide a variable tint. Saturation is controlled by varying a register which sets the reference voltage to the U and V DACs. This is also under I²C bus control. By oversampling the U and V DACs, it was possible to use identical post-DAC filtering for Y, U and V, thereby reducing the delay inequalities between Y and UV and also simplifying the design. After filtering, the U and V signals are clamped to an internal reference voltage during horizontal blanking periods and fed to the U and V modulators. In the NTSC Decoder, the Y, U and V signals were scaled to use the entire A/D range. Gain through the NTSC Encoder is set to properly match these amplitudes.

The phase of the re-encoded chrominance must match that of the incoming main video signal at the input to the PIP switch, so a separate first order PLL is placed within the loop of the main video signal burst PLL. The first order PLL compares the phase of the main burst with that of the encoded burst and moves the oscillator phase so that they match. A special phase shift circuit allowing a continuous range of 180° was developed to do this.

The amplitude of the re-encoded chrominance signal must also match that of the main video signal. To do this, a synchronous amplitude comparator looks at both burst signals and adjusts the chrominance amplitude in the modulator section of the NTSC encoder. The Y signal from the YDAC is compared to the main video signal at black level during back porch time and clamped to this same black level voltage. The PIP chrominance and luminance are then added together and fed to the PIP output switch through a buffered output.

MC44460

Figure 3. Application Circuit

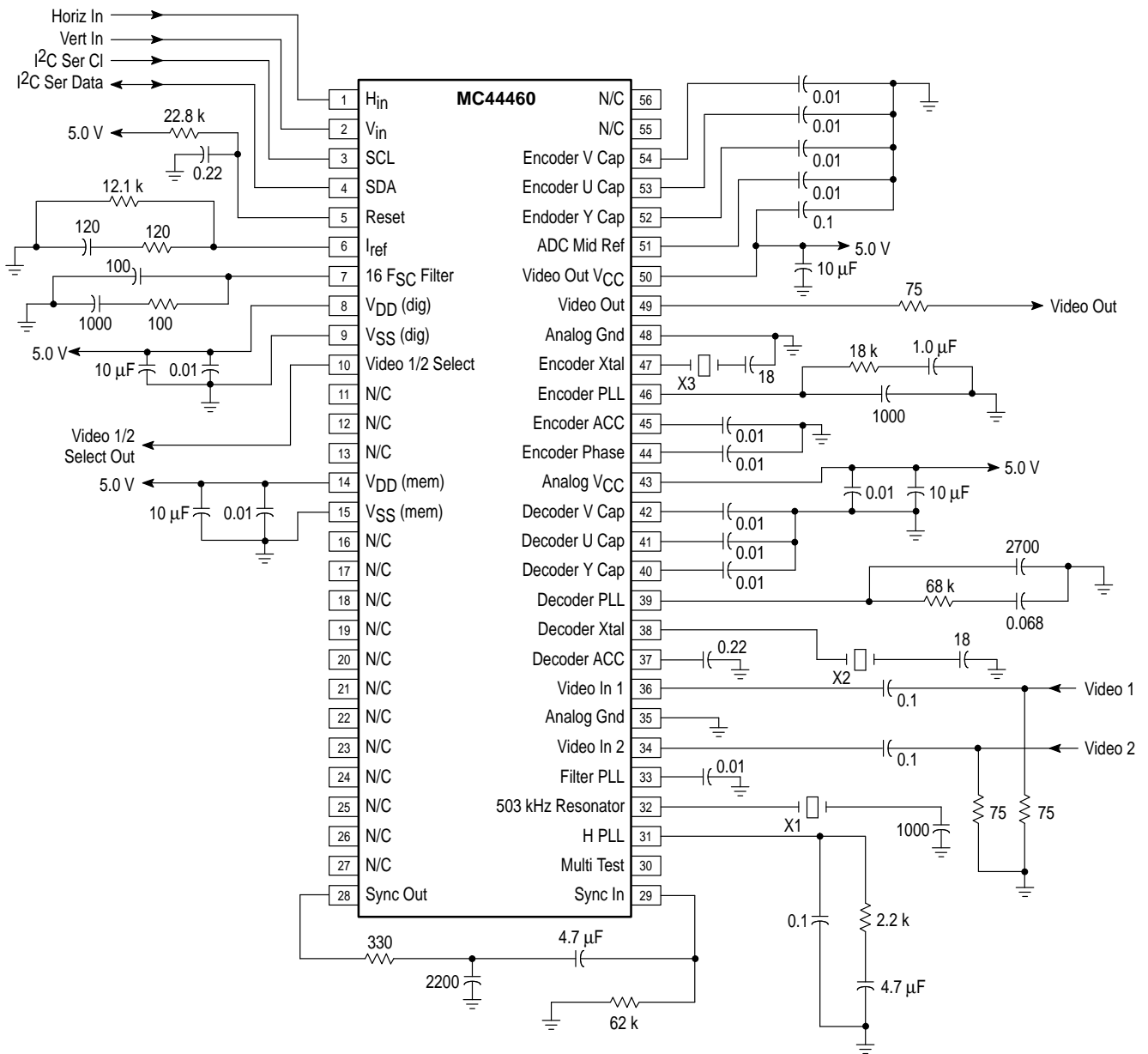

X1 – 503 kHz– Murata Erie CSB503F2 or equivalent
 X2 – 14.31818 MHz – Fox 143–20 or equivalent
 X3 – 14.31818 MHz – Fox 143–20 or equivalent

NOTE: For proper noise isolation, Power Supply Pins 8, 14, 43 and 50 should be bypassed by both high and low frequency capacitors. As a guideline, a 10 μF in parallel with a 0.1 μF at each supply pin is recommended.

MC44460

OUTLINE DIMENSIONS

B SUFFIX
 PLASTIC PACKAGE
 CASE 859-01
 (SDIP)
 ISSUE O

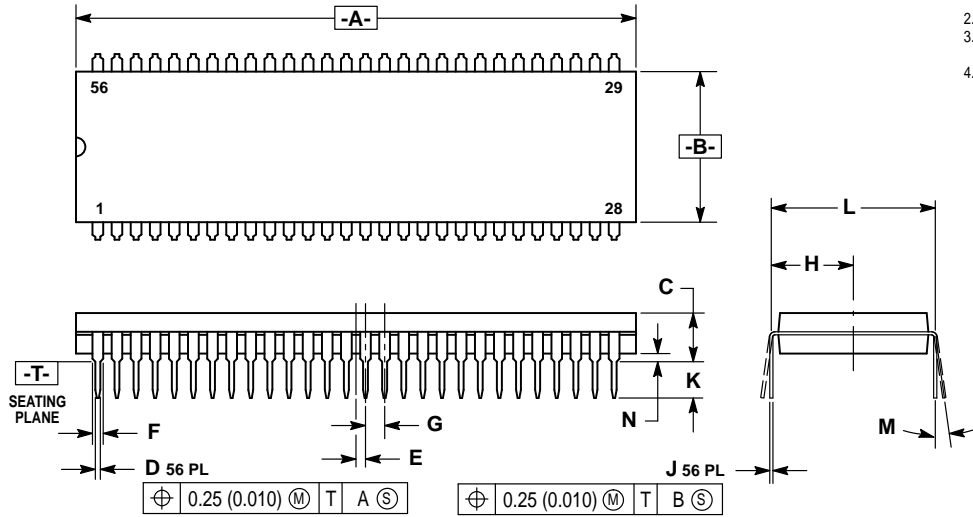

NOTES:

1. DIMENSIONS AND TOLERANCING PER ANSI Y14.5M, 1982.
2. CONTROLLING DIMENSION: INCH.
3. DIMENSION L TO CENTER OF LEAD WHEN FORMED PARALLEL.
4. DIMENSIONS A AND B DO NOT INCLUDE MOLD FLASH. MAXIMUM MOLD FLASH 0.25 (0.010).

DIM	INCHES		MILLIMETERS	
	MIN	MAX	MIN	MAX
A	2.035	2.065	51.69	52.45
B	0.540	0.560	13.72	14.22
C	0.155	0.200	3.94	5.08
D	0.014	0.022	0.36	0.56
E	0.035 BSC		0.89 BSC	
F	0.032	0.046	0.81	1.17
G	0.070 BSC		1.778 BSC	
H	0.300 BSC		7.62 BSC	
J	0.008	0.015	0.20	0.38
K	0.115	0.135	2.92	3.43
L	0.600 BSC		15.24 BSC	
M	0°	15°	0°	15°
N	0.020	0.040	0.51	1.02

MC44460

Motorola reserves the right to make changes without further notice to any products herein. Motorola makes no warranty, representation or guarantee regarding the suitability of its products for any particular purpose, nor does Motorola assume any liability arising out of the application or use of any product or circuit, and specifically disclaims any and all liability, including without limitation consequential or incidental damages. "Typical" parameters can and do vary in different applications. All operating parameters, including "Typicals" must be validated for each customer application by customer's technical experts. Motorola does not convey any license under its patent rights nor the rights of others. Motorola products are not designed, intended, or authorized for use as components in systems intended for surgical implant into the body, or other applications intended to support or sustain life, or for any other application in which the failure of the Motorola product could create a situation where personal injury or death may occur. Should Buyer purchase or use Motorola products for any such unintended or unauthorized application, Buyer shall indemnify and hold Motorola and its officers, employees, subsidiaries, affiliates, and distributors harmless against all claims, costs, damages, and expenses, and reasonable attorney fees arising out of, directly or indirectly, any claim of personal injury or death associated with such unintended or unauthorized use, even if such claim alleges that Motorola was negligent regarding the design or manufacture of the part. Motorola and  are registered trademarks of Motorola, Inc. Motorola, Inc. is an Equal Opportunity/Affirmative Action Employer.

How to reach us:

USA / EUROPE: Motorola Literature Distribution;
P.O. Box 20912; Phoenix, Arizona 85036. 1-800-441-2447

JAPAN: Nippon Motorola Ltd.; Tatsumi-SPD-JLDC, Toshikatsu Otsuki,
6F Seibu-Butsuryu-Center, 3-14-2 Tatsumi Koto-Ku, Tokyo 135, Japan. 03-3521-8315

MFAX: RMFAX0@email.sps.mot.com - TOUCHTONE (602) 244-6609
INTERNET: <http://Design-NET.com>

HONG KONG: Motorola Semiconductors H.K. Ltd.; 8B Tai Ping Industrial Park,
51 Ting Kok Road, Tai Po, N.T., Hong Kong. 852-26629298

