

MCF547x Integrated Microprocessor Electrical Characteristics

Applies to the MCF5470, MCF5471, MCF5472, MCF5473,
MCF5474, and MCF5475

This chapter contains electrical specification tables and reference timing diagrams for the MCF547x microprocessor. This section contains detailed information on power considerations, DC/AC electrical characteristics, and AC timing specifications of the MCF547x.

NOTE

The parameters specified in this MPU document supersede any values found in the module specifications.

1 Maximum Ratings

Table 1 lists maximum and minimum ratings for supply and operating voltages and storage temperature. Operating outside of these ranges may cause erratic behavior or damage to the processor.

Table of Contents

1	Maximum Ratings.....	1
2	Thermal Characteristics	2
3	DC Electrical Specifications	3
4	Supply Voltage Sequencing and Separation Cautions	5
5	Output Driver Capability and Loading	6
6	PLL Timing Specifications	7
7	Reset Timing Specifications	8
8	FlexBus.....	8
9	SDRAM Bus	11
10	PCI Bus	17
11	Fast Ethernet AC Timing Specifications	18
12	General Timing Specifications.....	21
13	I ² C Input/Output Timing Specifications	21
14	JTAG and Boundary Scan Timing	22
15	DSPI Electrical Specifications	25
16	Timer Module AC Timing Specifications.....	25
17	Revision History	26

Table 1. Absolute Maximum Ratings

Rating	Symbol	Value	Units
External (I/O pads) supply voltage (3.3-V power pins)	EV_{DD}	-0.3 to +4.0	V
Internal logic supply voltage	IV_{DD}	-0.5 to +2.0	V
Memory (I/O pads) supply voltage (2.5-V power pins)	$SD V_{DD}$	-0.3 to +4.0 SDR Memory -0.3 to +2.8 DDR Memory	V
PLL supply voltage	$PLL V_{DD}$	-0.5 to +2.0	V
Internal logic supply voltage, input voltage level	V_{in}	-0.5 to +3.6	V
Storage temperature range	T_{stg}	-55 to +150	°C

2 Thermal Characteristics

2.1 Operating Temperatures

Table 2 lists junction and ambient operating temperatures.

Table 2. Operating Temperatures

Characteristic	Symbol	Value	Units
Maximum operating junction temperature	T_j	105	°C
Maximum operating ambient temperature	T_{Amax}	<70 ¹	°C
Minimum operating ambient temperature	T_{Amin}	-0	°C

NOTES:

¹ This published maximum operating ambient temperature should be used only as a system design guideline. All device operating parameters are guaranteed only when the junction temperature lies within the specified range.

2.2 Thermal Resistance

Table 3 lists thermal resistance values.

Table 3. Thermal Resistance

Characteristic	Symbol	Value	Unit
324 pin TEPBGA — Junction to ambient, natural convection Four layer board (2s2p)	θ_{JMA}	22–24 ^{1,2}	°CW
388 pin TEPBGA — Junction to ambient, natural convection Four layer board (2s2p)	θ_{JMA}	20–22 ^{1,2}	°CW
Junction to ambient (@200 ft/min) Four layer board (2s2p)	θ_{JMA}	23 ^{1,2}	°CW
Junction to board	θ_{JB}	15 ³	°CW
Junction to case	θ_{JC}	10 ⁴	°CW
Junction to top of package Natural convection	Ψ_{jt}	2 ^{1,5}	°CW

NOTES:

- ¹ θ_{JA} and Ψ_{jt} parameters are simulated in accordance with EIA/JESD Standard 51-2 for natural convection. Freescale recommends the use of θ_{JA} and power dissipation specifications in the system design to prevent device junction temperatures from exceeding the rated specification. System designers should be aware that device junction temperatures can be significantly influenced by board layout and surrounding devices. Conformance to the device junction temperature specification can be verified by physical measurement in the customer's system using the Ψ_{jt} parameter, the device power dissipation, and the method described in EIA/JESD Standard 51-2.
- ² Per JEDEC JESD51-6 with the board horizontal.
- ³ Thermal resistance between the die and the printed circuit board per JEDEC JESD51-8. Board temperature is measured on the top surface of the board near the package.
- ⁴ Thermal resistance between the die and the case top surface as measured by the cold plate method (MIL SPEC-883 Method 1012.1).
- ⁵ Thermal characterization parameter indicating the temperature difference between package top and the junction temperature per JEDEC JESD51-2. When Greek letters are not available, the thermal characterization parameter is written as Psi-JT.

3 DC Electrical Specifications

Table 4 lists DC electrical operating temperatures. This table is based on an operating voltage of $EV_{DD} = 3.3 V_{DC} \pm 0.3 V_{DC}$ and IV_{DD} of $1.5 \pm 0.07 V_{DC}$.

Table 4. DC Electrical Specifications

Characteristic	Symbol	Min	Max	Units
External (I/O pads) operation voltage range	EV_{DD}	3.0	3.6	V
Memory (I/O pads) operation voltage range (DDR Memory)	$SD V_{DD}$	2.30	2.70	V
Internal logic operation voltage range ¹	IV_{DD}	1.43	1.58	V
PLL Analog operation voltage range ¹	$PLL V_{DD}$	1.43	1.58	V
USB oscillator operation voltage range	USB_OSV_{DD}	3.0	3.6	V
USB digital logic operation voltage range	$USBV_{DD}$	3.0	3.6	V
USB PHY operation voltage range	USB_PHYV_{DD}	3.0	3.6	V
USB oscillator analog operation voltage range	USB_OSCAV_{DD}	1.43	1.58	V
USB PLL operation voltage range	USB_PLLV_{DD}	1.43	1.58	V
Input high voltage SSTL 3.3V (SDR DRAM)	V_{IH}	2.0	3.6	V
Input low voltage SSTL 3.3V (SDR DRAM)	V_{IL}	-0.5	0.8	V
Input high voltage SSTL 2.5V (DDR DRAM)	V_{IH}	2.0	2.8	V
Input low voltage SSTL 2.5V (DDR DRAM)	V_{IL}	-0.5	0.8	V
Output high voltage $I_{OH} = 8\text{ mA}, 16\text{ mA}, 24\text{ mA}$	V_{OH}	2.4	—	V
Output low voltage $I_{OL} = 8\text{ mA}, 16\text{ mA}, 24\text{ mA}$ ⁵	V_{OL}	—	0.5	V
Capacitance ² , $V_{in} = 0\text{ V}, f = 1\text{ MHz}$	C_{IN}	—	TBD	pF

NOTES:

- ¹ IV_{DD} and $PLL V_{DD}$ should be at the same voltage. $PLL V_{DD}$ should have a filtered input. Please see Figure 1 for an example circuit. Note: There are three $PLL V_{DD}$ inputs. A filter circuit should be used on each $PLL V_{DD}$ input.
- ² Capacitance C_{IN} is periodically sampled rather than 100% tested.

3.1 PLL Power Filtering

To further enhance noise isolation, an external filter is strongly recommended for PLL analog V_{DD} pins. The filter shown in [Figure 1](#) should be connected between the board V_{DD} and the PLL V_{DD} pins. The resistor and capacitors should be placed as close to the dedicated PLL V_{DD} pin as possible.

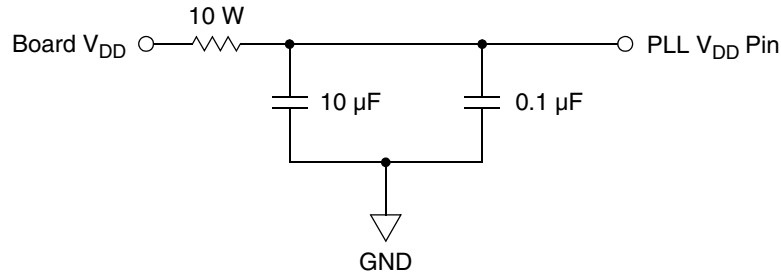

Figure 1. System PLL V_{DD} Power Filter

3.2 USB Power Filtering

To minimize noise, external filters are required for each of the USB power pins. The filter shown in [Figure 2](#) should be connected between the board EV_{DD} or IV_{DD} and each of the USB V_{DD} pins. The resistor and capacitors should be placed as close to the dedicated USB V_{DD} pin as possible. A separate filter circuit should be included for each USB V_{DD} pin, a total of five circuits.

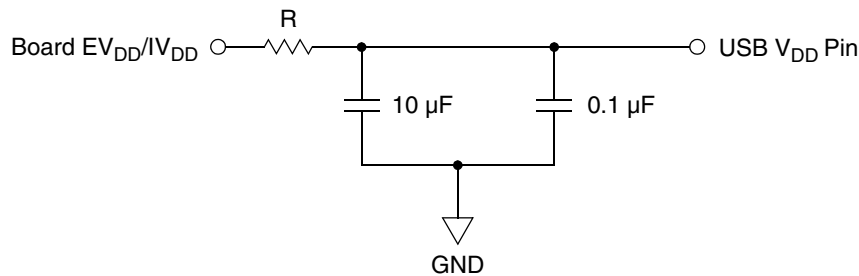

Figure 2. USB V_{DD} Power Filter

NOTE

In addition to the above filter circuitry, a 0.01 F capacitor is also recommended in parallel with those shown.

[Table 5](#) lists the resistor values and supply voltages to be used in the circuit for each of the USB V_{DD} pins.

Table 5. USB Filter Circuit Values

USB V_{DD} Pin	Nominal Voltage	Resistor Value (R)
USB_OSCVDD	3.3V	0 Ω
USBVDD	3.3V	0 Ω
USB_PHYVDD	3.3V	0 Ω
USB_OSCAVDD	1.5V	0 Ω
USB_PLLVDD	1.5V	10 Ω

4 Supply Voltage Sequencing and Separation Cautions

Figure 3 shows situations in sequencing the I/O V_{DD} (EV_{DD}), SDRAM V_{DD} ($SD V_{DD}$), PLL V_{DD} ($PLL V_{DD}$), and Core V_{DD} (IV_{DD}).

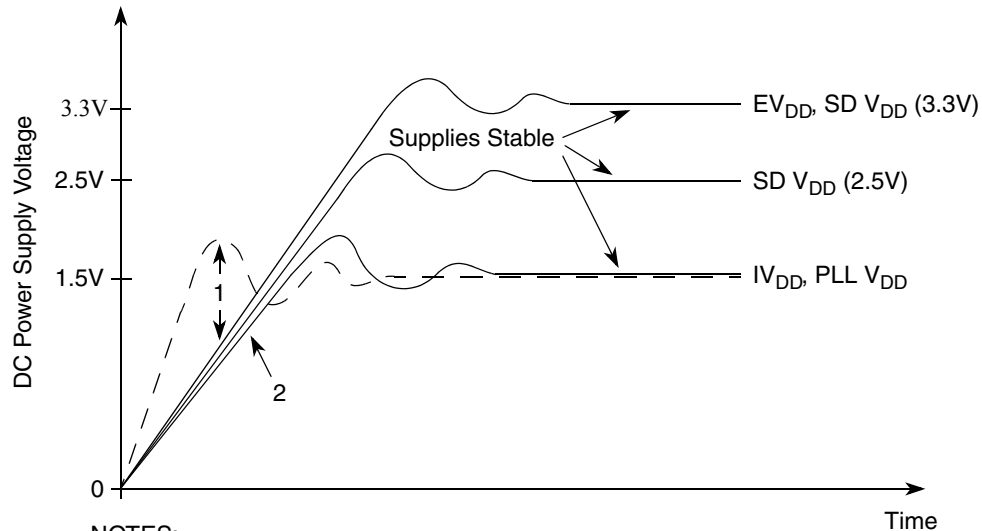

NOTES:

1. IV_{DD} should not exceed EV_{DD} , $SD V_{DD}$ or $PLL V_{DD}$ by more than 0.4V at any time, including power-up.
2. Recommended that $IV_{DD}/PLL V_{DD}$ should track $EV_{DD}/SD V_{DD}$ up to 0.9V, then separate for completion of ramps.
3. Input voltage must not be greater than the supply voltage (EV_{DD} , $SD V_{DD}$, IV_{DD} , or $PLL V_{DD}$) by more than 0.5V at any time, including during power-up.
4. Use 1 microsecond or slower rise time for all supplies.

Figure 3. Supply Voltage Sequencing and Separation Cautions

The relationship between $SD V_{DD}$ and EV_{DD} is non-critical during power-up and power-down sequences. Both $SD V_{DD}$ (2.5V or 3.3V) and EV_{DD} are specified relative to IV_{DD} .

4.1 Power Up Sequence

If $EV_{DD}/SD V_{DD}$ are powered up with the IV_{DD} at 0V, then the sense circuits in the I/O pads will cause all pad output drivers connected to the $EV_{DD}/SD V_{DD}$ to be in a high impedance state. There is no limit on how long after $EV_{DD}/SD V_{DD}$ powers up before IV_{DD} must power up. IV_{DD} should not lead the EV_{DD} , $SD V_{DD}$ or $PLL V_{DD}$ by more than 0.4V during power ramp up, or there will be high current in the internal ESD protection diodes. The rise times on the power supplies should be slower than 1 microsecond to avoid turning on the internal ESD protection clamp diodes.

The recommended power up sequence is as follows:

1. Use 1 microsecond or slower rise time for all supplies.
2. $IV_{DD}/PLL V_{DD}$ and $EV_{DD}/SD V_{DD}$ should track up to 0.9V, then separate for the completion of ramps with $EV_{DD}/SD V_{DD}$ going to the higher external voltages. One way to accomplish this is to use a low drop-out voltage regulator.

4.2 Power Down Sequence

If IV_{DD} PLL V_{DD} are powered down first, then sense circuits in the I/O pads will cause all output drivers to be in a high impedance state. There is no limit on how long after IV_{DD} and PLL V_{DD} power down before EV_{DD} or SD V_{DD} must power down. IV_{DD} should not lag EV_{DD} , SD V_{DD} , or PLL V_{DD} going low by more than 0.4V during power down or there will be undesired high current in the ESD protection diodes. There are no requirements for the fall times of the power supplies.

The recommended power down sequence is as follows:

1. Drop IV_{DD} /PLL V_{DD} to 0V
2. Drop EV_{DD} /SD V_{DD} supplies

5 Output Driver Capability and Loading

Table 6 lists values for drive capability and output loading.

Table 6. I/O Driver Capability

Signal	Drive Capability	Output Load (C_L)
SDRAMC (SDADDR[12:0], SDDATA[31:0], \overline{RAS} , \overline{CAS} , SDDM[3:0], SDWE, SDBA[1:0])	24 mA	15 pF
SDRAMC DQS and clocks (SDDQS[3:0], SDRDQS, SDCLK[1:0], SDCLK[1:0], SDCKE)	24 mA	15 pF
SDRAMC chip selects (\overline{SDCS} [3:0])	24 mA	15 pF
FlexBus (AD[31:0], \overline{FBCS} [5:0], ALE, R/\overline{W} , $\overline{BE/BWE}$ [3:0], \overline{OE})	16 mA	20 pF
FEC ($EnMDIO$, $EnMDC$, $EnTXEN$, $EnTXD$ [3:0], $EnTXER$)	8 mA	15 pF
Timer (TOUT[3:0])	8 mA	50 pF
\overline{DACK} [1:0]	8 mA	30 pF
PSC ($PSCnTXD$ [3:0], $\overline{PSCnRTS}/PSCnFSYNC$,	8 mA	30 pF
DSPI (DSPISOUT, DSPICS0/SS, DSPICS[2:3], DSPICS5/PCSS)	24 mA	50 pF
PCI (PCIID[31:0], PCIBG[4:1], PCIBG0/PCIREQOUT, PCIDEVSEL, PCICXBE[3:0], PCIFRM, PCIPERR, PCIRESET, PCISERR, PCISTOP, PCIPAR, PCITRDY, PCIIRDY)	16 mA	50 pF
I2C (SCL, SDA)	8 mA	50 pF
BDM (PSTCLK, PSTDDATA[7:0], DSO/TDO,	8 mA	25 pF
RSTO	8 mA	50 pF

6 PLL Timing Specifications

The specifications in [Table 7](#) are for the CLKIN pin.

Table 7. Clock Timing Specification

Num	Characteristic	Min	Max	Units
C1	Cycle time	15.0	40	ns
C2	Rise time (20% of Vdd to 80% of vdd)	—	2	ns
C3	Fall time (80% of Vdd to 20% of Vdd)	—	2	ns
C4	Duty cycle (at 50% of Vdd)	40	60	%

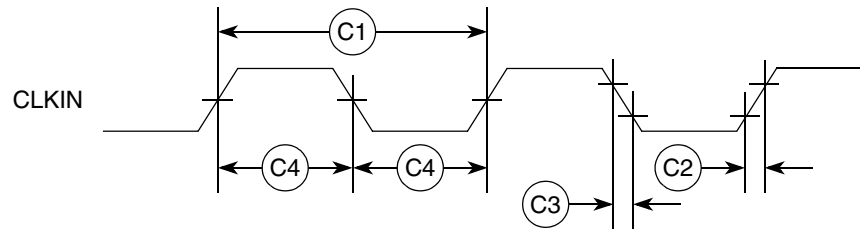

Figure 4. Input Clock Timing Diagram

[Table 8](#) shows the supported PLL encodings.

Table 8. MCF547X Divide Ratio Encodings

AD[12:8] ¹	Clock Ratio	CLKIN—PCI and FlexBus Frequency Range (MHz)	Internal XLB, SDRAM Bus, and PSTCLK Frequency Range (MHz)	Core Frequency Range (MHz)
00011	1:2	41.6–66.66	83.33–133.33	166.66–266.66
00101	1:2	25.0–44.4	50.0–88.8 ²	100.0–177.66
01111	1:4	25.0–33.3	100–133.33	200–266.66

NOTES:

¹ All other values of AD[12:8] are reserved.

² Note that DDR memories typically have a minimum speed of 83 MHz. Some vendors specify down to 75 MHz. Check with memory component specifications to verify.

[Figure 5](#) correlates CLKIN, internal bus, and core clock frequencies for the 1x–4x multipliers.

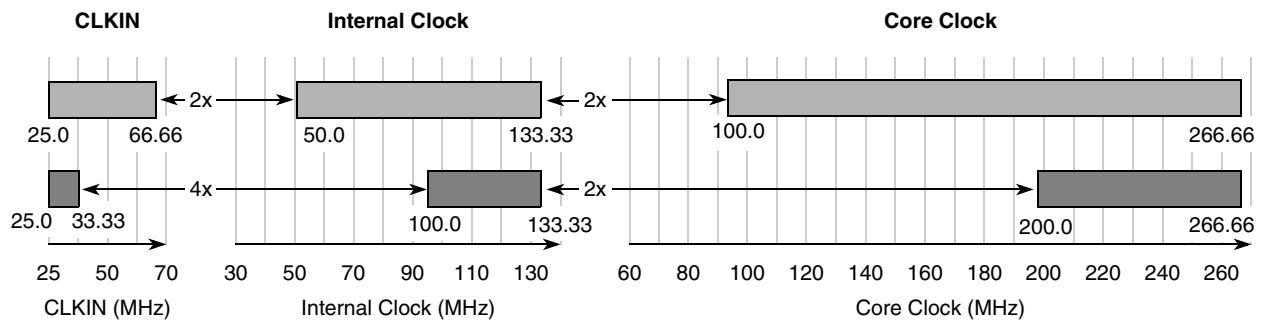

Figure 5. CLKIN, Internal Bus, and Core Clock Ratios

7 Reset Timing Specifications

Table 9 lists specifications for the reset timing parameters shown in Figure 6

Table 9. Reset Timing Specification

Num	Characteristic	66 MHz CLKIN		Units
		Min	Max	
R1 ¹	Valid to CLKIN (setup)	8	—	nS
R2	CLKIN to invalid (hold)	1.0	—	nS
R3	$\overline{\text{RSTI}}$ to invalid (hold)	1.0	—	nS

NOTES:

¹ $\overline{\text{RSTI}}$ and FlexBus data lines are synchronized internally. Setup and hold times must be met only if recognition on a particular clock is required.

Figure 6 shows reset timing for the values in Table 9.

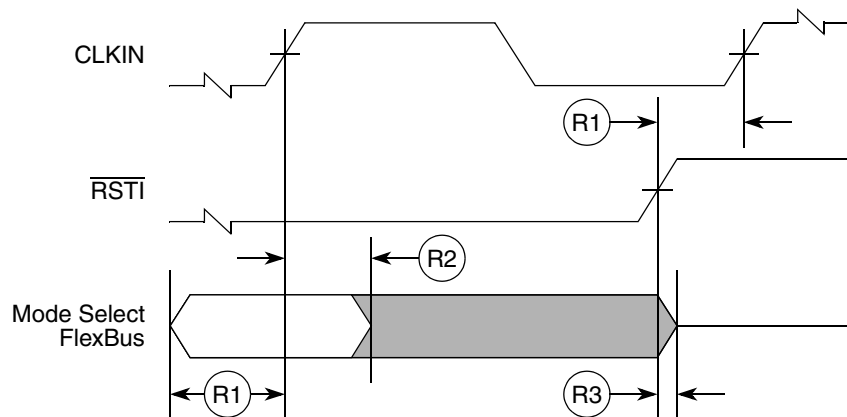

NOTE:

Mode selects are registered on the rising clock edge before the cycle in which $\overline{\text{RSTI}}$ is recognized as being negated.

Figure 6. Reset Timing

8 FlexBus

A multi-function external bus interface called FlexBus is provided on the MCF5472 with basic functionality to interface to slave-only devices up to a maximum bus frequency of 66 MHz. It can be directly connected to asynchronous or synchronous devices such as external boot ROMs, flash memories, gate-array logic, or other simple target (slave) devices with little or no additional circuitry. For asynchronous devices, a simple chip-select based interface can be used. The FlexBus interface has six general purpose chip-selects (FBCS[5:0]). Chip-select FBCS0 can be dedicated to boot ROM access and can be programmed to be byte (8 bits), word (16 bits), or longword (32 bits) wide. Control signal timing is compatible with common ROM / flash memories.

8.1 FlexBus AC Timing Characteristics

The following timing numbers indicate when data will be latched or driven onto the external bus, relative to the system clock.

Table 10. FlexBus AC Timing Specifications

Num	Characteristic	Min	Max	Unit	Notes
	Frequency of Operation	25	66	Mhz	¹
FB1	Clock Period (CLKIN)	15.15	40	ns	²
FB2	Address, Data, and Control Output Valid (AD[31:0], $\overline{\text{FBCS}}[5:0]$, R/W, ALE, TSIZ[1:0], $\overline{\text{BE}}/\overline{\text{BWE}}[3:0]$, $\overline{\text{OE}}$, and $\overline{\text{TBST}}$)	—	7.0	ns	³
FB3	Address, Data, and Control Output Hold ((AD[31:0], $\overline{\text{FBCS}}[5:0]$, R/W, ALE, TSIZ[1:0], $\overline{\text{BE}}/\overline{\text{BWE}}[3:0]$, $\overline{\text{OE}}$, and $\overline{\text{TBST}}$)	1	—	ns	^{3, 4}
FB4	Data Input Setup	3.5	—	ns	
FB5	Data Input Hold	0	—	ns	
FB6	Transfer Acknowledge ($\overline{\text{TA}}$) Input Setup	4	—	ns	
FB7	Transfer Acknowledge ($\overline{\text{TA}}$) Input Hold	0	—	ns	
FB8	Address Output Valid (PCIAD[31:0])	—	7.0	ns	⁵
FB9	Address Output Hold (PCIAD[31:0])	0	—	ns	⁵

NOTES:

- ¹ The frequency of operation is the same as the PCI frequency of operation. The MCF547X supports a single external reference clock (CLKIN). This signal defines the frequency of operation for both FlexBus and PCI.
- ² Max cycle rate is determined by CLKIN and how the user has the system PLL configured.
- ³ Timing for chip selects only applies to the $\overline{\text{FBCS}}[5:0]$ signals. Please see [Section 9.2, "DDR SDRAM AC Timing Characteristics"](#) for $\overline{\text{SDCS}}[3:0]$ timing.
- ⁴ The FlexBus supports programming an extension of the address hold. Please consult the MCF547X specification manual for more information.
- ⁵ These specs are used when the PCIAD[31:0] signals are configured as 32-bit, non-muxed FlexBus address signals.

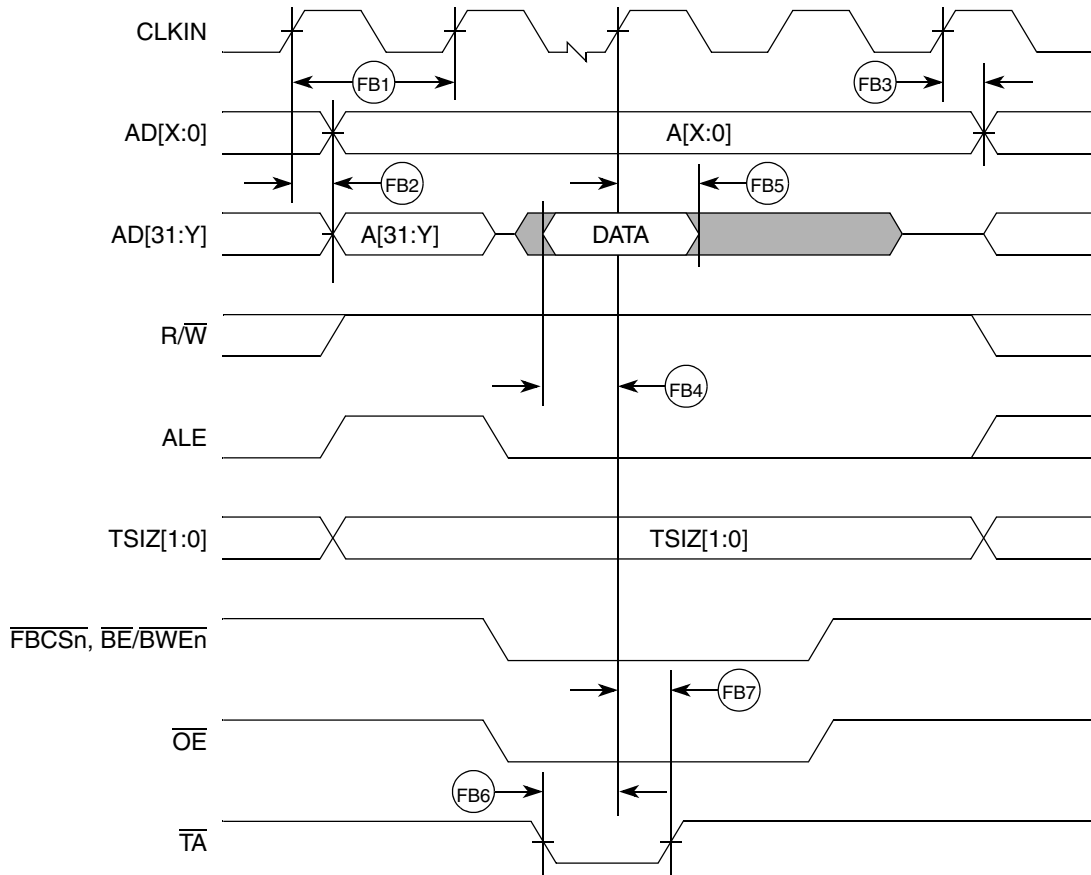

Figure 7. FlexBus Read Timing

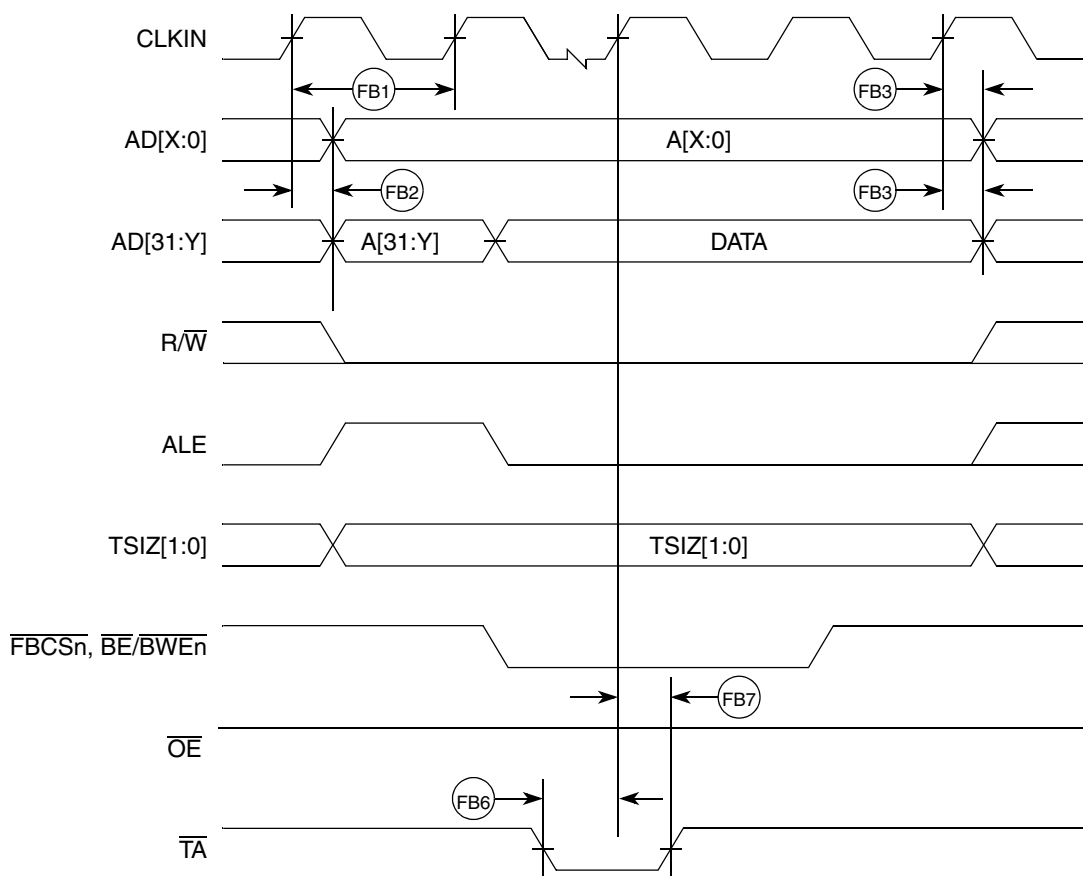

Figure 8. FlexBus Write Timing

9 SDRAM Bus

The SDRAM controller supports accesses to main SDRAM memory from any internal master. It supports either standard SDRAM or double data rate (DDR) SDRAM, but it does not support both at the same time. The SDRAM controller uses SSTL2 and SSTL3 I/O drivers. Both SSTL drive modes are programmable for either Class I or Class II drive strength.

9.1 SDR SDRAM AC Timing Characteristics

The following timing numbers indicate when data will be latched or driven onto the external bus, relative to the memory bus clock, when operating in SDR mode on write cycles and relative to SDR_DQS on read cycles. The MCF547x SDRAM controller is a DDR controller that has an SDR mode. Because it is designed to support DDR, a DQS pulse must still be supplied to the MCF547x for each data beat of an SDR read. The MCF547x accomplishes this by asserting a signal called SDR_DQS during read cycles. Care must be taken during board design to adhere to the following guidelines and specs with regard to the SDR_DQS signal and its usage.

Table 11. SDR Timing Specifications

Symbol	Characteristic	Min	Max	Unit	Notes
	Frequency of Operation	0	133	Mhz	1
SD1	Clock Period (t_{CK})	7.52	12	ns	2
SD2	Clock Skew (t_{SK})		TBD		
SD3	Pulse Width High (t_{CKH})	0.45	0.55	SDCLK	3
SD4	Pulse Width Low (t_{CKL})	0.45	0.55	SDCLK	4
SD5	Address, CKE, CAS, RAS, WE, BA, CS - Output Valid (t_{CMV})		$0.5 \times \text{SDCLK} + 1.0\text{ns}$	ns	
SD6	Address, CKE, CAS, RAS, WE, BA, CS - Output Hold (t_{CMH})	2.0		ns	
SD7	SDRDQS Output Valid (t_{DQSOV})		Self timed	ns	5
SD8	SDDQS[3:0] input setup relative to SDCLK ($t_{DQSI S}$)	$0.25 \times \text{SDCLK}$	$0.40 \times \text{SDCLK}$	ns	6
SD9	SDDQS[3:0] input hold relative to SDCLK (t_{DQSIH})	Does not apply. 0.5 SDCLK fixed width.			7
SD10	Data Input Setup relative to SDCLK (reference only) (t_{DIS})	$0.25 \times \text{SDCLK}$		ns	8
SD11	Data Input Hold relative to SDCLK (reference only) (t_{DIH})	1.0		ns	
SD12	Data and Data Mask Output Valid (t_{DV})		$0.75 \times \text{SDCLK} + 0.500\text{ns}$	ns	
SD13	Data and Data Mask Output Hold (t_{DH})	1.5		ns	

NOTES:

- ¹ The frequency of operation is either 2x or 4x the CLKIN frequency of operation. The MCF547X supports a single external reference clock (CLKIN). This signal defines the frequency of operation for both FlexBus and PCI, but SDRAM clock operates at the same frequency as the internal bus clock. Please see the PLL chapter of the *MCF547X Reference Manual* for more information on setting the SDRAM clock rate.
- ² SDCLK is one SDRAM clock in (ns).
- ³ Pulse width high plus pulse width low cannot exceed min and max clock period.
- ⁴ Pulse width high plus pulse width low cannot exceed min and max clock period.
- ⁵ SDR_DQS is designed to pulse 0.25 clock before the rising edge of the memory clock. This is a guideline only. Subtle variation from this guideline is expected. SDR_DQS will only pulse during a read cycle and one pulse will occur for each data beat.
- ⁶ SDR_DQS is designed to pulse 0.25 clock before the rising edge of the memory clock. This spec is a guideline only. Subtle variation from this guideline is expected. SDR_DQS will only pulse during a read cycle and one pulse will occur for each data beat.
- ⁷ The SDR_DQS pulse is designed to be 0.5 clock in width. The timing of the rising edge is most important. The falling edge does not affect the memory controller.
- ⁸ Since a read cycle in SDR mode still uses the DQS circuit within the MCF547X, it is most critical that the data valid window be centered 1/4 clk after the rising edge of DQS. Ensuring that this happens will result in successful SDR reads. The input setup spec is just provided as guidance.

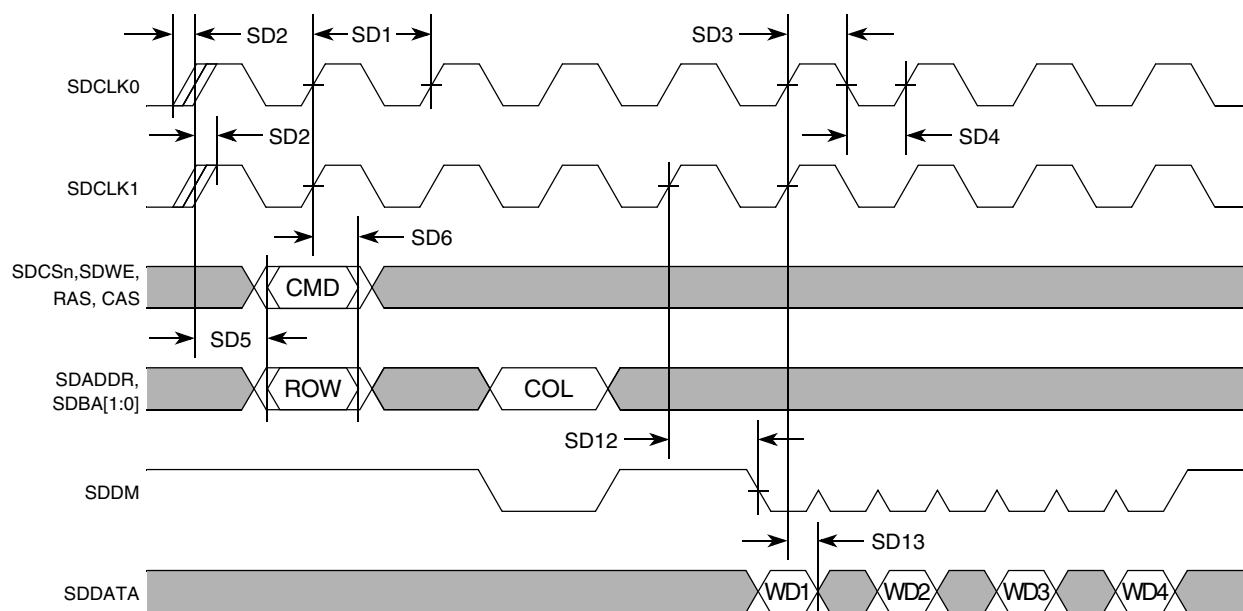

Figure 9. SDR Write Timing

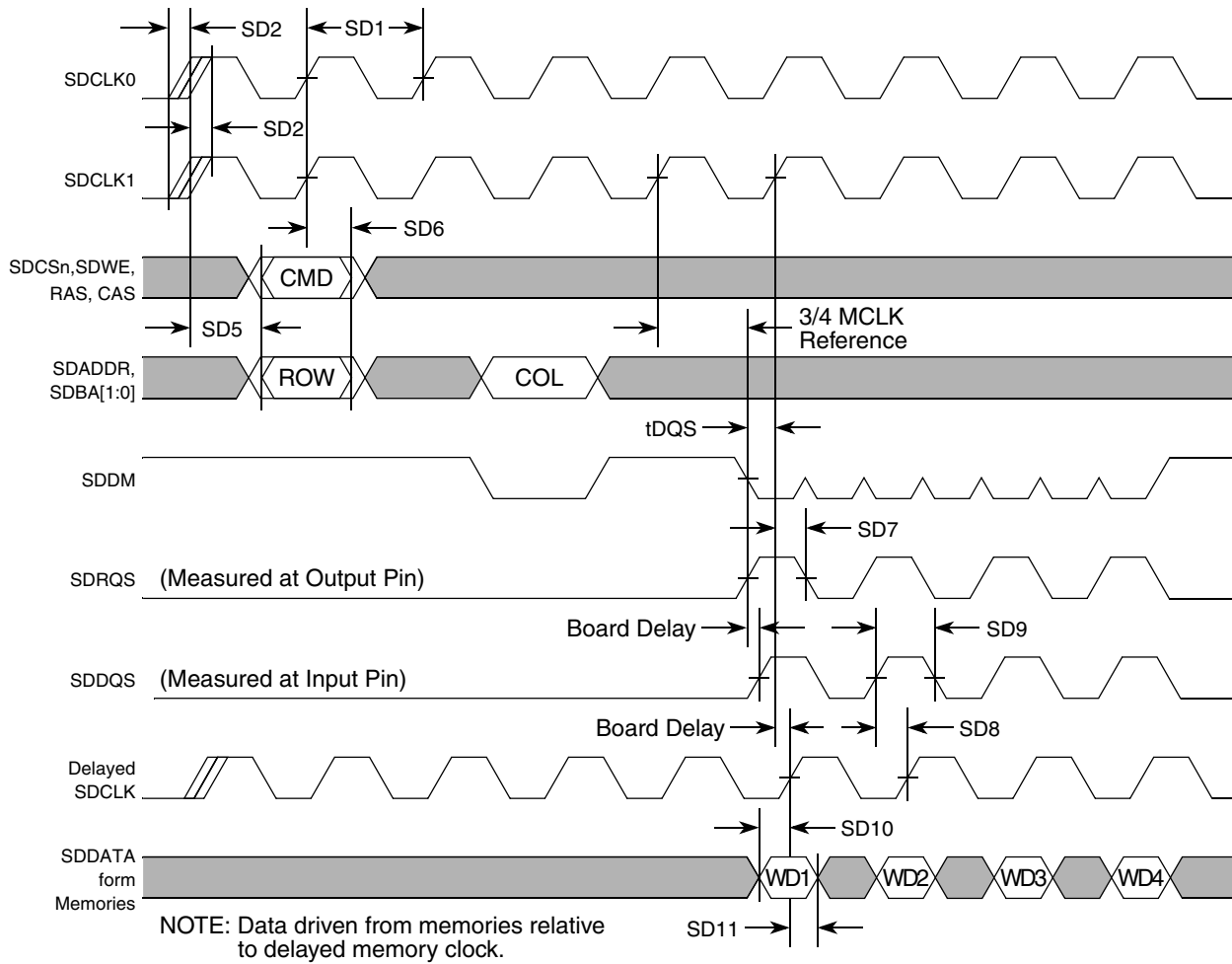

Figure 10. SDR Read Timing

9.2 DDR SDRAM AC Timing Characteristics

When using the DDR SDRAM controller, the following timing numbers must be followed to properly latch or drive data onto the memory bus. All timing numbers are relative to the four DQS byte lanes.

Table 12 shows the DDR clock crossover specifications.

Table 12. DDR Clock Crossover Specifications

Symbol	Characteristic	Min	Max	Unit
V _{MP}	Clock output mid-point voltage	1.05	1.45	V
V _{OUT}	Clock output voltage level	-0.3	SD_VDD + 0.3	V
V _{ID}	Clock output differential voltage (peak to peak swing)	0.7	SD_VDD + 0.6	V
V _{IX}	Clock crossing point voltage ¹	1.05	1.45	V

NOTES:

¹ The clock crossover voltage is only guaranteed when using the highest drive strength option for the SDCLK[1:0] and SDCLK[1:0] signals.

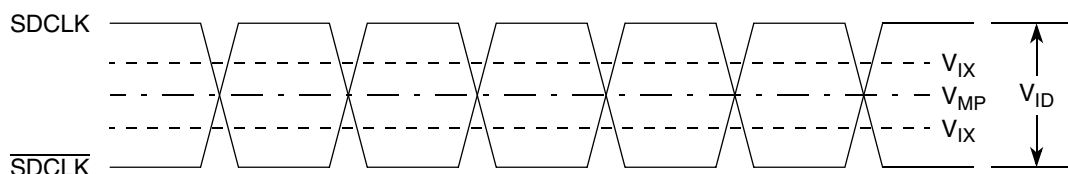

Figure 11. DDR Clock Timing Diagram

Table 13. DDR Timing Specifications

Symbol	Characteristic	Min	Max	Unit	Notes
	Frequency of Operation	50 ¹	133	MHz	2
DD1	Clock Period (t_{CK})	7.52	12	ns	3
DD2	Pulse Width High (t_{CKH})	0.45	0.55	SDCLK	4
DD3	Pulse Width Low (t_{CKL})	0.45	0.55	SDCLK	5
DD4	Address, SDCKE, \overline{CAS} , \overline{RAS} , \overline{WE} , SDBA, \overline{SDCS} —Output Valid (t_{CMV})	—	$0.5 \times \text{SDCLK} + 1.0 \text{ ns}$	ns	6
DD5	Address, SDCKE, \overline{CAS} , \overline{RAS} , \overline{WE} , SDBA, \overline{SDCS} —Output Hold (t_{CMH})	2.0	—	ns	
DD6	Write Command to first DQS Latching Transition (t_{DQSS})	—	1.25	SDCLK	
DD7	Data and Data Mask Output Setup (DQ→DQS) Relative to DQS (DDR Write Mode) (t_{QS})	1.0	—	ns	7 8
DD8	Data and Data Mask Output Hold (DQS→DQ) Relative to DQS (DDR Write Mode) (t_{QH})	1.0	—	ns	9
DD9	Input Data Skew Relative to DQS (Input Setup) (t_{IS})		1	ns	10
DD10	Input Data Hold Relative to DQS (t_{IH})	$0.25 \times \text{SDCLK} + 0.5 \text{ ns}$	—	ns	11
DD11	DQS falling edge to SDCLK rising (output setup time) (t_{DSS})	0.5	—	ns	
DD12	DQS falling edge from SDCLK rising (output hold time) (t_{DSH})	0.5	—	ns	
DD13	DQS input read preamble width (t_{RPRE})	0.9	1.1	SDCLK	
DD14	DQS input read postamble width (t_{RPST})	0.4	0.6	SDCLK	
DD15	DQS output write preamble width (t_{WPRE})	0.25	—	SDCLK	
DD16	DQS output write postamble width (t_{WPST})	0.4	0.6	SDCLK	

NOTES:

- ¹ Note that DDR memories typically have a minimum speed specification of 83 MHz. Check with memory component specifications to verify.
- ² The frequency of operation is either 2x or 4x the CLKIN frequency of operation. The MCF547X supports a single external reference clock (CLKIN). This signal defines the frequency of operation for both FlexBus and PCI, but SDRAM clock operates at the same frequency as the internal bus clock. Please see the reset configuration signals description in the “Signal Descriptions” chapter within the *MCF547x Reference Manual*.
- ³ SDCLK is one memory clock in (ns).
- ⁴ Pulse width high plus pulse width low cannot exceed max clock period.
- ⁵ Pulse width high plus pulse width low cannot exceed max clock period.
- ⁶ Command output valid should be 1/2 the memory bus clock (SDCLK) plus some minor adjustments for process, temperature, and voltage variations.
- ⁷ This specification relates to the required input setup time of today's DDR memories. SDDATA[31:24] is relative to SDDQS3, SDDATA[23:16] is relative to SDDQS2, SDDATA[15:8] is relative to SDDQS1, and SDDATA[7:0] is relative to SDDQS0.

SDRAM Bus

- ⁸ The first data beat will be valid before the first rising edge of SDDQS and after the SDDQS write preamble. The remaining data beats will be valid for each subsequent SDDQS edge.
- ⁹ This specification relates to the required hold time of today's DDR memories. SDDATA[31:24] is relative to SDDQS3, SDDATA[23:16] is relative to SDDQS2, SDDATA[15:8] is relative to SDDQS1, and SDDATA[7:0] is relative SDDQS0.
- ¹⁰ Data input skew is derived from each SDDQS clock edge. It begins with a SDDQS transition and ends when the last data line becomes valid. This input skew must include DDR memory output skew and system level board skew (due to routing or other factors).
- ¹¹ Data input hold is derived from each SDDQS clock edge. It begins with a SDDQS transition and ends when the first data line becomes invalid.

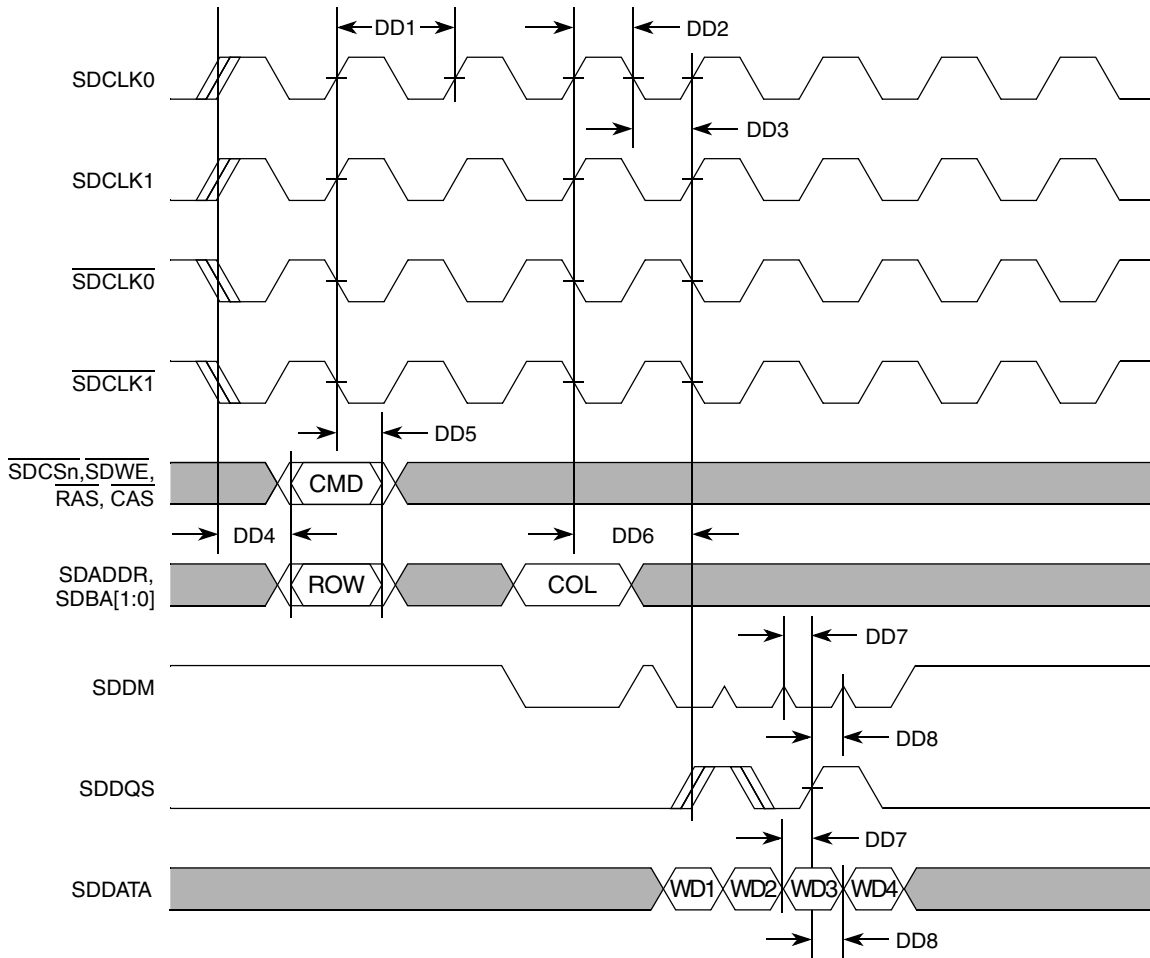

Figure 12. DDR Write Timing

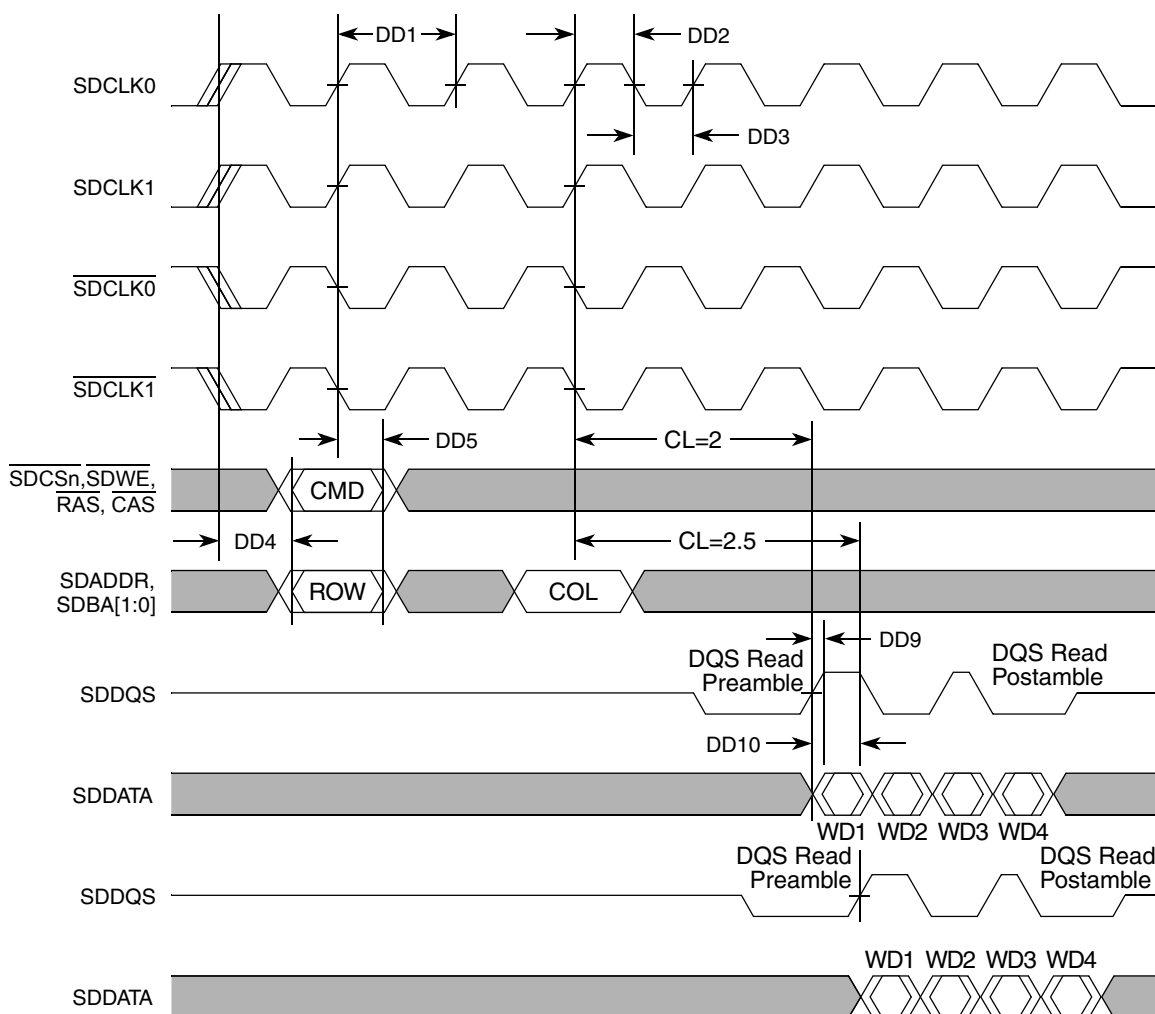

Figure 13. DDR Read Timing

10 PCI Bus

The PCI bus on the MCF547x is PCI 2.2 compliant. The following timing numbers are mostly from the PCI 2.2 spec. Please refer to the PCI 2.2 spec for a more detailed timing analysis.

Table 14. PCI Timing Specifications

Num	Characteristic	Min	Max	Unit	Notes
	Frequency of Operation	25	66	MHz	1
P1	Clock Period (t_{CK})	15.15	40	ns	2
P2	Address, Data, and Command (33 < PCI ≤ 66 Mhz)—Input Setup (t_{IS})	3.0	—	ns	
P3	Address, Data, and Command (0 < PCI ≤ 33 Mhz)—Input Setup (t_{IS})	7.0	—	ns	
P4	Address, Data, and Command (33–66 Mhz)—Output Valid (t_{DV})	—	6.0	ns	3
P5	Address, Data, and Command (0–33 Mhz) - Output Valid (t_{DV})	—	11.0	ns	

Table 14. PCI Timing Specifications (continued)

Num	Characteristic	Min	Max	Unit	Notes
P6	PCI signals (0–66 Mhz) - Output Hold (t_{DH})	0	—	ns	4
P7	PCI signals (0–66 Mhz) - Input Hold (t_{IH})	0	—	ns	5
P8	PCI REQ/GNT (33 < PCI ≤ 66Mhz) - Output valid (t_{DV})	—	6	ns	6
P9	PCI REQ/GNT (0 < PCI ≤ 33Mhz) - Output valid (t_{DV})	—	12	ns	
P10	PCI REQ/GNT (33 < PCI ≤ 66Mhz) - Input Setup (t_{IS})	—	5	ns	
P11	PCI REQ (0 < PCI ≤ 33Mhz) - Input Setup (t_{IS})	12	—	ns	
P12	PCI GNT (0 < PCI ≤ 33Mhz) - Input Setup (t_{IS})	10	—	ns	

NOTES:

- 1 Please see the reset configuration signals description in the “Signal Descriptions” chapter within the *MCF547x Reference Manual*. Also specific guidelines may need to be followed when operating the system PLL below certain frequencies.
- 2 Max cycle rate is determined by CLKIN and how the user has the system PLL configured.
- 3 All signals defined as PCI based signals. Does not include PTP (point-to-point) signals.
- 4 PCI 2.2 spec does not require an output hold time. Although the MCF547X may provide a slight amount of hold, it is not required or guaranteed.
- 5 PCI 2.2 spec requires zero input hold.
- 6 These signals are defined at PTP (Point-to-point) in the PCI 2.2 spec.

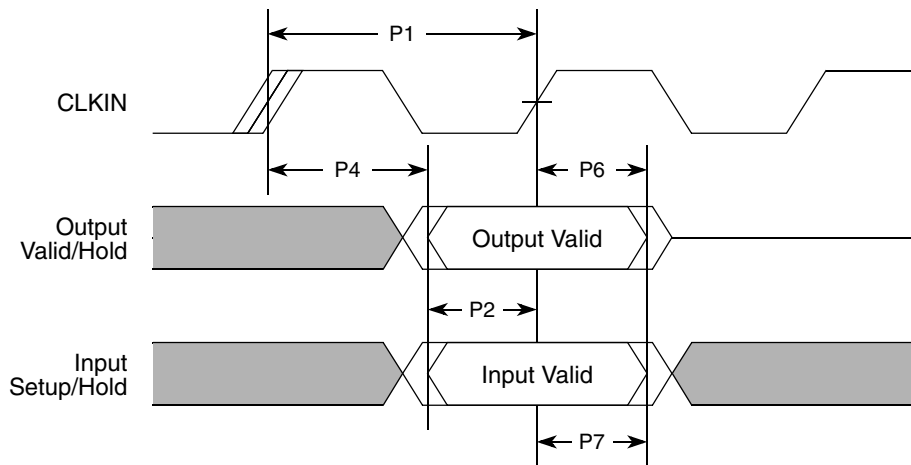

Figure 14. PCI Timing

11 Fast Ethernet AC Timing Specifications

11.1 MII/7-WIRE Interface Timing Specs

The following timing specs are defined at the chip I/O pin and must be translated appropriately to arrive at timing specs/constraints for the EMAC_10_100 I/O signals.

The following timing specs meet the requirements for both MII and 7-Wire style interfaces for a range of transceiver devices. If this interface is to be used with a specific transceiver device the timing specs may be altered to match that specific transceiver.

Table 15. MII Receive Signal Timing

Num	Characteristic	Min	Max	Unit
M1	RXD[3:0], RXDV, RXER to RXCLK setup	5	—	ns
M2	RXCLK to RXD[3:0], RXDV, RXER hold	5	—	ns
M3	RXCLK pulse width high	35%	65%	RXCLK period
M4	RXCLK pulse width low	35%	65%	RXCLK period

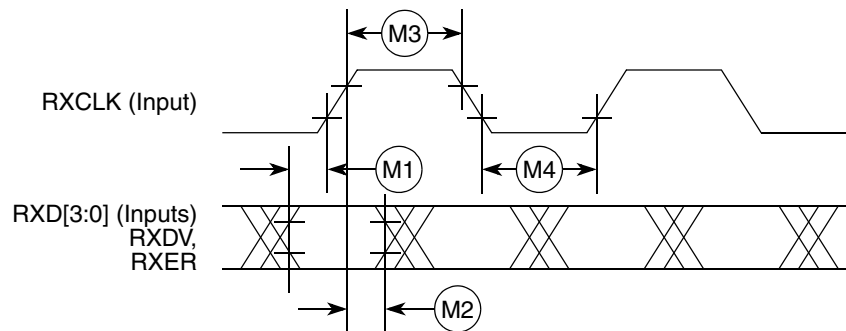

Figure 15. MII Receive Signal Timing Diagram

11.2 MII Transmit Signal Timing

Table 16. MII Transmit Signal Timing

Num	Characteristic	Min	Max	Unit
M5	TXCLK to TXD[3:0], TXEN, TXER invalid	0	—	ns
M6	TXCLK to TXD[3:0], TXEN, TXER valid	—	25	ns
M7	TXCLK pulse width high	35%	65%	TXCLK period
M8	TXCLK pulse width low	35%	65%	TXCLK period

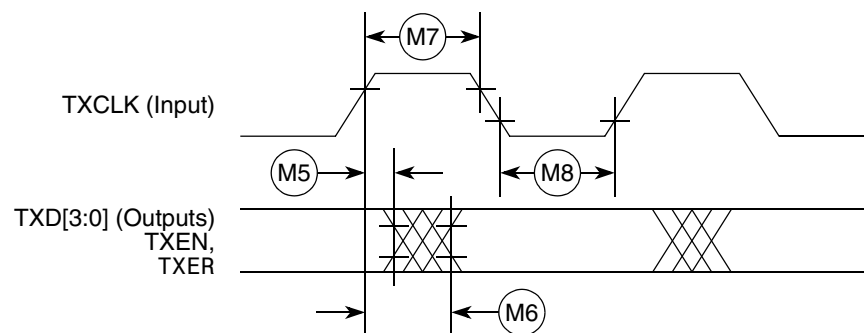

Figure 16. MII Transmit Signal Timing Diagram

11.3 MII Async Inputs Signal Timing (CRS, COL)

Table 17. MII Transmit Signal Timing

Num	Characteristic	Min	Max	Unit
M9	CRS, COL minimum pulse width	1.5	—	TX_CLK period

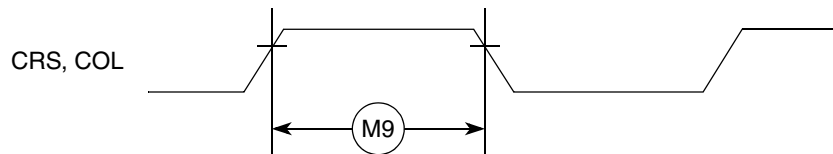

Figure 17. MII Async Inputs Timing Diagram

11.4 MII Serial Management Channel Timing (MDIO, MDC)

Table 18. MII Serial Management Channel Signal Timing

Num	Characteristic	Min	Max	Unit
M10	MDC falling edge to MDIO output invalid (min prop delay)	0	—	ns
M11	MDC falling edge to MDIO output valid (max prop delay)	—	25	ns
M12	MDIO (input) to MDC rising edge setup	10	—	ns
M13	MDIO (input) to MDC rising edge hold	0	—	ns
M14	MDC pulse width high	40%	60%	MDC period
M15	MDC pulse width low	40%	60%	MDC period

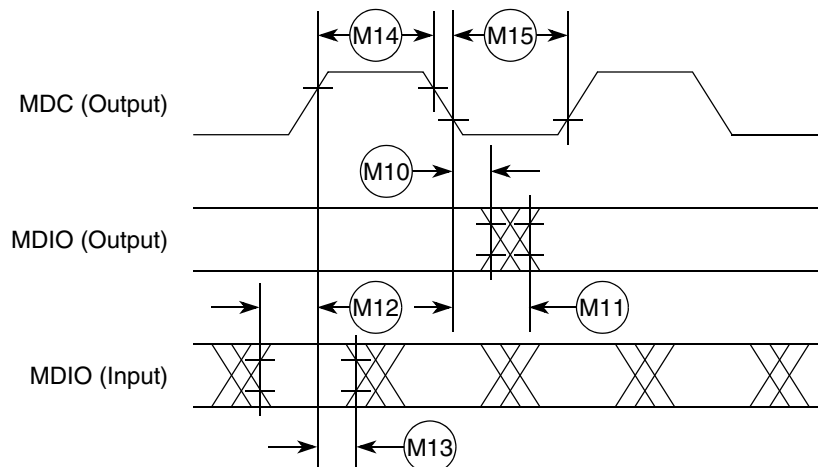

Figure 18. MII Serial Management Channel Timing Diagram

12 General Timing Specifications

Table 19 lists timing specifications for the GPIO, PSC, $\overline{\text{DREQ}}$, $\overline{\text{DACK}}$, and external interrupts.

Table 19. General AC Timing Specifications

Name	Characteristic	Min	Max	Unit
G1	CLKIN high to signal output valid	—	2	PSTCLK
G2	CLKIN high to signal invalid (output hold)	0	—	ns
G3	Signal input pulse width	2	—	PSTCLK

13 I²C Input/Output Timing Specifications

Table 20 lists specifications for the I²C input timing parameters shown in Figure 19.

Table 20. I²C Input Timing Specifications between SCL and SDA

Num	Characteristic	Min	Max	Units
I1	Start condition hold time	2	—	Bus clocks
I2	Clock low period	8	—	Bus clocks
I3	SCL/SDA rise time ($V_{IL} = 0.5 \text{ V}$ to $V_{IH} = 2.4 \text{ V}$)	—	1	mS
I4	Data hold time	0	—	ns
I5	SCL/SDA fall time ($V_{IH} = 2.4 \text{ V}$ to $V_{IL} = 0.5 \text{ V}$)	—	1	mS
I6	Clock high time	4	—	Bus clocks
I7	Data setup time	0	—	ns
I8	Start condition setup time (for repeated start condition only)	2	—	Bus clocks
I9	Stop condition setup time	2	—	Bus clocks

Table 21 lists specifications for the I²C output timing parameters shown in Figure 19.

Table 21. I²C Output Timing Specifications between SCL and SDA

Num	Characteristic	Min	Max	Units
I1 ¹	Start condition hold time	6	—	Bus clocks
I2 ¹	Clock low period	10	—	Bus clocks
I3 ²	SCL/SDA rise time ($V_{IL} = 0.5 \text{ V}$ to $V_{IH} = 2.4 \text{ V}$)	—	—	μS
I4 ¹	Data hold time	7	—	Bus clocks
I5 ³	SCL/SDA fall time ($V_{IH} = 2.4 \text{ V}$ to $V_{IL} = 0.5 \text{ V}$)	—	3	ns
I6 ¹	Clock high time	10	—	Bus clocks
I7 ¹	Data setup time	2	—	Bus clocks
I8 ¹	Start condition setup time (for repeated start condition only)	20	—	Bus clocks
I9 ¹	Stop condition setup time	10	—	Bus clocks

JTAG and Boundary Scan Timing

NOTES:

- ¹ Note: Output numbers depend on the value programmed into the IFDR; an IFDR programmed with the maximum frequency (IFDR = 0x20) results in minimum output timings as shown in [Table 21](#). The I²C interface is designed to scale the actual data transition time to move it to the middle of the SCL low period. The actual position is affected by the prescale and division values programmed into the IFDR; however, the numbers given in [Table 21](#) are minimum values.
- ² Because SCL and SDA are open-collector-type outputs, which the processor can only actively drive low, the time SCL or SDA take to reach a high level depends on external signal capacitance and pull-up resistor values.
- ³ Specified at a nominal 50-pF load.

Figure 19 shows timing for the values in [Table 20](#) and [Table 21](#).

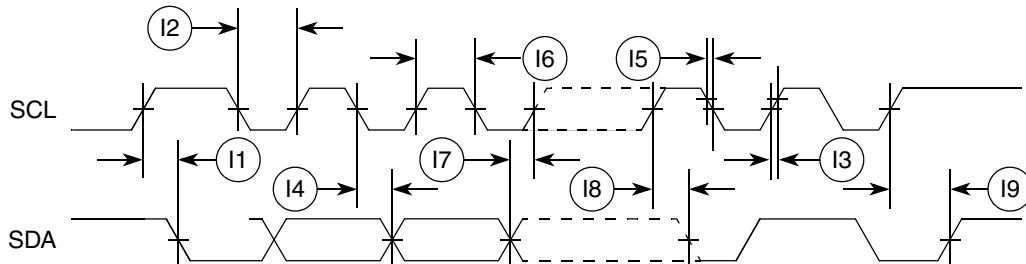

Figure 19. I²C Input/Output Timings

14 JTAG and Boundary Scan Timing

Table 22. JTAG and Boundary Scan Timing

Num	Characteristics ¹	Symbol	Min	Max	Unit
J1	TCLK Frequency of Operation	f_{JCYC}	DC	10	MHz
J2	TCLK Cycle Period	t_{JCYC}	2	—	t_{CK}
J3	TCLK Clock Pulse Width	t_{JCW}	15.15	—	ns
J4	TCLK Rise and Fall Times	t_{JCRF}	0.0	3.0	ns
J5	Boundary Scan Input Data Setup Time to TCLK Rise	t_{BSDST}	5.0	—	ns
J6	Boundary Scan Input Data Hold Time after TCLK Rise	t_{BSDHT}	24.0	—	ns
J7	TCLK Low to Boundary Scan Output Data Valid	t_{BSDV}	0.0	15.0	ns
J8	TCLK Low to Boundary Scan Output High Z	t_{BSDZ}	0.0	15.0	ns
J9	TMS, TDI Input Data Setup Time to TCLK Rise	t_{TAPBST}	5.0	—	ns
J10	TMS, TDI Input Data Hold Time after TCLK Rise	t_{TAPBHT}	10.0	—	ns
J11	TCLK Low to TDO Data Valid	t_{TDODV}	0.0	20.0	ns
J12	TCLK Low to TDO High Z	t_{TDODZ}	0.0	15.0	ns
J13	\overline{TRST} Assert Time	t_{TRSTAT}	100.0	—	ns
J14	\overline{TRST} Setup Time (Negation) to TCLK High	t_{TRSTST}	10.0	—	ns

NOTES:

- ¹ MTMOD is expected to be a static signal. Hence, it is not associated with any timing

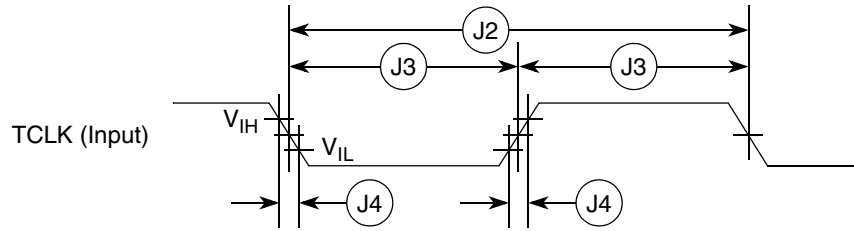

Figure 20. Test Clock Input Timing

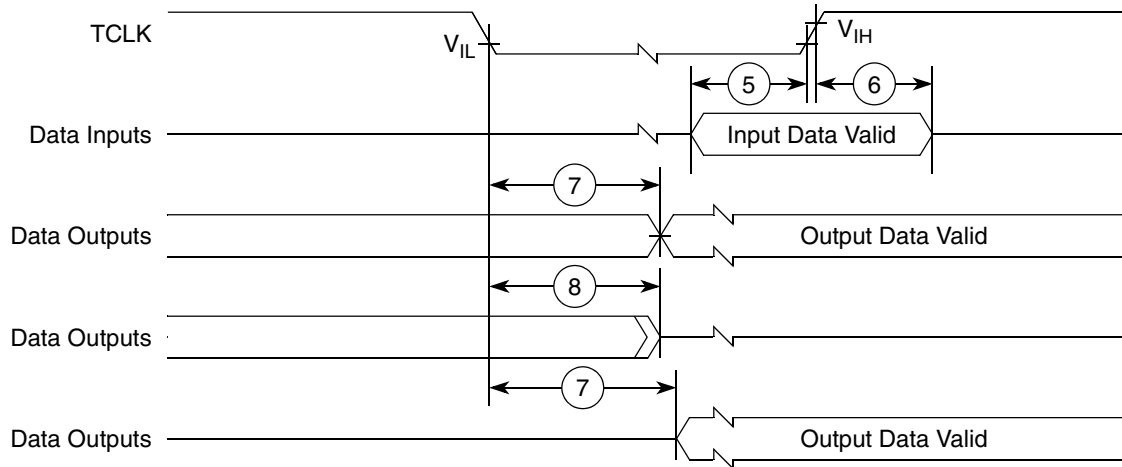

Figure 21. Boundary Scan (JTAG) Timing

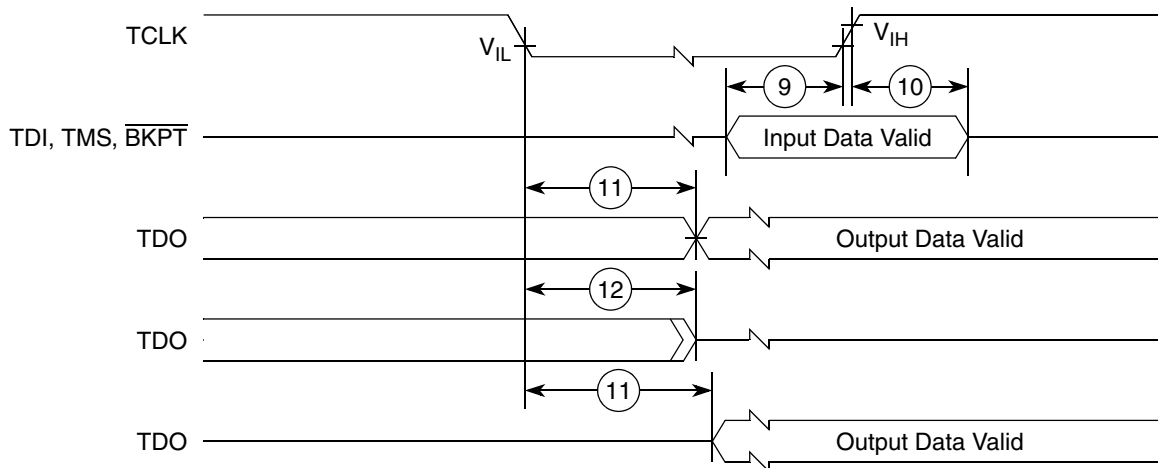

Figure 22. Test Access Port Timing

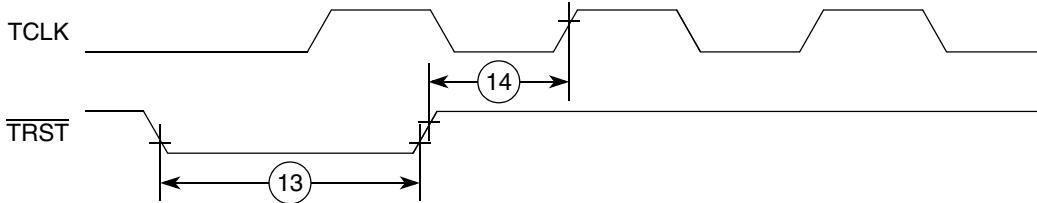

Figure 23. TRST Timing Debug AC Timing Specifications

Table 23 lists specifications for the debug AC timing parameters shown in Figure 25.

Table 23. Debug AC Timing Specification

Num	Characteristic	66 MHz		Units
		Min	Max	
D1	PSTDDATA to PSTCLK setup	4.5	—	ns
D2	PSTCLK to PSTDDATA hold	4.5	—	ns
D3	DSI-to-DSCLK setup	1	—	PSTCLKs
D4 ¹	DSCLK-to-DSO hold	4	—	PSTCLKs
D5	DSCLK cycle time	5	—	PSTCLKs

NOTES:

¹ DSCLK and DSI are synchronized internally. D4 is measured from the synchronized DSCLK input relative to the rising edge of CLKOUT.

Figure 24 shows real-time trace timing for the values in Table 23.

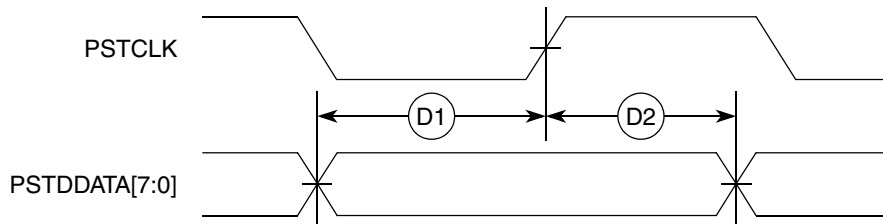

Figure 24. Real-Time Trace AC Timing

Figure 25 shows BDM serial port AC timing for the values in Table 23.

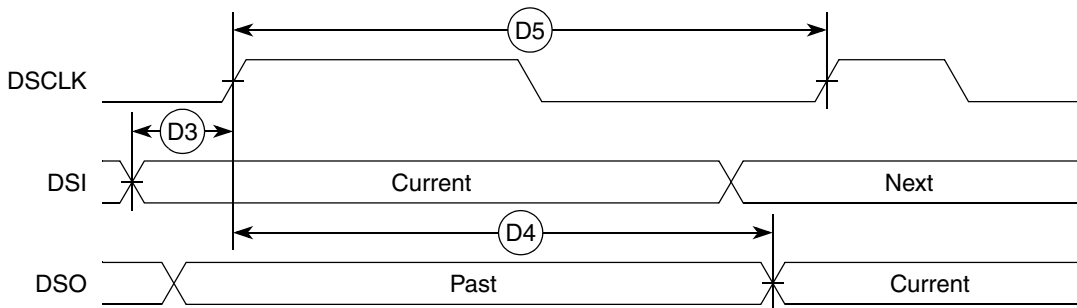

Figure 25. BDM Serial Port AC Timing

15 DSPI Electrical Specifications

Table 24 lists DSPI timings.

Table 24. DSPI Modules AC Timing Specifications

Name	Characteristic	Min	Max	Unit
DS1	DSPI_CS[3:0] to DSPI_CLK	$1 \times t_{ck}$	$510 \times t_{ck}$	ns
DS2	DSPI_CLK high to DSPI_DOUT valid.	—	12	ns
DS3	DSPI_CLK high to DSPI_DOUT invalid. (Output hold)	2	—	ns
DS4	DSPI_DIN to DSPI_CLK (Input setup)	10	—	ns
DS5	DSPI_DIN to DSPI_CLK (Input hold)	10	—	ns

The values in Table 24 correspond to Figure 26.

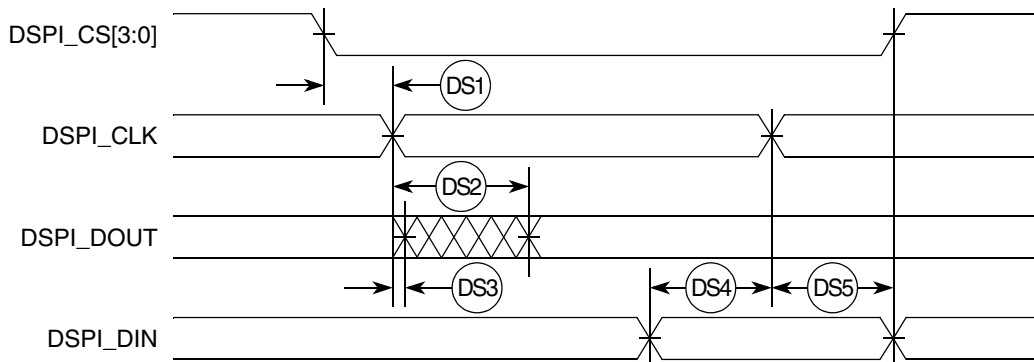

Figure 26. DSPI Timing

16 Timer Module AC Timing Specifications

Table 25 lists timer module AC timings.

Table 25. Timer Module AC Timing Specifications

Name	Characteristic	0–66 MHz		Unit
		Min	Max	
T1	TIN0 / TIN1 / TIN2 / TIN3 cycle time	3	—	PSTCLK
T2	TIN0 / TIN1 / TIN2 / TIN3 pulse width	1	—	PSTCLK

17 Revision History

Revision Number	Date	Substantive Changes
2.2	August 29, 2005	Table 7 : Changed C1 maximum spec from 33.3 ns to 40 ns.
2.3	August 30, 2005	Table 22 : Changed J11 maximum from 15 ns to 20 ns.
2.4	December 14, 2005	Table 10 : Changed FB1 maximum from 33.33 ns to 40 ns. Table 14 : Changed FB1 maximum from 33.33 ns to 40 ns.

THIS PAGE INTENTIONALLY LEFT BLANK

How to Reach Us:

Home Page:

www.freescale.com

E-mail:

support@freescale.com

USA/Europe or Locations Not Listed:

Freescale Semiconductor
Technical Information Center, CH370
1300 N. Alma School Road
Chandler, Arizona 85224
+1-800-521-6274 or +1-480-768-2130
support@freescale.com

Europe, Middle East, and Africa:

Freescale Halbleiter Deutschland GmbH
Technical Information Center
Schatzbogen 7
81829 Muenchen, Germany
+44 1296 380 456 (English)
+46 8 52200080 (English)
+49 89 92103 559 (German)
+33 1 69 35 48 48 (French)
support@freescale.com

Japan:

Freescale Semiconductor Japan Ltd.
Technical Information Center
3-20-1, Minami-Azabu, Minato-ku
Tokyo 106-0047, Japan
0120 191014 or +81 3 3440 3569
support.japan@freescale.com

Asia/Pacific:

Freescale Semiconductor Hong Kong Ltd.
Technical Information Center
2 Dai King Street
Tai Po Industrial Estate
Tai Po, N.T., Hong Kong
+800 2666 8080
support.asia@freescale.com

For Literature Requests Only:

Freescale Semiconductor Literature Distribution Center
P.O. Box 5405
Denver, Colorado 80217
1-800-441-2447 or 303-675-2140
Fax: 303-675-2150
LDCForFreescaleSemiconductor@hibbertgroup.com

RoHS-compliant and/or Pb- free versions of Freescale products have the functionality and electrical characteristics of their non-RoHS-compliant and/or non-Pb- free counterparts. For further information, see <http://www.freescale.com> or contact your Freescale sales representative.

For information on Freescale's Environmental Products program, go to <http://www.freescale.com/epp>.

Information in this document is provided solely to enable system and software implementers to use Freescale Semiconductor products. There are no express or implied copyright licenses granted hereunder to design or fabricate any integrated circuits or integrated circuits based on the information in this document.

Freescale Semiconductor reserves the right to make changes without further notice to any products herein. Freescale Semiconductor makes no warranty, representation or guarantee regarding the suitability of its products for any particular purpose, nor does Freescale Semiconductor assume any liability arising out of the application or use of any product or circuit, and specifically disclaims any and all liability, including without limitation consequential or incidental damages. "Typical" parameters that may be provided in Freescale Semiconductor data sheets and/or specifications can and do vary in different applications and actual performance may vary over time. All operating parameters, including "Typicals", must be validated for each customer application by customer's technical experts. Freescale Semiconductor does not convey any license under its patent rights nor the rights of others. Freescale Semiconductor products are not designed, intended, or authorized for use as components in systems intended for surgical implant into the body, or other applications intended to support or sustain life, or for any other application in which the failure of the Freescale Semiconductor product could create a situation where personal injury or death may occur. Should Buyer purchase or use Freescale Semiconductor products for any such unintended or unauthorized application, Buyer shall indemnify and hold Freescale Semiconductor and its officers, employees, subsidiaries, affiliates, and distributors harmless against all claims, costs, damages, and expenses, and reasonable attorney fees arising out of, directly or indirectly, any claim of personal injury or death associated with such unintended or unauthorized use, even if such claim alleges that Freescale Semiconductor was negligent regarding the design or manufacture of the part.



Freescale™ and the Freescale logo are trademarks of Freescale Semiconductor, Inc. All other product or service names are the property of their respective owners. © Freescale Semiconductor, Inc. 2004. All rights reserved.

MCF5475EC
Rev. 2.4
12/2005