



MCL101A–MCL101C

Vishay Semiconductors

Small Signal Schottky Barrier Diodes

Features

- Integrated protection ring against static discharge
- Low capacitance
- Low leakage current
- Low forward voltage drop

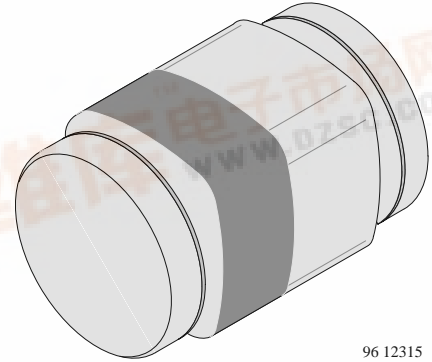

96 12315

Applications

HF–Detector
 Protection circuit
 Diode for low currents with a low supply voltage
 Small battery charger
 Power supplies
 DC / DC converter for notebooks

Order Instruction

Type	Type Differentiation	Ordering Code	Remarks
MCL101A	$V_R=60\text{ V}$, $V_F@I_F1\text{mA max. } 0.41\text{ V}$	MCL101A–TR	Tape and Reel
MCL101B	$V_R=50\text{ V}$, $V_F@I_F1\text{mA max. } 0.4\text{ V}$	MCL101B–TR	
MCL101C	$V_R=40\text{ V}$, $V_F@I_F1\text{mA max. } 0.39\text{ V}$	MCL101C–TR	

Absolute Maximum Ratings

$T_j = 25^\circ\text{C}$

Parameter	Test Conditions	Type	Symbol	Value	Unit
Reverse voltage		MCL101A	V_R	60	V
		MCL101B	V_R	50	V
		MCL101C	V_R	40	V
Peak forward surge current	$t_p=10\mu\text{s}$		I_{FSM}	2	A
Repetitive peak forward current			I_{FRM}	150	mA
Forward current			I_F	30	mA
Junction temperature			T_j	125	$^\circ\text{C}$
Storage temperature range			T_{stg}	-65...+150	$^\circ\text{C}$

Maximum Thermal Resistance

$T_j = 25^\circ\text{C}$

Parameter	Test Conditions	Symbol	Value	Unit
Junction ambient	on PC board 50 mmx50 mmx1.6 mm	R_{thJA}	320	K/W

MCL101A–MCL101C

Vishay Semiconductors



Electrical Characteristics

$T_j = 25^\circ\text{C}$

Parameter	Test Conditions	Type	Symbol	Min	Typ	Max	Unit
Reverse Breakdown Voltage	$I_R=10\mu\text{A}$	MCL101A	$V_{(BR)R}$	60			V
		MCL101B		50			V
		MCL101C		40			V
Leakage current	$V_R=50\text{ V}$	MCL101A	I_R			200	nA
	$V_R=40\text{ V}$	MCL101B				200	nA
	$V_R=30\text{ V}$	MCL101C				200	nA
Forward voltage drop	$I_F=1\text{mA}$	MCL101A	V_F			0.41	V
		MCL101B				0.4	V
		MCL101C				0.39	V
	$I_F=15\text{mA}$	MCL101A	V_F			1	V
		MCL101B				0.95	V
		MCL101C				0.9	V
Diode capacitance	$V_R=0\text{ V}, f=1\text{MHz}$	MCL101A	C_D			2.0	pF
		MCL101B				2.1	pF
		MCL101C				2.2	pF

Characteristics ($T_j = 25^\circ\text{C}$ unless otherwise specified)

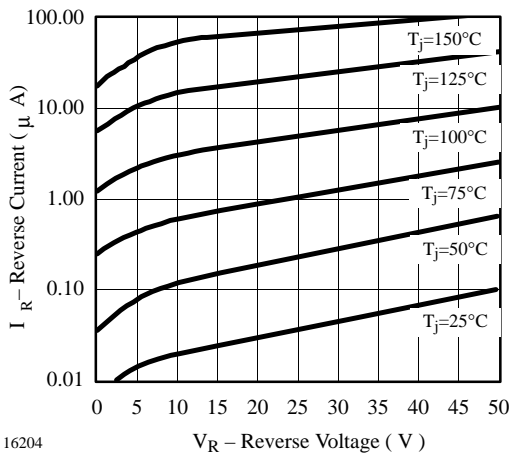

Figure 1. Reverse Current vs. Reverse Voltage

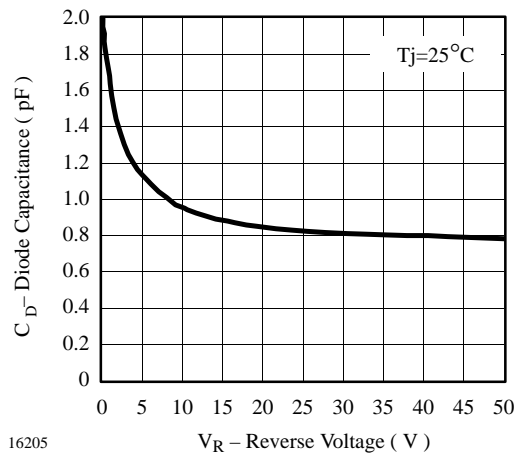
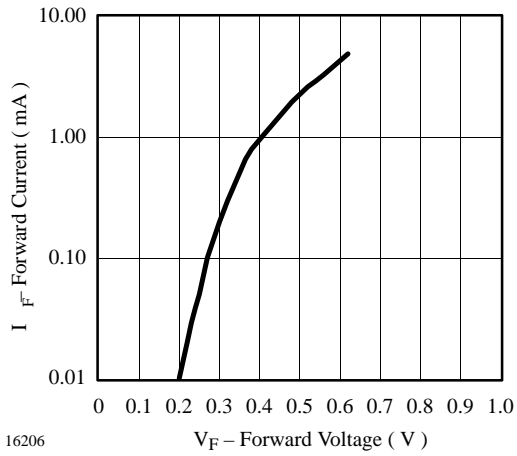

Figure 2. Diode Capacitance vs. Reverse Voltage



MCL101A–MCL101C

Vishay Semiconductors



16206

Figure 3. Forward Current vs. Forward Voltage

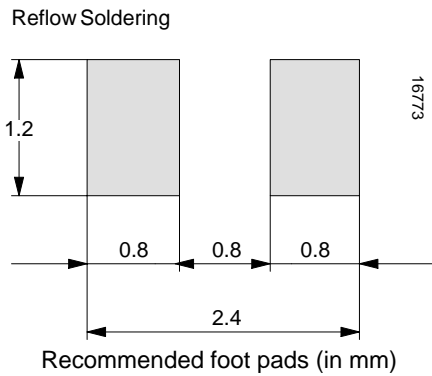
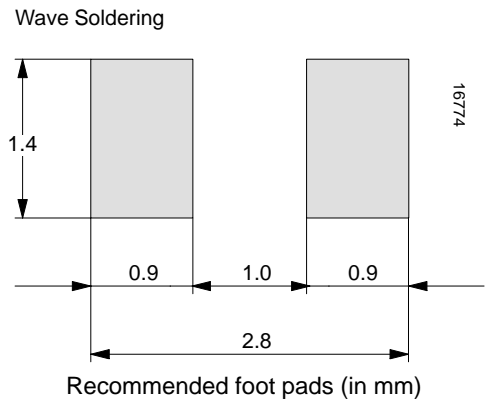

Dimensions in mm

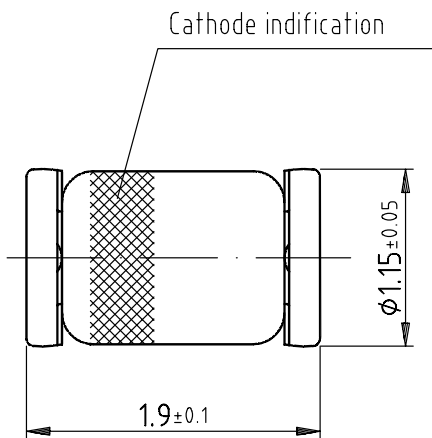

Glass case
Micro MELF

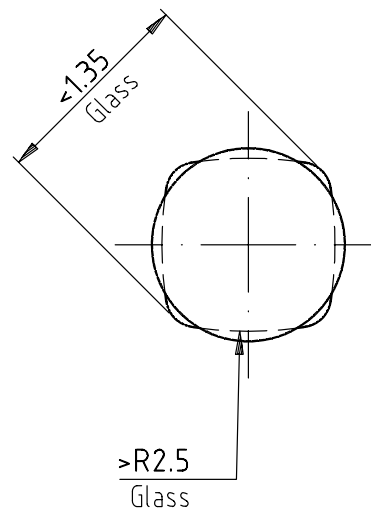

Drawing-No.: 6.560-5007.01-4
Issue: 5; 06.06.01

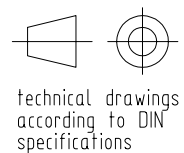

96 12072



Ozone Depleting Substances Policy Statement

It is the policy of **Vishay Semiconductor GmbH** to

1. Meet all present and future national and international statutory requirements.
2. Regularly and continuously improve the performance of our products, processes, distribution and operating systems with respect to their impact on the health and safety of our employees and the public, as well as their impact on the environment.

It is particular concern to control or eliminate releases of those substances into the atmosphere which are known as ozone depleting substances (ODSs).

The Montreal Protocol (1987) and its London Amendments (1990) intend to severely restrict the use of ODSs and forbid their use within the next ten years. Various national and international initiatives are pressing for an earlier ban on these substances.

Vishay Semiconductor GmbH has been able to use its policy of continuous improvements to eliminate the use of ODSs listed in the following documents.

1. Annex A, B and list of transitional substances of the Montreal Protocol and the London Amendments respectively
2. Class I and II ozone depleting substances in the Clean Air Act Amendments of 1990 by the Environmental Protection Agency (EPA) in the USA
3. Council Decision 88/540/EEC and 91/690/EEC Annex A, B and C (transitional substances) respectively.

Vishay Semiconductor GmbH can certify that our semiconductors are not manufactured with ozone depleting substances and do not contain such substances.

We reserve the right to make changes to improve technical design and may do so without further notice.

Parameters can vary in different applications. All operating parameters must be validated for each customer application by the customer. Should the buyer use Vishay-Semiconductors products for any unintended or unauthorized application, the buyer shall indemnify Vishay-Semiconductors against all claims, costs, damages, and expenses, arising out of, directly or indirectly, any claim of personal damage, injury or death associated with such unintended or unauthorized use.

Vishay Semiconductor GmbH, P.O.B. 3535, D-74025 Heilbronn, Germany
Telephone: 49 (0)7131 67 2831, Fax number: 49 (0)7131 67 2423