

**GENERAL
INSTRUMENT**

**HIGH-SPEED
TRANSISTOR OPTOCOUPLEDERS**

Optocouplers

**MCL2501 MCL2503 (HCPL-2503)
MCL2502 (HCPL-2502)
6N136 6N135**

MINIMUM CTR SELECTION CHART

	CTR @ $I_F = 8 \text{ mA}$		CTR @ $I_F = 16 \text{ mA}$	
	0-70°C	25°C	0-70°C	25°C
MCL 2501	14%	17%	17%	21%
MCL/HCPL-2503	11%	15%	9%	12%
6N136	—	—	15%	19%
6N135	—	—	5%	7%
MCL/HCPL-2502	—	—	—	15%–22% MAX

PROPAGATION DELAY COMPARISON

$I_F = 8 \text{ mA}$		$I_F = 16 \text{ mA}$	
0-70°C	25°C	0-70°C	25°C
MCL2501	MCL/ HCPL-2503	MCL2501	MCL/ HCPL-2502 6N136 6N135

PACKAGE DIMENSIONS

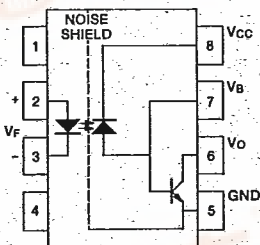
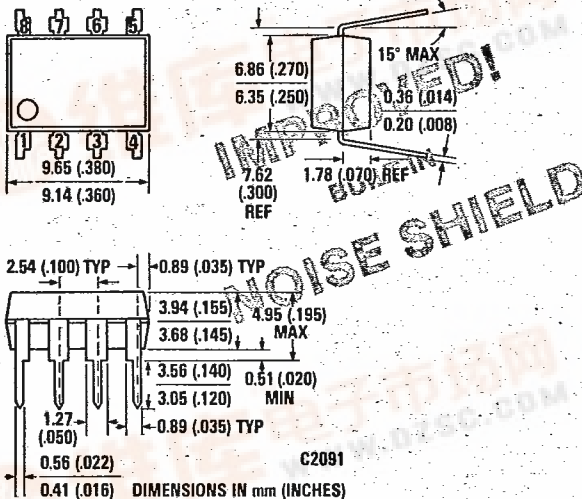

DESCRIPTION

The MCL2501, MCL/HCPL-2503/02 and 6N136/5 optocouplers contain a 700 nm GaAsP LED emitter, which is optically coupled to a high speed photodetector transistor.

A separate connection for the bias of the photodiode improves the speed by several orders of magnitude over conventional phototransistor optocouplers by reducing the base-collector capacitance of the input transistor.

An internal noise shield provides superior common mode rejection of 10 kV/ μ s. An improved package allows superior insulation permitting a 480 V working voltage compared to industry standard of 220 V.

The prime device in this family is MCL2501 which guarantees all DC parameters including CTR as well as all switching parameters over 0-70°C at both 8 mA and 16 mA input current.

FEATURES

- MCL2501 completely guaranteed 0-70°C at 8 and 16 mA.
- High Speed — 1 MBit/s
- Superior CMR — 10 kV/ μ s
- Superior insulation — 2500 V RMS 1 min
- Double working voltage — 480 V RMS
- CTR guaranteed 0-70°C
- U.L. recognized (File #E50151)

APPLICATIONS

- Line receivers
- Pulse transformer replacement
- Output interfact to CMOS-LSTTL-TTL
- Wide bandwidth analog coupling



MCL2501 MCL2503/2 (HCPL-2503/2) 6N136/5

3890128 GENL INSTR, OPTOELEK

88D 02910 D

ELECTRICAL CHARACTERISTICS ($T_A = 0^\circ\text{C}$ to 70°C Unless Otherwise Specified)

T-41-83

PARAMETER	SYMBOL	TEST CONDITIONS	MCL2501			MCL/HCPL-2503			MCL/HCPL-2502			UNITS
			MIN.	TYP.	MAX.	MIN.	TYP.	MAX.	MIN.	TYP.	MAX.	
Current transfer ratio	CTR	$I_F=16\text{mA}, V_O=0.4\text{V}, V_{CC}=4.5\text{V}, T_A=25^\circ\text{C}$	21	28		12	18		15		22	%
		$I_F=16\text{mA}, V_O=0.5\text{V}, V_{CC}=4.5\text{V}$	17			9						
		$I_F=8\text{mA}, V_O=0.5\text{V}, V_{CC}=4.5\text{V}, T_A=25^\circ\text{C}$	17	36		15						
		$I_F=8\text{mA}, V_O=0.5\text{V}, V_{CC}=4.5\text{V}$ Note 5, Fig. 1, 2	14			11						
Logic low output voltage	V_{OL}	$I_F=16\text{mA}, I_O=1.1\text{mA}, V_{CC}=4.5\text{V}$					0.2	0.5				V
		$I_F=16\text{mA}, I_O=2.4\text{mA}, V_{CC}=4.5\text{V}$		0.1	0.4					0.1	0.4	
		$I_F=8\text{mA}, I_O=0.7\text{mA}, V_{CC}=4.5\text{V}$		0.2	0.5		0.2	0.5				
Logic high output current	I_{OH}	$I_F=0\text{mA}, V_O=V_{CC}=5.5\text{V}, T_A=25^\circ\text{C}$.003	.5	μA
		$I_F=0\text{mA}, V_O=V_{CC}=15\text{V}, T_A=25^\circ\text{C}$		0.01	1					0.01	1	
		$I_F=0\text{mA}, V_O=V_{CC}=15\text{V}$ Fig. 7			50						50	
Logic low supply current	I_{CCL}	$I_F=16\text{mA}, V_O=\text{Open}, V_{CC}=15\text{V}$								40		μA
		$I_F=8\text{mA}, V_O=\text{Open}, V_{CC}=5.5\text{V}$		20			20					
Logic high supply current	I_{CCH}	$I_F=0\text{mA}, V_O=\text{Open}, V_{CC}=15\text{V}, T_A=25^\circ\text{C}$		0.02	1					0.02	1	μA
		$I_F=0\text{mA}, V_O=\text{Open}, V_{CC}=15\text{V}$			2						2	
Input forward voltage	V_F	$I_F=16\text{mA}, T_A=25^\circ\text{C}$		1.5	1.7		1.5	1.7		1.5	1.7	V
		$I_F=8\text{mA}, T_A=25^\circ\text{C}$ Fig. 3		1.5	1.7		1.5	1.7				
Input reverse breakdown voltage	BV_R	$I_F=10\mu\text{A}, T_A=25^\circ\text{C}$	5			5			5			V
Temp. coefficient of forward voltage	V_F	$I_F=16\text{mA}$		-1.6			-1.6			-1.6		$\text{mV}/^\circ\text{C}$
Input-Output insulation leakage	I_{I-O}	45% Relative Humidity $t=5\text{sec}$ $V_{I-O}=3000\text{V}_{DC}, T_A=25^\circ\text{C}$ Note 6		—			—			—		μA
Withstand insulation test voltage	V_{ISO}	$\text{RH} \leq 50\% t=1\text{min}$ $T_A=25^\circ\text{C}$ Notes 6, 11, 12	2500			2500			2500			V RMS
Resistance (Input-Output)	R_{I-O}	$V_{I-O}=500\text{V}_{DC}$ Note 6		10^{12}			10^{12}			10^{12}		Ω
Capacitance (Input-Output)	C_{I-O}	$F=1\text{MHz}$ Note 6		0.6			0.6			0.6		pF
DC current gain	h_{FE}	$I_O=3\text{mA}, V_O=5\text{V}$		150			150			150		—

All typical values are at $T_A=25^\circ\text{C}$

ELECTRICAL CHARACTERISTICS ($T_A = 0^\circ\text{C}$ to 70°C Unless Otherwise Specified)

T-41-83

PARAMETER	SYMBOL	TEST CONDITIONS	6N136			6N135			UNITS
			MIN.	TYP.	MAX.	MIN.	TYP.	MAX.	
Current transfer ratio	CTR	$I_F=16\text{mA}, V_O=0.4\text{V}, V_{CC}=4.5\text{V}, T_A=25^\circ\text{C}$	*19	24		*7	18		%
		$I_F=16\text{mA}, V_O=0.5\text{V}, V_{CC}=4.5\text{V}$	15			5			
		$I_F=8\text{mA}, V_O=0.5\text{V}, V_{CC}=4.5\text{V}, T_A=25^\circ\text{C}$							
		$I_F=8\text{mA}, V_O=0.5\text{V}, V_{CC}=4.5\text{V}$ Note 5, Fig. 1.2							
Logic low output voltage	V_{OL}	$I_F=16\text{mA}, I_O=1.1\text{mA}, V_{CC}=4.5\text{V}$				0.1	0.4		V
		$I_F=16\text{mA}, I_O=2.4\text{mA}, V_{CC}=4.5\text{V}$		0.1	0.4				
		$I_F=8\text{mA}, I_O=0.7\text{mA}, V_{CC}=4.5\text{V}$							
Logic high output current	I_{OH}	$I_F=0\text{mA}, V_O=V_{CC}=5.5\text{V}, T_A=25^\circ\text{C}$.003	*.5	.003	*.5		μA
		$I_F=0\text{mA}, V_O=V_{CC}=15\text{V}, T_A=25^\circ\text{C}$		0.01	1	0.01	1		
		$I_F=0\text{mA}, V_O=V_{CC}=15\text{V}$ Fig. 7			50		50		
Logic low supply current	I_{CCL}	$I_F=16\text{mA}, V_O=\text{Open}, V_{CC}=15\text{V}$		40		40		μA	
		$I_F=8\text{mA}, V_O=\text{Open}, V_{CC}=5.5\text{V}$							
Logic high supply current	I_{CCH}	$I_F=0\text{mA}, V_O=\text{Open}, V_{CC}=15\text{V}, T_A=25^\circ\text{C}$		0.02	*1	0.02	*1	μA	
		$I_F=0\text{mA}, V_O=\text{Open}, V_{CC}=15\text{V}$			2		2		
Input forward voltage	V_F	$I_F=16\text{mA}, T_A=25^\circ\text{C}$		1.5	1.7	1.5	1.7	V	
		$I_F=8\text{mA}, T_A=25^\circ\text{C}$ Fig. 3							
Input reverse breakdown voltage	BV_R	$I_F=10\mu\text{A}, T_A=25^\circ\text{C}$	*5			*5		V	
Temp. coefficient of forward voltage	V_F	$I_F=16\text{mA}$		-1.6		-1.6		$\text{mV}/^\circ\text{C}$	
Input-Output insulation leakage	I_{I-O}	45% Relative Humidity $t=5\text{sec}$ $V_{I-O}=3000V_{DC}, T_A=25^\circ\text{C}$ Note 6			*1.0		*1.0	μA	
Withstand insulation test voltage	V_{ISO}	$RH \leq 50\% t = 1\text{min}$ $T_A=25^\circ\text{C}$ Notes 6, 11, 12	2500			2500		V RMS	
Resistance (Input-Output)	R_{I-O}	$V_{I-O}=500V_{DC}$ Note 6		10^{12}		10^{12}		Ω	
Capacitance (Input-Output)	C_{I-O}	$F=1\text{MHz}$ Note 6		0.6		0.6		pF	
DC current gain	h_{FE}	$I_O=3\text{mA}, V_O=5\text{V}$		150		150		—	

*JEDEC Registered Data
All typical values are at $T_A=25^\circ\text{C}$

SWITCHING CHARACTERISTICS ($T_A = 25^\circ\text{C}$ Unless Otherwise Specified) $V_{CC} = 5.0\text{V}$

PARAMETER	SYMBOL	TEST CONDITIONS	MCL2501			MCL/HCPL-2503			MCL/HCPL-2502			UNITS
			MIN.	TYP.	MAX.	MIN.	TYP.	MAX.	MIN.	TYP.	MAX.	
Propagation delay time to logic low at output	t_{PHL}	$I_F=16\text{mA}, R_L=4.1\text{K}$										μs
		$I_F=16\text{mA}, R_L=1.9\text{K}$.35	0.8		
		$I_F=16\text{mA}, R_L=1.9\text{K}, 0-70^\circ\text{C}$.35	0.8							
		$I_F=16\text{mA}, R_L=4.7\text{K}$					0.4	1.5				
		$I_F=8\text{mA}, R_L=7.5\text{K}$					1.0	1.5				
		$I_F=8\text{mA}, R_L=7.5\text{K}, 0-70^\circ\text{C}$ Notes 8, 9 Fig. 12		.8	1.5							
Propagation delay time to logic high at output	t_{PLH}	$I_F=16\text{mA}, R_L=4.1\text{K}$.25	0.8	μs
		$I_F=16\text{mA}, R_L=1.9\text{K}$										
		$I_F=16\text{mA}, R_L=1.9\text{K}, 0-70^\circ\text{C}$.20	.35							
		$I_F=16\text{mA}, R_L=4.7\text{K}$					1.5	2.5				
		$I_F=8\text{mA}, R_L=7.5\text{K}$					1.5	2.5				
		$I_F=8\text{mA}, R_L=7.5\text{K}, 0-70^\circ\text{C}$ Notes 8, 9 Fig. 12		.80	1.30							
Common mode transient immunity at logic high output level	CM_H	$V_{CM}=10V_p, R_L=4.1\text{K}$										$V/\mu\text{s}$
		$V_{CM}=10V_p, R_L=1.9\text{K}$								10K		
		$V_{CM}=10V_p, R_L=4.7\text{K}$						10K				
		$V_{CM}=50V_p, R_L=1.9\text{K}$ Notes 7, 8, 9 Fig. 11	1K	10K								
Common mode transient immunity at logic low output level	CM_L	$V_{CM}=10V_p, R_L=4.1\text{K}$										$V/\mu\text{s}$
		$V_{CM}=10V_p, R_L=1.9\text{K}$								-10K		
		$V_{CM}=10V_p, R_L=4.7\text{K}$						-10K				
		$V_{CM}=50V_p, R_L=1.9\text{K}$ Notes 7, 8, 9 Fig. 11	-1K	-10K								
Bandwidth	BW	$R_L=100$ Note 10 Fig. 10		3			2			2		MHz

*JEDEC Registered Data

ABSOLUTE MAXIMUM RATINGS†

Storage temperature -55°C to 125°C
 Operating temperature -55°C to 100°C
 Lead solder temperature 260°C for 10s
 Average forward input current 25 mA (1)
 Peak forward input current 50 mA (2)
 (50% duty cycle, 1ms P.W.)
 Peak transient input current - I_F 1.0 A
 ($\leq 1 \mu\text{s}$ P.W., 300 pps)

Reverse input voltage 5 V
 Input power dissipation 45 mW (3)
 Average output current 8 mA
 Peak output current 16 mA
 Emitter-base reverse voltage 5 V
 Supply and output voltage -0.5V to 15 V
 Base current 5 mA
 Output power dissipation 100 mW(4)

†Absolute Maximum Ratings are JEDEC Registered Data for 6N136 and 6N135.
 6N136 and 6N135 are the only JEDEC Registered Parts on this data sheet.

SWITCHING CHARACTERISTICS ($T_A = 25^\circ\text{C}$ Unless Otherwise Specified) $V_{CC} = 5.0\text{ V}$

Optocouplers

PARAMETER	SYMBOL	TEST CONDITIONS	6N136			6N135			UNITS
			MIN.	TYP.	MAX.	MIN.	TYP.	MAX.	
Propagation delay time to logic low at output	t_{PHL}	$I_F = 16\text{mA}, R_L = 4.1\text{K}$					0.5	*1.5	μs
		$I_F = 16\text{mA}, R_L = 1.9\text{K}$		0.35	*0.8				
		$I_F = 16\text{mA}, R_L = 1.9\text{K}$							
		$I_F = 16\text{mA}, R_L = 4.7\text{K}$							
		$I_F = 8\text{mA}, R_L = 7.5\text{K}$							
		$I_F = 8\text{mA}, R_L = 7.5\text{K}$ Notes 8, 9 Fig. 12							
Propagation delay time to logic high at output	t_{PLH}	$I_F = 16\text{mA}, R_L = 4.1\text{K}$					0.4	*1.5	μs
		$I_F = 16\text{mA}, R_L = 1.9\text{K}$.25	*0.8				
		$I_F = 106\text{mA}, R_L = 1.9\text{K}$							
		$I_F = 16\text{mA}, R_L = 4.7\text{K}$							
		$I_F = 8\text{mA}, R_L = 7.5\text{K}$							
		$I_F = 8\text{mA}, R_L = 7.5\text{K}$ Notes 8, 9 Fig. 12							
Common mode transient immunity at logic high output level	CM_H	$V_{CM} = 10\text{V}_p, R_L = 4.1\text{K}$				1K	10K		$\text{V}/\mu\text{s}$
		$V_{CM} = 10\text{V}_p, R_L = 1.9\text{K}$	1K	10K					
		$V_{CM} = 10\text{V}_p, R_L = 4.7\text{K}$							
		$V_{CM} = 50\text{V}_p, R_L = 1.9\text{K}$ Notes 7, 8, 9 Fig. 11	1K	10K					
Common mode transient immunity at logic low output level	CM_L	$V_{CM} = 10\text{V}_p, R_L = 4.1\text{K}$				-1K	-10K		$\text{V}/\mu\text{s}$
		$V_{CM} = 10\text{V}_p, R_L = 1.9\text{K}$	-1K	-10K					
		$V_{CM} = 10\text{V}_p, R_L = 4.7\text{K}$							
		$V_{CM} = 50\text{V}_p, R_L = 1.9\text{K}$ Notes 7, 8, 9 Fig. 11	-1K	-10K					
Bandwidth	BW	$R_L = 100$ Note 10 Fig. 10		2			2		MHz

*JEDEC Registered Data

NOTES:

- Derate linearly above 70°C free-air temperature at a rate of $0.8\text{ mA}/^\circ\text{C}$.
- Derate linearly above 70°C free-air temperature at a rate of $1.6\text{ mA}/^\circ\text{C}$.
- Derate linearly above 70°C free-air temperature at a rate of $0.9\text{ mW}/^\circ\text{C}$.
- Derate linearly above 70°C free-air temperature at a rate of $1.0\text{ mW}/^\circ\text{C}$.
- CURRENT TRANSFER RATIO is defined as the ratio of output collector current, I_O , to the forward LED input current, I_F , times 100%.
- Device considered a two-terminal device: Pins 1, 2, 3, and 4 shorted together and Pins 5, 6, 7, and 8 shorted together.
- Common mode transient immunity in Logic High level is the maximum tolerable (positive) dV_{CM}/dt on the leading edge of the common mode pulse V_{CM} , to assure that the output will remain in a Logic High state (i.e., $V_O > 2.0\text{ V}$). Common mode transient immunity in Logic Low level is the maximum tolerable (negative) dV_{CM}/dt on the trailing edge of the common mode pulse signal, V_{CM} , to assure that the output will remain in a Logic Low state (i.e., $V_O < 0.8\text{ V}$).
- The $4.1\text{ K}\Omega$ load represents 1 LSTTL unit load of 0.36 mA and $6.1\text{ K}\Omega$.
- The $1.9\text{ K}\Omega$ load represents 1 TTL unit load of 1.6 mA and the $5.6\text{ K}\Omega$ pull-up resistor.
- The frequency at which the ac output voltage is 3 dB below the low frequency asymptote.
- This is a proof test to validate the UL440 VAC rating.
- The $2500\text{ Vac}/1\text{ min}$ capability is validated by a factory $3.1\text{ K Vac (rms)}/1\text{ sec}$ dielectric voltage withstand test.

TYPICAL CHARACTERISTIC CURVES ($T_A = 25^\circ\text{C}$ Unless Otherwise Specified)

T-41-83

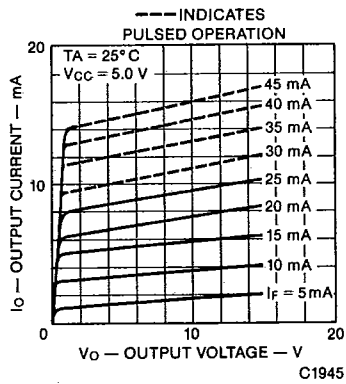

Fig. 1. DC and Pulsed Transfer Characteristics

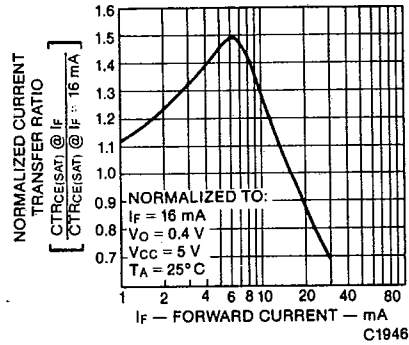

Fig. 2. Normalized Current Transfer Ratio vs. Forward Current

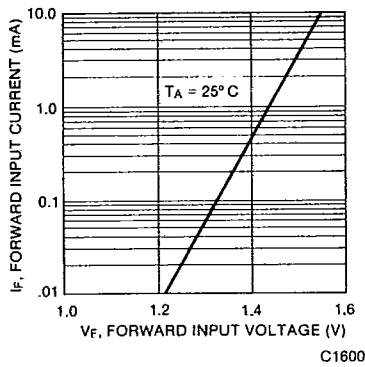

Fig. 3. Forward Input Current vs. Forward Input Voltage

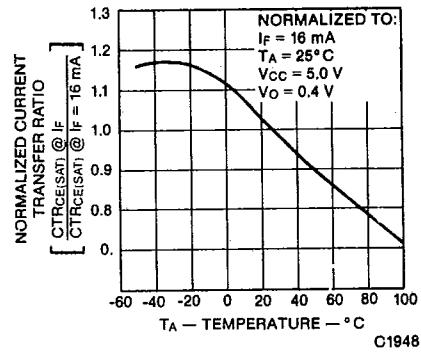

Fig. 4. Normalized Current Transfer Ratio vs. Temperature

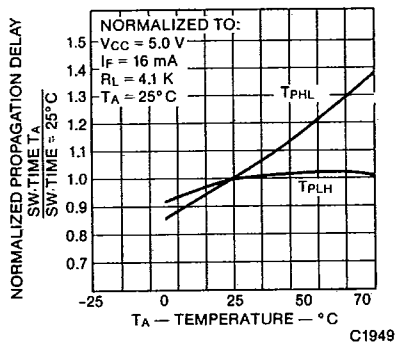

Fig. 5. Normalized Propagation Delay vs. Temperature at $I_F = 16$ mA

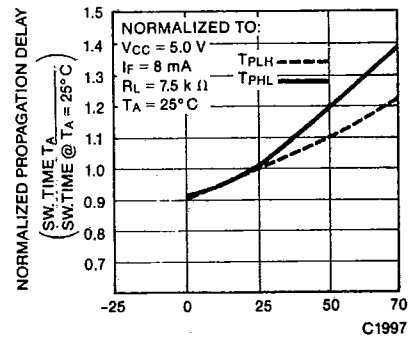

Fig. 6. Normalized Propagation Delay vs. Temperature at $I_F = 8$ mA

TYPICAL CHARACTERISTIC CURVES ($T_A = 25^\circ\text{C}$ Unless Otherwise Specified)

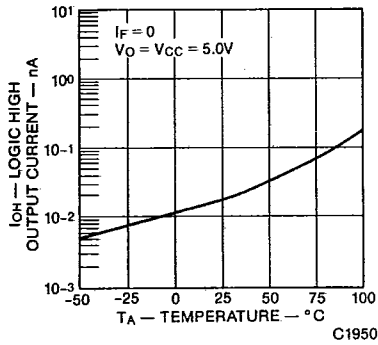

Fig. 7. Logic High Output Current vs. Temperature

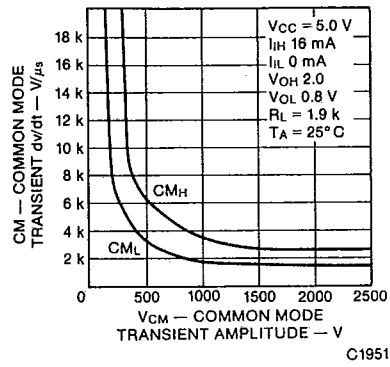

Fig. 8. Common Mode Transient Immunity vs. Common Mode Transient Amplitude

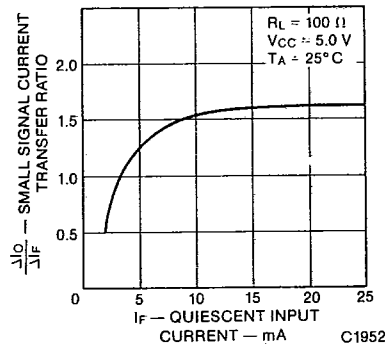

Fig. 9. Small Signal Transfer Ratio vs. Quiescent Input Current

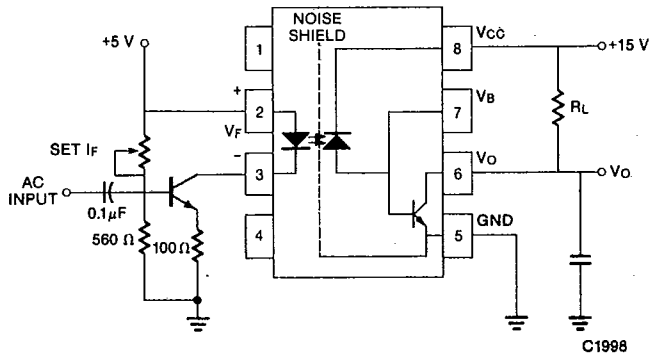
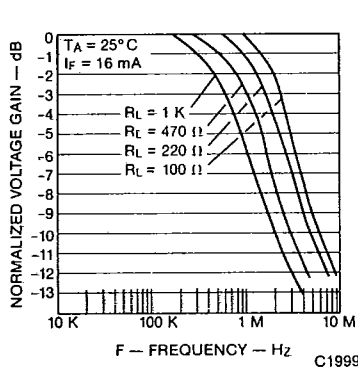

Fig. 10. Frequency Response

TYPICAL CHARACTERISTIC CURVES ($T_A = 25^\circ\text{C}$ Unless Otherwise Specified)

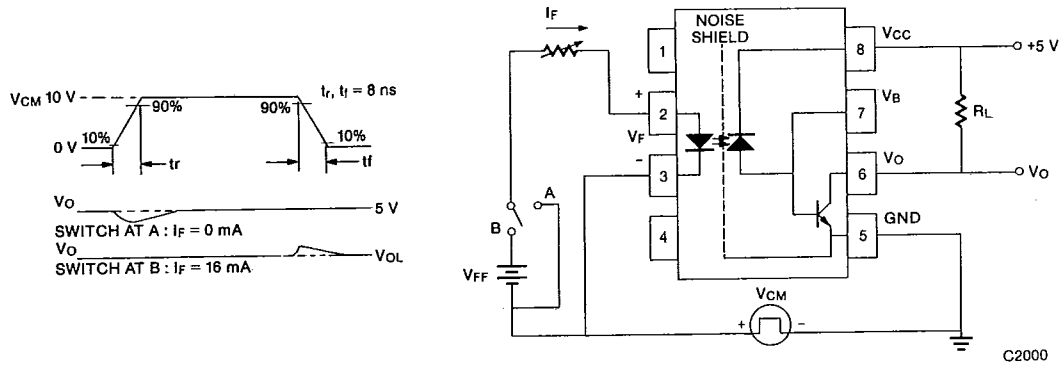

Fig. 11. Test Circuit for Transient Immunity and Typical Waveforms

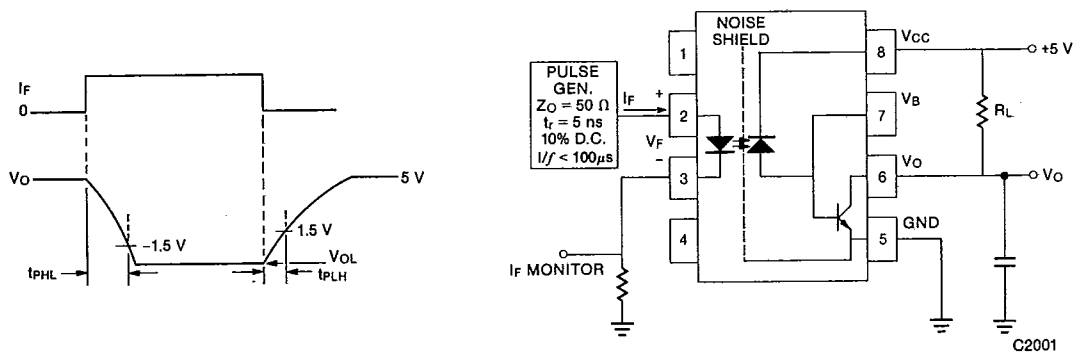

Fig. 12. Switching Test Circuit