

SIEMENS

MDL 2416C T-41-37
MDL 2416TXV
MDL 2416TXVB

**.15" Red, 4-Digit, 16 Segment plus Decimal
 HI-REL/Military Alphanumeric Intelligent Display®
 with Memory/Decoder/Driver**

Intelligent
Display Devices

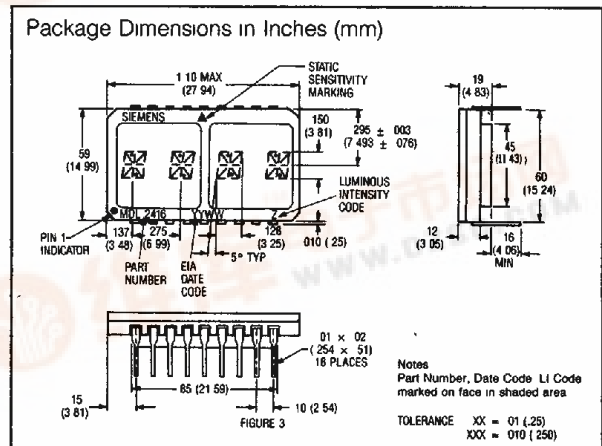
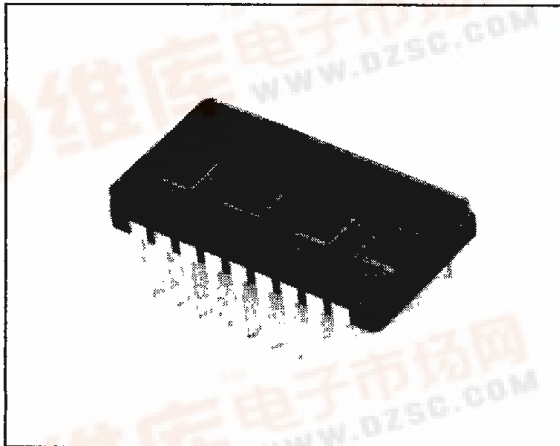

FEATURES

- 150 Mil High, Non-Magnified Monolithic Character
- Rugged Ceramic Package, Hermetically Sealed Flat Glass Window
- Low Profile Package
- Dual in Line Configuration
- Close Vertical Row Spacing, .600 Inches
- 100 Mil Pin Spacing
- Wide Viewing Angle
- Wide Temperature Operating Range, -55°C to +100°C
- Fully Integrated CMOS Drive Electronics
- Direct Access to Each Digit Independently and Asynchronously
- TTL Compatible, 5 Volt Power Supply
- Independent Cursor Function
- 17th Segment for Improved Punctuation Marks
- Two Chip Enables
- Interdigit Blanking
- Display Blank Function
- Memory Clear Function
- End-Stackable, Four Character Package
- Intensity Coded for Display Uniformity
- TXVB Process Conforms to MIL-D-87157 Quality Level A Test and Tables I, II, IIIa and IV
- TXV Process Conforms to a Modified MIL-D-87157 Quality Level A Test and Table I

DESCRIPTION

The MDL 2416 is a military alphanumeric four digit display having a 17 segment font and built-in CMOS drive circuitry that is TTL and microprocessor compatible. The integrated circuit contains memory, ASCII ROM decoder, multiplexing circuitry, and drivers. The MDL 2416 is designed for use in extremely harsh environments where only the most reliable product is acceptable.

Data entry is asynchronous and can be random. A display system can be built using any number of MDL 2416s since each digit of any MDL 2416 can be addressed independently and will continue to display the character last stored until replaced by another.

System interconnection is straightforward. The least significant two address bits (A₀, A₁) are normally connected to the like named inputs of all MDL 2416s in the system. With two chips enables, (CE₁, CE₂), four MDL 2416s (16 characters) can easily be interconnected without an external decoder.

Important: Since this is a CMOS device, normal precautions should be taken to avoid static damage.



OPTOELECTRONIC CHARACTERISTICS @ 25°C

T-41-37

ABSOLUTE MAXIMUM RATINGS	
DC Supply	-0.5 to +6.0 VDC
Input Voltage Relative to Gnd (all inputs)	-0.5 to V _{CC} + 0.5 VDC
Operating temperature	-55 to +100°C
Storage temperature	-65 to +125°C

OPTICAL CHARACTERISTICS	
Spectral Peak Wavelength	660 nm typ
Spectral Line Half-Width	40 nm typ
Viewing Angle (Note 1)	±50°
Digit Size	15 in
Luminous Intensity (Typ)	0.1 mcd/seg @ V _{CC} = 5V
Intensity matching, Seg to Seg	1.8:1 @ V _{CC} = 5V

DC CHARACTERISTICS @25°C

Parameter	Min.	Typ.	Max.	Units	Conditions
V _{CC}	4.5	5.0	5.5	V	25°C
I _{CC} (Blank) (1)	0.10	1.5	4.0	mA	V _{CC} = 5 V, $\overline{WR} = V_{CC}$, V _{IN} = 0 V All other pins
I _{CC} (10 segments/char. 4 digits on)	65	85	115	mA	V _{CC} = 5 V
I _{CC} (all segments on cursor in 4 digits) (1, 2)	85	120	165	mA	V _{CC} = 5 V Measured at 5 sec, 60 sec max.
V _{IL} (all inputs)			0.8	V	V _{CC} = 5 V ± 0.5 V
V _{IH} (all inputs)	2.0			V	V _{CC} = 5 V ± 0.5 V
I _{IL} (all inputs)		60	160	μA	V _{CC} = 5 V, V _{IN} = 0.8 V

1 Measured at 5 sec
2 60 sec max. duration.

AC CHARACTERISTICS

Parameter	Symbol	-55°C (ns)	+25°C (ns)	+100°C (ns)
Chip Enable Set Up Time	T _{CES}	190	275	410
Address Set Up Time	T _{AS}	190	275	410
Cursor Set Up Time	T _{CUS}	190	275	410
Chip Enable Hold Time	T _{CEH}	25	25	25
Address Hold Time	T _{AH}	25	25	25
Cursor Hold Time	T _{CUH}	25	25	25
Write Delay Time	T _{WD}	40	50	60
Write Pulse	T _W	150	225	350
Data Set Up Time	T _{DS}	100	150	300
Data Hold Time	T _{DH}	25	25	25
Clear	T _{CLR}	12 ms	15 ms	17.5 ms

TIMING CHARACTERISTICS
WRITE CYCLE WAVEFORMS

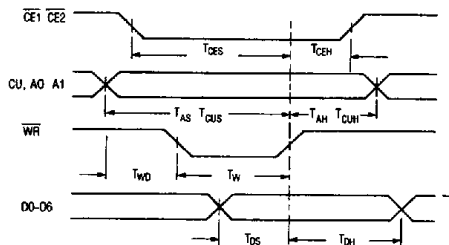

TIMING MEASUREMENT VOLTAGE LEVELS

The diagram shows a trapezoidal pulse representing a timing measurement. The voltage levels are marked as 4 VOLTS (top), 2 VOLTS (middle), and 0 VOLTS (bottom).

(for tester calibration only)

- Notes
- "Off Axis Viewing Angle" is here defined as "the minimum angle in any direction from the normal to the display surface at which any part of any segment in the display is not visible"
 - This display contains a CMOS integrated circuit. Normal CMOS handling precautions should be taken to avoid damage due to high static voltages or electric fields. SEE APPNOTE 18
 - Unused inputs must be tied to an appropriate logic voltage level (either V+ or V-)

TOP VIEW

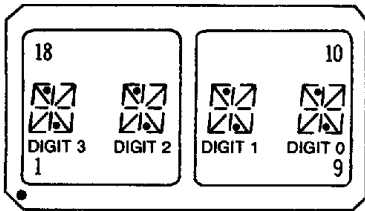

Pin	Function	Pin	Function
1	$\overline{CE1}$ Chip Enable	18	\overline{BL} Display Blank
2	$\overline{CE2}$ Chip Enable	17	D4 Data input
3	\overline{CLR} Clear	16	D5 Data input
4	CUE Cursor Enable	15	D6 Data input
5	\overline{CU} Cursor Select	14	D3 Data input
6	\overline{WR} Write	13	D2 Data input
7	A1 Digit Select	12	D1 Data input
8	A0 Digit Select	11	D0 Data input
9	V _{CC}	10	GND

PIN DEFINITIONS

- | | | | |
|-----------------------------------|---|------------------|---|
| V _{CC} | Positive power supply | A1 | Next to least significant address bit |
| Gnd | Negative power supply | \overline{CU} | Cursor load control which must be held high to store data in the RAM and low to store data in the cursor memory |
| D0 thru D6 | Data inputs, D0 is the least significant data input and D6 is the most significant data input | CUE | Cursor function control, displays the cursor in any positions having an "on" in cursor memory |
| \overline{WR} | Write input which must be held low to write data into memory | \overline{CLR} | An input which clears the RAM when held low for 15ms |
| $\overline{CE1}$ $\overline{CE2}$ | Two chip enable inputs which must be held low to enable the chip | \overline{BL} | Blanking input. Turns off all segments when held low. Does not affect RAM or cursor memory contents |
| A0 | Least significant address bit | | |

CHARACTER SET

D6	D5	D4	hex	0	1	2	3	4	5	6	7	8	9	A	B	C	D	E	F
L	H	L	2		!	"	#	\$	%	&	'	<	>	*	+	,	--	.	/
L	H	H	3	0	1	2	3	4	5	6	7	8	9	:	;	<	=	>	?
H	L	L	4	Q	R	S	T	U	V	W	X	Y	Z	[]	^	_		
H	L	H	5	P	Q	R	S	T	U	V	W	X	Y	Z	[\]	^	_

All other input codes display "blank"

FUNCTIONAL DESCRIPTION

Referring to the block diagram

Display Memory—consists of a 4 by 7-bit RAM block. Each 7-bit location holds the 7-bit ASCII data for the four displays.

Cursor Memory—holds the cursor data for all the displays.

ROM—has a look-up table for the 64 characters.

Oscillator Logic—provides all the necessary timing.

Display Drivers—17 segment drivers and 4 digit drivers.

LED Displays—each display is comprised of 16 segments and one decimal point which make up the alphanumeric characters.

BLOCK DIAGRAM

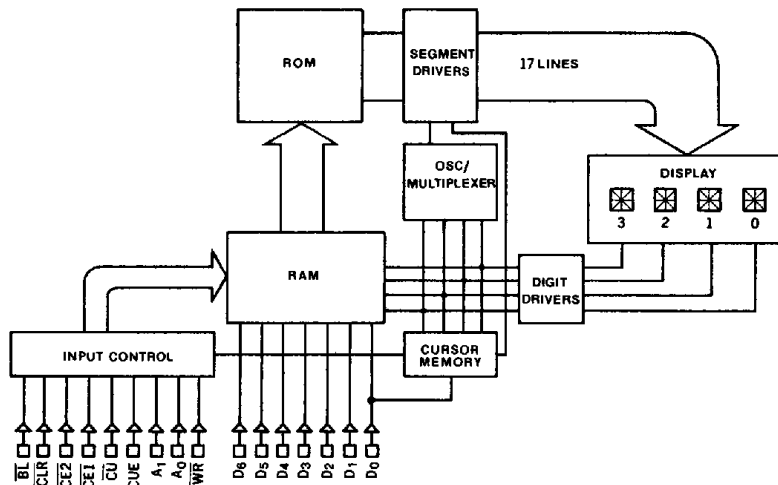

TYPICAL SCHEMATIC FOR 16 DIGIT SYSTEM

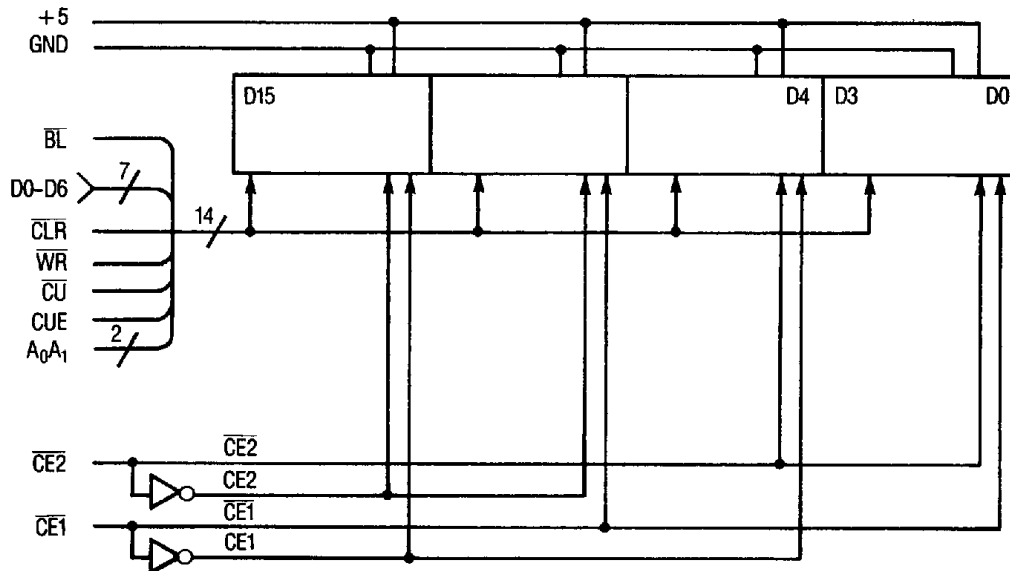

LOADING DATA

Setting the chip enable ($\overline{CE1}$, $\overline{CE2}$) to their true state will enable data loading. The desired data code (D0-D6) and digit address (A_0 , A_1) must be held stable during the write cycle for storing new data

Data entry may be asynchronous and random (Digit 0 is defined as a right hand digit with $A_1=A_0=0$)

Clearing of the entire internal four-digit memory can be accomplished by holding the clear (\overline{CLR}) low for one complete display multiplex cycle, 15 mS minimum. The clear function will clear both the ASCII RAM and the cursor RAM. Loading an illegal data code will display a blank

LOADING CURSOR

Setting the chip enables ($\overline{CE1}$, $\overline{CE2}$) and cursor select (\overline{CU}) to their true state will enable cursor loading. A write (\overline{WR}) pulse will now store or remove a cursor into the digit location addressed by A_0 , A_1 ; as defined in data entry. A cursor will be stored if $D0=1$, and will be removed if $D0=0$. The cursor (\overline{CU}) pulse width should not be less than the write (\overline{WR}) pulse or erroneous data may appear in the display

For those users not requiring the cursor, the cursor enable signal (CUE) may be tied low to disable the display of the cursor function. A flashing cursor can be realized by simply pulsing CUE. If the cursor has been loaded to any or all positions in the display, then CUE will control whether the cursor(s) or the characters appear. CUE does not affect the contents of cursor memory

DISPLAY BLANKING

Blanking the display may be accomplished by loading a blank or space into each digit of the display or by using the (\overline{BL}) display blank input.

Setting the (\overline{BL}) input low does not affect the contents of either data or cursor memory. A flashing display can be realized by pulsing (\overline{BL})

The display can be dimmed by pulse width modulating the (\overline{BL}) at a frequency sufficiently fast to not interfere with the internal clock. Experimentation is encouraged, although 4.5 KHz square wave on the (\overline{BL}) pin will have no effect on display brightness. As the low state duty factor is increased, the display will dim, not affecting other device functions.

TYPICAL LOADING DATA STATE TABLE

CONTROL							ADDRESS		DATA							DISPLAY DIGIT			
\overline{BL}	$\overline{CE1}$	$\overline{CE2}$	CUE	\overline{CU}	\overline{WR}	\overline{CLR}	A1	A0	D6	D5	D4	D3	D2	D1	D0	3	2	1	0
H	X	X	L	X	H	H	PREVIOUSLY LOADED DISPLAY									G	R	E	Y
H	H	X	L	X	X	H	X	X	X	X	X	X	X	X	X	G	R	E	Y
H	X	H	L	X	X	H	X	X	X	X	X	X	X	X	X	G	R	E	Y
H	L	L	L	H	L	H	L	L	H	L	L	L	H	L	H	G	R	E	E
H	L	L	L	H	L	H	L	H	H	L	H	L	H	L	H	G	R	U	E
H	L	L	L	H	L	H	H	L	H	L	L	H	H	L	L	G	L	U	E
H	L	L	L	H	L	H	H	H	H	L	L	L	L	H	L	B	L	U	E
L	X	X	X	X	H	H	X	X	BLANK DISPLAY							G L U E			
H	L	L	L	H	L	H	H	H	H	L	L	L	H	H	H	G L U E			
H	X	X	L	X	H	L	X	X	CLEARS CHARACTER DISPLAYS							SEE CHARACTER SET			
H	L	L	L	H	L	H	X	X	SEE CHARACTER CODE							SEE CHARACTER SET			

X = DON'T CARE

LOADING CURSOR STATE TABLE

CONTROL							ADDRESS		DATA							DISPLAY DIGIT			
\overline{BL}	$\overline{CE1}$	$\overline{CE2}$	CUE	\overline{CU}	\overline{WR}	\overline{CLR}	A1	A0	D6	D5	D4	D3	D2	D1	D0	3	2	1	0
H	X	X	L	X	H	H	PREVIOUSLY LOADED DISPLAY									B	E	A	R
H	X	X	H	X	H	H	DISPLAY PREVIOUSLY STORED CURSORS									B	E	A	R
H	L	L	H	L	L	H	L	L	X	X	X	X	X	X	H	B	E	A	☒
H	L	L	H	L	L	H	L	H	X	X	X	X	X	X	H	B	E	☒	☒
H	L	L	H	L	L	H	H	L	X	X	X	X	X	X	H	B	☒	☒	☒
H	L	L	H	L	L	H	H	H	X	X	X	X	X	X	H	☒	☒	☒	☒
H	L	L	H	L	L	H	H	L	X	X	X	X	X	X	L	☒	E	☒	☒
H	X	X	L	X	H	H	DISABLE CURSOR DISPLAY									B	E	A	R
H	L	L	L	L	L	H	H	H	X	X	X	X	X	X	L	B	E	A	R
H	X	X	H	X	H	H	DISPLAY STORED CURSOR									B	E	☒	☒

X = DON'T CARE

QUALITY ASSURANCE LEVELS

The **MDL 2416TXVBs** are tested in conformance with Quality Level A of MIL-D-87157 for hermetically sealed LED displays with 100% screening: The product is tested to Tables I, II, IIIa and IVa.

The **MDL 2416TXVs** are tested in conformance with Quality Level A, Table I and Group A, Table II.

The **MDL 2416Cs** are tested in conformance with Quality Table I & II, Group A, except delta determinants in Table I.

Table I. Quality Level A of MIL-D-87157

Test Screen	Method	Conditions
1. Precap Visual	2072 MIL-STD-750	
2. High Temperature Storage	1032 MIL-STD-750	T _{amb} = 125°C, Time = 24 hours
3. Temperature Cycling	1051 MIL-STD-750	Condition B, 10 Cycles, 15 min. Dwell T _{amb} = -65°C to +125°C
4. Constant Acceleration	2006 MIL-STD-750	5,000 G's at Y ₁ Orientation
5. Fine Leak	1071 MIL-STD-750	Condition H, Leak Rate ≤ 5 × 10 ⁻⁷ cc/s
6. Gross Leak	1071 MIL-STD-750	Condition C
7. Interim Electrical/Optical Tests ⁽²⁾		I _{CC} , I _V at V _{CC} = 5.0 V, T _{amb} = 25°C.
8. Burn-In ⁽¹⁾	1015 MIL-STD-883	Condition B at V _{CC} = 5.5 V, T _{amb} = 100°C, t = 160 hours
9. Final Electrical Test ⁽²⁾		Same as Step 7.
10. Delta Determinants		ΔI _V = -20%, ΔI _{CC} = ± 10%, T _{amb} = 25°C
11. External Visual	2009 MIL-STD-883	

Notes:

- 1 MIL-STD-883 test method applies
- 2. Limits and conditions are per the Electrical/Optical Characteristics. The I_{OH} and I_{OL} tests are the inverse of V_{OH} and V_{OL} specified in the Electrical Characteristics.

Table II. Group A Electrical Tests - MIL-D-87157

Subgroup/Test	Parameters	LTPD
Subgroup 1 DC Electrical Tests at 25°C ⁽¹⁾	$I_{CC}(\$)$, $I_{CC}(\overline{CU})$, $I_{CC}(\overline{BL})$, I_{IL} , I_V and Visual Function at $V_{CC} = 5.0$ V.	5
Subgroup 2 Selected DC Electrical Tests at High Temperatures ⁽¹⁾	Same as Subgroup 1, except delete I_V Visual Function, $T_{amb} = 100^\circ\text{C}$	7
Subgroup 3 Selected DC Electrical Tests at Low Temperatures ⁽¹⁾	Same as Subgroup 1, except delete I_V Visual Function, $T_{amb} = -55^\circ\text{C}$	7
Subgroup 4, 5 and 6 Not Applicable		
Subgroup 7 Optical and Functional Tests at 25°C	Satisfied by Subgroup 1	5
Subgroup 8 External Visual	MIL-STD-883, Method 2009	7

Note:

1 Limits and conditions are per the Electrical/Optical Characteristics. The I_{OH} and I_{OL} tests are the inverse of V_{OH} and V_{OL} specified in the Electrical Characteristics

Table IIIa. Group B, Class A and B of MIL-D-87157

Subgroup/Test	MIL-STD-750 Method	Conditions	Sample Size
Subgroup 1 Resistance to Solvents	1022		4 Devices/0 Failures
Internal Visual and Mechanical ⁽³⁾	2014		1 Device/0 Failures
Subgroup 2 ^(1, 2) Solderability	2026	$T_{amb} = 245^\circ\text{C}$ for 5 seconds	LTPD = 15
Subgroup 3 Thermal Shock (Temp Cycle)	1051	Condition B, 10 Cycles, 15 min Dwell	LTPD = 15
Moisture Resistance	1021		
Fine Leak	1071	Condition H	
Gross Leak	1071	Condition C	
Electrical/Optical Endpoints ⁽⁴⁾		$I_{CC}(\$)$, $I_{CC}(\overline{CU})$, $I_{CC}(\overline{BL})$, I_{IL} , I_V and Visual Function at $T_{amb} = 25^\circ\text{C}$	
Subgroup 4 Operating Life Test (340 Hours)	1027	$T_{amb} = +100^\circ\text{C}$ at $V_{CC} = 5.5$ V	LTPD = 10
Electrical/Optical Endpoints ⁽⁴⁾	1010	Same as Subgroup 3	
Subgroup 5 Non-Operating (Storage) Life Test (340 hours)	1032	$T_{amb} = +125^\circ\text{C}$	LTPD = 10
Electrical/Optical Endpoints ⁽⁴⁾		Same as Subgroup 3	

Notes:

- 1 Whenever electrical/optical tests are not required as endpoints, electrical rejects may be used
- 2 The LTPD applies to the number of leads inspected except in no case shall less than 3 displays be used to provide the number of leads required

3 MIL-STD-883 test methods apply

4 Limits and conditions are per the Electrical/Optical Characteristics

5 Visual requirements shall be as specified in MIL STD-883, Methods 1011 or 1011

Intelligent Display Devices

Table IVa. Group C, Class A and B of MIL-D-87157

Subgroup/Test	MIL-STD-750 Method	Conditions	Sample Size
Subgroup 1 Physical Dimensions	2066		2 Devices/0 Failures
Subgroup 2 ^(2, 6) Lead Integrity	2004	Condition B2	LTPD = 15
Fine Leak	1071	Condition H	
Gross Leak	1071	Condition C	
Subgroup 3 Shock	2016	1500G, Time = 0.5 ms, 5 Blows in Each Orientation X1, Y1, Z1	LTPD = 15
Vibration, Variable Frequency	2056		
Constant Acceleration	2006	5,000 at Y1 Orientation	
External Visual ⁽⁴⁾	1010 or 1011		
Electrical/Optical Endpoints ⁽⁷⁾		$I_{CC}(\$)$, $I_{CC}(\overline{CU})$, $I_{CC}(\overline{BL})$, I_{IL} , I_V at $V_{CC} = 5.0$ V and Visual Function $T_{amb} = 25^\circ\text{C}$.	
Subgroup 4 ^(1, 3) Salt Atmosphere	1041		LTPD = 15
External Visual ⁽⁴⁾	1010 or 1011		
Subgroup 5 Bond Strength ⁽⁵⁾	2037	Condition A	LTPD = 20 (C = 0)
Subgroup 6 Operating Life Test ⁽⁸⁾	1026	$T_{amb} = +100^\circ\text{C}$ at $V_{CC} = 5.50$ V	$\lambda = 10$
Electrical/Optical Endpoints ⁽⁸⁾		Same as Subgroup 3	

Notes:

- 1 Whenever electrical/optical tests are not required as endpoints, electrical rejects may be used
- 2 The LTPD applies to the number of leads inspected except in no case shall less than three displays be used to provide the number of leads required
- 3 Solderability samples shall not be used
- 4 Visual requirements shall be as specified in MIL-STD-883, Methods 1010 or 1011
- 5 Displays may be selected prior to seal.

- 6 MIL-STD-883 test method applies
- 7 Limits and conditions are per the electrical/optical characteristics
- 8 Test method or conditions in accordance with detail specification. If a lot undergoing Group B inspection has been selected to satisfy Group C inspection requirements, the 340 hour life tests may be continued on test to 1,000 hours to satisfy the Group C life test requirements. In such cases the 340 hour endpoint measurements shall be made on a basis for Group B lot acceptance or the 1,000 hour endpoint shall be used as the basis for both Group B and Group C acceptance