

TOSHIBA

MG400J2YS50

TOSHIBA GTR MODULE SILICON N CHANNEL IGBT

MG400J2YS50

HIGH POWER SWITCHING APPLICATIONS.
MOTOR CONTROL APPLICATIONS.

Unit in mm

- The Electrodes are Isolated from Case.
- High Input Impedance
- Includes a Complete Half Bridge in One Package.
- Enhancement-Mode
- High Speed : $t_f=0.30\mu s$ (Max.) ($I_C=400A$)
 $t_{rr}=0.15\mu s$ (Max.) ($I_F=400A$)
- Low Saturation Voltage
: $V_{CE(sat)}=2.70V$ (Max.) ($I_C=400A$)

EQUIVALENT CIRCUIT

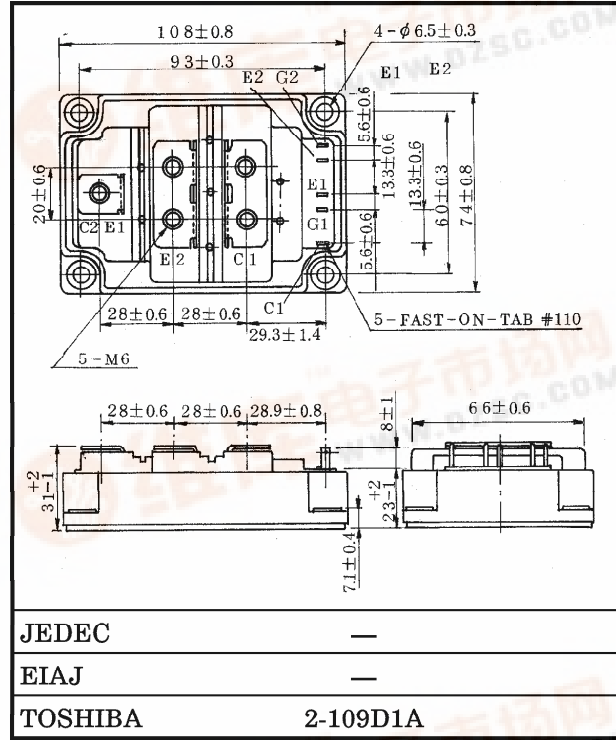
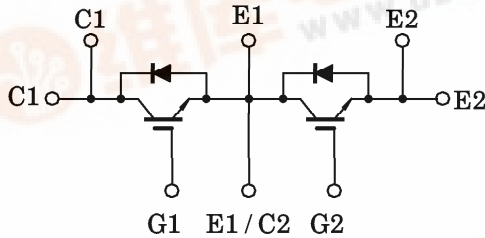

Weight : 540g (TYP.)

MAXIMUM RATINGS ($T_a = 25^\circ C$)

CHARACTERISTIC	SYMBOL	RATING	UNIT
Collector-Emitter Voltage	V_{CES}	600	V
Gate-Emitter Voltage	V_{GES}	± 20	V
Collector Current	DC	I_C	400
	1ms	I_{CP}	800
Forward Current	DC	I_F	400
	1ms	I_{FM}	800
Collector Power Dissipation ($T_c = 25^\circ C$)	P_C	1800	W
Junction Temperature	T_j	150	$^\circ C$
Storage Temperature Range	T_{stg}	-40~125	$^\circ C$
Isolation Voltage	V_{Isol}	2500 (AC 1minute)	V
Screw Torque (Terminal / Mounting)	—	3 / 3	N·m

961001EAA2

TOSHIBA is continually working to improve the quality and the reliability of its products. Nevertheless, semiconductor devices in general can malfunction or fail due to their inherent electrical sensitivity and vulnerability to physical stress. It is the responsibility of the buyer, when utilizing TOSHIBA products, to observe standards of safety, and to avoid situations in which a malfunction or failure of a TOSHIBA product could cause loss of human life, bodily injury or damage to property. In developing your designs, please ensure that TOSHIBA products are used within specified operating ranges as set forth in the most recent products specifications. Also, please keep in mind the precautions and conditions set forth in the TOSHIBA Semiconductor Reliability Handbook.

ELECTRICAL CHARACTERISTICS (Ta = 25°C)

CHARACTERISTIC		SYMBOL	TEST CONDITION	MIN.	TYP.	MAX.	UNIT
Gate Leakage Current		I_{GES}	$V_{GE} = \pm 20V, V_{CE} = 0$	—	—	± 500	nA
Collector Cut-off Current		I_{CES}	$V_{CE} = 600V, V_{GE} = 0$	—	—	3.0	mA
Gate-Emmitter Cut-off Voltage		$V_{GE(off)}$	$I_C = 40mA, V_{CE} = 5V$	5.0	7.0	8.0	V
Collector-Emmitter Saturation Voltage		$V_{CE(sat)}$	$I_C = 400A, V_{GE} = 15V$	—	2.10	2.70	V
Input Capacitance		C_{ies}	$V_{CE} = 10V, V_{GE} = 0$ $f = 1MHz$	—	46500	—	pF
Switching Time	Turn-on Delay Time	$t_{d(on)}$	Inductive Load $V_{CC} = 300V$ $I_C = 400A$ $V_{GE} = \pm 15V$ $R_G = 2.4\Omega$ (Note 1)	—	0.25	0.50	μs
	Rise Time	t_r		—	0.12	0.24	
	Turn-on Time	t_{on}		—	0.40	0.80	
	Turn-off Delay Time	$t_{d(off)}$		—	0.30	0.60	
	Fall Time	t_f		—	0.15	0.30	
	Turn-off Time	t_{off}		—	0.50	1.00	
Forward Voltage		V_F	$I_F = 400A, V_{GE} = 0$	—	2.30	3.00	V
Reverse Recovery Time		t_{rr}	$I_F = 400A, V_{GE} = -10V$ $di/dt = 400A/\mu s$	—	0.08	0.15	μs
Thermal Resistance		$R_{th(j-c)}$	Transistor Stage	—	—	0.069	$^{\circ}C/W$
			Diode stage	—	—	0.17	
		$R_{th(c-f)}$	Case to Fin (Note 2)	—	—	0.10	

Note 1 Switching Time Test Circuit & Timing Chart

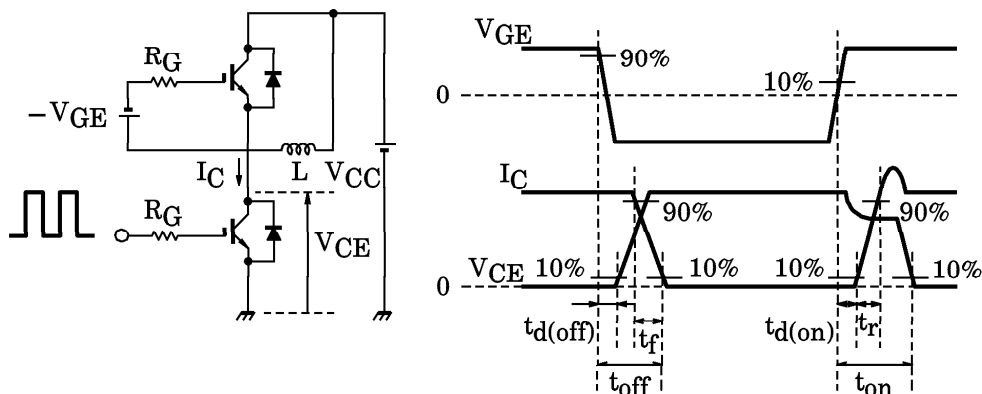

Note 2 Silicone Grease is applied.

