

MGF0905A

L, S BAND POWER GaAs FET

DESCRIPTION

The MGF0905A, GaAs FET with an N-channel schottky gate, is designed for use in UHF band amplifiers.

FEATURES

- High output power
 $P_O = 34\text{dBm (TYP.) @ } f = 1.65\text{GHz, } P_{in} = 26\text{dBm}$
- High power gain
 $G_P = 8\text{dB (TYP.) @ } f = 1.65\text{GHz, } P_{in} = 26\text{dBm}$
- High power added efficiency
 $\eta_{add} = 40\% \text{ (TYP.) @ } f = 1.65\text{GHz, } P_{in} = 26\text{dBm}$

APPLICATION

For UHF Band power amplifiers

QUALITY GRADE

- GG

RECOMMENDED BIAS CONDITIONS

- $V_{DS} = 8\text{V}$
- $I_D = 800\text{mA}$
- $R_g = 100\Omega$
- Refer to Bias Procedure

ABSOLUTE MAXIMUM RATINGS ($T_a = 25^\circ\text{C}$)

Symbol	Parameter	Ratings	Unit
V_{GS0}	Gate to source voltage	-17	V
V_{GD0}	Gate to drain voltage	-17	V
I_D	Drain current	3200	mA
I_{GR}	Reverse gate current	-10	mA
I_{GF}	Forward gate current	21.5	mA
P_T	Total power dissipation * 1	12	W
T_{ch}	Channel temperature	175	$^\circ\text{C}$
T_{stg}	Storage temperature	-65 ~ +175	$^\circ\text{C}$

* 1: $T_c = 25^\circ\text{C}$

ELECTRICAL CHARACTERISTICS ($T_a = 25^\circ\text{C}$)

Symbol	Parameter	Test conditions	Limits			Unit
			Min	Typ	Max	
I_{DSS}	Saturated drain current	$V_{DS} = 3\text{V, } V_{GS} = 0\text{V}$	1600	2400	3200	mA
$V_{GS}(\text{off})$	Gate to source cut-off voltage	$V_{DS} = 3\text{V, } I_D = 10\text{mA}$	-1	-3	-5	V
g_m	Transconductance	$V_{DS} = 3\text{V, } I_D = 800\text{mA}$	500	800	—	mS
P_O	Output power	$V_{DS} = 8\text{V, } I_D = 800\text{mA, } f = 1.65\text{GHz, } P_{in} = 26\text{dBm}$	33	34	—	dBm
η_{add}	Power added efficiency		—	40	—	%
$R_{th}(\text{ch-c})$	Thermal resistance * 1	ΔV_f method	—	—	12.5	$^\circ\text{C/W}$
$R_{th}(\text{ch-a})$	Thermal resistance * 2	ΔV_f method	—	—	72.5	$^\circ\text{C/W}$

* 1: Channel to case * 2: Channel to ambient

OUTLINE DRAWING

Unit: millimeters (inches)

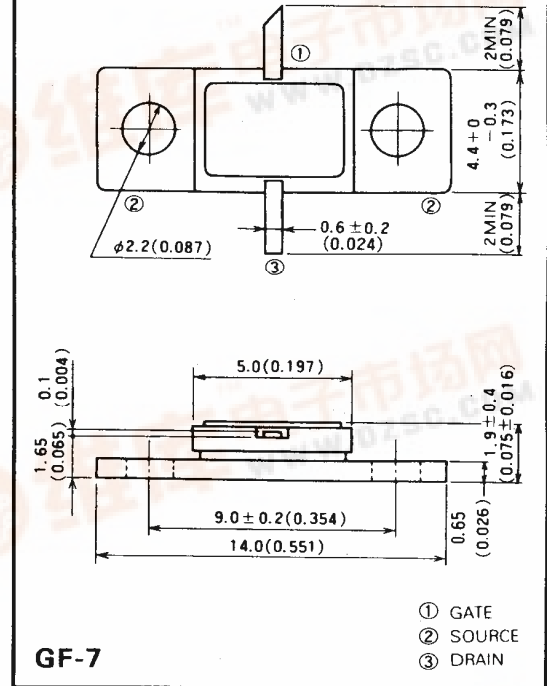

L, S BAND POWER GaAs FET

TYPICAL CHARACTERISTICS

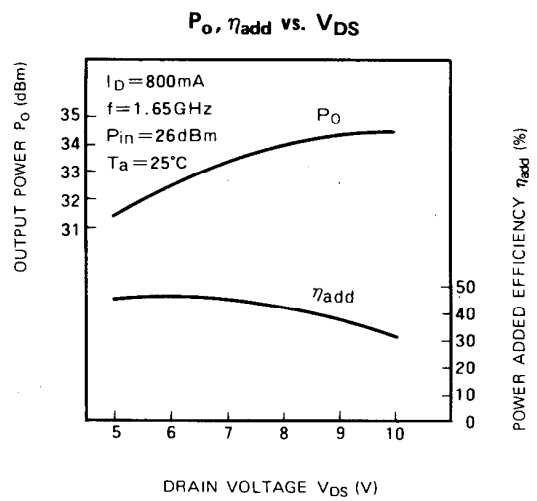
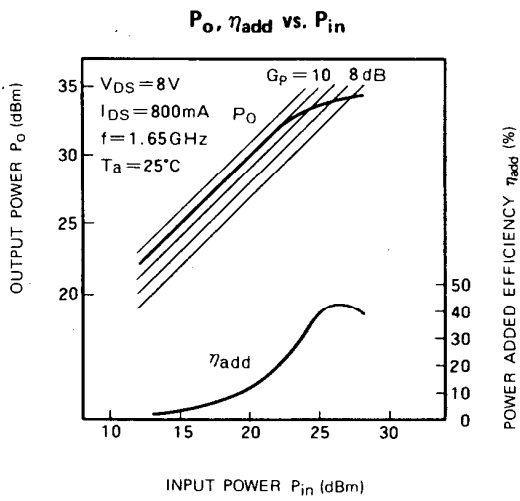
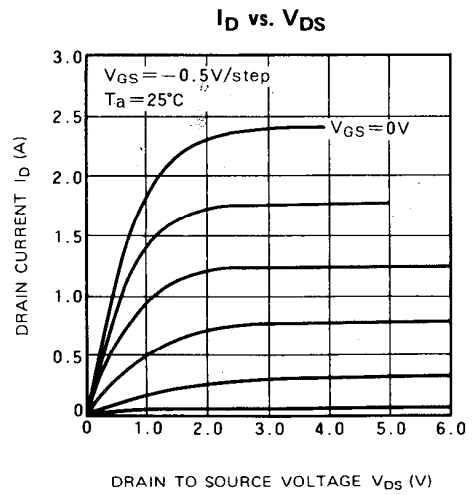
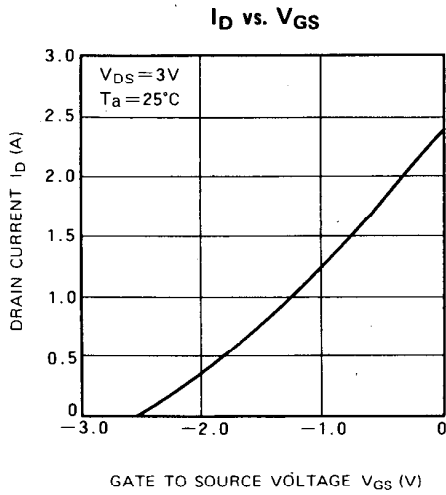

MGF0905A

L, S BAND POWER GaAs FET

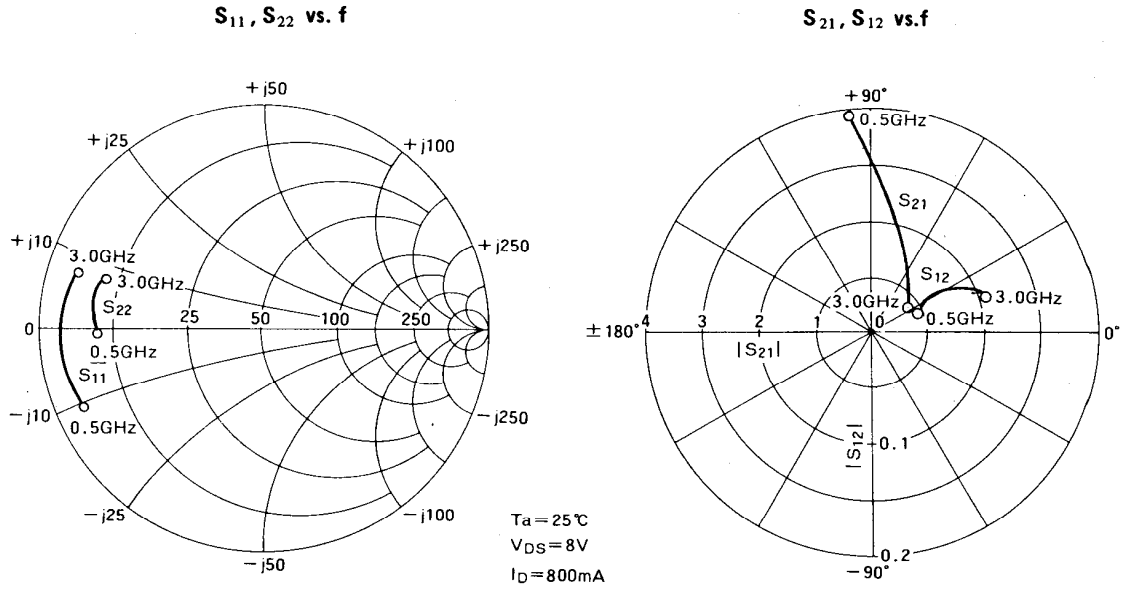

S PARAMETERS ($T_a = 25^\circ\text{C}$, $V_{DS} = 8\text{V}$, $I_D = 800\text{mA}$)

f (GHz)	S_{11}		S_{21}		S_{12}		S_{22}		K	MSG/MAG dB
	Magn.	Angle (deg.)	Magn.	Angle (deg.)	Magn.	Angle (deg.)	Magn.	Angle (deg.)		
0.5	0.861	-155.5	3.895	96.0	0.022	25.0	0.731	-179.0	0.806	22.5
1.0	0.887	-170.5	1.999	78.0	0.025	33.0	0.753	175.5	1.133	16.8
1.5	0.894	177.0	1.485	68.0	0.033	33.0	0.747	172.5	1.175	14.0
2.0	0.887	173.0	1.205	58.0	0.039	29.0	0.743	169.5	1.205	12.2
2.5	0.877	169.0	1.000	48.5	0.047	24.0	0.738	166.5	1.221	10.4
3.0	0.864	165.0	0.795	35.0	0.054	18.0	0.723	164.0	1.365	8.1