

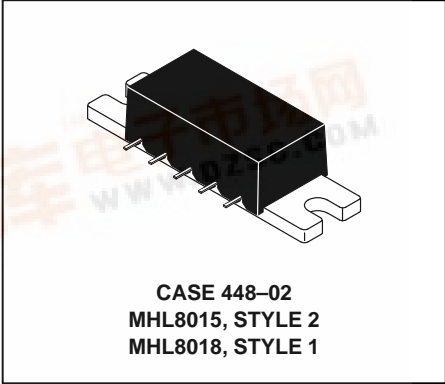
The RF Line UHF Linear Amplifier

Designed for linear amplifier applications in 50 ohm systems requiring wide bandwidth, low noise, and low distortion. Internal DC blocking on RF ports reduces external component count and related circuit area. This hybrid utilizes push-pull circuit design.

- Supply Voltage: 15 Vdc (MHL8015)
 28 Vdc (MHL8018)
- Third Order Intercept: 38 dBm Typ
- Power Gain: 18.5 dB Typ (@ f = 900 MHz)
- Excellent Phase Linearity and Group Delay Characteristics
- 50 Ohm Input/Output Impedances

MHL8015
MHL8018

400 mW, 18.5 dB
40–1000 MHz
LINEAR AMPLIFIERS



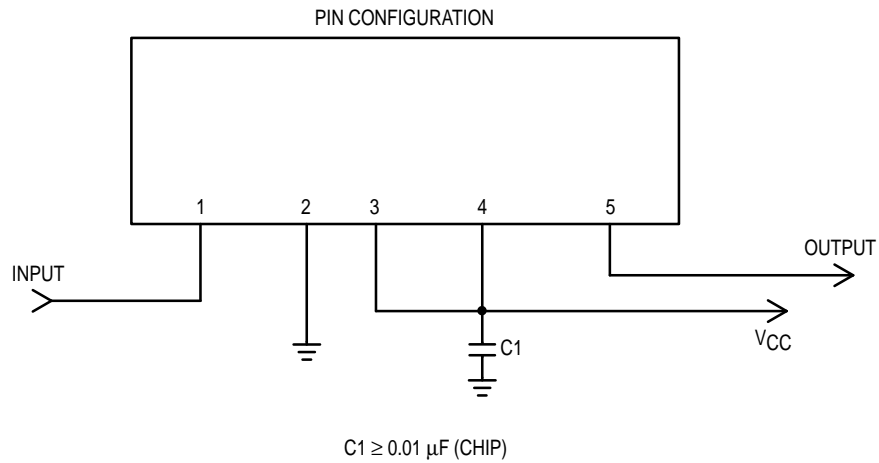
ABSOLUTE MAXIMUM RATINGS (T_C = 25°C unless otherwise noted)

Rating	Symbol	Value	Unit
DC Supply Voltage	V _{CC}	18 32	Vdc
RF Input Power	P _{in}	+14	dBm
Storage Temperature Range	T _{stg}	-40 to +100	°C
Operating Case Temperature Range	T _C	-20 to +100	°C

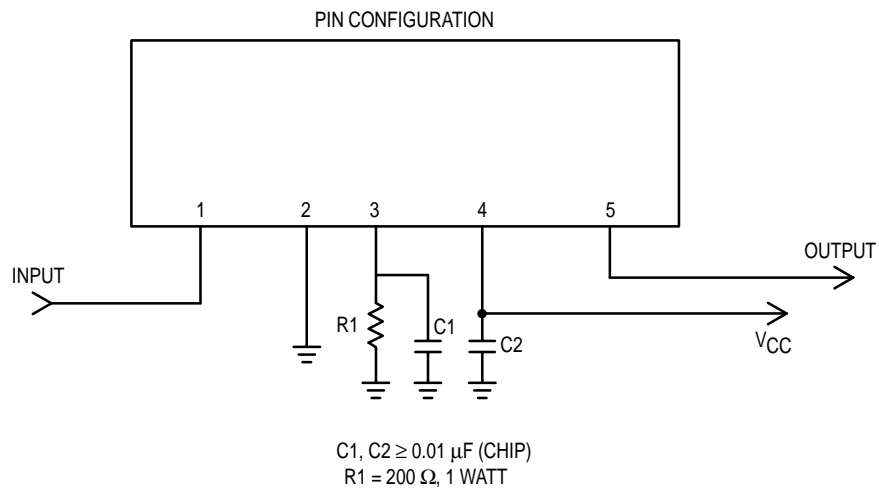
ELECTRICAL CHARACTERISTICS (T_C = +25°C; V_{CC} = 15 Vdc (MHL8015), 28 Vdc (MHL8018); 50 Ω System)

Characteristic	Symbol	Min	Typ	Max	Unit
Supply Current	I _{DC}	—	380 210	410 240	mA
Power Gain	P _G	17.5	18.5	19.5	dB
Gain Flatness	FL	—	1.0	2.0	dB
Power Output @ 1 dB Comp.	P _{out 1 dB}	25	26	—	dBm
Third Order Intercept (f ₁ = 879 MHz, f ₂ = 884 MHz)	ITO	37	38	—	dBm
Input/Output VSWR	VSWR	—	—	2.0:1 2.6:1	
Noise Figure, Broadband	NF	—	6.5 7.5	8.0 9.0	dB
Second Harmonic Distortion (P _O = 100 mW, f _{2H} = 1000 MHz)	d _{so}	—	-50	-40	dB
Second Order Intermodulation Distortion (P _O = 2.75 dBm, f ₁ = 373 MHz, f ₂ = 450 MHz)	IM2	—	—	-60	dB
Intermodulation Distortion, 3 Tone (f = 860 MHz, P _{sync} = 200 mW)	IM3	—	-60	—	dB



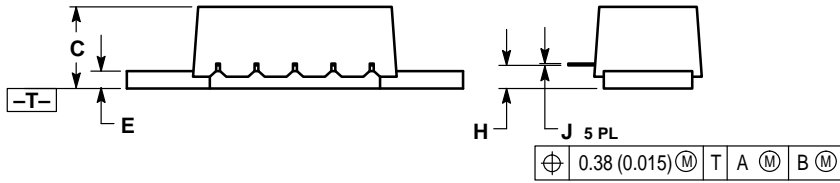
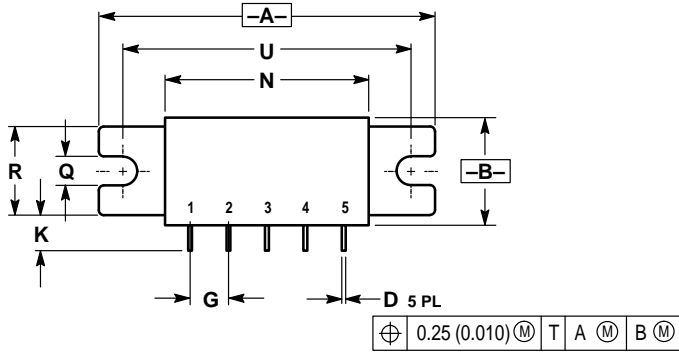


**Figure 1. MHL8015 External Connections
(Case 448-02, Style 2)**



**Figure 2. MHL8018 External Connections
(Case 448-02, Style 1)**

PACKAGE DIMENSIONS




- NOTES:
 1. DIMENSIONING AND TOLERANCING PER ANSI Y14.5M, 1982.
 2. CONTROLLING DIMENSION: INCH.

DIM	INCHES		MILLIMETERS	
	MIN	MAX	MIN	MAX
A	1.740	1.760	44.20	44.70
B	0.550	0.570	13.97	14.49
C	0.405	0.445	10.29	11.30
D	0.018	0.022	0.46	0.55
E	0.085	0.095	2.16	2.41
G	0.200 BSC		5.08 BSC	
H	0.120 BSC		3.05 BSC	
J	0.009	0.011	0.23	0.28
K	0.180	0.220	4.57	5.59
N	1.045	1.075	26.54	27.30
Q	0.145	0.155	3.68	3.94
R	0.455	0.465	11.56	11.81
U	1.490	1.510	37.85	38.35

- STYLE 1:
 PIN 1. RF INPUT
 2. GROUND
 3. RESISTOR-GROUND
 4. VCC
 5. RF OUTPUT
- STYLE 2:
 PIN 1. RF INPUT
 2. GROUND
 3. VCC1
 4. VCC2
 5. RF OUTPUT

CASE 448-02
 ISSUE A

Motorola reserves the right to make changes without further notice to any products herein. Motorola makes no warranty, representation or guarantee regarding the suitability of its products for any particular purpose, nor does Motorola assume any liability arising out of the application or use of any product or circuit, and specifically disclaims any and all liability, including without limitation consequential or incidental damages. "Typical" parameters which may be provided in Motorola data sheets and/or specifications can and do vary in different applications and actual performance may vary over time. All operating parameters, including "Typicals" must be validated for each customer application by customer's technical experts. Motorola does not convey any license under its patent rights nor the rights of others. Motorola products are not designed, intended, or authorized for use as components in systems intended for surgical implant into the body, or other applications intended to support or sustain life, or for any other application in which the failure of the Motorola product could create a situation where personal injury or death may occur. Should Buyer purchase or use Motorola products for any such unintended or unauthorized application, Buyer shall indemnify and hold Motorola and its officers, employees, subsidiaries, affiliates, and distributors harmless against all claims, costs, damages, and expenses, and reasonable attorney fees arising out of, directly or indirectly, any claim of personal injury or death associated with such unintended or unauthorized use, even if such claim alleges that Motorola was negligent regarding the design or manufacture of the part. Motorola and  are registered trademarks of Motorola, Inc. Motorola, Inc. is an Equal Opportunity/Affirmative Action Employer.

Mfax is a trademark of Motorola, Inc.

How to reach us:

USA/EUROPE/Locations Not Listed: Motorola Literature Distribution;
P.O. Box 5405, Denver, Colorado 80217. 303-675-2140 or 1-800-441-2447

JAPAN: Nippon Motorola Ltd.: SPD, Strategic Planning Office, 4-32-1,
Nishi-Gotanda, Shinagawa-ku, Tokyo 141, Japan. 81-3-5487-8488

Mfax™: RMFOX0@email.sps.mot.com – TOUCHTONE 602-244-6609
– US & Canada ONLY 1-800-774-1848

ASIA/PACIFIC: Motorola Semiconductors H.K. Ltd.; 8B Tai Ping Industrial Park,
51 Ting Kok Road, Tai Po, N.T., Hong Kong. 852-26629298

INTERNET: <http://motorola.com/sps>



MOTOROLA