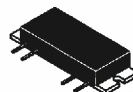

MOTOROLA
SEMICONDUCTOR
TECHNICAL DATA**MHW812A3****The RF Line**
UHF Power Amplifier

... designed for 13 Volt UHF power amplifier applications in industrial and commercial FM equipment operating from 890 to 915 MHz.

- Specified 13 Volt, UHF Characteristics
Output Power = 12 Watts
Minimum Gain = 20.8 dB
Harmonics = -42 dBc Max ($2f_0$)
 -60 dBc Max ($3f_0$ and Higher)
- 50 Ω Input/Output Impedances
- Guaranteed Stability and Ruggedness
- Features Three Common-Emitter Gain Stages
- Epoxy Glass PCB Construction Gives Consistent Performance and Reliability
- Gold-Metallized and Silicon Nitride-Passivated Transistor Chips
- Controllable, Stable Performance Over More Than 35 dB Range in Output Power

12 W, 890–915 MHz
HIGH GAIN RF POWER
AMPLIFIERS

CASE 301H, STYLE 2

MAXIMUM RATINGS

Rating	Symbol	Value	Unit
DC Supply Voltages	V_{S1}	16	Vdc
RF Input Power	P_{In}	200	mW
RF Output Power	P_{Out}	15	W
Storage Temperature Range	T_{stg}	-30 to +100	$^{\circ}\text{C}$
Operating Case Temperature Range	T_C	-30 to +100	$^{\circ}\text{C}$
DC Control Voltage	V_{Cont}	12.5	Vdc

ELECTRICAL CHARACTERISTICS (Flange Temperature = 25 $^{\circ}\text{C}$, 50 Ω system, and V_{S1} = 13 V unless otherwise noted)

Characteristic	Symbol	Min	Typ	Max	Unit
Frequency Range	BW	890	—	915	MHz
Power Gain (V_{Cont} = 12.5 Vdc, P_{Out} = 12 W)	G_p	20.8	21.5	—	dB
Efficiency (1) (P_{Out} = 12 W)	η	40	45	—	%
Harmonic Output (1) (P_{Out} = 12 W Reference)	$2f_0$ $3f_0$ and Higher	—	—	-42 -60	dBc
Input VSWR (1) (P_{Out} = 12 W, 50 Ω Reference, Reflected Signal Filtered to Eliminate Harmonic Content)	$VSWR_{in}$	—	—	2:1	—

NOTE:
1. P_{In} = 100 mW; adjust V_{Cont} for specified P_{Out} .

(continued)

ELECTRICAL CHARACTERISTICS — continued(Flange Temperature = 25°C, 50 Ω system, and $V_{S1} = 13$ V unless otherwise noted)

Characteristic	Symbol	Min	Typ	Max	Unit	
Power Degradation (-30 to +80°C) (1) (Reference $P_{out} = 12$ W @ $T_C = 25$ °C)	—	—	—	1.7	dB	
Load Mismatch Stress (1) ($V_{S1} = 16$ Vdc, $P_{out} = 13$ W, VSWR = 30:1, all phase angles)	ψ	No degradation in Power Output				
Stability ($P_{in} = 0$ to 200 mW, $V_{S1} = 10$ to 16 Vdc, $V_{Cont} = 0$ to 12.5 Vdc, Load VSWR = 4:1, P_{out} Max = 13 W) (2)		All spurious outputs ≥ 70 dB below desired output signal level				
Quiescent Current @ $V_{Cont} = 12.5$ V (I_{Cont} with no RF drive applied)	I_{Cont}	—	—	225	mA	
Control Voltage	$P_{in} = 100$ mW $P_{out} = 12$ W $V_{Cont} = 12.5$ V	V_{Cont}	0	9	12.5	Vdc
Control Current		I_{Cont}	0	155	225	mA

NOTES:

- $P_{in} = 100$ mW; adjust V_{Cont} for specified P_{out} .
- Combination of P_{in} , V_{S1} and V_{Cont} can not exceed max $P_{out} = 15$ W.

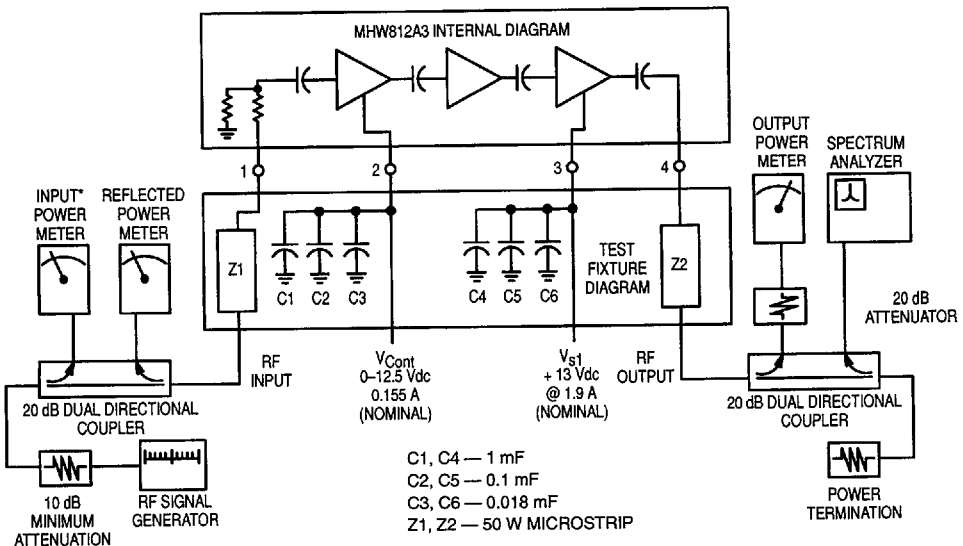

*Module input power is forward power as sampled by the directional coupler and read on the input power meter.

Figure 1. UHF Power Amplifier Test System Diagram

TYPICAL CHARACTERISTICS

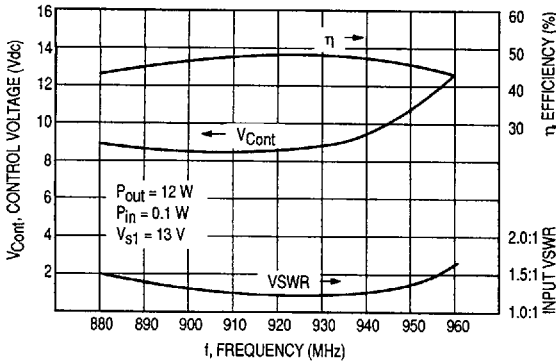

Figure 2. Control Voltage, Efficiency and VSWR versus Frequency

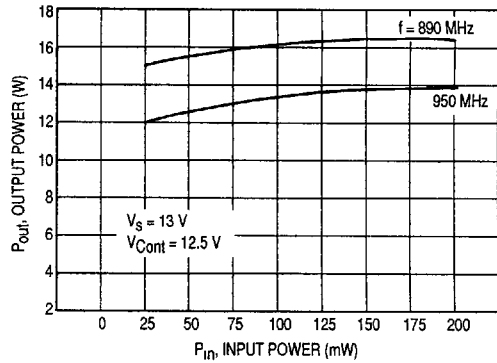

Figure 3. Output Power versus Input Power

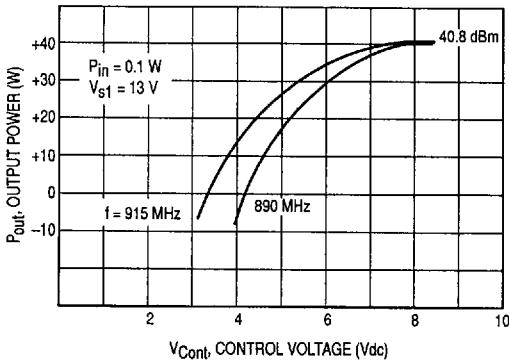

Figure 4. Output Power versus Control Voltage

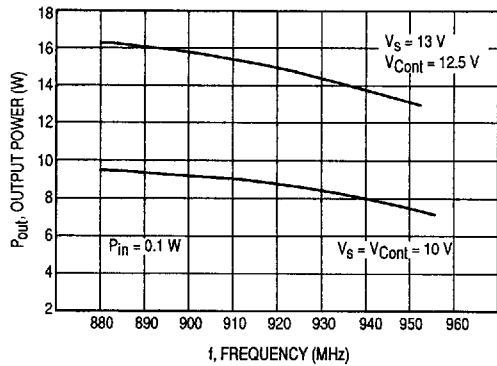

Figure 5. Output Power versus Frequency

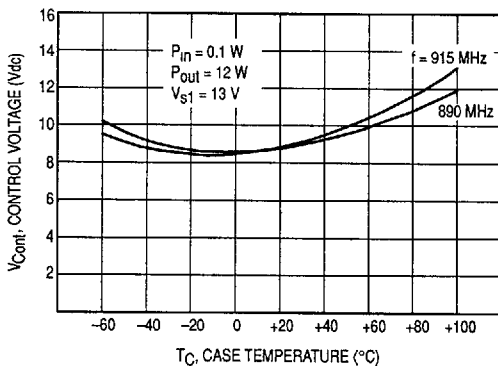

Figure 6. Control Voltage versus Case Temperature

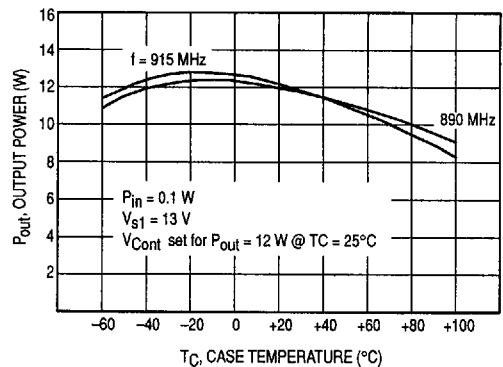

Figure 7. Output Power versus Case Temperature

APPLICATIONS INFORMATION

Nominal Operation

All electrical specifications are based on the following nominal conditions: ($P_{out} = 12\text{ W}$, $V_{S1} = 13\text{ Vdc}$). This module is designed to have excess gain margin with ruggedness, but operation outside the limits of the published specifications is not recommended unless prior communications regarding the intended use have been made with a factory representative.

Gain Control

In general, the module output power should be limited to 13 watts. The preferred method of power output control is to fix V_{S1} at 13 volts, set RF drive level and vary the control voltage from 0 to 12.5 Volts. As designed, the module exhibits a gain control range greater than 35 dB using the method described above.

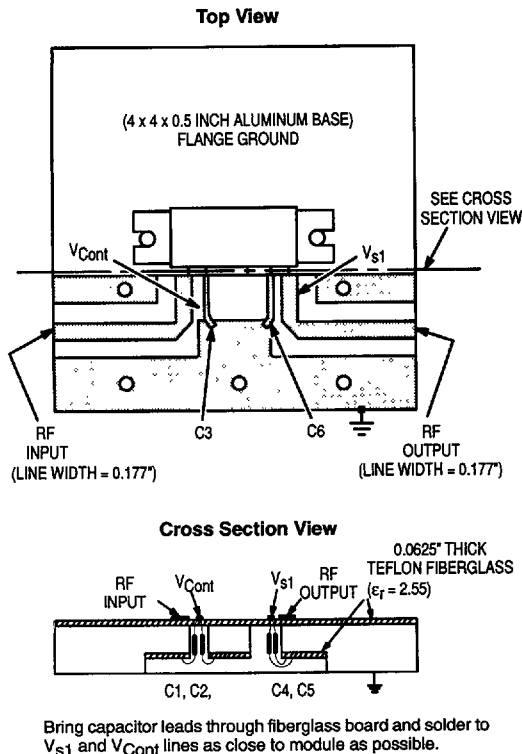

Figure 9. Test Fixture Construction

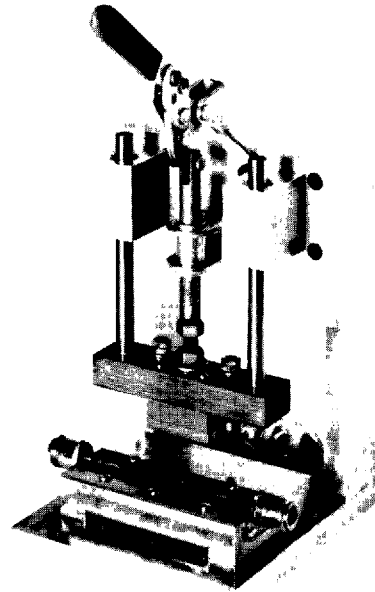

Figure 8. Test Fixture Assembly

Decoupling

Due to the high gain of each of the three stages and the module size limitation, external decoupling networks require careful consideration. Both Pins 2 and 3 are internally bypassed with a $0.018\ \mu\text{F}$ chip capacitor which is effective for frequencies from 5 MHz through 960 MHz. For bypassing frequencies below 5 MHz, networks equivalent to that shown in the test fixture schematic are recommended. Inadequate decoupling will result in spurious outputs at specific operating frequencies and phase angles of input and output VSWR.

Load Mismatch Stress

During final test, each module is load mismatch stress tested in a fixture having the identical decoupling network described in Figure 1. Electrical conditions are V_{S1} equal to 16 volts, load VSWR 30:1 and output power equal to 13 watts.

Mounting Considerations

To insure optimum heat transfer from the flange to heat-sink, use standard 6-32 mounting screws and an adequate quantity of silicone thermal compound (e.g., Dow Corning 340). With both mounting screws finger tight, alternately torque down the screws to 4-6 inch pounds. The heatsink mounting surface directly beneath the module flange should be flat to within 0.0015 inch. For more information on module mounting, see EB-107.