

The RF Line UHF Power Amplifiers

... designed specifically for the Pan European digital 2.0 watt, GSM hand-held radio. The MHW903, MHW953 and MHW954 are capable of wide power range control, operate from a 7.2 volt supply and require 1.0 mW (MHW903/953) or 100 mW (MHW954) of RF input power.

- Specified 7.2 Volt Characteristics:
 - RF Input Power — 1.0 mW (0 dBm) MHW903/953; 100 mW (20 dBm) MHW954
 - RF Output Power — 3.5 W
 - Minimum Gain — 35.4 dB (MHW903/953) or 15.4 dB (MHW954)
 - Harmonics — -35 dBc Max @ 2.0 f_o (MHW903/953) or -30 dBc Max @ 2.0 f_o (MHW954)
- New Biasing and Control Techniques Providing Dynamic Range and Control Circuit Bandwidth Ideal for GSM
- Low Control Current
- 50 Ohm Input/Output Impedances
- Guaranteed Stability and Ruggedness
- Test fixture circuit board photomaster available upon request by contacting RF Tactical Marketing in Phoenix, AZ.

MHW903
MHW953
MHW954

3.5 W
890 to 915 MHz
RF POWER
AMPLIFIERS

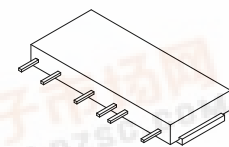

CASE 413A-02, STYLE 1
(MHW903)

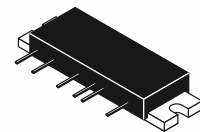

CASE 301V-02, STYLE 1
(MHW953)

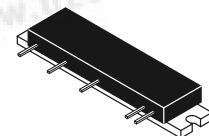

CASE 301Y-02, STYLE 1
(MHW954)

MAXIMUM RATINGS (Flange Temperature = 25°C)

Rating	Symbol	Value	Unit
DC Supply Voltage	V_{s1}, V_{s2}, V_{s3}	9.0	Vdc
DC Bias Voltage (MHW903/953) (MHW954)	V_b	5.25 4.75	Vdc
DC Control Voltage (MHW903/953 only)	V_{cont}	3.0	Vdc
RF Input Power (MHW903/953) (MHW954)	P_{in}	2.0 400	mW
RF Output Power ($V_s = 9.0$ Vdc)	P_{out}	4.5	W
Operating Case Temperature Range	T_C	-30 to +100	°C
Storage Temperature Range	T_{stg}		

ELECTRICAL CHARACTERISTICS ($V_{s1} = V_{s2} = V_{s3} = 7.2$ Vdc; $V_b = 5.0$ Vdc for MHW903/953)
 ($V_{s1} = V_{s2} = 7.2$ Vdc; $V_b = 4.5$ Vdc for MHW954)
 ($T_C = 25^\circ\text{C}$; 50 ohm system, unless otherwise noted)

Characteristic	Symbol	Min	Max	Unit
Frequency Range	BW	890	915	MHz
Power Gain ($P_{out} = 3.5$ mW) MHW903/953 (1) MHW954 (2)	G_p	35.4 15.4	—	dB
Control Current ($P_{out} = 3.5$ W; $P_{in} = 1.0$ mW) MHW903/953 only (1)	I_{cont}	—	1.0	mA
Supply Current ($P_{out} = 3.5$ W; $P_{in} = 1.0$ mW) MHW903/953 only (1)	I_b	—	85	mA
Leakage Current ($P_{in} = 0$ mW; $V_{cont} = V_b = 0$ Vdc; $V_{s1} = V_{s2} = V_{s3} = 9.0$ Vdc for MHW903/953. $P_{in} = 0$ mW; $V_b = 0$ Vdc; $V_{s1} = V_{s2} = 9.0$ Vdc for MHW954)	I_L	—	1.0 200	mA μA
Input VSWR ($P_{out} = 3.5$ W; $P_{in} = 1.0$ mW) MHW903/953 (1) ($P_{out} = 3.5$ W) MHW954 (2)	VSWR _{in}	—	2.0:1	—

NOTES:

- Adjust V_{cont} for specified P_{out} ; duty cycle = 12.5%, period = 4.6 ms
- Adjust P_{in} for specified P_{out} ; duty cycle = 12.5%, period = 4.6 ms

ELECTRICAL CHARACTERISTICS — continued ($V_{S1} = V_{S2} = V_{S3} = 7.2$ Vdc; $V_b = 5.0$ Vdc for MHW903/953)
 ($V_{S1} = V_{S2} = 7.2$ Vdc; $V_b = 4.5$ Vdc for MHW954)
 ($T_C = 25^\circ\text{C}$; 50 ohm system, unless otherwise noted)

Characteristic	Symbol	Min	Max	Unit
Efficiency ($P_{Out} = 3.5$ W; $P_{In} = 1.0$ mW) MHW903/953 (1) ($P_{Out} = 3.5$ W) MHW954 (2)	η	40	—	%
Harmonics ($P_{Out} = 3.5$ W; $P_{In} = 1.0$ mW) MHW903/953 (1) $2.0 f_o$ $3.0 f_o$ ($P_{Out} = 3.5$ W) MHW954 (2) $2.0 f_o$ $3.0 f_o$	—	—	-35 -45 -30 -40	dBc
Noise Power (In 30 kHz Bandwidth, 20 MHz above f_o) ($T_C = 25^\circ\text{C} - 100^\circ\text{C}$) ($P_{Out} = 0.3 - 3.5$ W; $V_{S1} = V_{S2} = V_{S3} = 6.25 - 9.0$ Vdc, $P_{In} = 1.0$ mW) MHW903/953 (1) ($P_{Out} = 0.3 - 3.5$ W; $V_{S1} = V_{S2} = 6.25 - 9.0$ Vdc) MHW954 (2)	—	—	-65 -75	dBm
Output Power, Low Voltage ($P_{In} = 1.0$ mW; $V_{S1} = V_{S2} = V_{S3} = 6.25$ Vdc; $V_{Cont} = 3.0$ Vdc) MHW903/953 ($P_{In} = 100$ mW; $V_{S1} = V_{S2} = 6.25$ Vdc) MHW954	P_{O1}	2.0 2.3	—	W
Isolation ($P_{In} = 1.0$ mW; $V_{Cont} = 0$ Vdc; $V_{S1} = V_b = 0 - 5$ Vdc) MHW903/953 only (1)	—	—	-36	dBm
3.0 dB V_{Cont} Bandwidth ($P_{In} = 1.0$ mW; $P_{Out} = 0.03 - 3.5$ W) MHW903/953 only (1)	—	1.0	—	MHz
% AM In Output ($P_{Out} = 0.035 - 3.5$ W; 135 kHz, 1% AM on Input) MHW954 only (2)	—	—	6	%
Load Mismatch Stress ($P_{In} = 2.0$ mW; $P_{Out} = 3.5$ W; $V_{S1} = V_{S2} = V_{S3} = 9.0$ Vdc) MHW903/953 (1) ($P_{Out} = 3.5$ W; $V_b = 4.75$ Vdc; $V_{S1} = V_{S2} = 9.0$ Vdc) MHW954 (2) (Load VSWR = 10:1, All Phase Angles at Frequency of Test)	ψ	No degradation in output power before and after test		
Stability ($P_{In} = 0.5$ to 2.0 mW; $P_{Out} = 0.03 - 3.5$ W; $V_{S1} = V_{S2} = V_{S3} = 6.0$ to 9.0 Vdc) MHW903/953 (1) ($P_{Out} = 0.03 - 3.5$ W; $V_{S1} = V_{S2} = 6.0$ to 9.0 Vdc) MHW954 (2) (Load VSWR = 6:1, Source VSWR = 3:1, All Phase Angles at Frequency of Test)	—	All spurious outputs more than 60 dB below desired signal		

NOTES:

1. Adjust V_{Cont} for specified P_{Out} ; duty cycle = 12.5%, period = 4.6 ms
2. Adjust P_{In} for specified P_{Out} ; duty cycle = 12.5%, period = 4.6 ms

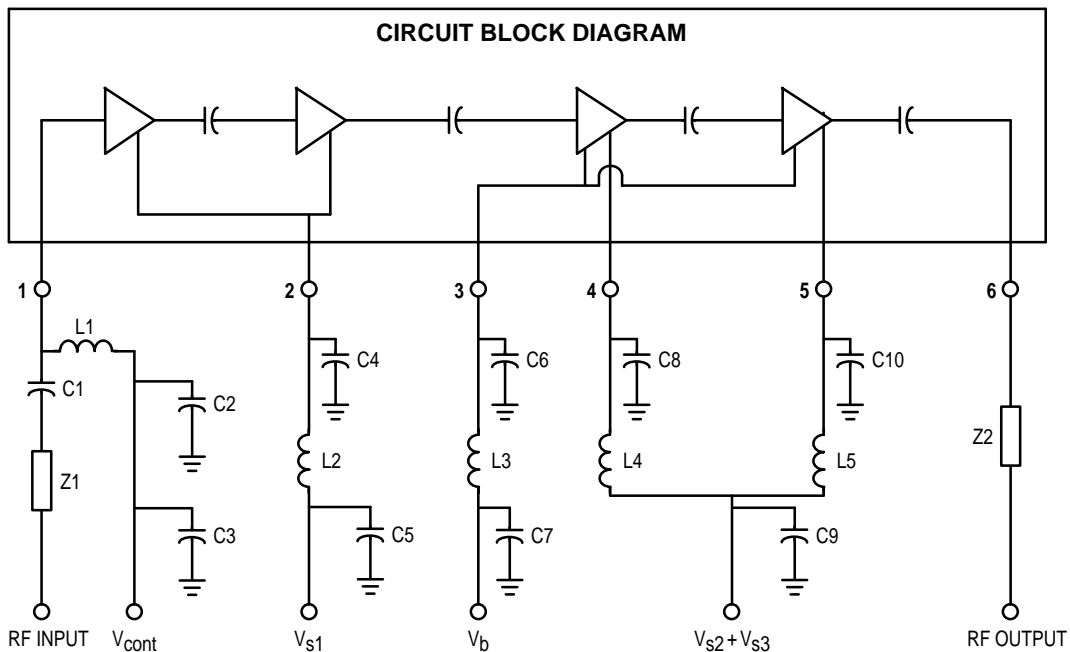

PIN DESIGNATIONS:

- Pin 1 — RF Input Power @ 0 dBm and Control Voltage @ 0–3.0 Vdc
- Pin 2 — First and Second Stage Collector Supply Voltage @ 7.2 Vdc
- Pin 3 — Trickle Base Bias Voltage @ 5.0 Vdc
- Pin 4 — Third Stage Collector Supply Voltage @ 7.2 Vdc
- Pin 5 — Fourth Stage Collector Supply Voltage @ 7.2 Vdc
- Pin 6 — RF Output Power @ 3.5 W

ELEMENT VALUES:

- $C1=C2 = 0.018 \mu\text{F}$
- $C4=C6=C8=C10 = 0.1 \mu\text{F}$
- $C3=C5=C7=C9 = 1.0 \mu\text{F}$ Tant.
- $L1-L3 = 0.29 \mu\text{H}$ Choke
- $L4, L5 = 0.15 \mu\text{H}$ Choke
- $Z1, Z2 = 50$ Ohm Microstrip

Figure 1. Test Circuit Diagram — MHW903/953

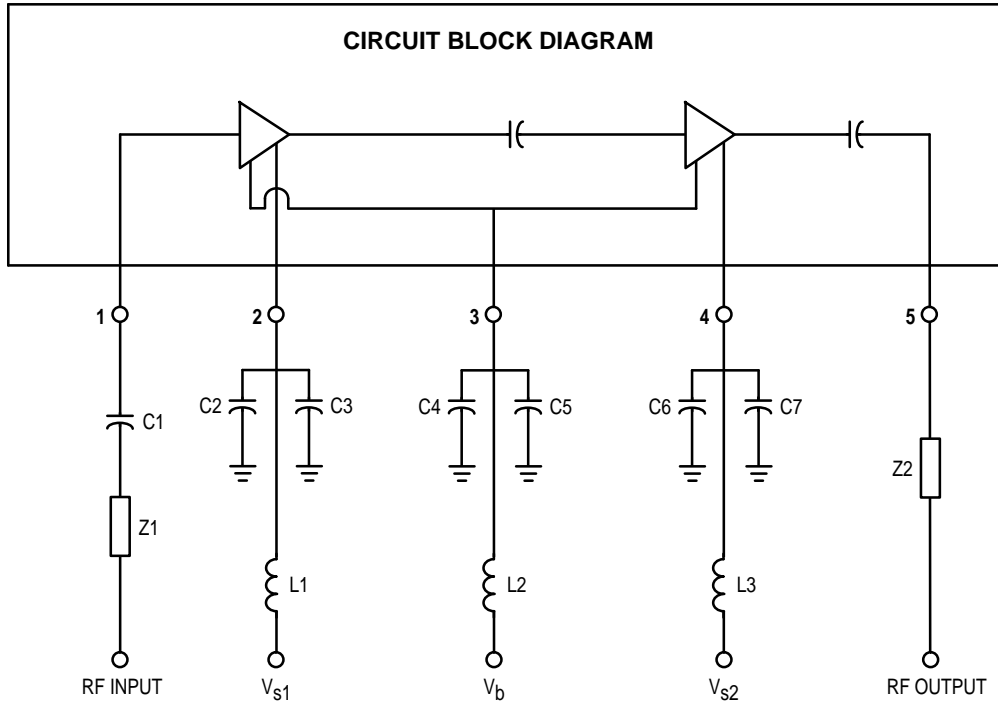

PIN DESIGNATIONS:

- Pin 1 — RF Input Power @ 20 dBm Max Adjust for Output Power
- Pin 2 — First Stage Collector Voltage @ 7.2 Vdc
- Pin 3 — Trickle Bias Voltage @ 4.5 Vdc
- Pin 4 — Third Stage Collector Supply @ 7.2 Vdc
- Pin 5 — RF Output Power @ 3.5 W Nominal

ELEMENT VALUES:

- C1=C2=C4=C6= 0.018 μ F
- C3=C5=C7= 2.2 μ F
- L1, L2 = 0.29 μ H
- L3 = 0.2 μ H
- Z1, Z2 = 50 Ohm Microstrip

Figure 2. Test Circuit Diagram — MHW954

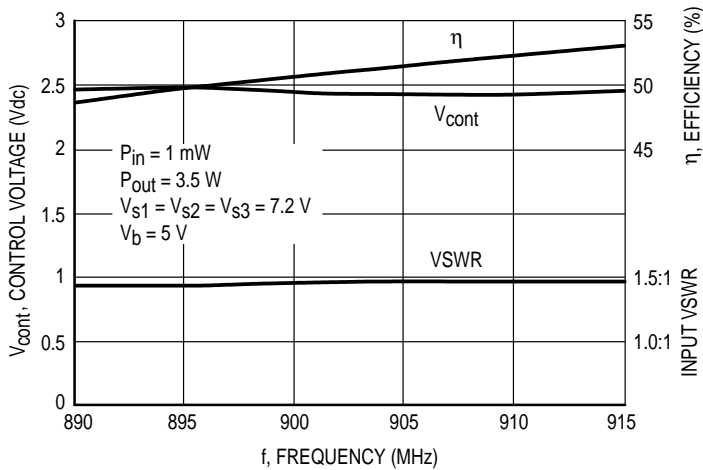

Figure 3. Control Voltage, Efficiency and Input VSWR versus Frequency

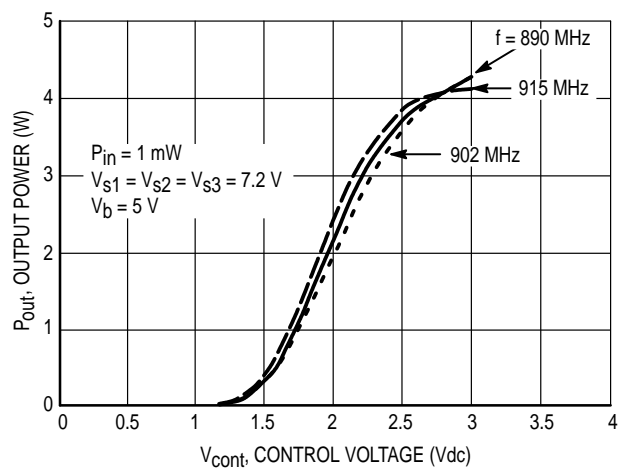

Figure 4. Output Power versus Control Voltage

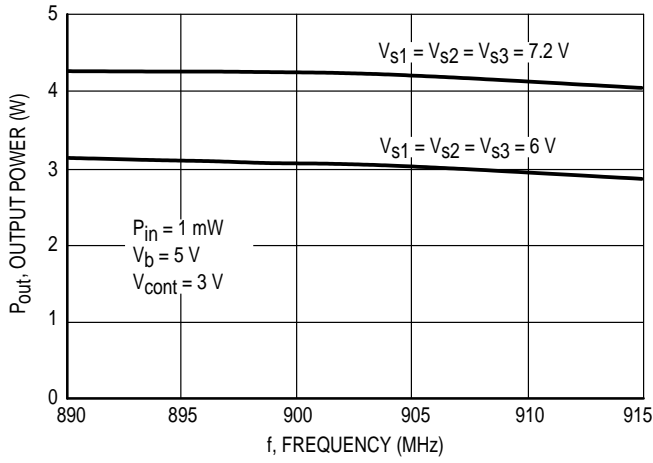

Figure 5. Output Power versus Frequency

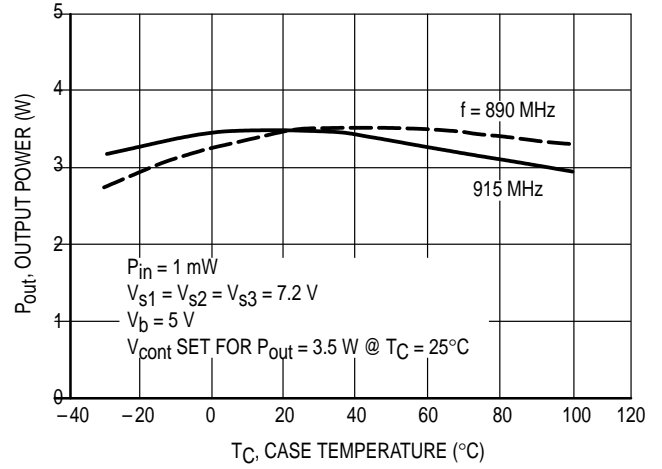

Figure 6. Output Power versus Case Temperature

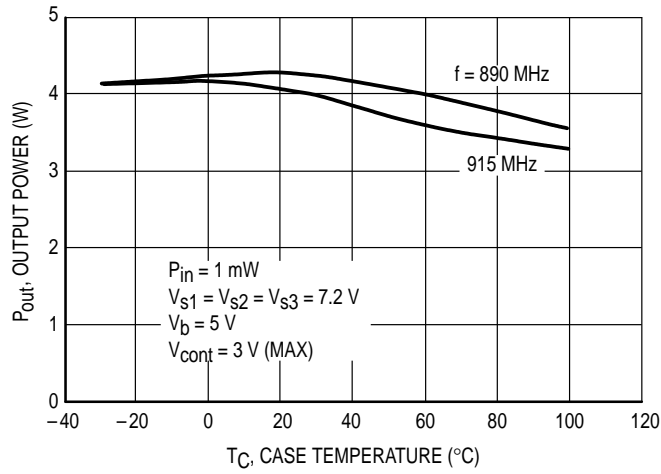

Figure 7. Output Power versus Case Temperature at Maximum Control Voltage

APPLICATIONS INFORMATION

NOMINAL OPERATION

All electrical specifications are based on the nominal conditions of $V_{S1} = V_{S2} = V_{S3} = 7.2$ Vdc (Pins 2, 4, 5) and $V_b = 5.0$ Vdc (Pin 3) for MHW903/953. Nominal conditions are $V_{S1} = V_{S2} = 7.2$ Vdc (Pins 2 and 4) and $V_b = 4.5$ Vdc (Pin 3) for MHW954. With these conditions, maximum current density on any device is 1.5×10^5 A/cm² and maximum die temperature is 165°C. While the modules are designed to have excess gain margin with ruggedness, operation of these units outside the published specifications is not recommended unless prior communications regarding intended use have been made with the factory representative.

GAIN CONTROL

The module output power should be limited to specified value. The preferred method of power control for the MHW903/953 is to fix $V_{S1} = V_{S2} = V_{S3} = 7.2$ Vdc, $V_b = 5.0$ Vdc, P_{in} (Pin 1) at 1.0 mW, and vary V_{cont} (Pin 1) voltage. For the MHW954, fix $V_{S1} = V_{S2} = 7.2$ Vdc and $V_b = 4.5$ Vdc; then vary P_{in} (Pin 1) to control P_{out} (Pin 5).

DECOUPLING

Due to the high gain of the four stages and the module size limitation, external decoupling networks require careful consideration, Pins 2, 3, 4 and 5 are internally bypassed with a 0.018 μ F chip capacitor which is effective for frequencies from

5.0 MHz through 940 MHz. For bypassing frequencies below 5.0 MHz, networks equivalent to that shown in Figure 1 are recommended. Inadequate decoupling will result in spurious outputs at certain operating frequencies and certain phase angles of input and output VSWR.

MOUNTING CONSIDERATIONS

For the MHW903 Series module, mounting is generally accomplished by soldering the flange to a suitable heat sink. This can be done with a low temperature solder such as 52% In, 48% Sn and type "R" Flux which liquifies below 150°C. Under no circumstances should the MHW903 Series modules be heated to a temperature greater than $\approx 165^\circ\text{C}$. Internal construction of the module has been achieved using 36% Tin, 62% lead, 2% silver solder which liquifies at 179–180°C.

The modules are NOT hermetic. Do not immerse a module in a flux cleaning solution or other liquids under any circumstances.

LOAD MISMATCH

During final test each module is load mismatch tested in a fixture having the identical decoupling networks described in Figure 1. Electrical conditions are $V_{S1} = V_{S2} = V_{S3} = 9.0$ Vdc (Pins 2, 4, 5), and $V_b = 5.0$ Vdc (Pin 3), $P_{in} = 2.0$ mW (12.5% duty cycle, 4.6 ms period), VSWR equal to 10:1, and output power equal to 4.5 watts.

PACKAGE DIMENSIONS

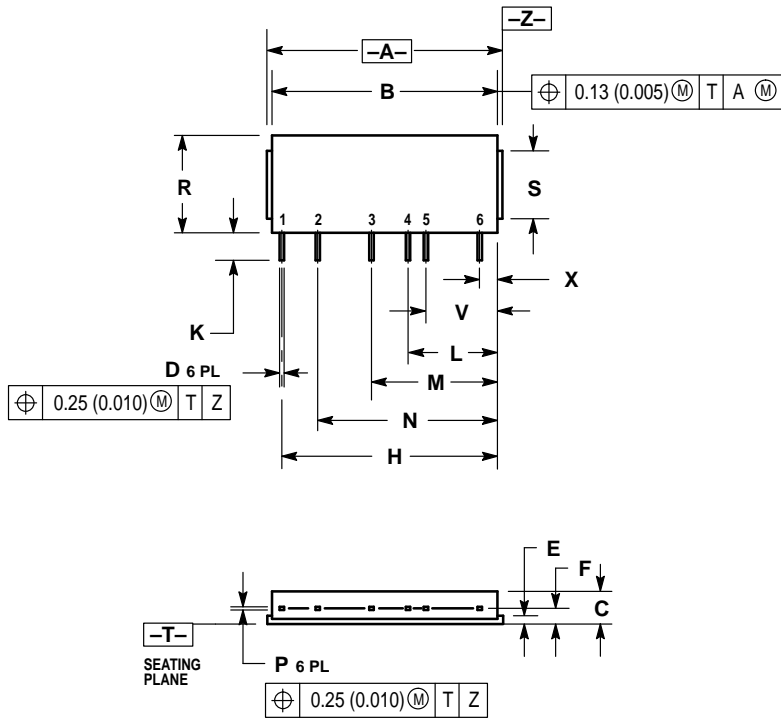

- NOTES:
3. DIMENSIONING AND TOLERANCING PER ANSI Y14.5M, 1982.
 4. CONTROLLING DIMENSION: INCH.
 5. DIMENSION F TO CENTER OF LEADS.
 6. DIMENSIONS B AND R ARE MEASURED AT THE COVER CORNERS. SIZE REDUCTION BY INWARD BOWING OR BY DRAFT ANGLE ARE EXCLUDED.

DIM	INCHES		MILLIMETERS	
	MIN	MAX	MIN	MAX
A	1.290	1.305	32.77	33.14
B	1.257	1.277	31.93	32.44
C	0.160	0.177	4.06	4.57
D	0.018	0.022	0.46	0.55
E	0.035	0.045	0.89	1.14
F	0.075	0.095	1.91	2.41
H	1.205 BSC		30.61 BSC	
K	0.100	—	2.54	—
L	0.505 BSC		12.83 BSC	
M	0.705 BSC		17.91 BSC	
N	1.005 BSC		25.53 BSC	
P	0.008	0.012	0.21	0.30
R	0.535	0.555	13.59	14.10
S	0.375	0.390	9.53	9.90
V	0.405 BSC		10.29 BSC	
X	0.105 BSC		2.67 BSC	

- STYLE 1:
- PIN 1. RF INPUT/V CONT
 - DC TERMINAL, VS1
 - DC TERMINAL, VB
 - DC TERMINAL, VS2
 - DC TERMINAL, VS3
 - RF OUTPUT
- CASE: GROUND

**CASE 413A-02
ISSUE D
MHW903**

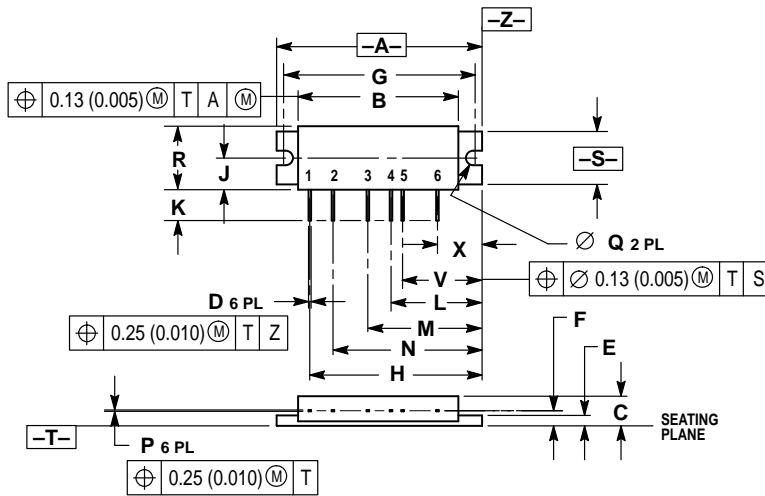

- NOTES:
1. DIMENSIONING AND TOLERANCING PER ANSI Y14.5M, 1982.
 2. CONTROLLING DIMENSION: INCH.
 3. DIMENSION F TO CENTER OF LEADS.

DIM	INCHES		MILLIMETERS	
	MIN	MAX	MIN	MAX
A	1.760	1.780	44.71	45.21
B	1.370	1.390	34.80	35.30
C	0.245	0.265	6.23	6.73
D	0.018	0.022	0.46	0.55
E	0.080	0.100	2.04	2.54
F	0.130 BSC		3.30 BSC	
G	1.650 BSC		41.91 BSC	
H	1.485 BSC		37.72 BSC	
J	0.267	0.278	6.79	7.09
K	0.177	0.217	4.50	5.51
L	0.785 BSC		19.94 BSC	
M	0.985 BSC		25.02 BSC	
N	1.285 BSC		32.64 BSC	
P	0.008	0.012	0.21	0.30
Q	0.120	0.130	3.05	3.30
R	0.535	0.555	13.59	14.09
S	0.445	0.465	11.31	11.81
V	0.685 BSC		17.40 BSC	
X	0.385 BSC		9.78 BSC	

- STYLE 1:
- PIN 1. RF INPUT/V CONT
 - VS1
 - Vb
 - VS2
 - VS3
 - RF OUTPUT
- CASE: GROUND

**CASE 301V-02
ISSUE D
MHW953**

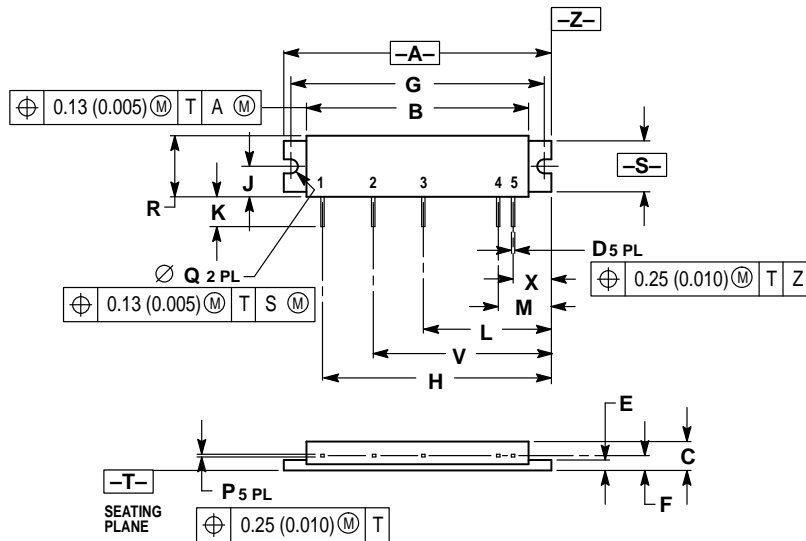

- NOTES:
1. DIMENSIONING AND TOLERANCING PER ANSI Y14.5M, 1982.
 2. CONTROLLING DIMENSION: INCH.
 3. DIMENSION F TO CENTER OF LEADS.

DIM	INCHES		MILLIMETERS	
	MIN	MAX	MIN	MAX
A	1.970	1.990	50.04	50.55
B	1.570	1.590	39.88	40.39
C	0.245	0.265	6.23	6.73
D	0.018	0.022	0.46	0.56
E	0.100	0.115	2.54	2.92
F	0.147 BSC		3.73 BSC	
G	1.860 BSC		47.24 BSC	
H	1.625 BSC		41.28 BSC	
J	0.267	0.278	6.78	7.06
K	0.177	0.217	4.50	5.51
L	0.825 BSC		20.96 BSC	
M	0.425 BSC		10.80 BSC	
P	0.008	0.012	0.20	0.30
Q	0.120	0.130	3.05	3.30
R	0.535	0.555	13.59	14.10
S	0.445	0.465	11.30	11.81
V	1.225 BSC		31.12 BSC	
X	0.325 BSC		8.26 BSC	

- STYLE 1:
- PIN 1: RF INPUT
 - DC TERMINAL, Vs1
 - DC TERMINAL, Vb
 - DC TERMINAL, Vs2
 - RF OUTPUT

**CASE 301Y-02
ISSUE C
MHW954**

Motorola reserves the right to make changes without further notice to any products herein. Motorola makes no warranty, representation or guarantee regarding the suitability of its products for any particular purpose, nor does Motorola assume any liability arising out of the application or use of any product or circuit, and specifically disclaims any and all liability, including without limitation consequential or incidental damages. "Typical" parameters can and do vary in different applications. All operating parameters, including "Typicals" must be validated for each customer application by customer's technical experts. Motorola does not convey any license under its patent rights nor the rights of others. Motorola products are not designed, intended, or authorized for use as components in systems intended for surgical implant into the body, or other applications intended to support or sustain life, or for any other application in which the failure of the Motorola product could create a situation where personal injury or death may occur. Should Buyer purchase or use Motorola products for any such unintended or unauthorized application, Buyer shall indemnify and hold Motorola and its officers, employees, subsidiaries, affiliates, and distributors harmless against all claims, costs, damages, and expenses, and reasonable attorney fees arising out of, directly or indirectly, any claim of personal injury or death associated with such unintended or unauthorized use, even if such claim alleges that Motorola was negligent regarding the design or manufacture of the part. Motorola and  are registered trademarks of Motorola, Inc. Motorola, Inc. is an Equal Opportunity/Affirmative Action Employer.

Literature Distribution Centers:

USA: Motorola Literature Distribution; P.O. Box 20912; Phoenix, Arizona 85036.

EUROPE: Motorola Ltd.; European Literature Centre; 88 Tanners Drive, Blakelands, Milton Keynes, MK14 5BP, England.

JAPAN: Nippon Motorola Ltd.; 4-32-1, Nishi-Gotanda, Shinagawa-ku, Tokyo 141, Japan.

ASIA PACIFIC: Motorola Semiconductors H.K. Ltd.; Silicon Harbour Center, No. 2 Dai King Street, Tai Po Industrial Estate, Tai Po, N.T., Hong Kong.



MOTOROLA

ML110001D