

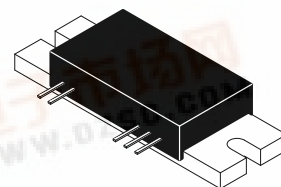
# UHF Silicon FET Power Amplifier

Designed specifically for the Pan European digital 8.0 watt, GSM mobile radio. The MHW913 is capable of wide power range control, operates from a 12.5 volt supply and requires less than 100 mW of RF input power.

- Specified 12.5 V Characteristics
  - RF Input Power  $\leq$  100 mW (20 dBm)
  - RF Output Power = 14 W
  - Minimum Gain = 21.5 dB
  - Minimum Efficiency = 35%
- 50  $\Omega$  Input/Output Impedance
- Guaranteed Stability and Ruggedness
- Epoxy Glass Substrate Eliminates Possibility of Substrate Fracture
- Circuit board photomaster available upon request by contacting RF Tactical Marketing in Phoenix, AZ.

**MHW913**

**14 WATT**  
**880–915 MHz**  
**RF POWER AMPLIFIER**



CASE 301AB-02, STYLE 1

## MAXIMUM RATINGS (Flange Temperature = 25°C)

Rating	Symbol	Value	Unit
DC Supply Voltage	$V_{bias}$ , $V_{S2}$ , $V_{S3}$	5.0 15.6	Volt
RF Input Power	$P_{in}$	200	mW
RF Output Power	$P_{out}$	15	Watt
Storage Temperature	$T_C$	-30 to +100	°C
Operating Case Temperature	$T_{stg}$	-30 to +100	°C

## ELECTRICAL CHARACTERISTICS ( $V_{S2} = V_{S3} = 12.5$ Vdc, $V_{bias} = 4.8$ Vdc, $T_C = 25^\circ\text{C}$ , 50 $\Omega$ system, unless otherwise noted)

Characteristic	Symbol	Min	Max	Unit
Frequency Range	BW	880	915	MHz
Efficiency ( $P_{out} = 14$ W) (1)	$\eta$	35	—	%
Power Gain ( $P_{out} = 14$ W) (1)	$G_p$	21.5	—	dB
Harmonic Output ( $P_{out} = 14$ W Reference) (1)	$2f_o$ $3f_o$	—	-30 -35	dBc
Input VSWR ( $P_{out} = 14$ W) (1)	$VSWR_{in}$	—	3:1	
Linearity — % AM in Output $P_{out} = 0.02$ to 14 W; 135 kHz, 1.0% AM on Input (1)	—	—	6.0	%
Output Power at Decreased Voltage ( $P_{in} = 100$ mW, $V_{S2} = V_{S3} = 10.8$ Vdc) (1)	$P_{out}$	10	—	Watt

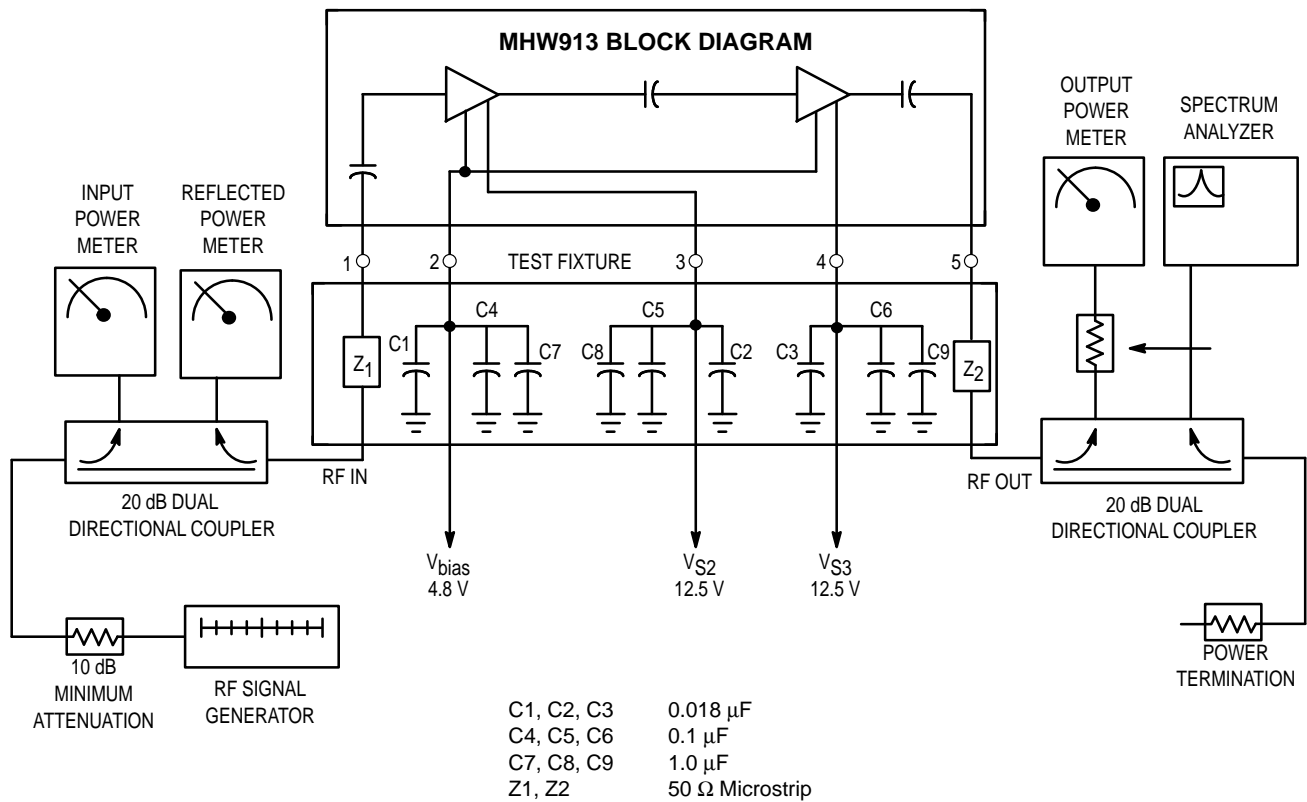
(1) Adjust  $P_{in}$  for specified  $P_{out}$ .

(continued)

**ELECTRICAL CHARACTERISTICS (continued)** ( $V_{S2} = V_{S3} = 12.5\text{ V}$ ,  $V_{bias} = 4.8\text{ V}$ ,  $T_C = 25^\circ\text{C}$ ,  $50\ \Omega$  system, unless otherwise noted)

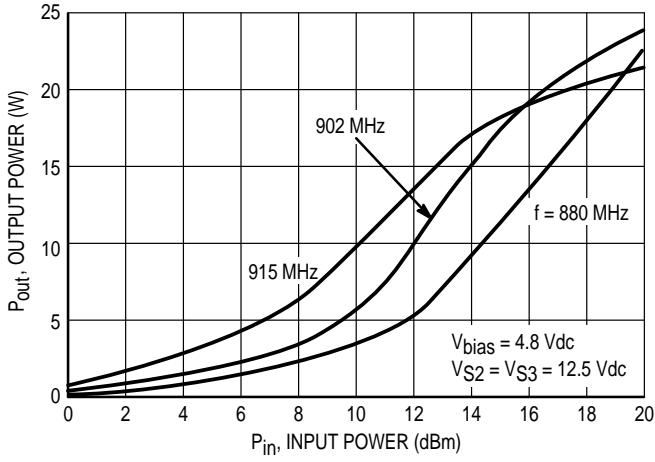
Load Mismatch Stress ( $V_{supply} = 15.6\text{ Vdc}$ , $P_{out} = 15\text{ W}$ ; Load VSWR = 10:1, All Phase Angles) (1)	—	No degradation in output power		
Stability ( $V_{supply} = 10.8$ to $16\text{ Vdc}$ ; $P_{out} = 0.03$ to $14\text{ W}$ ; Load VSWR = 6:1, All Phase Angles) (1)	—	All spurious outputs more than 60 dB below desired signal		
Quiescent Current (With No RF Applied) ( $V_{S2} = V_{S3} = 12.5\text{ Vdc}$ , $V_{bias} = 4.8\text{ Vdc}$ )	$I_{sq}$	—	500	mA
Leakage Current ( $P_{in} = 0\text{ mW}$ , $V_{S2} = V_{S3} = 12.5\text{ Vdc}$ , $V_b = 0\text{ Vdc}$ )	$I_L$	—	0.6	mA
Bias $P_{in}$ Current ( $P_{out} = 14\text{ W}$ ) (1)	$I_{bias}$	—	0.8	mA
Noise Power (In 30 kHz Bandwidth, 20 MHz above $f_0$ ) ( $P_{out} = 0.03$ to $14\text{ W}$ , $V_{S2} = V_{S3} = 10.8$ to $15.6\text{ Vdc}$ ; $V_{bias} = 4.8\text{ Vdc}$ ) (1)	—	—	-70	dBm

(1) Adjust  $P_{in}$  for specified  $P_{out}$ .

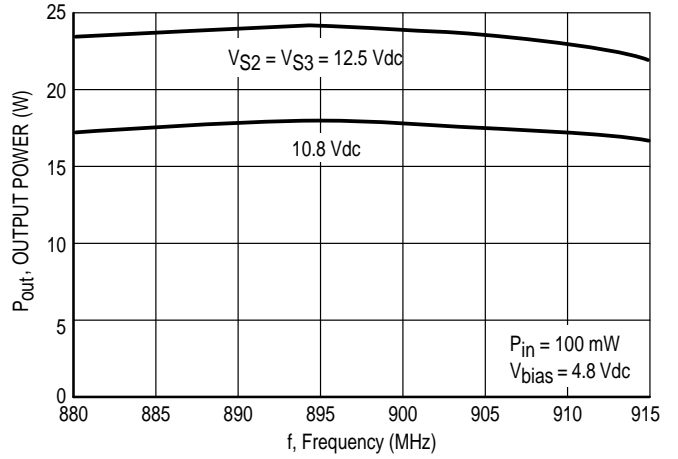


**Figure 1. MHW913 Test Circuit Diagram**

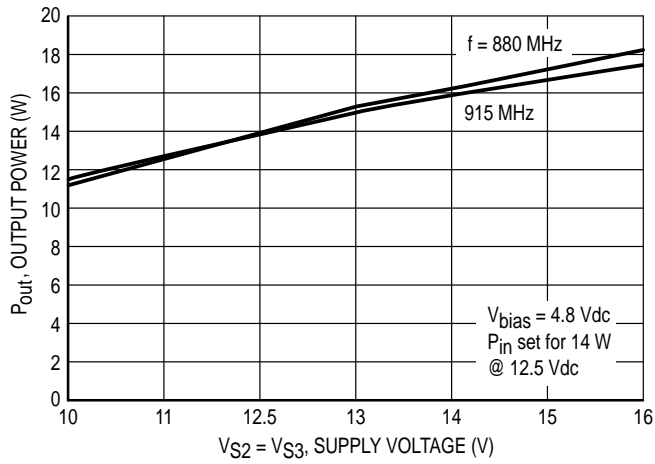
## Typical Characteristics



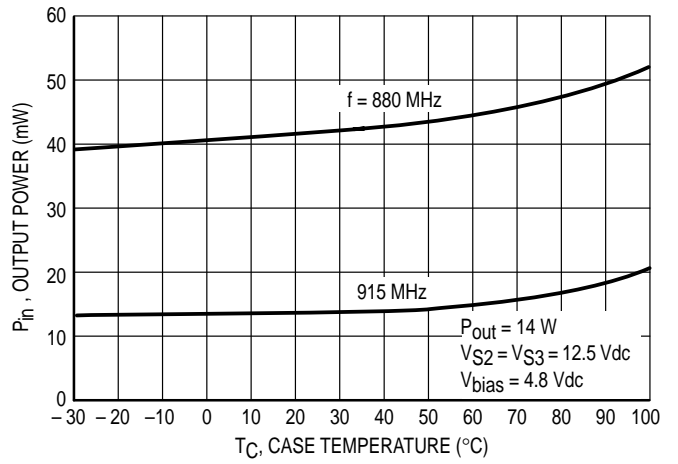
**Figure 2. Output Power versus Input Power**



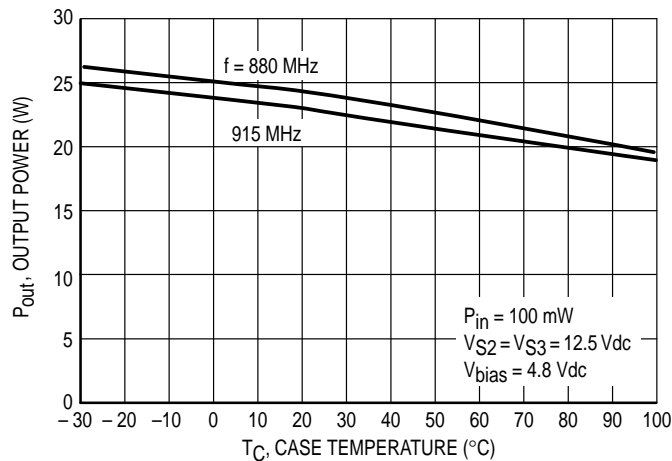
**Figure 3. Output Power versus Frequency**



**Figure 4. Output Power versus Supply Voltage**

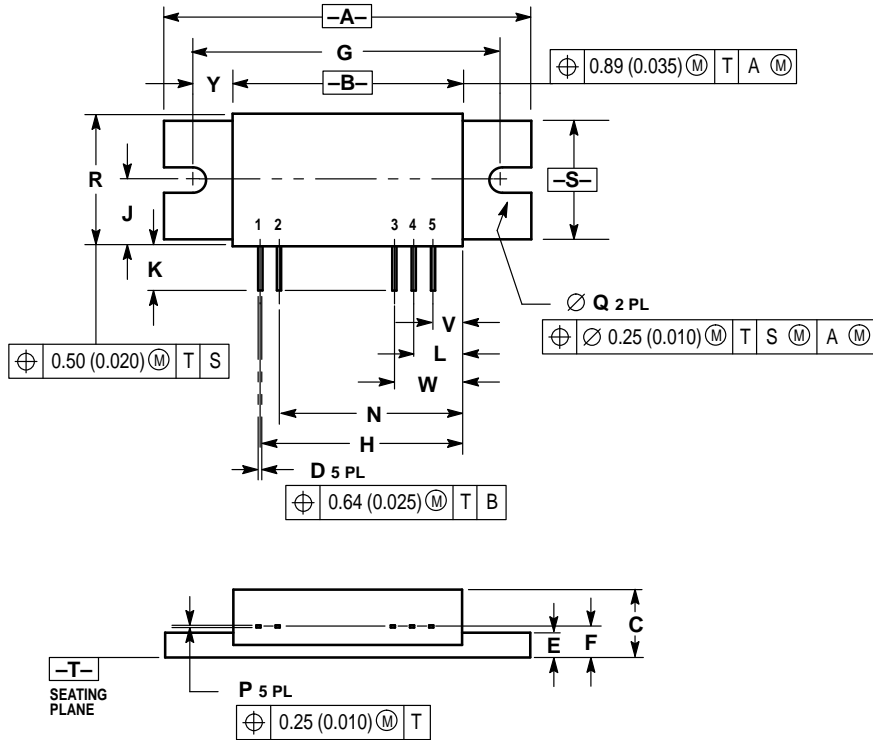


**Figure 5. Input Power versus Case Temperature for  $P_{out} = 14\text{ W}$**



**Figure 6. Output Power versus Case Temperature for Maximum Input Power**

## PACKAGE DIMENSIONS



- NOTES:
1. DIMENSIONING AND TOLERANCING PER ANSI Y14.5M, 1982.
  2. CONTROLLING DIMENSION: INCH.
  3. DIMENSION F TO CENTER OF LEADS.
  4. REF INDICATES NON-CONTROLLED DIMENSION FOR REFERENCE USE ONLY.

DIM	INCHES		MILLIMETERS	
	MIN	MAX	MIN	MAX
A	1.890	1.910	48.01	48.51
B	1.170	1.190	29.72	30.23
C	0.350	0.376	8.89	9.55
D	0.018	0.022	0.46	0.56
E	0.120	0.135	3.05	3.43
F	0.165 BSC		4.19 BSC	
G	1.600 BSC		40.64 BSC	
H	1.055 BSC		26.80 BSC	
J	0.336	0.360	8.53	9.14
K	0.225	—	5.72	—
L	0.255 BSC		6.48 BSC	
N	0.955 BSC		24.26 BSC	
P	0.008	0.012	0.20	0.31
Q	0.151	0.161	3.84	4.09
R	0.685	0.705	17.40	17.91
S	0.598	0.612	15.19	15.55
V	0.155 BSC		3.94 BSC	
W	0.355 BSC		9.02 BSC	
Y	0.210 REF		5.33 REF	

- STYLE 1:  
 PIN 1: RF INPUT  
 2. +DC (BIAS)  
 3. +DC (SUPPLY)  
 4. +DC (SUPPLY)  
 5. RF OUTPUT  
 CASE: GROUND

### CASE 301AB-02 ISSUE G

Motorola reserves the right to make changes without further notice to any products herein. Motorola makes no warranty, representation or guarantee regarding the suitability of its products for any particular purpose, nor does Motorola assume any liability arising out of the application or use of any product or circuit, and specifically disclaims any and all liability, including without limitation consequential or incidental damages. "Typical" parameters which may be provided in Motorola data sheets and/or specifications can and do vary in different applications and actual performance may vary over time. All operating parameters, including "Typicals" must be validated for each customer application by customer's technical experts. Motorola does not convey any license under its patent rights nor the rights of others. Motorola products are not designed, intended, or authorized for use as components in systems intended for surgical implant into the body, or other applications intended to support or sustain life, or for any other application in which the failure of the Motorola product could create a situation where personal injury or death may occur. Should Buyer purchase or use Motorola products for any such unintended or unauthorized application, Buyer shall indemnify and hold Motorola and its officers, employees, subsidiaries, affiliates, and distributors harmless against all claims, costs, damages, and expenses, and reasonable attorney fees arising out of, directly or indirectly, any claim of personal injury or death associated with such unintended or unauthorized use, even if such claim alleges that Motorola was negligent regarding the design or manufacture of the part. Motorola and are registered trademarks of Motorola, Inc. Motorola, Inc. is an Equal Opportunity/Affirmative Action Employer.

Mfax is a trademark of Motorola, Inc.

**How to reach us:**

**USA/EUROPE/Locations Not Listed:** Motorola Literature Distribution;  
 P.O. Box 5405, Denver, Colorado 80217. 303-675-2140 or 1-800-441-2447

**JAPAN:** Nippon Motorola Ltd.: SPD, Strategic Planning Office, 4-32-1,  
 Nishi-Gotanda, Shinagawa-ku, Tokyo 141, Japan. 81-3-5487-8488

**Mfax™:** RMFAX0@email.sps.mot.com – TOUCHTONE 602-244-6609  
 – US & Canada ONLY 1-800-774-1848

**ASIA/PACIFIC:** Motorola Semiconductors H.K. Ltd.; 8B Tai Ping Industrial Park,  
 51 Ting Kok Road, Tai Po, N.T., Hong Kong. 852-26629298

**INTERNET:** <http://motorola.com/sps>

