



MIC1832

μ P Supervisory Circuit

Description

The MIC1832 is a multifunction circuit which monitors microprocessor activity, external reset and power supplies in microprocessor based systems. The circuit functions include a watchdog timer, power supply monitor, microprocessor reset, and manual pushbutton reset input.

The power supply line is monitored with a comparator and an internal voltage reference. RST is forced low when an out-of-tolerance condition exists and remains asserted for at least 250ms after V_{CC} rises above the threshold voltage (2.55V or 2.88V). The \overline{RST} pin will remain logic low with V_{CC} as low as 1.4V.

The Watchdog input (\overline{ST}) monitors μ P activity and will assert RST if no μ P activity has occurred within the watchdog timeout period. The watchdog timeout period is selectable with a nominal periods of 150, 600, or 1200 milliseconds.

Typical Applications

- Automotive Systems
- Intelligent Instruments
- Critical Microprocessor Power Monitoring
- Battery Powered Computers
- Controllers

Ordering Information

Part	Package	Temp. Range
MIC1832N	8-Lead PDIP	-40°C to +85°C
MIC1832M	8-Lead SOIC	-40°C to +85°C

Pin Configuration

Top View

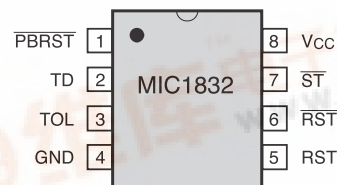

MIC1832N - 8 Lead Plastic DIP Package
MIC1832M - 8 Lead Plastic SOIC Package

Features

- Power OK/Reset Time Delay, 250ms min.
- Watchdog Timer, 150ms, 600ms, or 1.2s typical
- Precision Supply Voltage Monitor, Select Between 5% or 10% of Supply Voltage
- Available in 8-pin Surface Mount (SO)
- Debounced External Reset Input
- Low Supply Current, < 18 μ A Typ.

Typical Operating Circuit

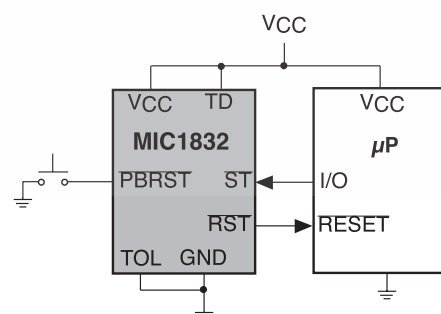

MIC1832 μ P Supervisory Circuit

Absolute Maximum Ratings

Terminal Voltage	
V _{CC}	-0.3V to 7.0V
All Other Inputs	-0.3V to (V _{CC} + 0.3V)
Input Current	
V _{CC}	250mA
Gnd, All Other Inputs	25mA

Operating Temperature Range	
MIC1832	-40°C to 85°C
Storage Temperature Range	-65°C to 150°C
Lead Temperature (Soldering - 10 sec.)	300°C
Power Dissipation	700mW

Stresses above those listed under ABSOLUTE MAXIMUM RATINGS may cause permanent device failure. Functionality at or above these limits is not implied. Exposure to absolute maximum ratings for extended periods may affect device reliability. Operating ranges define those limits between which the functionality of the device is guaranteed.

Electrical Characteristics

V_{CC} = 3 to 5.5 V, T_A = Operating Temperature Range, unless otherwise noted.

Parameter	Conditions	Min	Typ	Max	Units
Supply Voltage Range	V _{CC}			5.5	V
Supply Current	I _{CC} @ V _{CC} = 5V (See Note 1)		18	30	μ A
	I _{CC} @ V _{CC} = 3.3V (See Note 1)		15	25	μ A
\overline{ST} and \overline{PBRST} Input Levels	V _{IH} (See Note 2)	2.0		V _{CC} + 0.3	V
	V _{IH} (See Note 3)	V _{CC} - 0.4		V _{CC} + 0.3	V
	V _{IL}	-0.3		0.5	
Input Leakage, \overline{ST} (See Note 4)	I _{IL}			± 1	μ A
Output Voltage, \overline{RST} , RST	I _{SOURCE} = 350 μ A, V _{CC} = 3.3V	2.4			V
Output Voltage, \overline{RST} , RST	I _{SINK} = 10mA, V _{CC} = 3.3V			0.4	V
Output Voltage, \overline{RST}	V _{CC} = 1.4V, I _{SINK} = 50 μ A			0.3	V
V _{CC} 5% Trip Point (Reset Threshold Voltage)	TOL = Gnd	2.80	2.88	2.97	V
V _{CC} 10% Trip Point (Reset Threshold Voltage)	TOL = V _{CC}	2.47	2.55	2.64	V
Input Capacitance, \overline{ST} , TOL	C _{IN} (See Note 5)			5	pF
Output Capacitance, \overline{RST} , RST	C _{OUT} (See Note 5)			7	pF

MIC1832 μ P Supervisory Circuit

A.C. Electrical Characteristics

$V_{CC} = 3$ to 5.5 V, $T_A =$ Operating Temperature Range, unless otherwise noted.

Parameter	Conditions	Min	Typ	Max	Units
\overline{PBRST} Min. Pulse Width, t_{PB}	$\overline{PBRST} = V_{IL}$ (see note 6)	20			ms
\overline{PBRST} Delay, t_{PBD}		1	4	20	ms
Reset Active Time, t_{RST}		250	610	1000	ms
\overline{ST} Pulse Width, t_{ST}		20			ns
\overline{ST} Timeout Period, t_{TD}	TD = 0V TD = Open TD = V_{CC}	62.5 250 500	150 600 1200	250 1000 2000	ms
V_{CC} Fall Time, t_F		40			μ s
V_{CC} Rise Time, t_R		0			ns
V_{CC} Detect to \overline{RST} Low and RST High, t_{RPD}	V_{CC} Falling (see note 7)		5	8	μ s
V_{CC} Detect to \overline{RST} High and RST Low, t_{RPU}	V_{CC} Rising	250	610	1000	ms

Note 1: I_{CC} is measured with \overline{PBRST} and all outputs open and inputs within 0.5V of supply rails.

Note 2: Measured with $V_{CC} \geq 2.7$ V.

Note 3: Measured with $V_{CC} < 2.7$ V.

Note 4: \overline{PBRST} has an internal pull-up resistor to V_{CC} (typ. 40k Ω).

Note 5: Guaranteed by design at $T_A = 25^\circ$ C.

Note 6: \overline{PBRST} must be held low for a minimum of 20ms to guarantee a reset.

Note 7: V_{CC} falling at 8.5mv/ μ s.

MIC1832 μ P Supervisory Circuit

Pin Functions

- Pin 1: **PBRST** - Pushbutton reset input. This input is debounced and can be driven with external logic signals or by means of a mechanical pushbutton to actively force a reset. All pulses less than 1ms in duration on the PBRST pin are ignored, whereas, any pulse with a duration of 20ms or greater is guaranteed to cause a reset. PBRST has an internal pull-up resistor to V_{CC} of 40k Ω typical.
- Pin 2: **TD** - Time delay input. This input selects the timebase used by the watchdog timer. When TD = 0V, the watchdog timeout period is set to a nominal value of 150ms and when TD = open, the watchdog timeout period is set to a nominal value of 600ms and when TD = V_{CC} , the watchdog timeout period is 1.2sec nominally.
- Pin 3: **TOL** - Tolerance select input. Selects whether 5% or 10% of V_{CC} is used as the reset threshold voltage. When TOL = 0V, the 5% tolerance level is selected and when TOL = V_{CC} , a 10% tolerance level is selected.
- Pin 4: **GND** - IC ground pin, 0V reference.
- Pin 5: **RST** - RST is asserted high if either V_{CC} goes below the reset threshold, the watchdog times out or $\overline{\text{PBRST}}$ is pulled low for a minimum of 20ms. RST remains asserted for one reset timeout period after V_{CC} exceeds the reset threshold or after the watchdog times out or after PBRST goes high.
- Pin 6: **RST** - $\overline{\text{RST}}$ is asserted low if either V_{CC} goes below the reset threshold, the watchdog times out or $\overline{\text{PBRST}}$ is pulled low for a minimum of 20ms. $\overline{\text{RST}}$ remains asserted for one reset timeout period after V_{CC} exceeds the reset threshold or after the watchdog times out or after PBRST goes high.
- Pin 7: **ST** - Input to the watchdog timer. If $\overline{\text{ST}}$ does not see a transition from high to low within the watchdog timeout period, RST and $\overline{\text{RST}}$ will be asserted.
- Pin 8: **VCC** - Primary supply input.

MIC1832 μ P Supervisory Circuit

Block Diagram

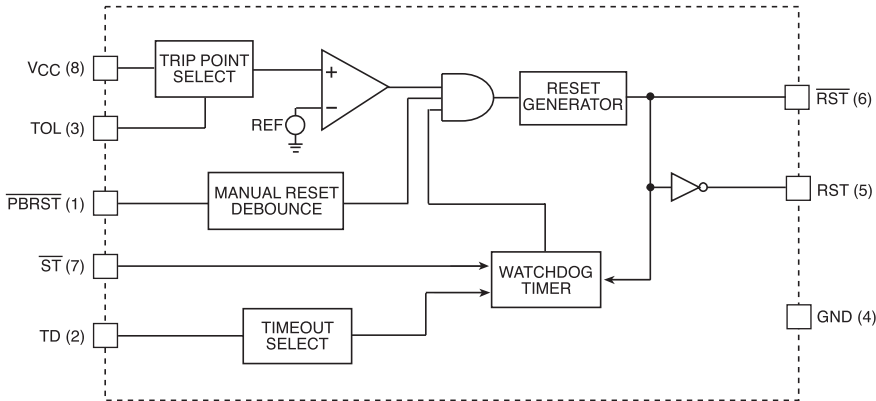

Circuit Description

TD Pin	t_{TD}		
	Min.	Typ.	Max.
Gnd	62.5ms	150ms	250ms
Open	250ms	600ms	1000ms
VCC	500ms	1200ms	2000ms

Table 1. Watchdog Timeout Period

MIC1832 μ P Supervisory Circuit

Circuit Description

Power Monitor

The $\overline{\text{RST}}$ and RST pins are asserted whenever V_{CC} falls below the reset threshold voltage as determined by the TOL pin. A 5% tolerance level (2.88V reset threshold voltage) can be selected by connecting the TOL pin to ground and a 10% tolerance (2.55V reset threshold voltage) can be selected by connecting the TOL pin to V_{CC} . The reset pins will remain asserted for a period of 250ms after V_{CC} has risen above the reset threshold voltage. The reset function ensures the microprocessor is properly reset and powers up into a known condition after a power failure. $\overline{\text{RST}}$ will remain valid with V_{CC} as low as 1.4V.

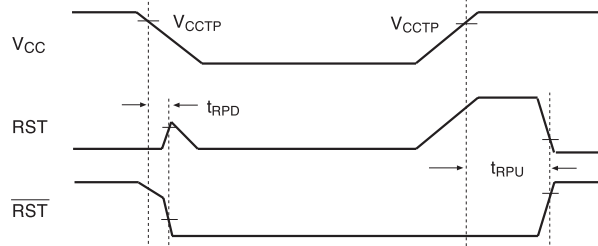
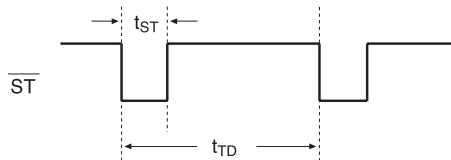

Figure 1. Power-Up/Power-Down Sequence



Note: The maximum time between high-to-low transitions (t_{TD}) on the watchdog input (ST) is determined by the voltage applied to the TD pin. If the watchdog input sees a high-to-low transition prior to the timeout period, the watchdog timer will be reset.

Figure 2. Watchdog Input

Watchdog Timer

The microprocessor can be monitored by connecting the $\overline{\text{ST}}$ pin (watchdog input) to a bus line or I/O line. If a high-to-low transition doesn't occur on the $\overline{\text{ST}}$ pin within the watchdog timeout period (determined by TD pin, see Table 1), the $\overline{\text{RST}}$ and RST pins will be asserted resulting in a microprocessor reset. $\overline{\text{RST}}$ and RST will remain asserted for at least 250ms when this occurs. A minimum pulse of 75ns or any transition high-to-low on the $\overline{\text{ST}}$ pin will reset the watchdog timer. The watchdog timer will be reset if $\overline{\text{ST}}$ sees a valid transition within the watchdog timeout period.

Pushbutton Reset Input

The $\overline{\text{PBRST}}$ input can be driven with a manual pushbutton switch or with external logic signals. The input is internally debounced and requires an active low signal to force the reset outputs into their active states. The $\overline{\text{PBRST}}$ input will recognize any pulse that is 20ms in duration or greater and will ignore all pulses that are less than 1ms in duration.

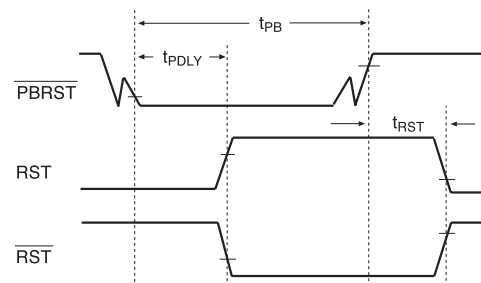

Figure 3. Pushbutton Reset

MIC1832 μ P Supervisory Circuit

Alternate Source Cross Reference Guide

<u>Industry P/N</u>	<u>MIC Direct Replacement</u>
DS1832	MIC1832NC
DS1832S	MIC1832MC

MIC1832 μ P Supervisory Circuit

Packaging Information

M Package, 8-Pin Small Outline

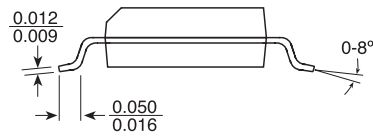
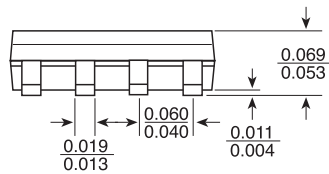
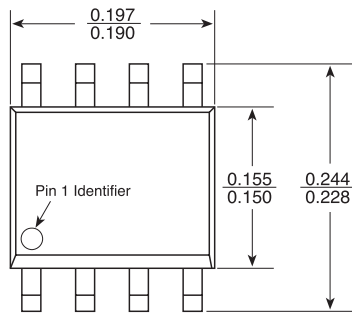

N Package, 8-Pin Plastic Dual-In-Line

