



The Infinite Bandwidth Company™

MIC2145

High Efficiency 2.5W Boost Converter

Final

General Description

The MIC2145 is a small size boost switching regulator that can provide over 2.5W of output power. The input voltage range is between 2.4V to 16V, making the device suitable for one-cell Li-Ion and 3- to 4-cell alkaline/NiCad/NiMH applications. The output voltage of the MIC2145 can be adjusted up to 16V.

The MIC2145 is well suited for portable, space-sensitive applications. Its typical 450kHz operation allows small surface mount external components to be used. The MIC2145 has a low quiescent current of 200µA, and a typical shutdown current of 0.5µA. The MIC2145 is capable of high efficiencies in a small board area.

The MIC2145 features a low-on resistance internal switch that allows it to provide over 2.5W of output power. The peak switch current can be programmed through an external resistor. This allows the user to set the peak switch current at the level where maximum efficiency occurs. It also allows the user to further optimize for efficiency and inductor size by setting the peak current below the level of inductor saturation.

The MIC2145 is available in an MSOP-8 and 3mm×3mm MLF™-10L package with an ambient operating temperature range from -40°C to +85°C.

Features

- 2.4V to 16V input voltage
- Output adjustable to 16V
- Programmable peak current limit
- Soft start
- Up to 450kHz switching frequency
- 0.5µA shutdown current
- 200µA quiescent current
- Capable of 5V/ 500mA output with 3.3V input
- Achieves over 85% efficiency
- Implements low power BOOST, SEPIC, and FLYBACK topologies
- MSOP-8 and 3mm×3mm MLF™-10L

Applications

- Flash LED driver
- LCD bias supply
- White LED driver
- DSL bias supply
- Local 3V to 5V conversion

Ordering Information

Part Number	Voltage	Ambient Temp. Range	Package
MIC2145BMM	Adj	-40°C to +85°C	8-lead MSOP
MIC2145BML	Adj	-40°C to +85°C	3×3 MLF™-10L

Typical Application

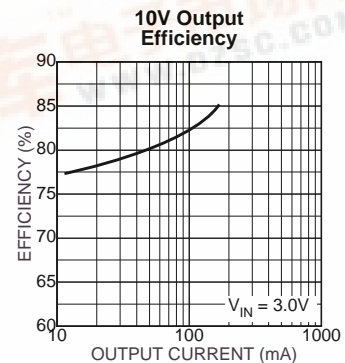
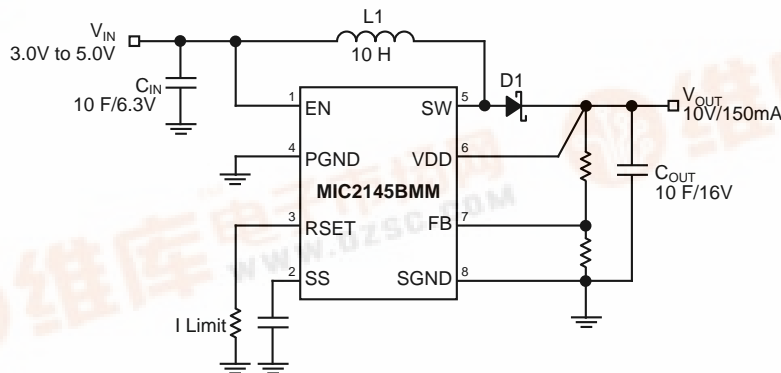

Adjustable Output Boost Converter with Programmable Peak Switch Current



Pin Configuration

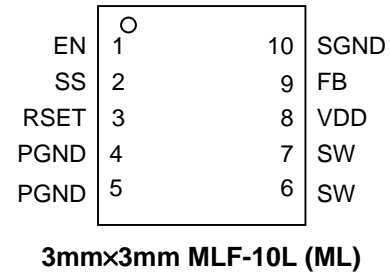
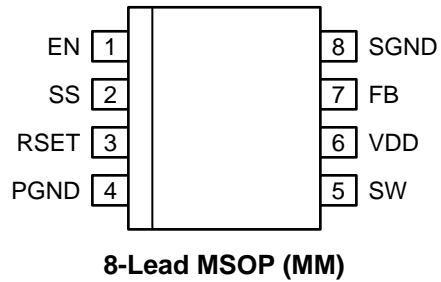

Pin Description

Pin Number MSOP	Pin Number MLF	Pin Name	Pin Function
1	1	EN	Enable (Input): Logic high ($\geq 1.5V$) enables regulator. Logic low ($\leq 0.7V$) shuts down regulator. Do not float.
2	2	SS	Soft Start Capacitor (External Component): Connect external capacitor to ground to control the rise time of the output voltage.
3	3	RSET	Current Limit (External Component): Sets peak current limit of the internal power MOSFET using an external resistor.
4	4, 5	PGND	Power Ground (Return): Internal power MOSFET source.
5	6, 7	SW	Switch Node (Input): Internal power MOSFET drain.
6	8	VDD	Supply (Input): +2.4V to +16V for internal circuitry.
7	9	FB	Feedback (Input): Output voltage sense node.
8	10	SGND	Small Signal Ground (Return): Ground

Absolute Maximum Ratings (Note 1)

Supply Voltage (V_{DD})	18V
Switch Voltage (V_{SW})	18V
Feedback Voltage (V_{FB})	18V
Switch Current (I_{SW})	2A
Enable Voltage (V_{EN}), Note 5	18V
RSET Voltage (V_{RSET})	6V
ESD Rating, Note 3	2kV
Ambient Storage Temperature (T_S)	-65°C to +150°C

Operating Ratings (Note 2)

Supply Voltage (V_{DD})	2.4V to 16V
Switch Voltage (V_{SW})	16V
Ambient Temperature (T_A)	-40°C to +85°C
Junction Temperature (T_J)	-40°C to +125°C
Package Thermal Resistance MSOP	
θ_{JA} (MSOP-8)	206°C/W
θ_{JA} (3mm×3mm MLF-10)	60°C/W

Electrical Characteristics (Note 6)

$V_{DD} = 10V$, $V_{OUT} = 10V$, $I_{OUT} = 100mA$; $T_J = 25^\circ C$, unless otherwise noted, **bold** values indicate $-40^\circ C \leq T_J \leq 125^\circ C$.

Parameter	Condition	Min	Typ	Max	Units
Supply Voltage		2.4		16	V
Shutdown Current	$EN = 0.3V$, $V_{DD} = 10V$, $V_{FB} = 1.35V$		0.5	5	μA
Quiescent Current	$EN = V_{DD}$, $V_{DD} = 10V$, $V_{FB} = 1.35V$		200	300	μA
Feedback Voltage Reference	($\pm 2\%$)	1.058	1.08	1.102	V
	($\pm 3\%$)	1.048		1.112	V
Comparator Hysteresis			18		mV
Feedback Input Current	$V_{FB} = 1.35V$		40		nA
Peak Current Limit	$R_{SET} = 200\Omega$, $V_{DD} = 3.6V$, Note 4		0.8		A
	$R_{SET} = 1k\Omega$, $V_{DD} = 10V$, Note 4		0.9		A
Current Limit Comparator Propagation Delay			500		ns
Switch On-Resistance	$I_{SW} = 150mA$, $V_{DD} = 3.0V$		500	750	$m\Omega$
	$I_{SW} = 1.2A$, $V_{DD} = 10V$		250	400	$m\Omega$
Maximum Off Time			1000		ns
Enable Input Voltage	Logic Low (turn-off)		1.1	0.7	V
	Logic High (turn-on)	1.5	1.1		V
Enable Input Current	$V_{EN} = 0V$	-1	0.01	1	μA
	$V_{EN} = 2V$	-1	0.01	1	μA
Soft Start Current	$V_{EN} = 2V$, $V_{DD} = 3.0V$	-8	-12	-16	μA

Note 1. Exceeding the absolute maximum rating may damage the device.

Note 2. The device is not guaranteed to function outside its operating rating.

Note 3. Devices are ESD sensitive. Handling precautions recommended. Human body model, 1.5K Ω in series with 100pF.

Note 4. The current is measured in a DC mode. Actual peak switching current will be higher due to internal propagation delay of the circuit.

Note 5. $V_{EN} \leq V_{DD}$.

Note 6. Specification for packaged product only.

Typical Characteristics

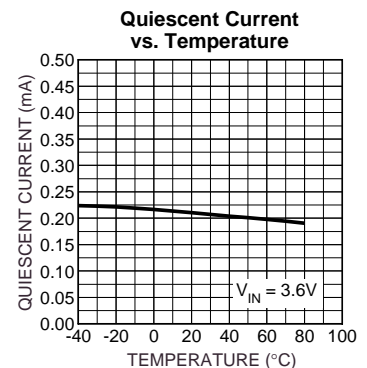
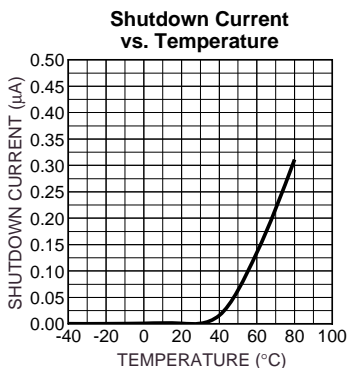
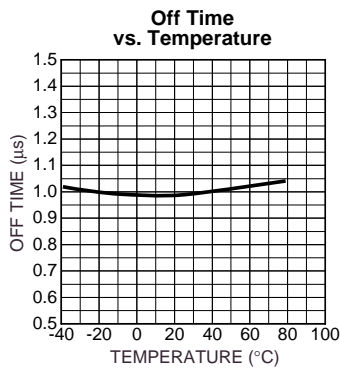
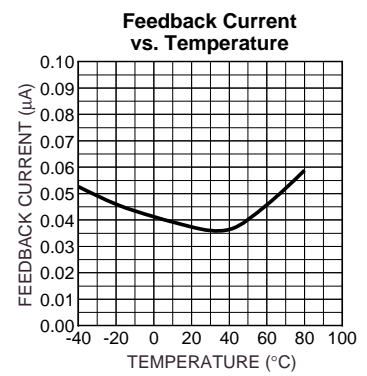
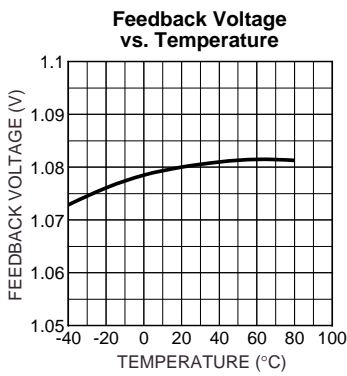
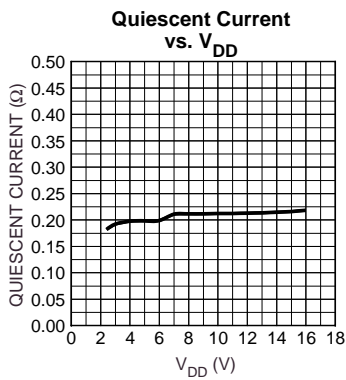
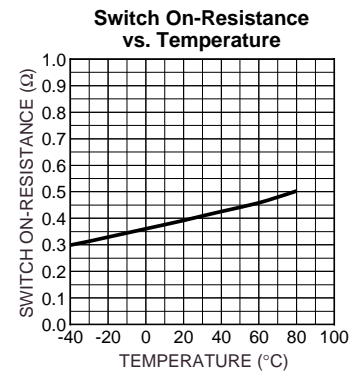
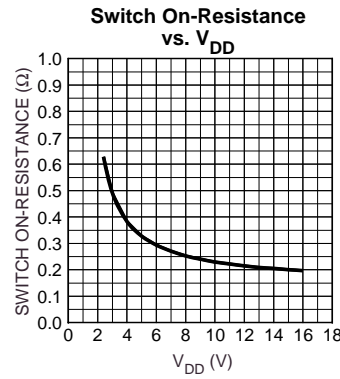
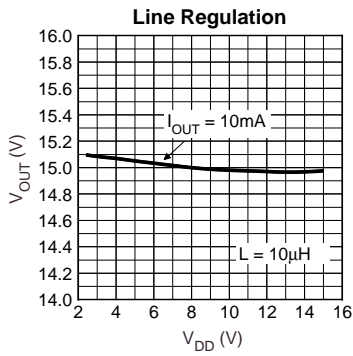
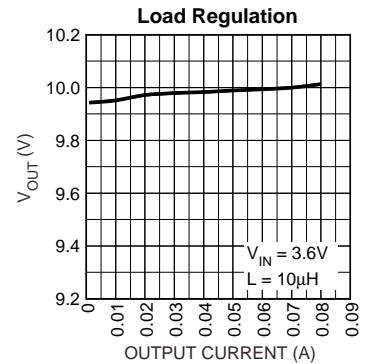
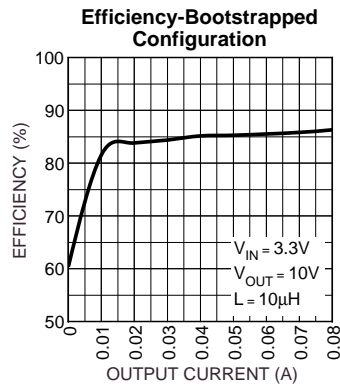
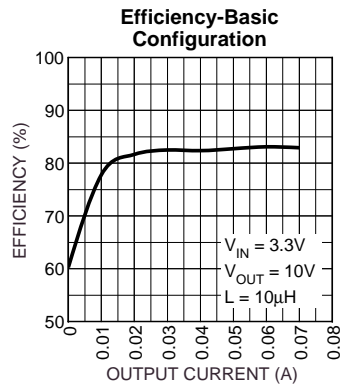

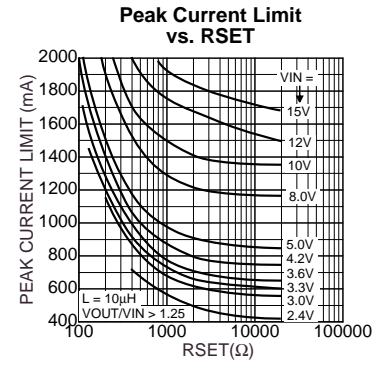
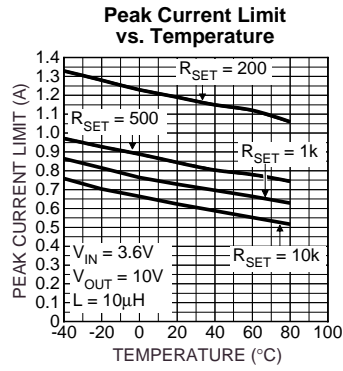
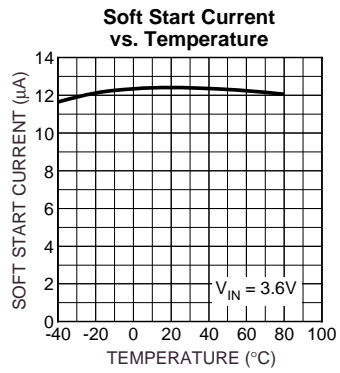

Functional Diagram

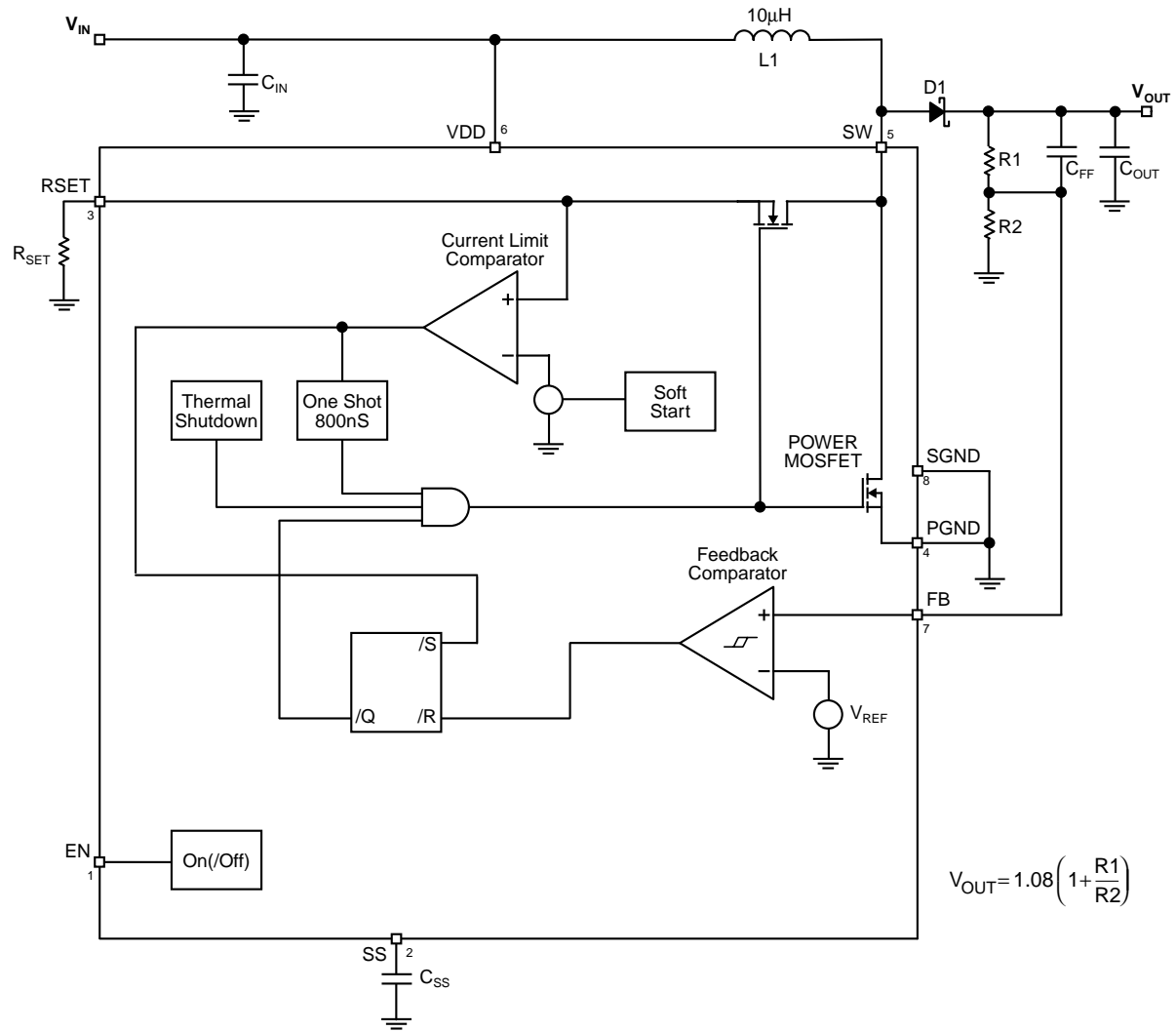

Figure 1. Block Diagram

Functional Description

See “Application Information” for component selection and pre-designed circuits.

Overview

The MIC2145 is a 2.5W boost regulator with programmable peak current limit and a constant off time. Quiescent current for the MIC2145 is typically 200 μ A when the switch is in the off state. Efficiencies above 80% throughout most operating conditions can be realized.

Regulation

Regulation is achieved by both of the comparators, which regulate the inductor current and the output voltage by gating the power MOSFET. Initially, power is applied to the SW and VDD pins. When the part is enabled, the power MOSFET turns on and current flows. When the current exceeds the peak current limit threshold, the current limit comparator fires the one-shot to turn off the power MOSFET for 1000ns and resets the SR flip-flop. The current limit comparator continues to cycle the power MOSFET on and off until the output voltage trips the upper threshold of the feedback comparator, which terminates the cycle. The cycle will begin again when the output voltage drops below the lower hysteresis threshold of the feedback comparator. The feedback comparator has a typical hysteresis of 18mV. Due to the gain of the feedback resistor divider, the voltage at V_{OUT} experiences a typical 167mV of hysteresis for 10V output at 2.4V V_{DD} . This can be reduced by adding a feed-forward capacitor, C_{FF} (See “Output Voltage” section).

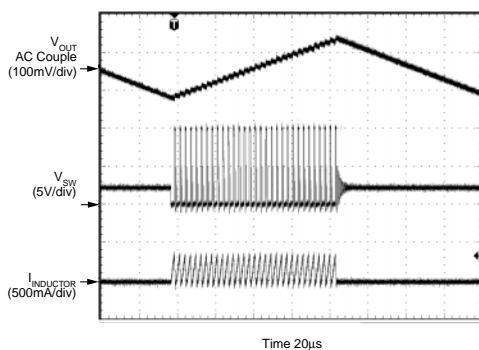

Figure 2. Typical Regulator Waveforms

Output

The maximum output voltage is limited by the voltage capability of the output switch. Output voltages of up to 16V can be achieved with the boost circuit. Higher output voltages require a flyback configuration.

Peak Current Limit

The peak current limit is externally set with a resistor. The peak current range is from 420mA to 2A. There is a minimum resistor value for R_{SET} at lower V_{DD} voltages. For resistor value selections, see the “Typical Characteristics: Peak Current Limit vs. R_{SET} ”.

Soft Start

The MIC2145 has a built in soft start that controls the rise time of the output voltage and the peak current limit threshold during start up.

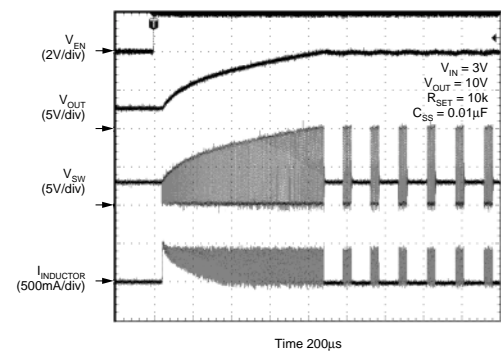

Figure 3. Typical Soft Start Waveforms

Thermal Shutdown

Built-in thermal protection circuitry turns off the power MOSFET when the junction temperature exceeds about 150°C.

Application Information

Pre-designed circuit information is at the end of this section.

Output Voltage

The output voltage of the regulator can be set between 2.4V and 16V by connecting a resistor divider at the FB pin. The resistor values are selected by the following equations:

$$R2 = \frac{1.08V \cdot R1}{V_{OUT} - 1.08V}$$

A value of $1M\Omega$ is recommended for R1 to minimize the quiescent current when the part is off. Then, R2 can be solved using the above equation. A feed-forward capacitor, C_{FF} , ranging from 5pF to 100pF can be used in parallel with R1 to reduce the peak-to-peak output voltage ripple, which is shown in Figures 4 and 5.

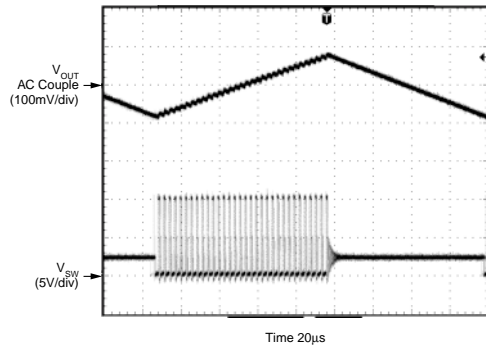

Figure 4. Without Feed-Forward Capacitor

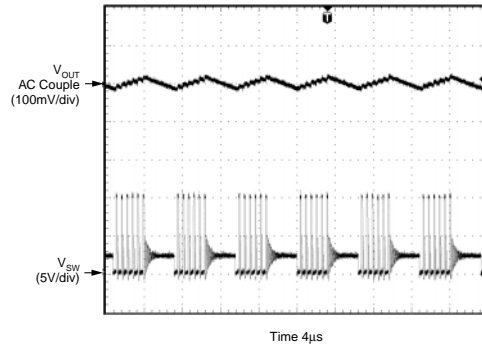

Figure 5. With Feed-Forward Capacitor (100pF)

Bootstrap

A bootstrapped configuration is recommended for applications that require high efficiency at heavy loads (>70mA). This is achieved by connecting the V_{DD} pin to V_{OUT} (see

Figure 7). For applications that require high efficiency at light loads (<70mA), the V_{DD} pin is connected to the input voltage (V_{IN}); this is referred to as the basic configuration (see Figure 6).

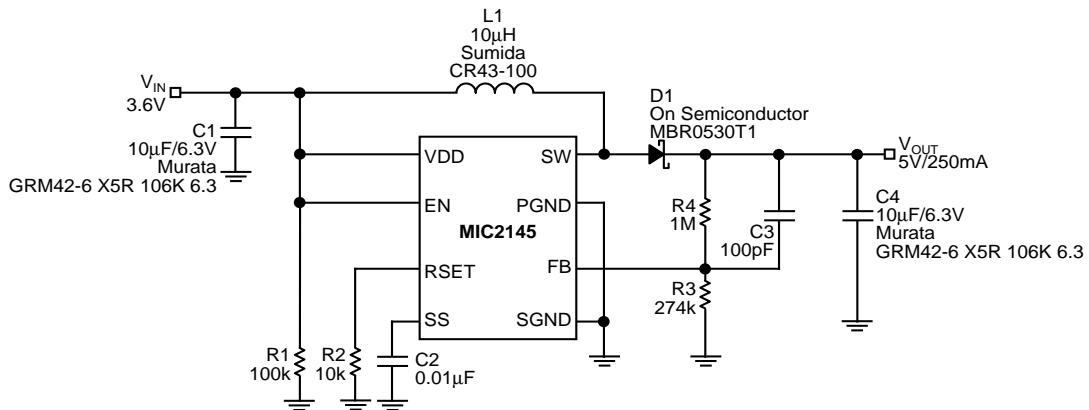

Figure 6. Basic Configuration

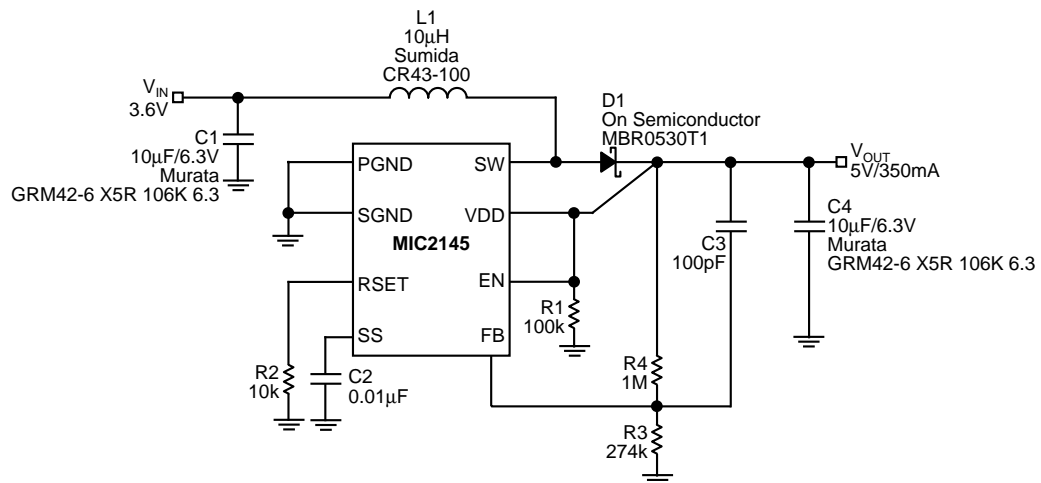

Figure 7. Bootstrap Configuration

Inductor

The MIC2145 has a programmable peak current to allow the usage of small surface mount inductors. A 10 μ H or 4.7 μ H inductor is recommended for most portable applications such as powering white LEDs and biasing LCD panels. The

inductor should have a saturation current rating higher than the peak current during circuit operation. A low ESR (Equivalent Series Resistance) inductor is also desirable for high efficiency. Below are tables that list the maximum output current at minimum input voltage with efficiencies greater than 80%.

$V_{IN(min)}$ (V)	$V_{IN(max)}$ (V)	RSET (Ω)	$I_{OUT(max)}$ (mA)	V_{OUT} (V)
2.4	4.5	10k	80	5
	9.5		25	10
	11.5		20	12
	14.5		15	15
3.0	4.5	10k	150	5
	9.5		50	10
	11.5		40	12
	14.5		30	15
3.6	4.5	10k	250	5
	9.5		70	10
	11.5		50	12
	14.5		40	15
5.0	9.5	10k	190	10
	11.5		130	12
	14.5		90	15

Table 1. Typical Application for 10 μ H Inductor in Basic Configuration

$V_{IN(min)}$ (V)	$V_{IN(max)}$ (V)	RSET (Ω)	$I_{OUT(max)}$ (mA)	V_{OUT} (V)
2.4	4.5	10k	160	5
	9.5		100	10
	11.5		90	12
	14.5		70	15
3.0	4.5	10k	250	5
	9.5		150	10
	11.5		120	12
	14.5		100	15
3.6	4.5	10k	350	5
	9.5		170	10
	11.5		150	12
	14.5		120	15
5.0	9.5	10k	300	10
	11.5		250	12
	14.5		200	15

Table 2. Typical Application for 10 μ H Inductor in Bootstrap Configuration

$V_{IN(min)}$ (V)	$V_{IN(max)}$ (V)	RSET (Ω)	$I_{OUT(max)}$ (mA)	V_{OUT} (V)
3.0	4.5	400	250	5
	9.5		80	10
	9.5		60	12
	9.5		50	15

Table 3. Typical Application for 4.7 μ H Inductor in Basic Configuration

$V_{IN(min)}$ (V)	$V_{IN(max)}$ (V)	RSET (Ω)	$I_{OUT(max)}$ (mA)	V_{OUT} (V)
3.0	4.5	200	500	5
	4.5		225	10
	4.5		150	12
	4.5		130	15

Table 4. Typical Application for 4.7 μ H Inductor in Bootstrap Configuration

Diode

A Schottky diode should be used for the output diode. Most of the application circuits on this data sheet specify the Motorola MBR0530 surface mount Schottky diode. It has a forward current of 0.5A and a low forward voltage drop. For applications that are cost driven, the 1N4148 or equivalent can be used but the efficiency will suffer due to higher forward voltage drop.

Output Capacitor

Low ESR capacitors should be used at the output of the MIC2145 to minimize the switching output ripple voltage. Selection of the capacitor value will depend upon the peak inductor current, inductor size, and the load. MuRata offers the GRM43-2 series with up to 10 μ F at 25V, with a X5R temperature coefficient in a 1812 surface-mount package. For lower output voltage applications, the GRM42-2 (1210 package/10 μ F/16V) and GRM42-6 (1206 package/10 μ F/6.3V) series can be used. Typically, values ranging from 10 μ F to 47 μ F can be used for the output capacitor.

Reducing Peak Current

If lower than 400mA peak current is required then the soft start pin may be shorted to ground. This changes the reference of the current limit comparator. With the soft start pin shorted to ground, the maximum current will approximately reduce to half. The peak current should always be set at least 50% higher than the maximum load current.

Pre-designed Application Circuits

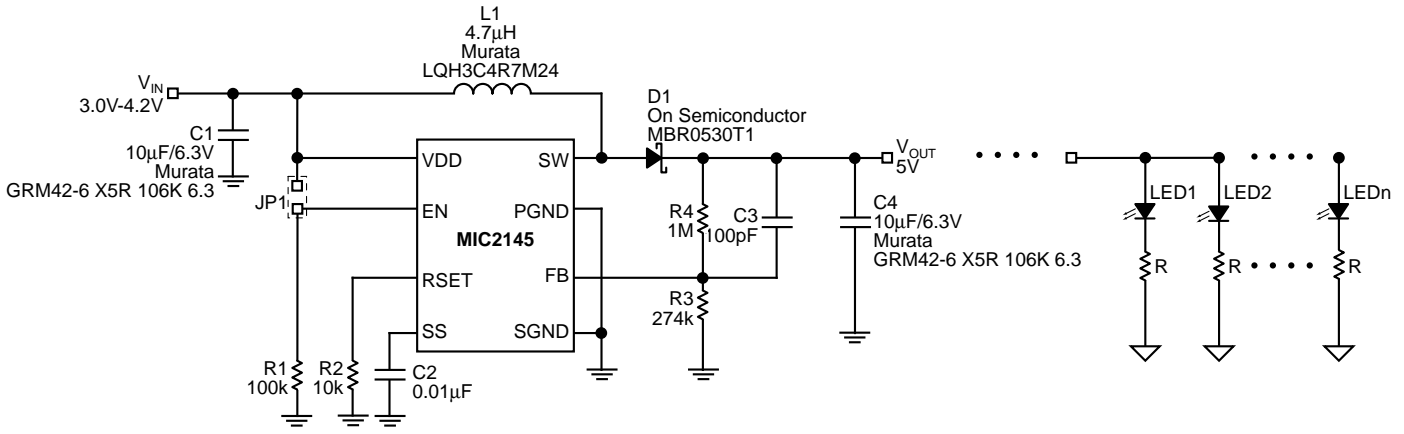

V _{IN}	V _{OUT}	Load	Ripple Voltage	Efficiency
V	V	mA	mV(peak-peak)	%
3.6	5.0	40	<100	85

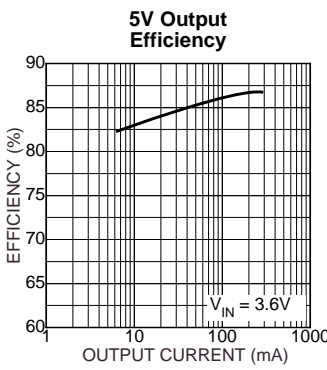
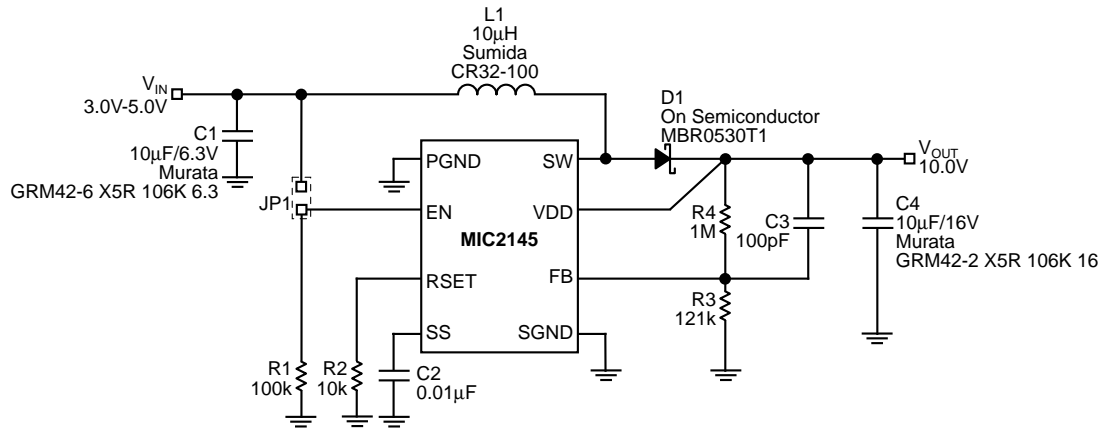

Figure 8. White LED Driver Application (Drives 1 to 10 LEDs in Parallel)



V _{IN}	V _{OUT}	Load	Ripple Voltage	Efficiency
V	V	mA	mV(peak-peak)	%
3.0	10.0	150	<200	83

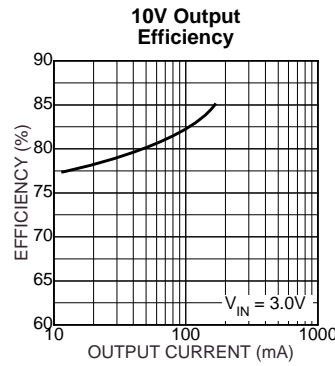
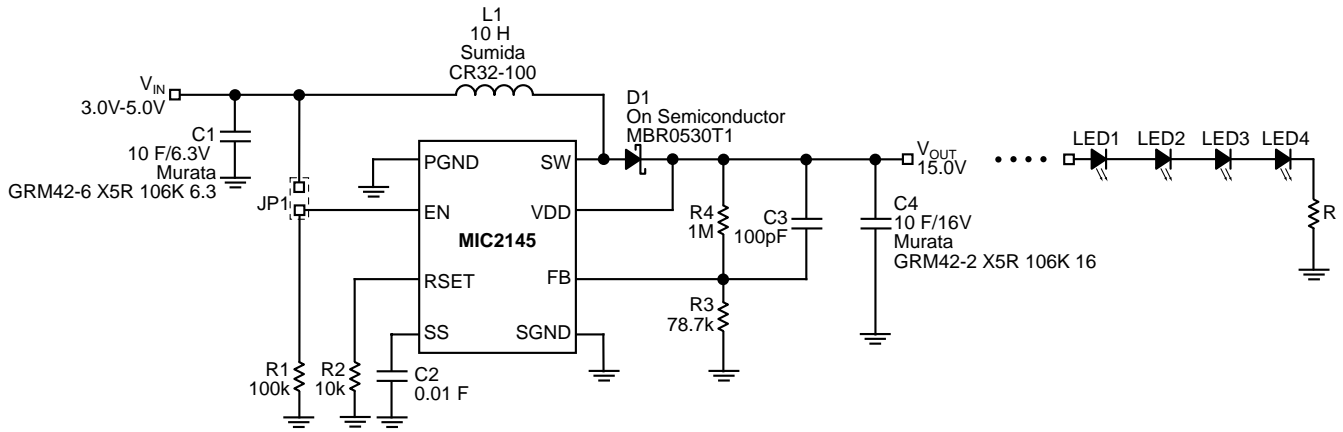

Figure 9. LCD Application — Bootstrap Configuration



V_{IN}	V_{OUT}	Load	Ripple Voltage	Efficiency
V	V	mA	mV(peak-peak)	%
3.6	15.0	40	<100	85

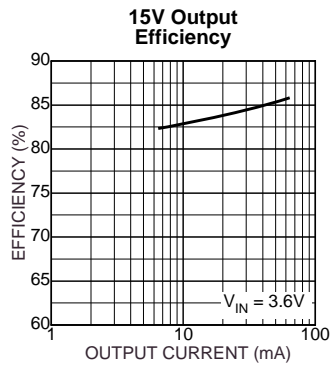
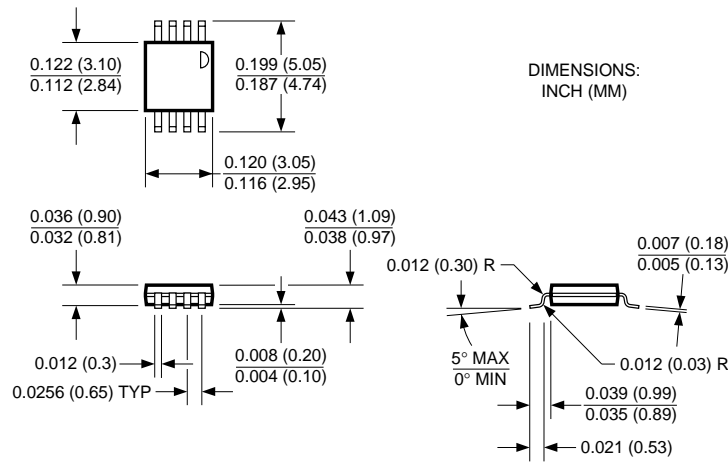
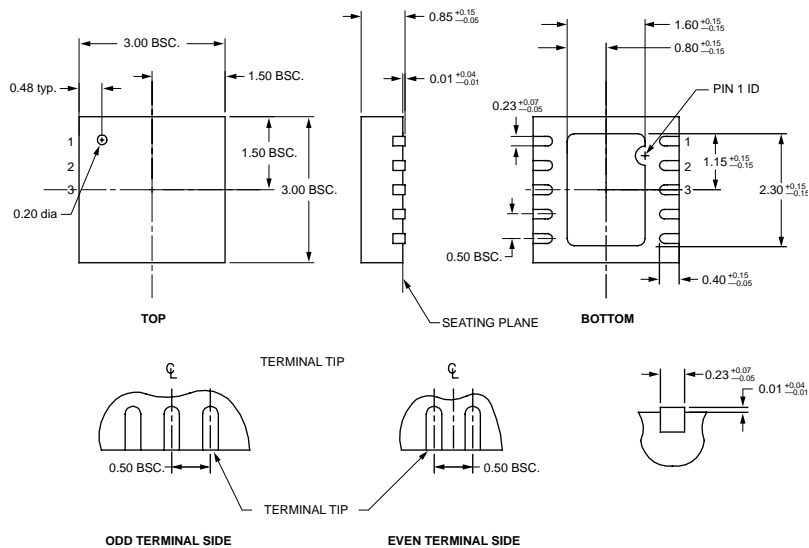

Figure 10. Series White LED Driver Application

Package Information



8-Pin MSOP (MM)



10-Pin MLF (ML)

MICREL, INC. 1849 FORTUNE DRIVE SAN JOSE, CA 95131 USA

TEL + 1 (408) 944-0800 FAX + 1 (408) 944-0970 WEB <http://www.micrel.com>

The information furnished by Micrel in this datasheet is believed to be accurate and reliable. However, no responsibility is assumed by Micrel for its use. Micrel reserves the right to change circuitry and specifications at any time without notification to the customer.

Micrel Products are not designed or authorized for use as components in life support appliances, devices or systems where malfunction of a product can reasonably be expected to result in personal injury. Life support devices or systems are devices or systems that (a) are intended for surgical implant into the body or (b) support or sustain life, and whose failure to perform can be reasonably expected to result in a significant injury to the user. A Purchaser's use or sale of Micrel Products for use in life support appliances, devices or systems is at Purchaser's own risk and Purchaser agrees to fully indemnify Micrel for any damages resulting from such use or sale.