

# T-1 3/4 PACKAGE PIN PHOTODIODE

**MID-54419**

## Description

The MID-54419 is a photo diode mounted in water clear end look plastic package and suitable for the variety wavelength.

## Package Dimensions

Unit: mm ( inches)

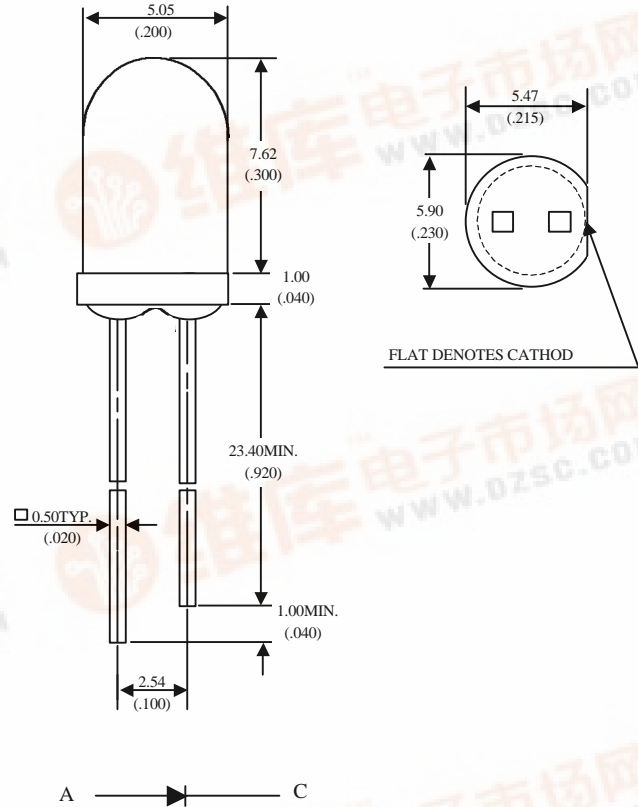

## Features

- High photo sensitivity
- Low junction capacitance
- High cut-off frequency
- Fast switching time
- Acceptance angle: 40°

### Notes :

1. Tolerance is  $\pm 0.25$  mm (.010") unless otherwise noted.
2. Protruded resin under flange is 1.0 mm (.040") max.
3. Lead spacing is measured where the leads emerge from the package.

## Absolute Maximum Ratings

@  $T_A=25^\circ\text{C}$

Parameter	Maximum Rating	Unit
Power Dissipation	150	mW
Operating Temperature Range	-55°C to +100°C	
Storage Temperature Range	-55°C to +100°C	
Lead Soldering Temperature	260°C for 5 seconds	

## Optical-Electrical Characteristics

@ T<sub>A</sub>=25°C

Parameter	Test Conditions	Symbol	Min.	Type .	Max.	Unit
Reverse Breakdown Voltage	I <sub>R</sub> =100μA Ee=0	V <sub>(BR)R</sub>	30			V
Reverse Dark Current	V <sub>R</sub> =10V Ee=0	I <sub>D</sub>			30	nA
Open Circuit Voltage	λ=850nm Ee=0.1mW/cm <sup>2</sup>	V <sub>OC</sub>		350		mV
Rise Time	V <sub>R</sub> =10V λ=850nm	T <sub>r</sub>		40		nsec
Fall Time			T <sub>f</sub>		30	
Light Current	V <sub>R</sub> =5V , λ=850nm Ee=0.1mW/cm <sup>2</sup>	I <sub>L</sub>		12		μA
Total Capacitance	V <sub>R</sub> =3V , f=1MHZ Ee=0	C <sub>T</sub>		25		pF

## Typical Optical-Electrical Characteristic Curves

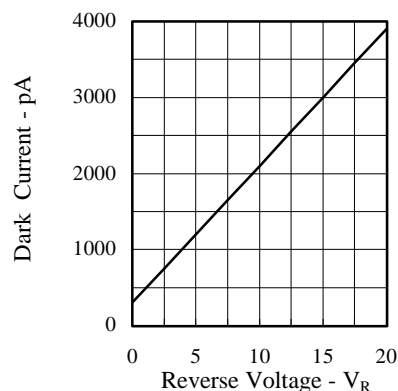

FIG.1 DARK CURRENT VS REVERSE VOLTAGE

T<sub>a</sub> =25°C, Ee=0 mW/cm<sup>2</sup>

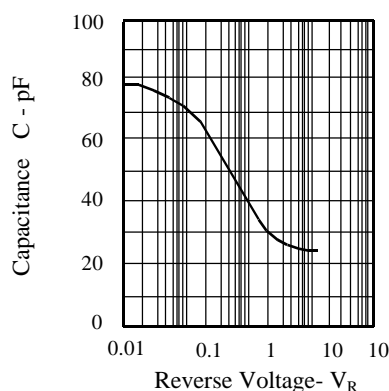

FIG.2 CAPACITANCE VS. REVERSE VOLTAGE

F=1MHZ, Ee=0mW/cm<sup>2</sup>

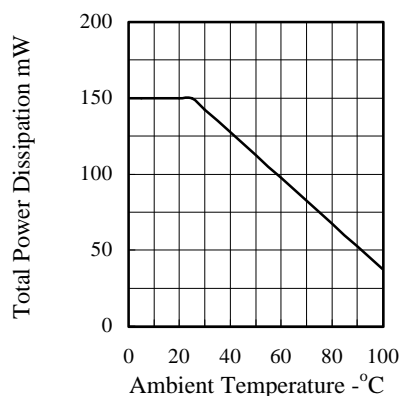

FIG.3 TOTAL POWER DISSIPATION VS. AMBIENT TEMPERATURE

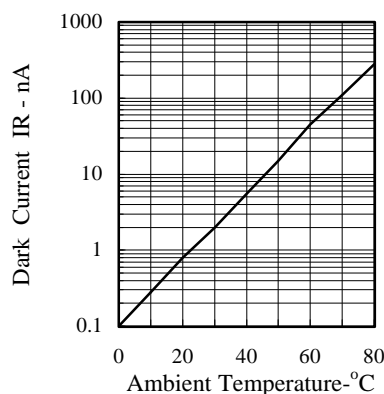

FIG.4 DARK CURRENT VS. AMBIENT TEMPERATURE

V<sub>R</sub>=10, Ee=0 mw/cm<sup>2</sup>

Typical Optical-Electrical Characteristic Curves

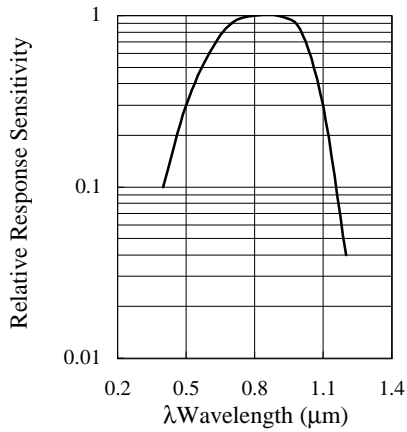

FIG.5 RELATIVE SPECTRAL SENSITIVITY VS. WAVELENGTH

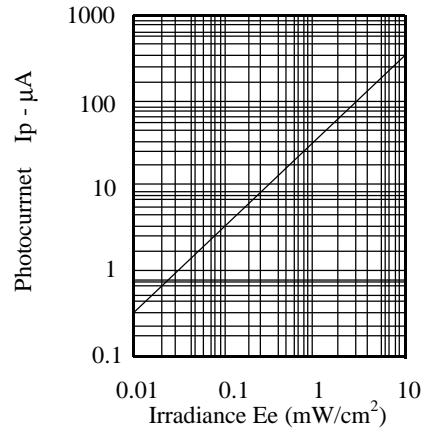

FIG.6 PHOTOCURRENT VS. IRRADIANCE = 850 nm

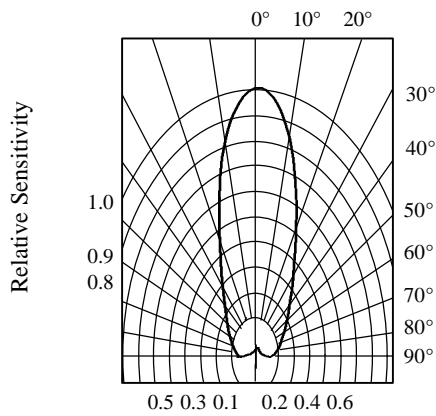

FIG.7 SENSITIVITY DIAGRAM