

GaAlAs T-1 3/4 PACKAGE INFRARED EMITTING DIODE

MIE-554H4

Description

The MIE-554H4 is a GaAlAs infrared LED having a peak wavelength as 850nm. It features ultra-high power, high response speed and molded package with higher radiant intensity. In addition to improving the S/N ratio in applied optical systems, the MIE-554H4 has greatly improved long-distance characteristics as well as significantly increased its range of applicability.

Features

- Ultra-high radiant intensity
- High response speed
- Standard T-1 3/4 (ϕ 5mm) package ,
- Peak wavelength $\lambda_p = 850$ nm
- Radiant angle : 50°

Application

- Data communication
- SIR

Package Dimensions

Unit: mm (inches)

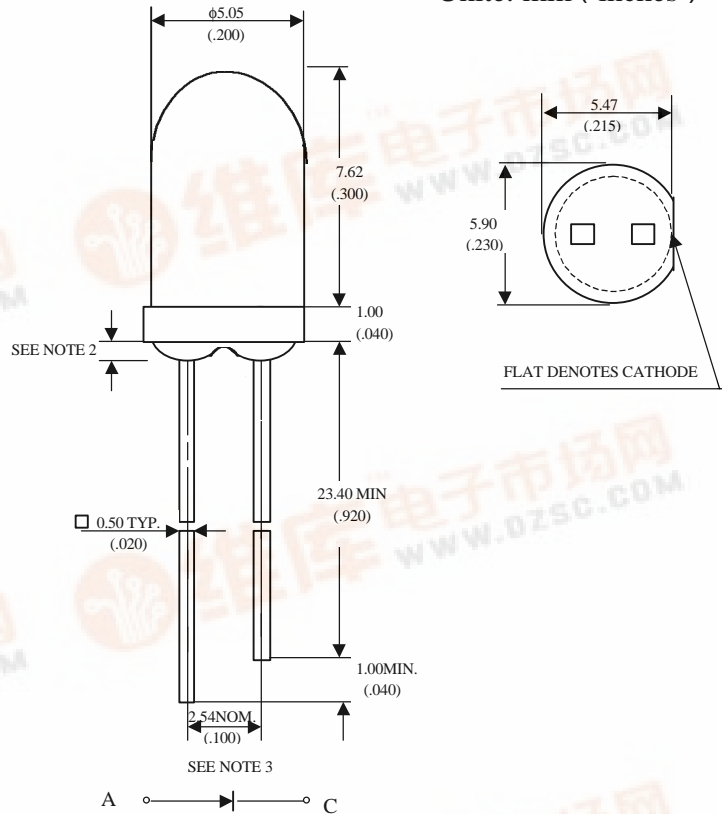

Notes :

1. Tolerance is ± 0.25 mm (.010") unless otherwise noted.
2. Protuded resin under flange is 1.5 mm (.059") max.
3. Lead spacing is measured where the leads emerge from the package.

Absolute Maximum Ratings

'@ $T_A = 25^\circ\text{C}$

Parameter	Maximum Rating	Unit
Power Dissipation	120	mW
Peak Forward Current(300pps,10 μ s pulse)	1	A
Continuos Forward Current	100	mA
Reverse Voltage	5	V
Operating Temperature Range	-55 $^\circ\text{C}$ to +100 $^\circ\text{C}$	
Storage Temperature Range	-55 $^\circ\text{C}$ to +100 $^\circ\text{C}$	
Lead Soldering Temperature	260 $^\circ\text{C}$ for 5 seconds	

Optical-Electrical Characteristics :

@ $T_A=25^{\circ}\text{C}$

Parameter	Test Conditions	Symbol	Min.	Typ .	Max.	Unit
Radiant Intensity	$I_F=20\text{mA}$	I_e		2.1		mW/sr
Forward Voltage	$I_F=50\text{mA}$	V_F		1.5	1.8	V
Reverse Current	$V_R=5\text{V}$	I_R			100	μA
Peak Wavelength	$I_F=20\text{mA}$	λ		850		nm
Spectral Bandwidth	$I_F=20\text{mA}$	$\Delta\lambda$		30		nm
View Angle	$I_F=20\text{mA}$	$2\theta_{1/2}$		50		deg .
Rise Time	$I_F=50\text{mA}$	T_r		20		nsec
Fall Time	$I_F=50\text{mA}$	T_f		30		nsec

Typical Optical-Electrical Characteristic Curves :

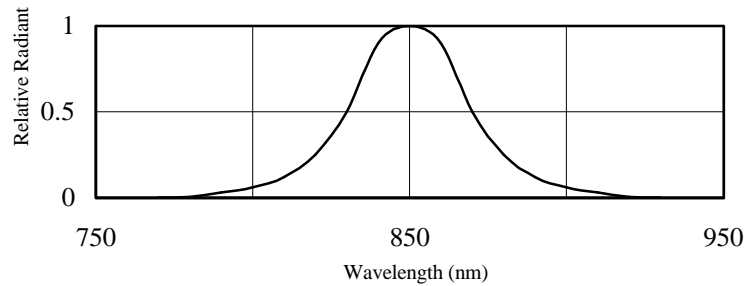

FIG.1 SPECTRAL DISTRIBUTION

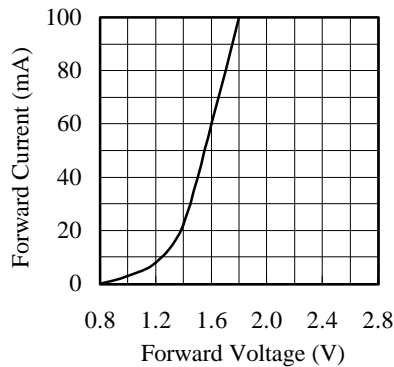

FIG.2 FORWARD CURRENT VS. FORWARD VOLTAGE

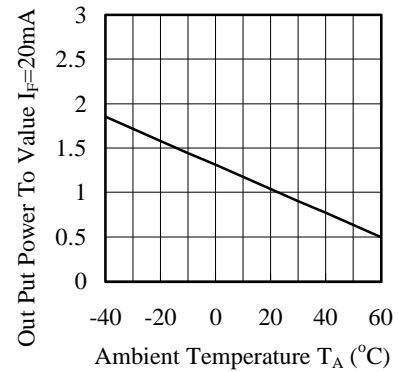

FIG.3 RELATIVE RADIANT INTENSITY VS. AMBIENT TEMPERATURE

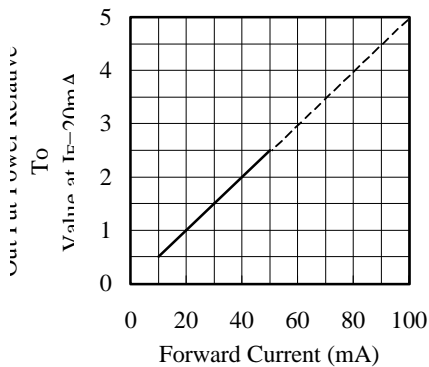

FIG.4 RELATIVE RADIANT INTENSITY VS. FORWARD CURRENT

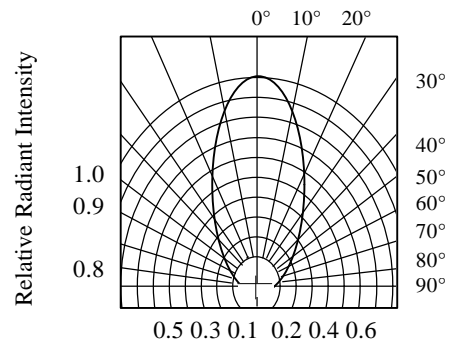

FIG.5 RADIATION DIAGRAM