

MIP713

Silicon MOS IC

■ Features

- Five protective functions (over-current, over-voltage, short-circuit load, over heat, ESD) built-in.
- Heat which goes up when load short-circuits is controlled.
- Although it is a small package, it has resistance of low heat. (When mounted in a substrate.)
- Driving directly from CMOS (microcomputer) is possible.

■ Applications

- For automotive electric equipment

■ Absolute Maximum Ratings

Parameter	Symbol	Rating	Unit
Drain-source voltage	V_{DS}	- 0.5 to +40	V
Output peak current	I_{OP}	3.0	A
Output current	I_O	1.0	A
Input voltage	V_{IN}	- 0.5 to +6.0	V
Input current	I_{IN}	± 2	mA
Drain clamp energy *1	E_{CLP}	17	mJ
Power dissipation 1 *2	P_{D1}	0.2	W
Power dissipation 2 *3	P_{D2}	0.8	W
Channel temperature	T_{ch}	-40 to +150	°C
Storage temperature	T_{stg}	-55 to +150	°C

Note) *1 : L = 10 mH, $I_L = 1.84$ A, $V_{DD} = 20$ V 1 pulse, $T_C = 25^\circ\text{C}$

*2 : Single unit

*3 : Mounting on the PCB (40 mm², Thick 1.7 mm Glass epoxy substrate)

($T_a = 25^\circ\text{C}$)

■ Block Diagram

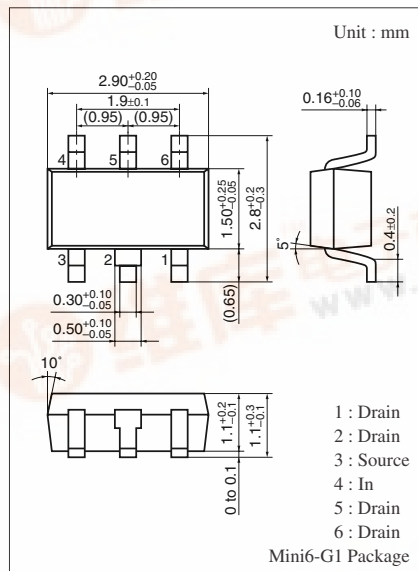
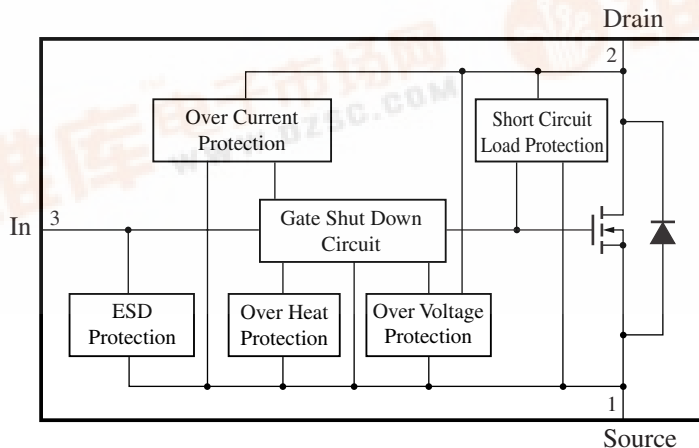

Marking Symbol: MA



■ Electrical Characteristics $T_C = 25^\circ\text{C} \pm 3^\circ\text{C}$

Parameter	Symbol	Conditions	Min	Typ	Max	Unit
Drain-source ON resistance	$R_{DS(on)}$	$V_{IN} = 5\text{ V}, I_{DS} = 1\text{ A}$		0.55	0.8	Ω
Drain-source voltage	$V_{DS(on)}$	$V_{IN} = 5\text{ V}, I_{DS} = 1\text{ A}$		0.55	0.8	V
Drain clamp voltage	$V_{DS(CL P)}$	$V_{IN} = 0\text{ V}, I_{DS} = 3\text{ mA}$	40	52	65	V
Drain-source cutoff current 1	$I_{DS(off)1}$	$V_{IN} = 0\text{ V}, V_{DS} = 12\text{ V}$		27	50	μA
Drain-source cutoff current 2	$I_{DS(off)2}$	$V_{IN} = 0\text{ V}, V_{DS} = 16\text{ V}$		36	68	
Drain-source cutoff current 3	$I_{DS(off)3}$	$V_{IN} = 0\text{ V}, V_{DS} = 30\text{ V}$		79	170	
Input voltage high-level	$V_{IN(H)}$	$I_{DS} = 1\text{ A}$	4			V
Input voltage low-level	$V_{IN(L)}$	$I_{DS} = 1\text{ mA}$			0.8	V
Input current (normal)	$I_{IN(on)}$	$V_{IN} = 5\text{ V}, V_{DS} = 0\text{ V}$		0.2	0.3	mA
Input current (act on protection) *	$I_{IN(PROT)}$	$V_{IN} = 5\text{ V}$		0.6	0.9	mA
Over current protection limit	I_{OCP}	$V_{IN} = 5\text{ V}$	2.0	3.0		A
Short circuit load protection limit	$V_{DS(SHT)}$	$V_{IN} = 5\text{ V}$	2.0	4.0		V
Input voltage of act on protection	$V_{IN(PROT)}$		3.9	6.0		V

- Note) 1. At on-state when drain voltage exceeds the "Short circuit load protection voltage", output current begin to oscillate.
 2. When drain voltage exceeds the "Drain clamp voltage" output MOS turn on, so drain voltage are clamped before the drain-source junction become breakdown.
 3. *: State of short circuit load protection and over heat protection (Designed guarantee).

■ Electrical Characteristics (Reference value: Non guarantee value)

Parameter	Symbol	Conditions	Min	Typ	Max	Unit
Over heat protection temperature	T_{SHD}	$V_{IN} = 5\text{ V}$	150	190		$^\circ\text{C}$
Turn-on time	t_{ON}	$V_{DD} = 30\text{ V}, R_L = 30\ \Omega$		4		μs
Turn-off time	t_{OFF}	$I_{DS} = 1\text{ A}, V_{IN} = 5\text{ V}$		7		

- Note) If the chip temperature exceeds the "Over heat protection temperature", output current is shut down. And if the chip cool down, the protection will operate automatically again.

■ Electrical Characteristics $T_C = -40^\circ\text{C}$ to 125°C

Parameter	Symbol	Conditions	Min	Typ	Max	Unit
Drain-source ON resistance	$R_{DS(on)}$	$V_{IN} = 5\text{ V}, I_{DS} = 1\text{ A}$			1.6	Ω
Drain-source voltage	$V_{DS(on)}$	$V_{IN} = 5\text{ V}, I_{DS} = 1\text{ A}$			1.6	V
Drain clamp voltage	$V_{DS(CL P)}$	$V_{IN} = 0\text{ V}, I_{DS} = 3\text{ mA}$	40		65	V
Drain-source cutoff current 1	$I_{DS(off)1}$	$V_{IN} = 0\text{ V}, V_{DS} = 12\text{ V}$			100	μA
Drain-source cutoff current 2	$I_{DS(off)2}$	$V_{IN} = 0\text{ V}, V_{DS} = 16\text{ V}$			136	
Drain-source cutoff current 3	$I_{DS(off)3}$	$V_{IN} = 0\text{ V}, V_{DS} = 30\text{ V}$			340	
Input voltage high-level	$V_{IN(H)}$	$I_{DS} = 1\text{ A}$	4.3			V
Input voltage low-level	$V_{IN(L)}$	$I_{DS} = 1\text{ mA}$			0.8	V
Input current (normal)	$I_{IN(on)}$	$V_{IN} = 5\text{ V}, V_{DS} = 0\text{ V}$			0.45	mA
Input current (act on protection)	$I_{IN(PROT)}$	$V_{IN} = 5\text{ V}$			1.2	mA
Over current protection limit	I_{OCP}	$V_{IN} = 5\text{ V}$	1.15			A
Short circuit load protection limit	$V_{DS(SHT)}$	$V_{IN} = 5\text{ V}$	1.6			V
Input voltage of act on protection	$V_{IN(PROT)}$		4.0	6.0		V

Request for your special attention and precautions in using the technical information and semiconductors described in this material

- (1) An export permit needs to be obtained from the competent authorities of the Japanese Government if any of the products or technologies described in this material and controlled under the "Foreign Exchange and Foreign Trade Law" is to be exported or taken out of Japan.
- (2) The technical information described in this material is limited to showing representative characteristics and applied circuits examples of the products. It neither warrants non-infringement of intellectual property right or any other rights owned by our company or a third party, nor grants any license.
- (3) We are not liable for the infringement of rights owned by a third party arising out of the use of the product or technologies as described in this material.
- (4) The products described in this material are intended to be used for standard applications or general electronic equipment (such as office equipment, communications equipment, measuring instruments and household appliances).
Consult our sales staff in advance for information on the following applications:
 - Special applications (such as for airplanes, aerospace, automobiles, traffic control equipment, combustion equipment, life support systems and safety devices) in which exceptional quality and reliability are required, or if the failure or malfunction of the products may directly jeopardize life or harm the human body.
 - Any applications other than the standard applications intended.
- (5) The products and product specifications described in this material are subject to change without notice for modification and/or improvement. At the final stage of your design, purchasing, or use of the products, therefore, ask for the most up-to-date Product Standards in advance to make sure that the latest specifications satisfy your requirements.
- (6) When designing your equipment, comply with the guaranteed values, in particular those of maximum rating, the range of operating power supply voltage, and heat radiation characteristics. Otherwise, we will not be liable for any defect which may arise later in your equipment.
Even when the products are used within the guaranteed values, take into the consideration of incidence of break down and failure mode, possible to occur to semiconductor products. Measures on the systems such as redundant design, arresting the spread of fire or preventing glitch are recommended in order to prevent physical injury, fire, social damages, for example, by using the products.
- (7) When using products for which damp-proof packing is required, observe the conditions (including shelf life and amount of time let standing of unsealed items) agreed upon when specification sheets are individually exchanged.
- (8) This material may be not reprinted or reproduced whether wholly or partially, without the prior written permission of Matsushita Electric Industrial Co., Ltd.