

MK1418/MK1420 OPL3, OPL4 + Codec Clock Source

Description

The MK1418 and MK1420 are the ideal way to generate clocks for new sound cards. The MK1420 provides clocks for Analog Devices' AD1848, Crystal Semiconductor's CS4231, and Yamaha's OPL3L, OPL3LS, and OPL4. The MK1420 uses either a 14.318 MHz crystal, or a 14.318 MHz bus clock input to synthesize the clocks required to drive the codec, and the 33.868 MHz required for the FM or wavetable music synthesizer. The chips are ideal for add-in sound cards and motherboards with integrated sound. In an 8 pin SOIC, the MK1420 can save component count, board space, and cost over surface mount crystals, and increase reliability by eliminating three or four mechanical devices from the board.

MicroClock offers many other parts with stereo codec support. The MK1430 has 5 output clocks, the MK1448 has 7, the MK1444 has eight including DSP clocks, and the MK1450/1 offers Pentium™ and SCSI support, plus the stereo codec clocks.

Block Diagram

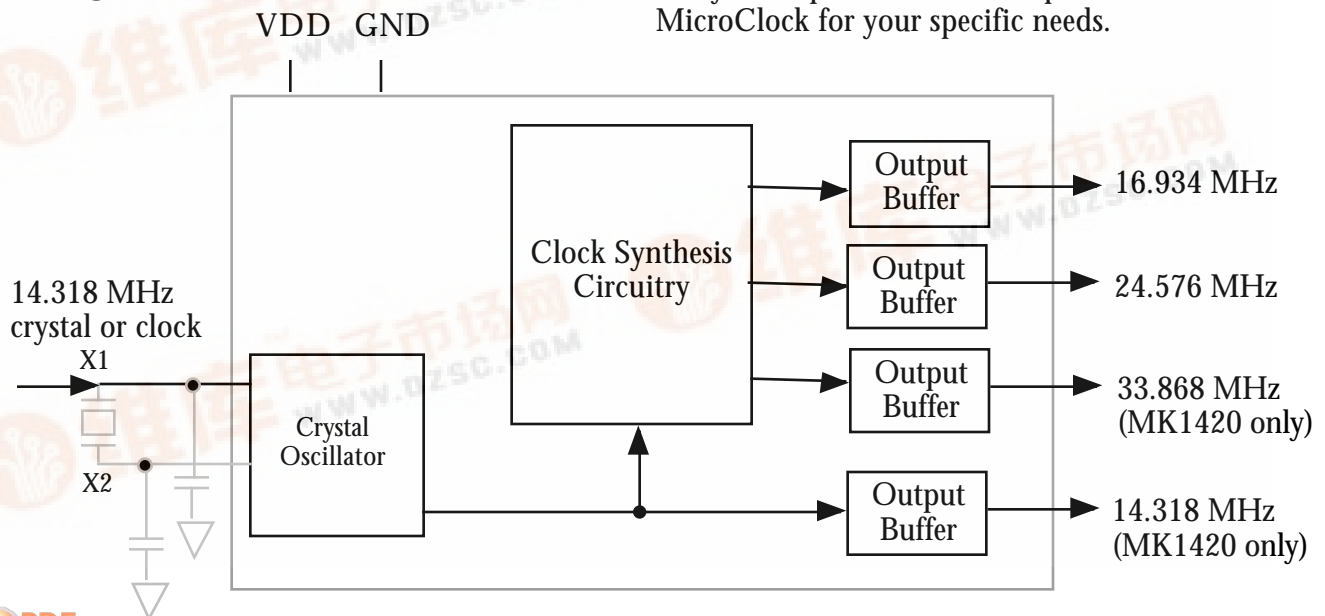

Features

- Packaged in 8 pin SOIC 
- Input crystal or clock frequency of 14.318 MHz
- MK1418 is clock input only
- MK1420 output clock frequencies of 16.934MHz, 24.576 MHz, 33.868 MHz, and 14.318 MHz
- Advanced, low power CMOS process
- Lowest jitter in industry for best audio performance
- Insensitive to input clock duty cycle
- 50% (typ) 14.318 MHz duty cycle with crystal

AC Coupling/Portable Applications

For applications in portable computers, it is possible to drive the input clock with a 3.3V, 14.318MHz clock by a.c. coupling using a 0.01µF capacitor connected in series to the CLKIN pin. But the operating VDD on pin 2 must be 5V±10%. This technique is also effective if the input clock doesn't meet the VIH and VIL specifications on page 3.

Additional Clocks or Features

If more than these four output clocks or features such as power down are needed, MicroClock has many other products in development. Consult MicroClock for your specific needs.

MK1418/MK1420 OPL3, OPL4 + Codec Clock Source

Pin Assignments

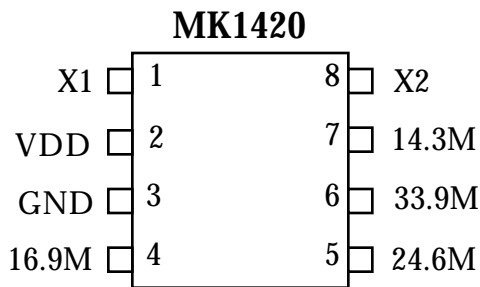
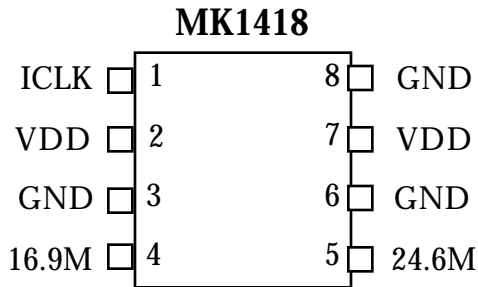

Suggested Layout for MK1420

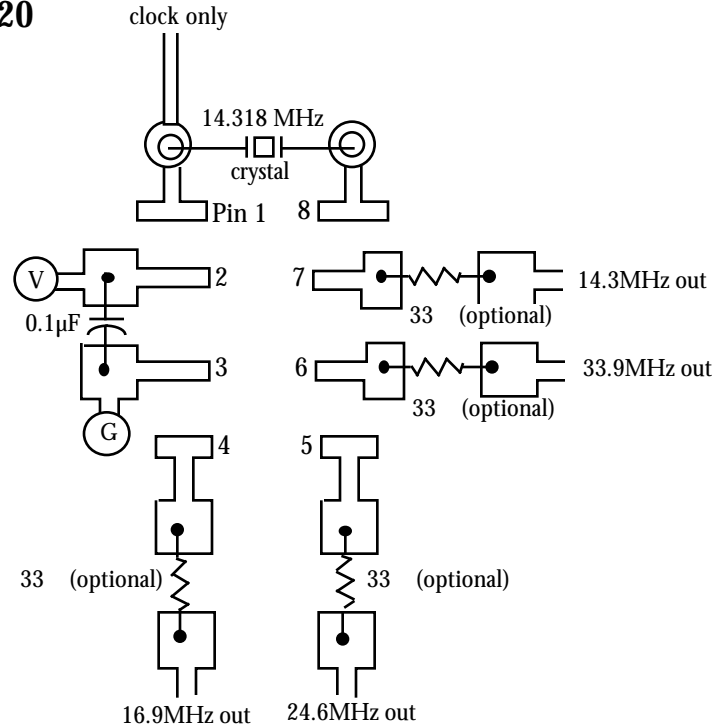

Pin Descriptions for MK1420

Number	Name	Type	Description
1	X1	I	Crystal Connection. Connect to a 14.318 MHz crystal or clock.
2	VDD	P	Connect to +5V.
3	GND	P	Connect to ground.
4	16.9M	O	16.9344 MHz clock output for stereo codec.
5	24.6M	O	24.576 MHz clock output for stereo codec.
6	33.9M	O	33.868 MHz clock output for OPL4.
7	14.3M	O	14.318 MHz clock buffered output for OPL3 or PCMCIA controller.
8	X2	O	Crystal Connection to a 14.318 MHz crystal, or leave unconnected for clock input.

Key: I = Input, O = output, P = power supply connection

External Components/Crystal Selection

A minimum number of external components are required for proper oscillation. For a crystal input, one 22pF load capacitor should be connected to each of the X1 and X2 pins and ground, and a parallel resonant 14.318 MHz, 16pF load, crystal is recommended. Values near these are acceptable, as is a series resonant crystal, but either will result in frequencies which are slightly (up to 0.06%) different from the ideal. For a clock input, connect to X1 and leave X2 unconnected. A decoupling capacitor of 0.1μF should be connected between VDD and GND, and 33 terminating resistors may be used on the clock outputs. These terminating resistors are unnecessary for clock traces less than 1" (25mm).

MK1418/MK1420 OPL3, OPL4 + Codec Clock Source

Electrical Specifications

Parameter	Conditions	Minimum	Typical	Maximum	Units
ABSOLUTE MAXIMUM RATINGS (note 1)					
Supply Voltage, VDD	Referenced to GND			7	V
Inputs	Referenced to GND	-0.5		VDD+.5V	V
Clock Outputs	Referenced to GND	-0.5		VDD+.5V	V
Ambient Operating Temperature		0		70	°C
Soldering Temperature	Max of 20 seconds			260	°C
Storage temperature		-65		150	°C
DC CHARACTERISTICS (at 5.0V unless otherwise noted)					
Operating Voltage, VDD		4.5		5.5	V
Input High Voltage, VIH		3.5	2.5		V
Input Low Voltage, VIL			2.5	1.5	V
Output High Voltage, VOH	IOH=-4mA	VDD-0.4			V
Output High Voltage, VOH	IOH=-25mA	2.4			V
Output Low Voltage, VOL	IOL=25mA			0.4	V
Operating Supply Current, IDD	No Load		18		mA
Input Capacitance			7		pF
Actual Mean Frequency versus Target	Outputs			±0.2	%
AC CHARACTERISTICS					
Input Clock or Crystal Frequency			14.31818		MHz
Input Clock Duty Cycle, 14.318MHz	Time above 2.5V	20		80	%
Output Clock Rise Time	0.8 to 2.0V			1.5	ns
Output Clock Fall Time	2.0 to 0.8V			1.5	ns
Output Clock Duty Cycle, 24.576MHz	Time above 1.5V	40	45	60	%
Output Clock Duty Cycle, 16.9344 MHz	Time above 1.5V	45	50	55	%
Output Clock Duty Cycle, 33.868MHz	Time above 1.5V	45	50	55	%
Output Clock Duty Cycle, 14.318 MHz, Note 3	Time above 1.5V	45	50	55	%
Absolute Clock Period Jitter, except 14.3	Pins 4, 5, 6 only	-400	200	400	ps
One Sigma Clock Period Jitter, except 14.3	Pins 4, 5, 6 only		60		ps

Notes:

- Stresses beyond those listed under Absolute Maximum Ratings could cause permanent damage to the device. Prolonged exposure to levels above the operating limits but below the Absolute Maximums may affect device reliability.
- Typical values are at 25°C.
- If crystal is used as input with CL = 16pf. If a clock is used as input, the duty cycle of the 14.318MHz output will be the same as the input clock.

MK1418/MK1420 OPL3, OPL4 + Codec Clock Source

Package Outline and Package Dimensions

8 pin SOIC

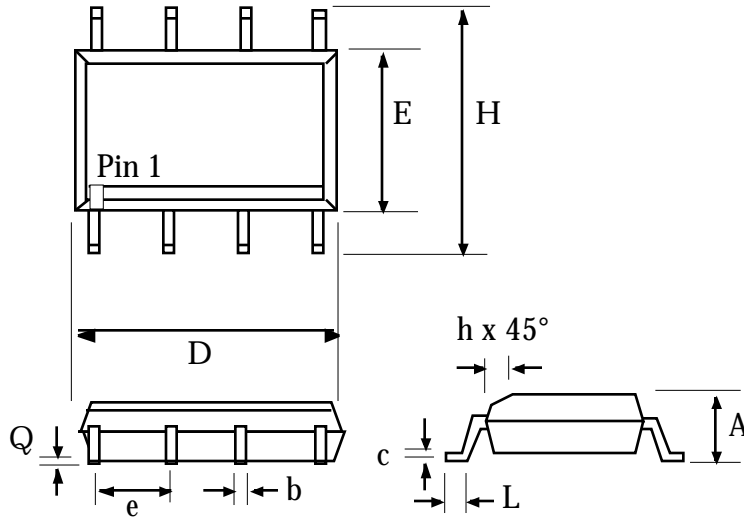

Symbol	Inches		Millimeters	
	Min	Max	Min	Max
A	0.055	0.061	1.397	1.5494
b	0.013	0.019	0.330	0.483
D	0.185	0.200	4.699	5.080
E	0.150	0.160	3.810	4.064
H	0.225	0.245	5.715	6.223
e	.050 BSC		1.27 BSC	
h		0.015		0.381
Q	0.004	0.01	0.102	0.254
L	0.016	0.035	0.406	0.889

Ordering Information

Part/Order Number	Marking	Package	Temperature
MK1418S	MK1418S	8 pin SOIC	0-70°C
MK1418STR	MK1418S	Add tape and reel	0-70°C
MK1420S	MK1420S	8 pin SOIC	0-70°C
MK1420STR	MK1420S	Add tape and reel	0-70°C

While the information presented herein has been checked for both accuracy and reliability, MicroClock Incorporated assumes no responsibility for either its use or for the infringement of any patents or other rights of third parties, which would result from its use. No other circuits, patents, or licenses are implied. This product is intended for use in normal commercial applications. Any other applications such as those requiring extended temperature range, high reliability, or other extraordinary environmental requirements are not recommended without additional processing by MicroClock. MicroClock reserves the right to change any circuitry or specifications without notice. MicroClock does not authorize or warrant any MicroClock product for use in life support devices or critical medical instruments.

1201BO.7