

查询ML12040供应商

捷多邦 专业PCB打样工厂 24小时加急出货

LANSDALE

Semiconductor, Inc.

ML12040

PHASE FREQUENCY DETECTOR

Pin Conversion Table

14 PIN DIP	1	2	3	4	5	6	7	8	9	10	11	12	13	14
20 PIN PLCC	2	3	4	6	8	9	10	12	13	14	16	18	19	20

Inputs		Outputs			
R	V	U	D	\bar{U}	\bar{D}
0	0	X	X	X	X
0	1	X	X	X	X
1	1	X	X	X	X
0	1	X	X	X	X
1	1	1	0	0	1
0	1	1	0	0	1
1	1	1	0	0	1
1	0	1	0	0	1
1	1	0	0	1	1
1	0	0	0	1	1
1	1	0	1	1	0
1	0	0	1	1	0
1	1	0	1	1	0
0	1	0	1	1	0
1	1	0	0	1	1

The ML12040 is a phase-frequency detector intended for use in systems requiring zero phase and frequency difference at lock. In combination with a voltage controlled oscillator, it is useful in a broad range of phase-locked loop applications. Operation of this device is identical to that of Phase Detector #1 of the ML4044.

Operating Frequency = 80 MHz typical

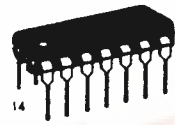

CP suffix
plastic dual in line



-4P
PLCC package

LOGIC DIAGRAM

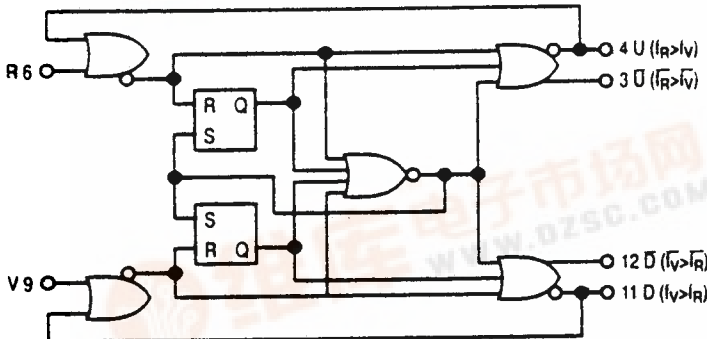

VCC1 = Pin 1
VCC2 = Pin 14
VEE = Pin 7

PIN CONNECTIONS

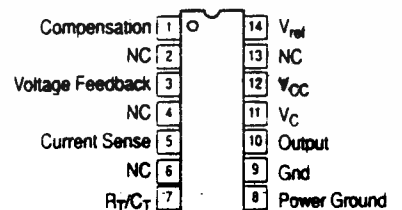

(Top View)

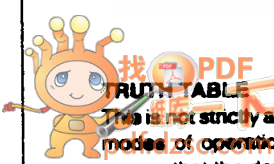

This is not strictly a functional truth table; i.e., it does not cover all possible modes of operation. However, it gives a sufficient number of tests to ensure that the device will function properly in all modes of operation.