

ML4622, ML4624

Fiber Optic Data Quantizer

GENERAL DESCRIPTION

The ML4622 and ML4624 data quantizers are low noise, wideband, bipolar monolithic ICs designed specifically for signal recovery applications in fiberoptic receiver systems. They contain a wideband limiting amplifier which is capable of accepting an input signal as low as $2\text{mV}_{\text{p-p}}$ with a 55dB dynamic range. This high level of sensitivity is achieved by using a DC restoration feedback loop which nulls any offset voltage produced in the limiting amplifier.

The output stage is a high speed comparator circuit with both TTL and ECL outputs. An enable pin is included for added control.

The Link Detect circuit provides a Link Monitor function with a user selectable reference voltage. This circuit monitors the peaks of the input signal and provides a logic level output indicating when the input falls below an acceptable level. This output can be used to disable the quantizer and/or drive an LED, providing a visible link status.

FEATURES

- Data rates up to 40MHz or 80MBd
- Can be powered by either +5V providing TTL or raised ECL level outputs or -5.2V providing ECL levels
- Low noise design: $25\mu\text{V}$ RMS over bandwidth
- Adjustable Link Monitor function with hysteresis
- Wide 55dB input dynamic range
- Low power design
- ML4624 is pin compatible with the ML4621

APPLICATIONS

- IEEE 802.3 10BASE-FL Receiver
- IEEE 802.5 fiber optic token ring, 4 and 16mbps
- Fiber Optic Data Communications and Telecommunications Receivers

ML4622/ML4624 BLOCK DIAGRAM

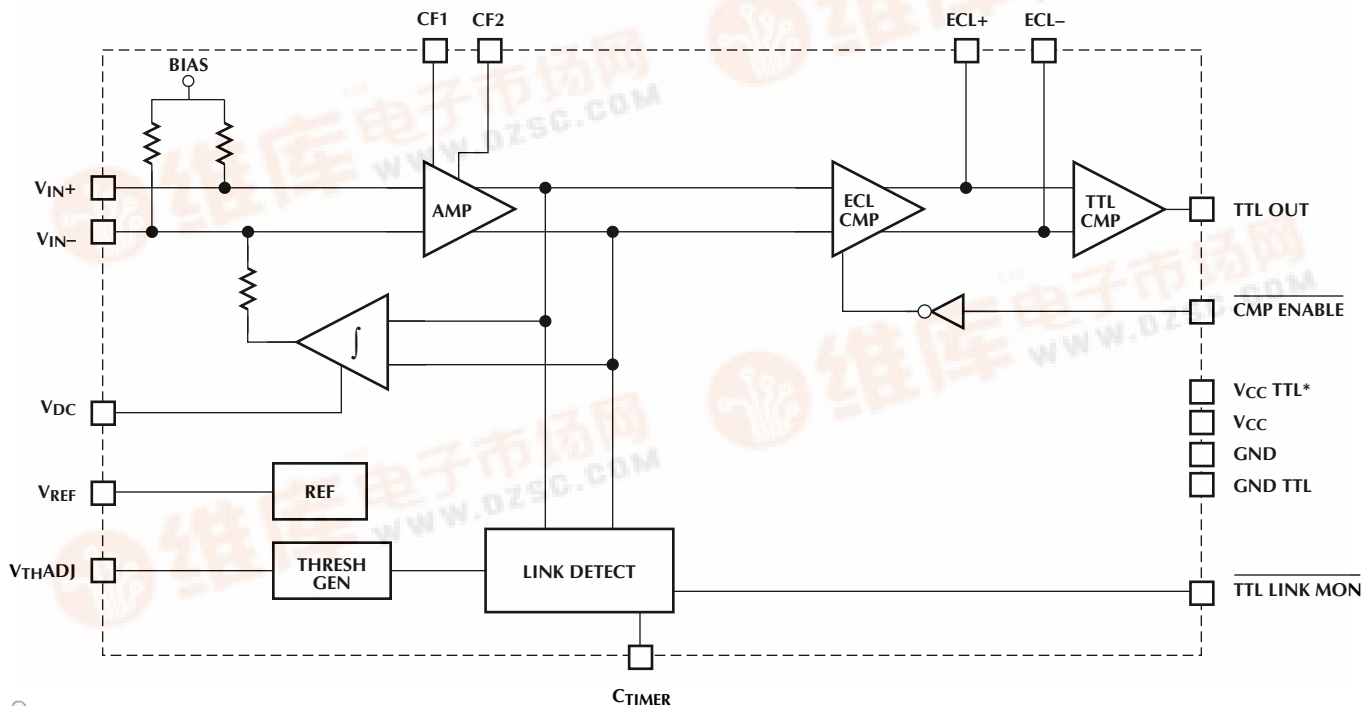

*ML4624 ONLY



ML4622, ML4624

PIN CONNECTIONS

ML4622
16-Pin DIP or
SOIC (Narrow)

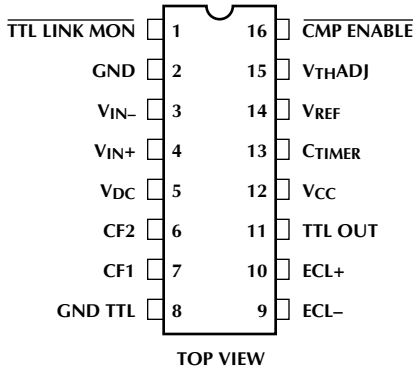

ML4624
24-Pin Narrow DIP

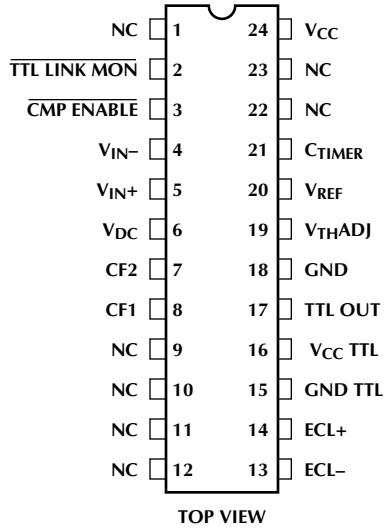

ML4624
28-Pin PCC

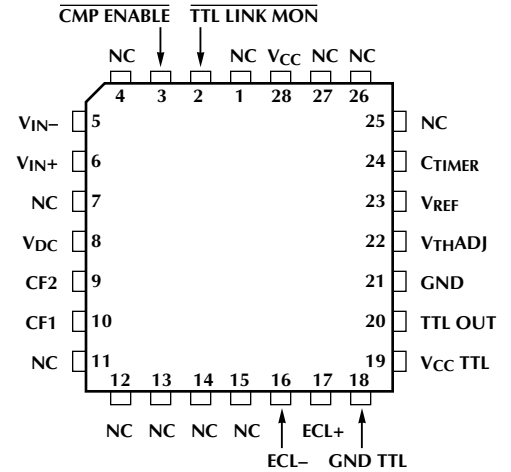

PIN DESCRIPTION

NAME	FUNCTION	NAME	FUNCTION
$\overline{\text{TTL LINK MON}}$	TTL Link Monitor output. Signal is low when the $V_{\text{IN}+}$, $V_{\text{IN}-}$ inputs exceed the minimum threshold, which is set by a voltage on the V_{THADJ} pin. Signal is high when the input signal level is below the threshold. Capable of driving a 10mA LED indicator. This pin can be tied to $\overline{\text{CMP ENABLE}}$.	$V_{\text{CC TTL}}$	The positive supply for the TTL comparator stage. If the TTL output is not necessary, connect $V_{\text{CC TTL}}$ to V_{CC} . (ML4624 only)
$\overline{\text{CMP ENABLE}}$	A low voltage at this TTL input pin enables both the ECL and the TTL outputs. A high TTL voltage disables the comparator output with ECL+ high, ECL- low, and TTL OUT high.	TTL OUT	TTL data output.
$V_{\text{IN}-}$	This input pin should be capacitively coupled to the input source or to filtered ground. (The input resistance is approximately 1.6k Ω .)	V_{DC}	An external capacitor on this pin integrates an error signal which nulls the offset of the input amplifier. If the DC feedback loop is not being used, this pin should be connected to V_{REF} .
$V_{\text{IN}+}$	This input pin should be capacitively coupled to the input source or to filtered ground. (The input resistance is approximately 1.6k Ω .)	CF2	A capacitor from this pin to CF1 controls the maximum bandwidth of the amplifier.
ECL-	The ECL comparator negative output. Has internal pull down resistor. External pull downs are not required unless driving a large capacitive load.	CF1	Connect to CF2 through a capacitor.
ECL+	The ECL comparator positive output. Has internal pull down resistor. External pull downs are not required unless driving a large capacitive load.	GND	Negative supply. Connect to -5.2V for ECL operation, or to ground for TTL or raised ECL operation.
GND TTL	The negative supply for the TTL comparator stage. If the TTL output is not necessary, connect GND TTL to V_{CC} .	V_{THADJ}	This input pin sets the link monitor threshold.
		V_{REF}	A 2.5V reference with respect to GND.
		C_{TIMER}	A capacitor from this pin to V_{CC} determines the Link Monitor response time.
		V_{CC}	Positive supply. Connect to ground for negative ECL operation, or to 5V for TTL or raised ECL operation.

ML4622, ML4624

ABSOLUTE MAXIMUM RATINGS

$V_{CC} - GND$	-0.3 to +7.0
$V_{CC} \text{ TTL} - GND \text{ TTL}$	-0.3 to +7.0
Inputs/Outputs GND	-0.3 to $V_{CC} + 0.3$
Storage Temperature Range	-65°C to +150°C
Lead Temperature (Soldering 10 sec.)	+260°C

ML4622, ML4624 ELECTRICAL CHARACTERISTICS (Note 2 and 3)

Over recommended operating conditions of $T_A = 0^\circ\text{C}$ to 70°C for commercial temperature range, $T_A = -40^\circ\text{C}$ to $+85^\circ\text{C}$ for industrial temperature range, $V_{CC} = 5\text{V} \pm 10\%$, $GND = 0\text{V}$ unless otherwise noted (Note 1).

SYMBOL	PARAMETER	MIN	TYP	MAX	UNITS	CONDITIONS
I_{CC1}	V_{CC} Supply Current (TTL Output Disabled)		35	45	mA	$GND \text{ TTL} = V_{CC}$
I_{CC2}	V_{CC} Supply Current (TTL Output Enabled)		55	70	mA	$GND \text{ TTL} = GND$
V_{REF}	Reference Voltage	2.40	2.50	2.60	V	
I_{VREF}	V_{REF} Output Source Current			5	mA	
A_V	Amplifier Gain		100		V/V	
V_{IN}	Input Signal Range	2		1600	mV _{P-P}	
V_{THADJ} Range	External Voltage at V_{THADJ} to set V_{TH}	0.5		2.6	V	
V_{OS}	Input Offset		3		mV	$V_{DC} = V_{REF}$ (DC loop inactive)
E_N	Input Referred Noise		25		μV	50MHz BW
BW	3dB Bandwidth		45		MHz	
R_{IN}	Input Resistance	1	1.6	2.5	k Ω	V_{IN+}, V_{IN-}
I_{VTHADJ}	Input Bias Current of V_{THADJ}	-200	10	+200	μA	
$t_{PD\text{TTL}}$	Propagation Delay		15		ns	From V_{IN+}, V_{IN-} to TTL Out $V_{IN} = 10\text{mV}_{P-P}$
t_{PDECL}	Propagation Delay		11		ns	From V_{IN+}, V_{IN-} to ECL+, ECL- $V_{IN} = 10\text{mV}_{P-P}$
TTL V_{OH}		2.4			V	$V_{CC} \text{ TTL} = 5\text{V}$, $I_{OH} = -50\mu\text{A}$
TTL V_{OL}				0.55	V	$V_{CC} \text{ TTL} = 5\text{V}$, $I_{OL} = 2\text{mA}$
TTL V_{IH}		2.0			V	
TTL V_{IL}				0.8	V	
TTL I_{IH}		-50		50	μA	$V_{IH} = 2.4\text{V}$
TTL I_{IL}		-1.6		0	mA	$V_{IH} = 0.4\text{V}$

ML4622, ML4624

ML4622, ML4624 ELECTRICAL CHARACTERISTICS (Continued)

Over recommended operating conditions of $T_A = 0^\circ\text{C}$ to 70°C for commercial temperature range, $T_A = -40^\circ\text{C}$ to $+85^\circ\text{C}$ for industrial temperature range, $V_{CC} = 5\text{V} \pm 10\%$, $\text{GND} = 0\text{V}$ unless otherwise noted.

SYMBOL	PARAMETER	MIN	TYP	MAX	UNITS	CONDITIONS
V_{TH}	Input Threshold Voltage ML4622	4	5	6	mV _{P-P}	$V_{THADJ} = V_{REF}$ (note 4)
	ML4624	5	6	7	mV _{P-P}	$V_{THADJ} = V_{REF}$ (note 4)
Hysteresis			20		%	
V_{CM}	Common mode voltage on VIN+, VIN-		1.65		V	
ECL_{VOH}	Output High Voltage at ECL+, ECL-	$V_{CC} - 1.06$		$V_{CC} - 0.7$ $V_{CC} - 0.6$	(note 5)	With 200Ω load tied to $V_{CC} - 2\text{V}$
ECL_{VOL}	Output Low Voltage at ECL+, ECL-	$V_{CC} - 1.89$		$V_{CC} - 1.62$ $V_{CC} - 1.56$	(note 5)	With 200Ω load tied to $V_{CC} - 2\text{V}$

Note 1: Absolute maximum ratings are limits beyond which the life of the integrated circuit may be impaired. All voltages unless otherwise specified are measured with respect to ground.

Note 2: Limits are guaranteed by 100% testing, sampling, or correlation with worst-case test conditions.

Note 3: Low Duty Cycle pulse testing is performed at T_A .

Note 4: DC Tested — Threshold for switching TTL LINK MON from High (off) to Low (on).

Note 5: Industrial temperature range specification..

ML4622, ML4624

FUNCTIONAL DESCRIPTION

AMPLIFIER

The ML4622, ML4624 have an adjustable Bandwidth limiting amplifier. Maximum sensitivity is achieved through the use of a DC restoration feedback loop and AC coupling the input. When AC coupled, the input DC bias voltage is set by an on-chip network at about 1.7V. These coupling capacitors, in conjunction with the input impedance of the amplifier, establish a high pass filter with a 3dB corner frequency, f_L , at

$$f_L = \frac{1}{2\pi 1600C} \quad (1)$$

Since the amplifier has a differential input, two capacitors of equal value are required. If the signal driving the input is single ended, one of the coupling capacitors can be tied to V_{CC} as shown in figure 1.

CF1 and CF2 create a low pass filter with the corner frequency determined by the following equation

$$f_H = \frac{1}{2\pi 800(C + 4pF)} \quad (2)$$

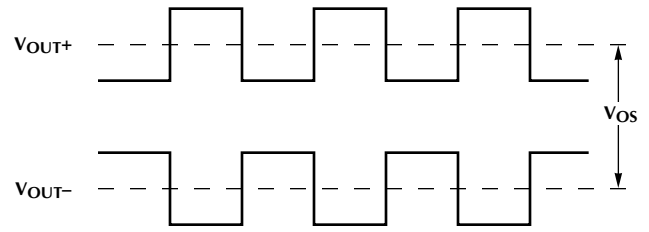
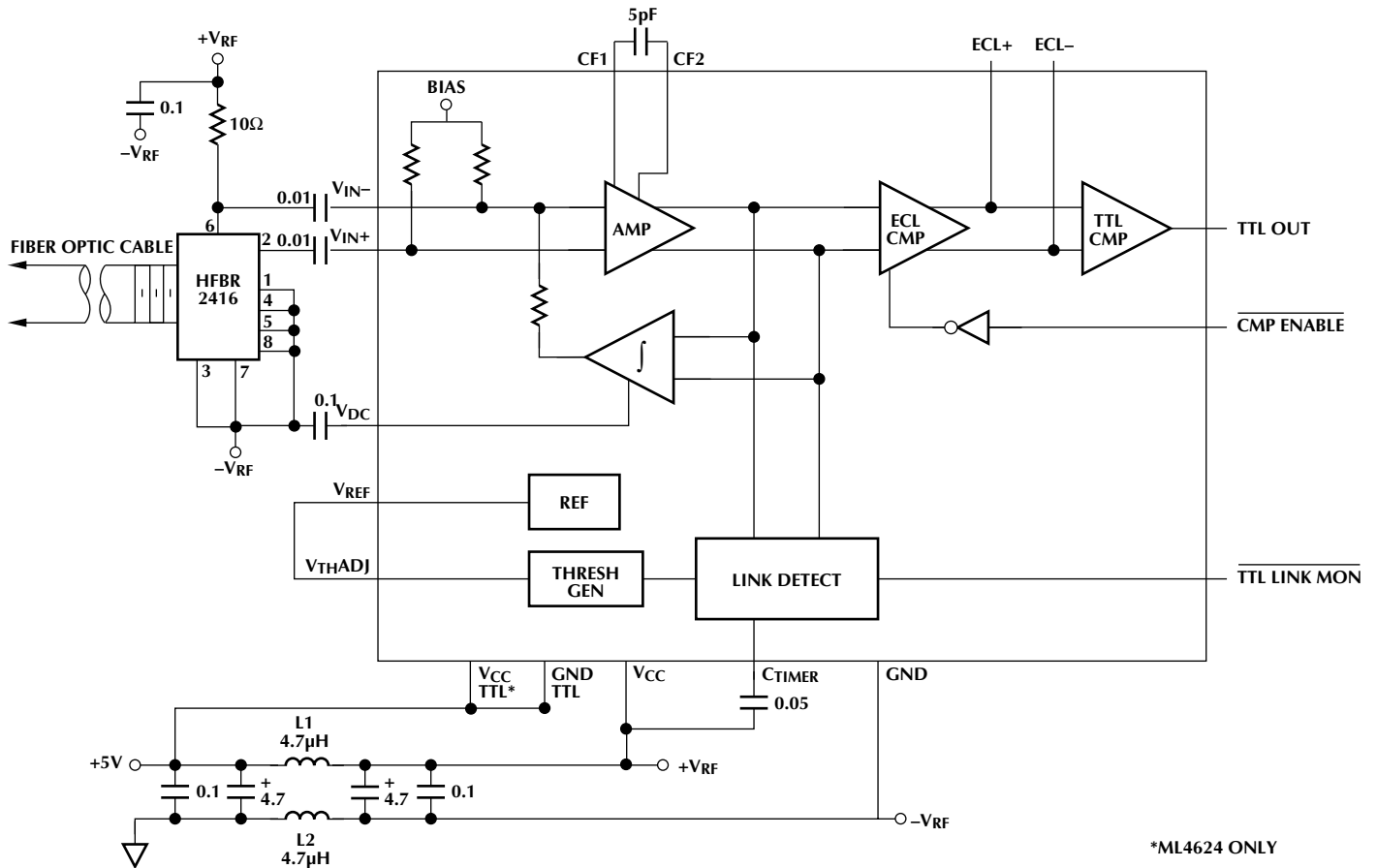

Figure 2.

The above equation applies when a single capacitor is tied between CF1 and CF2. When using two capacitors of equal value (Cap1 from CF1 to V_{CC} , Cap2 from CF2 to V_{CC}) the value derived for C should be doubled.

Although the input is AC coupled, the offset voltage *within* the amplifier will be present at the amplifier's output. This is represented by V_{OS} in figure 2. In order to reduce this error a DC feedback loop is incorporated. This negative feedback loop nulls the offset voltage, forcing V_{OS} to be zero. Although the capacitor on V_{DC} is non-



*ML4624 ONLY

Note: If TTL OUT is used, tie GND TTL to unfiltered ground and remove L1. If TTL OUT and ECL outputs are both used, add 3K pull-down resistors at ECL outputs.

Figure 1. The ML4622, ML4624 Configured for 20MHz Bandwidth

critical, the pole it creates can effect the stability of the feedback loop. To avoid stability problems, the value of this capacitor should be at least 10 times larger than the input coupling capacitors.

COMPARATOR

Two types of comparators are employed in the output section of these Quantizers. The high speed ECL comparator is used to provide the ECL level outputs and in turn drives the TTL comparator. The enable pin, $\overline{\text{CMP ENABLE}}$, is provided to control the ECL comparator. When $\overline{\text{CMP ENABLE}}$ is low the comparators function normally. When it's high, it forces ECL+ high, ECL- low, and TTL OUT high. The $\overline{\text{CMP ENABLE}}$ pin can be controlled with TTL level signals when the Quantizer is powered by 5V and ground.

LINK DETECT CIRCUIT

The Link Detect circuit monitors the input signal and provides a status signal indicating when the input falls below a preset voltage level. When the input falls below the preset voltage level, the $\overline{\text{TTL Link Mon}}$ output changes from active (low) to inactive (high). This signal can be fed to the ML4662 10BASE-FL transceiver or a similar type of function to indicate a Low Light Condition. This output can also be used to disable the output data by tying it to the $\overline{\text{CMP Enable}}$ input.

In many fiber optic systems, including Ethernet and Token Ring, a bit error rate is given at a minimum power level. For example, in a 10Base-FL receiver there must be less than 1×10^{-9} bit errors at a receive power level of -32.5dBm average. Designers of these systems must insure that the bit error rate is lower than the specification at the given minimum power level. One procedure to determine the sensitivity of a receiver is to start at the lowest optical power level and gradually increase the optical power until the BER is met. In this case the Link Detect circuit must not disable the receiver (i.e. $\overline{\text{CMP ENABLE}}$ should be tied to Ground). Once the sensitivity of the receiver is determined, the Link Detector circuit can be set just above the power level that meets the BER specification. This way the receiver will shut off before the BER is exceeded.

The ML4622 and ML4624 quantizers have greater Link Detect sensitivity, noise immunity, and accuracy than their predecessor the ML4621.

The threshold generator shifts the reference voltage at V_{THADJ} through a circuit which has a temperature coefficient matching that of the limiting amplifier. The relationship between the V_{THADJ} and the V_{TH} (the peak to peak input threshold) is:

$$V_{\text{THADJ}} = 417 V_{\text{TH}} \text{ (ML4624)} \quad (3)$$

$$V_{\text{THADJ}} = 500 V_{\text{TH}} \text{ (ML4622)}$$

In most cases, including 10Base-FL, 10Base-FB and Token-Ring, V_{THADJ} can be tied directly to V_{REF} . However if greater sensitivity is required the circuit in figure 3 can be used to adjust the V_{THADJ} voltage. Even if V_{REF} is tied to V_{THADJ} , it is a good idea to layout a board with these two resistors available. This will allow potential future adjustments without board revisions.

The response time of the Link Detect circuit is set by the C_{TIMER} pin. Starting from the link off state (i.e., $\overline{\text{TTL LINK MON}}$ is high), the link can be switched on if the input exceeds the set threshold for a time given by:

$$T = \frac{C_{\text{TIMER}} \times 0.7V}{700\mu A} \quad (4)$$

To switch the link from on to off, the above time will be doubled.

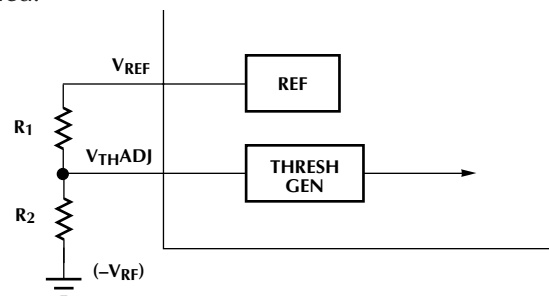

Figure 3.

BURST MODE

In some fiber optic links, the idle signal is DC, or of a frequency that is substantially different from the data. For these links, a faster response time of the DC loop and the Link Monitor is required.

The ML4622 and ML4624 has been designed to accommodate these two requirements. The input coupling capacitors can be relatively small and still maintain stability. With smaller input coupling capacitors and V_{DC} capacitor a faster DC loop response time can be achieved. The Link Monitor is also enhanced to have a faster response time.

ML4622, ML4624

ORDERING INFORMATION

PART NUMBER	TEMPERATURE RANGE	PACKAGE
ML4622CP	0°C to 70°C	Molded DIP (P16)
ML4622CS	0°C to 70°C	Molded SOIC (S16N)
ML4622IS	-40°C to 85°C	Molded SOIC (S16N)
ML4624CP	0°C to 70°C	Molded DIP (P24N)
ML4624CQ	0°C to 70°C	Molded PCC (Q28)

© Micro Linear 1997  **Micro Linear** is a registered trademark of Micro Linear Corporation
Products described herein may be covered by one or more of the following patents: 4,897,611; 4,964,026; 5,027,116; 5,281,862; 5,283,483; 5,418,502; 5,508,570; 5,510,727; 5,523,940; 5,546,017; 5,559,470; 5,565,761; 5,594,376. Other patents are pending.

Micro Linear reserves the right to make changes to any product herein to improve reliability, function or design. Micro Linear does not assume any liability arising out of the application or use of any product described herein, neither does it convey any license under its patent right nor the rights of others. The circuits contained in this data sheet are offered as possible applications only. Micro Linear makes no warranties or representations as to whether the illustrated circuits infringe any intellectual property rights of others, and will accept no responsibility or liability for use of any application herein. The customer is urged to consult with appropriate legal counsel before deciding on a particular application.

2092 Concourse Drive
San Jose, CA 95131
Tel: 408/433-5200
Fax: 408/432-0295