

ML4644*

4 Port AUI Multiplexer

GENERAL DESCRIPTION

The ML4644 AUI Multiplexer contains all the necessary drivers/receivers and control logic to implement a 4 port MAU when used in conjunction with a transceiver chip which has a standard 802.3 AUI interface. Several ML4644s can be cascaded together to implement an 8 or 12 port MAU or standalone device.

Logic within the ML4644 detects collisions resulting from multiple DTEs transmitting simultaneously. In addition, collision signals received from a transceiver attached at the MAU port are propagated to all of the DTE ports. Jabbering DTEs are prevented from loading down the network by an internal jabber timer which disables babbling ports.

FEATURES

- IEEE 802.3 compliant AUI interfaces assure compatibility with any AUI ready devices.
- On-chip Jabber logic, Collision Detection, and SQE test with enable/disable option.
- Selectable SQE Test
- Selectable loopback
- Ten network status LED outputs.

* This Part Is End Of Life As Of August 1, 2000

BLOCK DIAGRAM

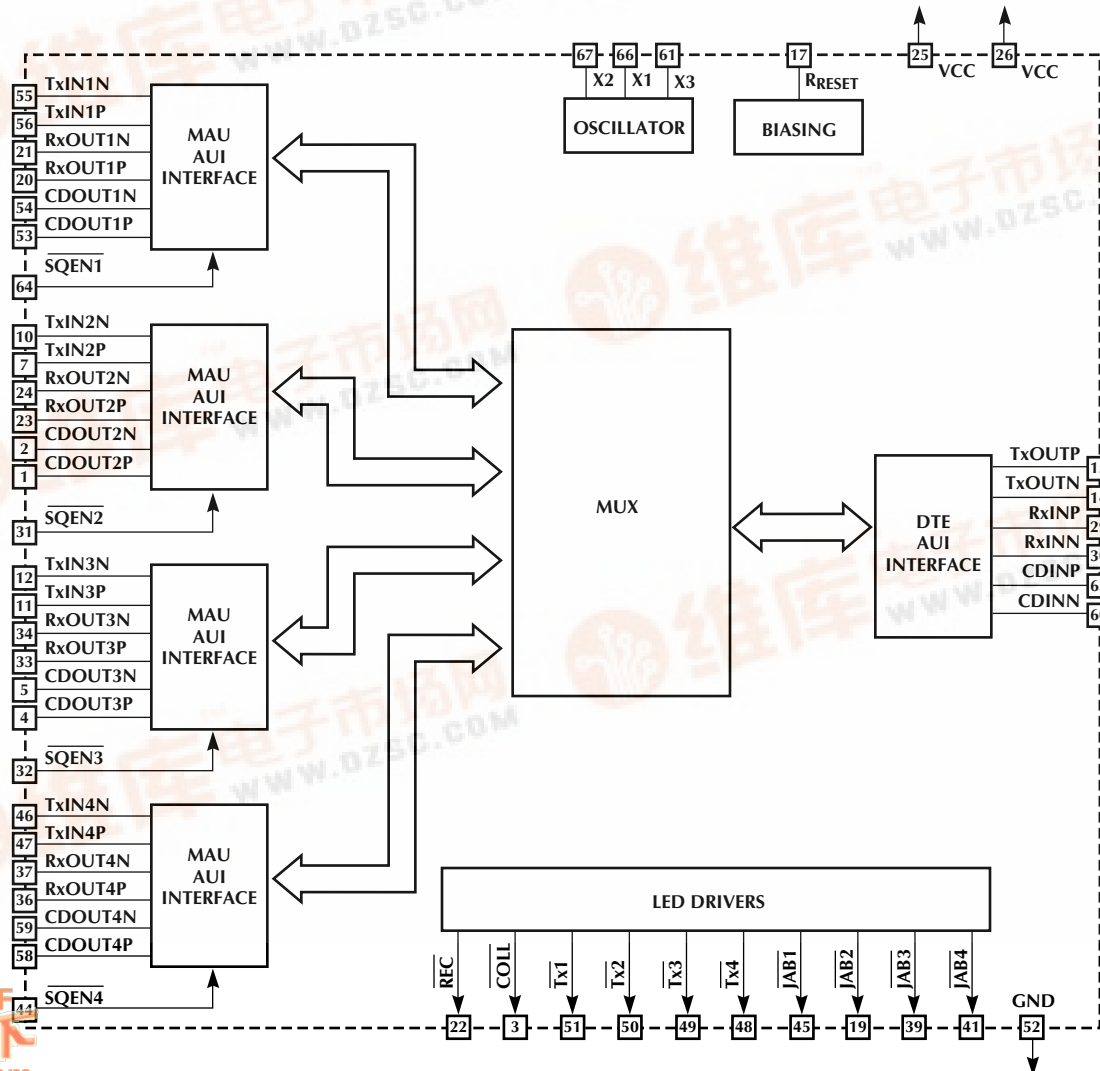

ML4644

PIN CONNECTIONS

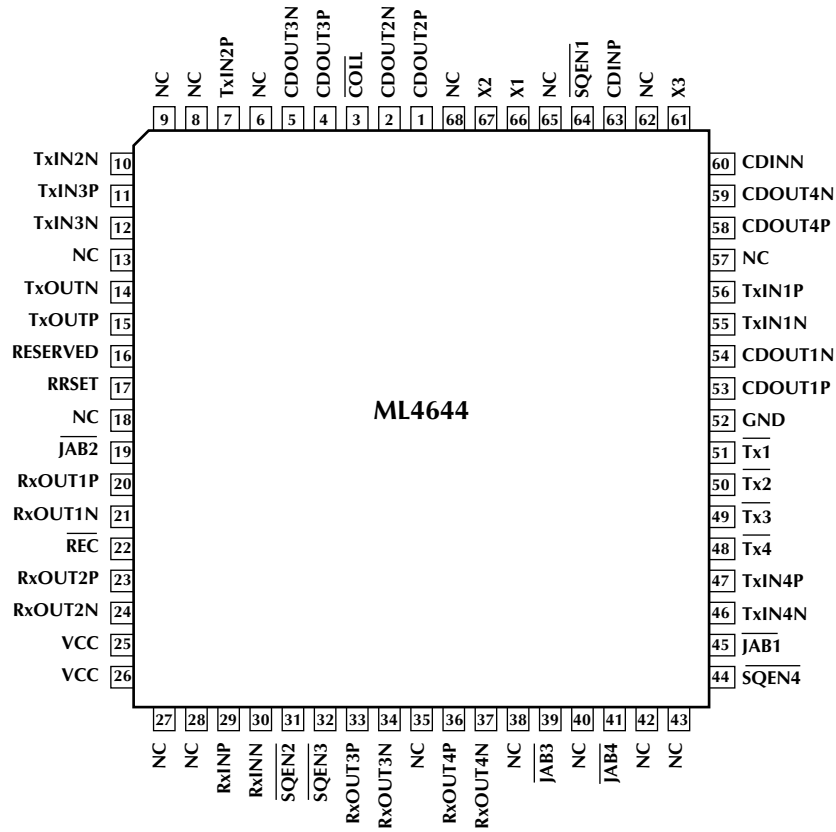

PIN DESCRIPTION

PIN #	NAME	FUNC.	DESCRIPTION	PIN #	NAME	FUNC.	DESCRIPTION
1	CDOOUT2P	Output	Collision signal pair for DTE port 2.	13	NC		No connection.
2	CDOOUT2N	Output	Collision signal pair for DTE port 2.	14	TxOUTN	Output	Transmit signal pair for MAU port.
3	$\overline{\text{COLL}}$	Output	Open collector LED driver for collision.	15	TxOUTP	Output	Transmit signal pair for MAU port.
4	CDOOUT3P	Output	Collision signal pair for DTE port 3.	16	Reserved		This pin should be tied to VCC.
5	CDOOUT3N	Output	Collision signal pair for DTE port 3.	17	RRSET	Input	Bias setting external resistor, 61.9k Ω , connected to VCC
6	NC		No connection.	18	NC		No connection.
7	TxIN2P	Input	Transmit signal pair for DTE port 2.	19	$\overline{\text{JAB2}}$	Output	Open collector jabber LED driver for Jabber of DTE port 2.
8	NC		No connection.	20	RxOUT1P	Output	Receive signal pair for DTE port 1.
9	NC		No connection.	21	RxOUT1N	Output	Receive signal pair for DTE port 1.
10	TxIN2N	Input	Transmit signal pair for DTE port 2.	22	$\overline{\text{REC}}$	Output	Open collector LED driver for receive. Grounding this pin enables loopback.
11	TxIN3P	Input	Transmit signal pair for DTE port 3.				
12	TxIN3N	Input	Transmit signal pair for DTE port 3.				

PIN DESCRIPTION (Continued)

PIN #	NAME	FUNC.	DESCRIPTION	PIN #	NAME	FUNC.	DESCRIPTION
23	RxOUT2P	Output	Receive signal pair for DTE port 2.	48	$\overline{\text{Tx4}}$	Output	Open collector transmit LED driver for Jabber of DTE port 4.
24	RxOUT2N	Output	Receive signal pair for DTE port 2.	49	$\overline{\text{Tx3}}$	Output	Open collector transmit LED driver for Jabber of DTE port 3.
25	VCC	Power	+5V power supply.	50	$\overline{\text{Tx2}}$	Output	Open collector transmit LED driver for Jabber of DTE port 2.
26	VCC	Power	+5V power supply.	51	$\overline{\text{Tx1}}$	Output	Open collector transmit LED driver for Jabber of DTE port 1.
27	NC		No connection.	52	GND	Ground	Ground.
28	NC		No connection.	53	CDOUT1P	Output	Collision signal pair for DTE port 1.
29	RxINP	Input	Receive signal pair for MAU port.	54	CDOUT1N	Output	Collision signal pair for DTE port 1.
30	RxINN	Input	Receive signal pair for MAU port.	55	TxIN1N	Input	Transmit signal pair for DTE port 1.
31	$\overline{\text{SQEN2}}$	Input	Active low. This pin is used to enable the SQE function of DTE port 2.	56	TxIN1P	Input	Transmit signal pair for DTE port 1.
32	$\overline{\text{SQEN3}}$	Input	Active low. This pin is used to enable the SQE function of DTE port 3.	57	NC		No connection.
33	RxOUT3P	Output	Receive signal pair for DTE port 3.	58	CDOUT4P	Output	Collision signal pair for DTE port 4.
34	RxOUT3N	Output	Receive signal pair for DTE port 3.	59	CDOUT4N	Output	Collision signal pair for DTE port 4.
35	NC		No connection.	60	CDINN	Input	Collision signal pair for MAU port.
36	RxOUT4P	Output	Receive signal pair for DTE port 4.	61	X3	Output	ECL output driven by crystal. Can drive X1 inputs on other ML4644S.
37	RxOUT4N	Output	Receive signal pair for DTE port 4.	62	NC		No connection.
38	NC		No connection.	63	CDINP	Input	Collision signal pair for MAU port.
39	$\overline{\text{JAB3}}$	Output	Open collector jabber LED driver for Jabber of DTE port 3.	64	$\overline{\text{SQEN4}}$	Input	Active low. This pin is used to enable the SQE function of DTE port 4.
40	NC		No connection.	65	NC		No connection.
41	$\overline{\text{JAB4}}$	Output	Open collector jabber LED driver for Jabber of DTE port 4.	66	X1	Input	10MHz Crystal input pin. This pin can also be used as a 10MHz clock input pin, or can connect to X3 of another that is driven by a crystal or 10MHz clock.
42	NC		No connection.	67	X2	Input	10 MHz Crystal input pin.
43	NC		No connection.	68	NC		No connection.
44	$\overline{\text{SQEN4}}$	Input	Active low. This pin is used to enable the SQE function of DTE port 4.				
45	$\overline{\text{JAB1}}$	Output	Open collector jabber LED driver for Jabber of DTE port 1.				
46	TxIN4N	Input	Transmit signal pair for DTE port 4.				
47	TxIN4P	Input	Transmit signal pair for DTE port 4.				

ML4644

ABSOLUTE MAXIMUM RATINGS

Absolute maximum ratings are limits beyond which the life of the integrated circuit may be impaired. All voltages unless otherwise specified are measured with respect to ground.

Power Supply Voltage Range V_{CC} . . . GND -0.3 to +6.0V
Input Current RRSET, All LED Driver Pins 60mA
Junction Temperature 150°C
Storage Temperature -65°C to 150°C
Lead Temperature (Soldering 10 seconds) 260°C
Thermal Resistance (θ_{JA}) 44°C/W

OPERATING CONDITIONS

Supply Voltage (V_{CC}) 5V \pm 10%
RRSET 61.9k Ω \pm 1%

ELECTRICAL CHARACTERISTICS

Unless otherwise specified $T_A = 0^\circ\text{C}$ to 70°C , $V_{CC} = 5\text{V} \pm 10\%$. (Notes 1, 2)

PARAMETER	CONDITIONS	MIN	TYP.	MAX	UNITS
Power Supply Current I_{CC} (Note 3)	$V_{CC} = 5\text{V}$	50	150	190	mA
LED Drivers: V_{OL}	$R_L = 510\Omega$ (Note 4)			0.8	V
Transmit Squelch Voltage Level (Tx+, Tx-)		-300	-250	-200	mV
Differential Output Voltage		± 550		± 1200	mV
Common Mode Output Voltage			4.0		V
Differential Output Voltage Imbalance			2	± 40	mV
Loopback Enable	\overline{REC} tied low			0.3	V

Note 1: Limits are guaranteed by 100% testing, sampling, or correlation with worst-case test conditions.
Note 2: Low Duty cycle pulse testing is performed at T_A .
Note 3: This does not include the current from the AUI pull down resistors or the LED output pins.

AC ELECTRICAL CHARACTERISTICS

SYMBOLS	PARAMETER	MIN	TYP.	MAX	UNITS	
TRANSMIT						
t_{XODY}	Transmitter Turn-On Delay		100	200	ns	
t_{TXSDY}	Transmit Steady State Prop. Delay		15		ns	
t_{TXFPW}	Transmit Turn-Off Pulse Width		180		ns	
t_{TXSOI}	Transmit Turn-Off Start of Idle	200	250		ns	
RECEIVE						
t_{RXODY}	Receive Turn-On Delay		100	200	ns	
t_{RXSDY}	Receive Steady State Prop. Delay		15		ns	
t_{RXFPW}	Receive Turn-Off Pulse Width		180		ns	
t_{RXSOI}	Receive Turn-Off Start of Idle	200	250		ns	
t_{AR}	Differential Output Rise Time 20% to 80% ($R_{x\pm}$, COL_{\pm} , $TxOUT_{\pm}$)		3		ns	
t_{AF}	Differential Output Fall Time 20% to 80% ($R_{x\pm}$, COL_{\pm} , $TxOUT_{\pm}$)		3		ns	
COLLISION						
t_{CPSQE}	Collision Present to SQE Assert	0		200	ns	
t_{SQEXR}	Time for SQE to Deactivate After a Collision	0		500	ns	
F_{CLF}	Collision Frequency	XTAL Controlled	8.5	10	11.5	MHz
	Collision Pulse Duty Cycle	XTAL Controlled	40	50	60	%
F_{JAM}	JAM Frequency at $TxOUT_{\pm}$	XTAL Controlled		5		MHz
t_{SQEDY}	SQE Test Delay (Tx Inactive to SQE)	0.6	1.1	1.6	μ s	
t_{SQETD}	SQE Test Duration	0.5	1.0	1.5	μ s	
JABBER, LINK TEST AND LED TIMING						
t_{JAD}	Jabber Activation Delay	7	13.5	20	ms	
t_{JSQE}	Delay from Outputs Disabled to Collision Oscillator On		100		ns	
t_{LEDT}	\overline{REC} , \overline{COLL} , $\overline{Tx1}$, $\overline{Tx2}$, $\overline{Tx3}$, $\overline{Tx4}$ On Time	0.3	1.0	3.0	ms	

TIMING DIAGRAMS

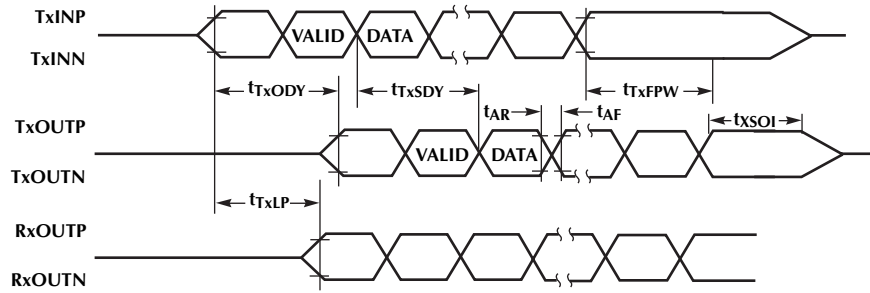

Figure 3. Transmit Timing

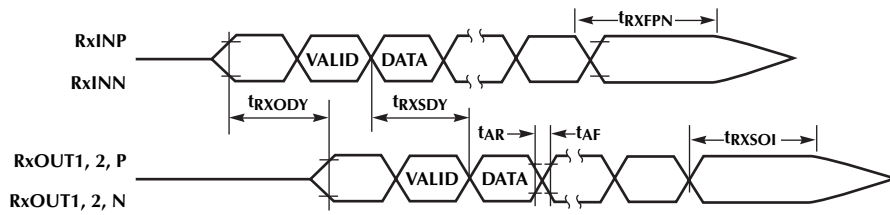

Figure 4. Receive Timing

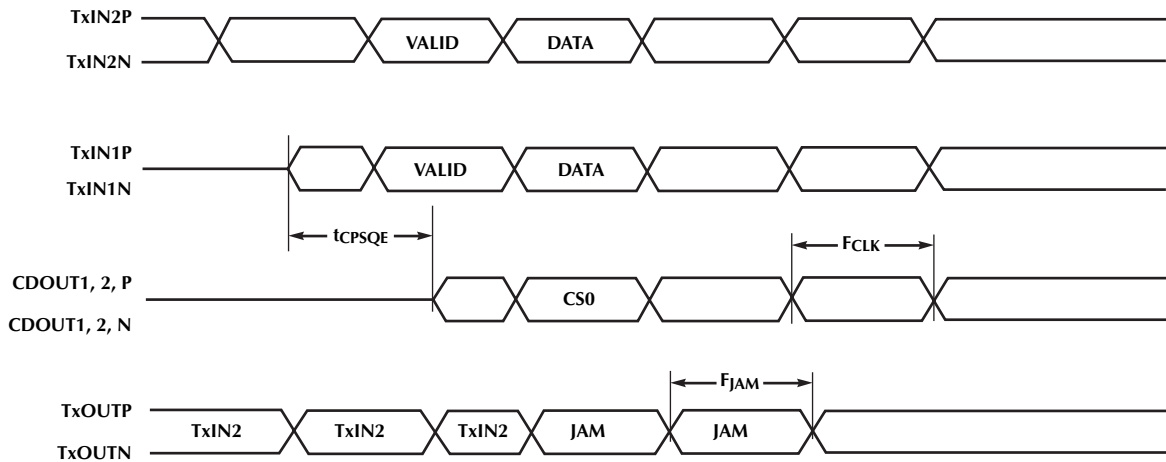

Figure 5. Collision Timing

TIMING DIAGRAMS (Continued)

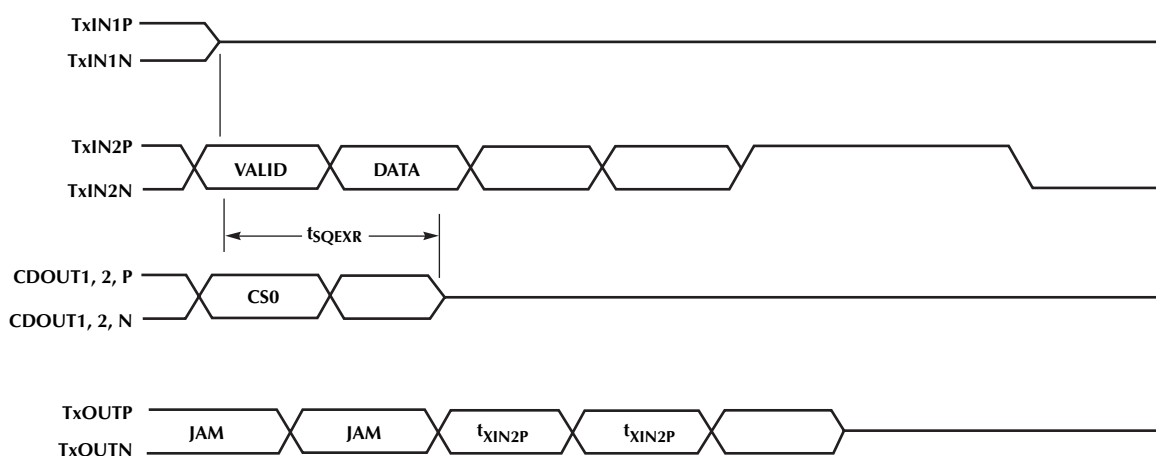

Figure 6. Collision Timing

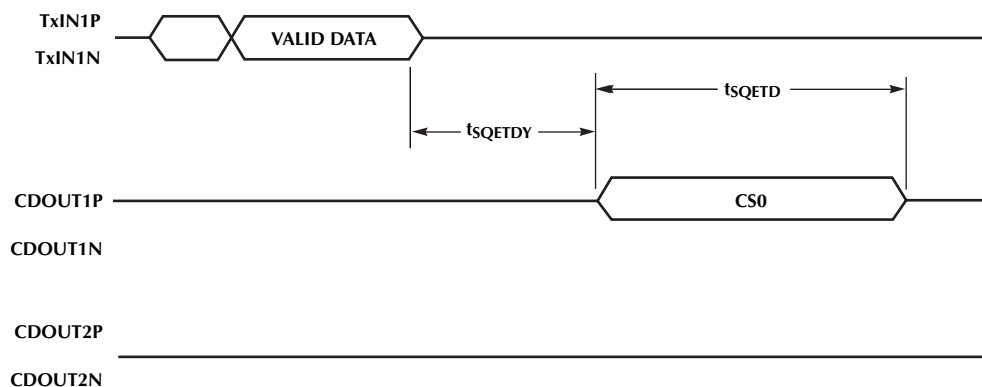

Figure 7. SQE Timing

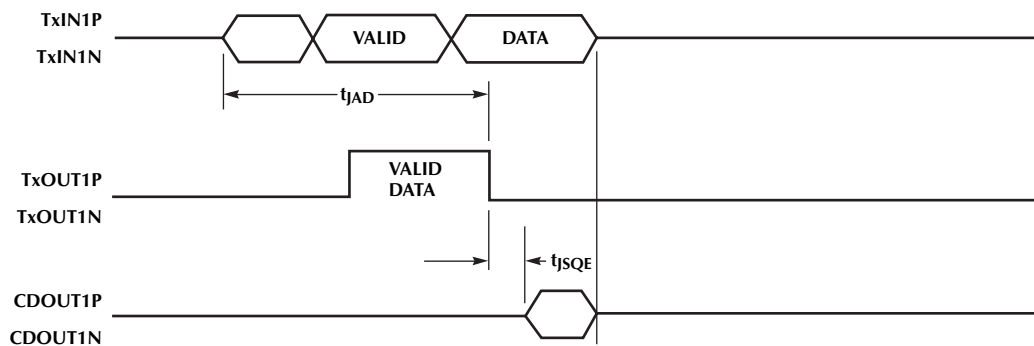

Figure 8. Jabber Timing

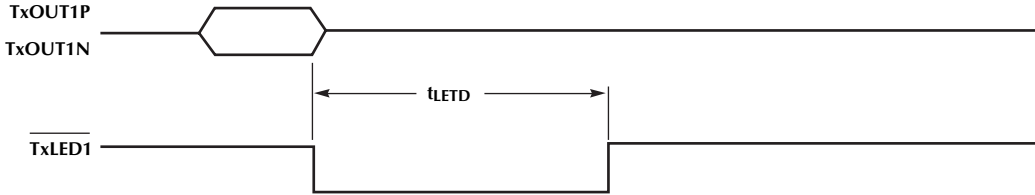

Figure 9. LED Timing

FUNCTIONAL DESCRIPTION

Figure 1 is a block diagram of a Four Port Multiplexer using the ML4644. All AUI interfaces are transformer coupled as required in an AUI connection.

RECEPTION

The receive function consists of detecting data on receive differential data input pair of the MAU port (RxIN) and transmitting this data out of the RxOUT ports of all the DTE port. This data will only be passed onto the DTE port if it meets the unsquelch criteria of the AUI receiver circuit. This provision prevents any noise on the AUI cable from being misinterpreted as data and transmitted to the RxOUT pins.

The receiver squelch circuit rejects signal typically with pulse width less than 20ns or a voltage level more positive than -250mV . Once the receiver is unsquelched, it remains so until reception of the idle signal which is more positive than -170mV for longer than 180ns.

TRANSMISSION

The transmit function consists of detecting data on any of the four differential data input pairs (TxIN1, TxIN2, TxIN3, and TxIN4) and transmitting this data out of the TxOUT pair of the MAU port.

Only data that meets the unsquelch criteria of the AUI receiver circuit will be passed onto the TxOUT port.

LOOPBACK

If the ML4644 is connected to a MAU, or connected to other 4642/44s that are connected to a MAU, the MAU should be used to provide loopback. The loopback function of the MAU will loop data back to the RxIN port which will pass is to all FxOUTs and the $\overline{\text{REC}}$ pin will go low. In some configurations, there will be no MAU, and a ML4644 will be the last chip in the Tx path. In this case, the RxIN port will never be active, since it is not connected, and the $\overline{\text{REC}}$ pin has no function. The $\overline{\text{REC}}$ pin may be grounded and this will put the ML4644 in loopback mode, and data on the TxIN pair will be looped back to all RxOUT ports.

COLLISION

There are two possible collision scenarios.

1. Collision from the network connected to the MAU.
2. Collision between two or more DTEs attached to the multiplexer.

In the case of a network collision, the MAU will send a collision presence signal to the multiplexer. The ML4644 will propagate this signal to the CDOUT pins of each of the DTE ports. The collision signal is a $10\text{MHz} \pm 0.01\%$ signal.

When a collision event occurs between two or more DTE ports, the ML4644 will send the collision presence signal to each of the DTEs via the collision ports. At the same time a 5MHz JAM signal is sent to the network.

SQE TEST FUNCTION

The Signal Quality Error (SQE) test function allows the DTE to determine whether or not the collision port is functional. After each transmission, during the interpacket gap time, the collision signal will be activated on the CDOUT port of the same DTE port data has been transmitted, for typically $1\mu\text{s}$. The SQE function is not activated at the DTE ports that are in jabber state. The SQE function of each port can be disabled by tying the SQEN pin high.

JABBER FUNCTION

The jabber function prevents a malfunction transmitter from continuous transmission and thus loaded down the network. Within the ML4644, there is a jabber timer. The timer starts at the beginning of a received packet and resets at the end of each packet. If the packet lasts longer than 7 to 20ms the jabber circuit will disable the offending TxIN receiver (the transmission of excessively long packet is thus terminated) and generates a collision signal to the collision port of the offending DTE port. The DTE port will exit the jabber state when the transmission goes idle.

LED DRIVERS

The ML4644 has ten LED drivers. Each DTE port has a transmit LED and a jabber LED and the MAU port has a receive LED. Additionally there is a collision LED which indicates the presence of a collision condition. All LED drivers are active low open collector driver.

All LED drivers except the jabber have pulse 1ms pulse stretchers. The pulse stretchers provide adequate on time for the LED to be visible.

CASCADING THE ML4644 FOR EIGHT PORT MULTIPLEXER APPLICATION

An 8 port multiplexer can be realized by using two ML4644s and one ML4642. In this configuration (see fig. 2), the SQE function of the ML4642 should be disabled to prevent false collision signalling. The SQE function in this configuration is performed by each DTE port of the ML4644 independently. Only one crystal is required, since X3 of the ML4644 with the crystal can drive X1 of the other chip.

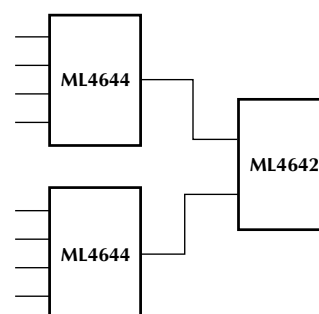

Figure 2. Block Diagram of an Eight port Multiplexer.

ML4644

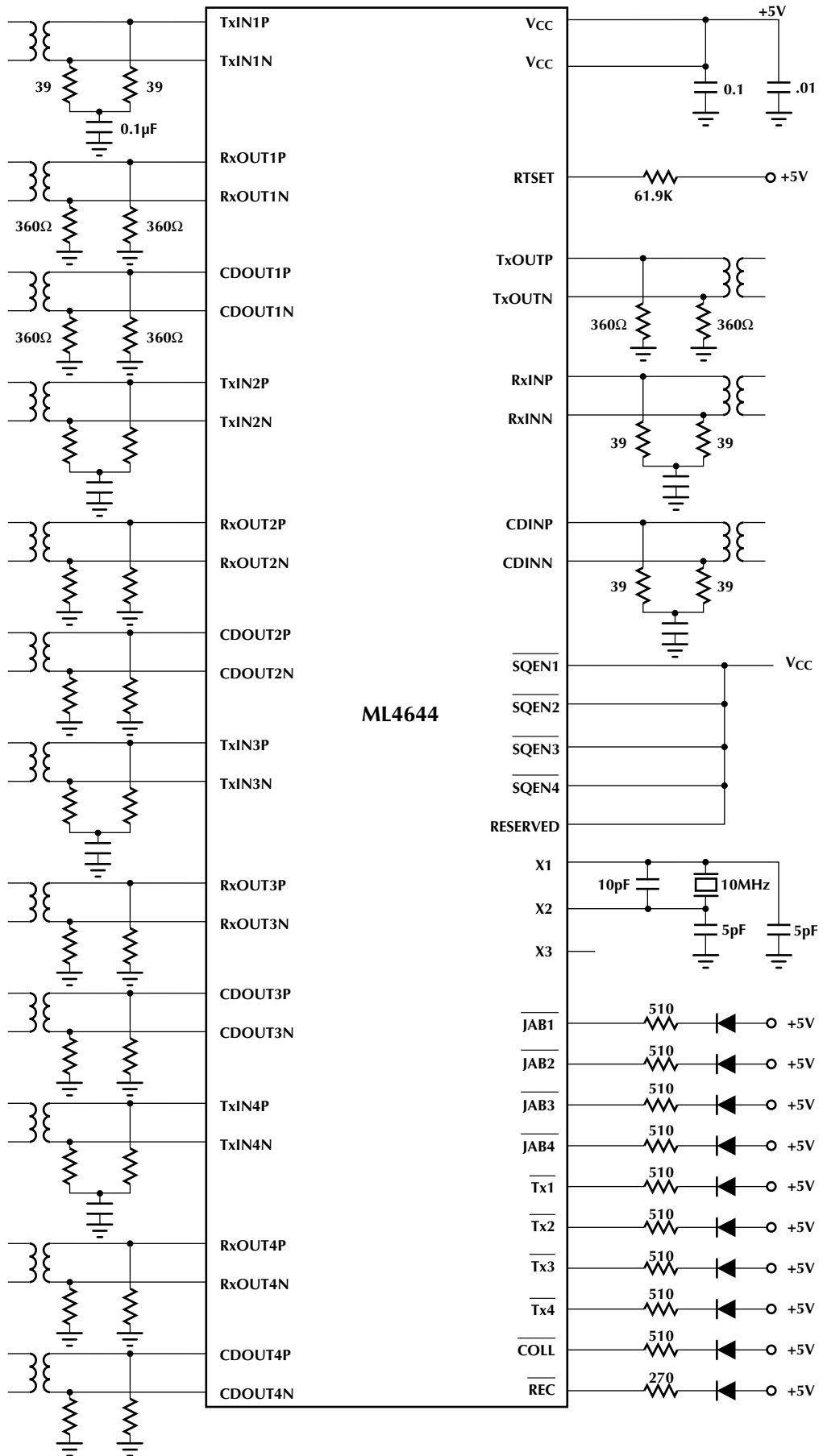
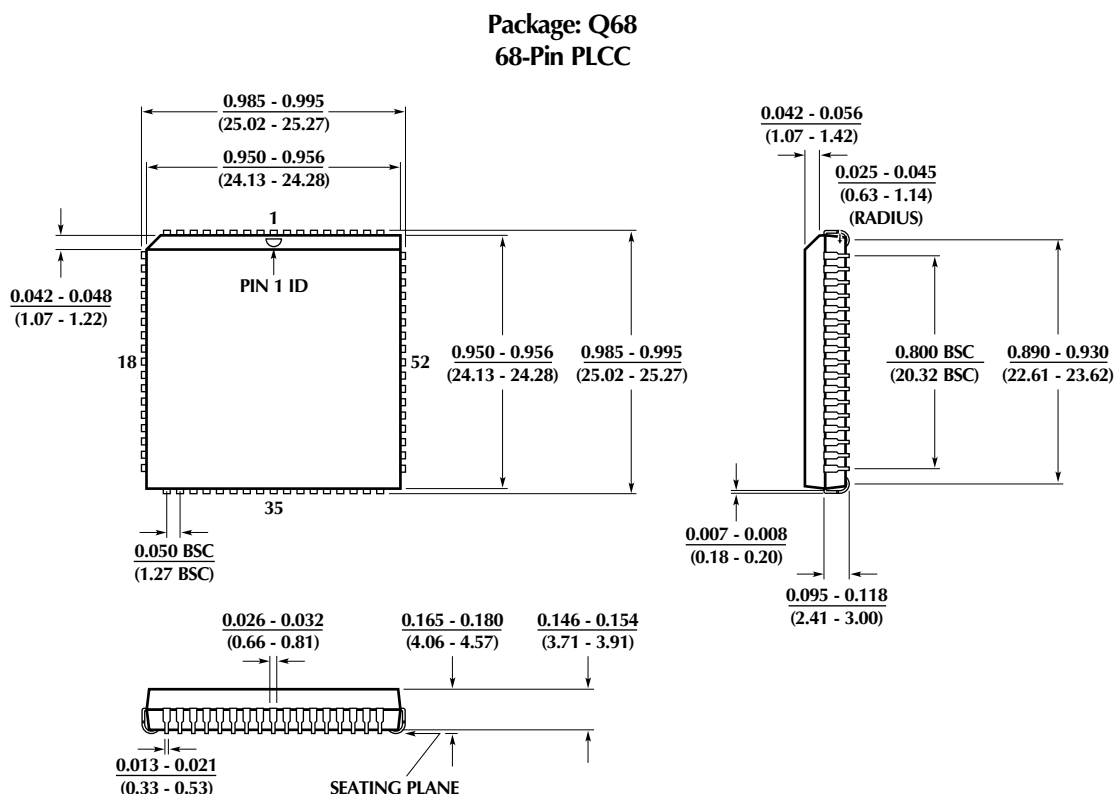

Figure 1. Four Port AUI Multiplexer.

PHYSICAL DIMENSIONS inches (millimeters)



ORDERING INFORMATION

PART NUMBER	TEMPERATURE RANGE	PACKAGE
ML4644CQ (EOL)	0°C to 70°C	68-Pin PLCC (Q68)

© Micro Linear 1997. **Micro Linear** is a registered trademark of Micro Linear Corporation. Products described in this document may be covered by one or more of the following patents, U.S.: 4,897,611; 4,964,026; 5,027,116; 5,281,862; 5,283,483; 5,418,502; 5,508,570; 5,510,727; 5,523,940; 5,546,017; 5,559,470; 5,565,761; 5,592,128; 5,594,376; Japan: 2598946; 2619299. Other patents are pending.

Micro Linear reserves the right to make changes to any product herein to improve reliability, function or design. Micro Linear does not assume any liability arising out of the application or use of any product described herein, neither does it convey any license under its patent right nor the rights of others. The circuits contained in this data sheet are offered as possible applications only. Micro Linear makes no warranties or representations as to whether the illustrated circuits infringe any intellectual property rights of others, and will accept no responsibility or liability for use of any application herein. The customer is urged to consult with appropriate legal counsel before deciding on a particular application.

2092 Concourse Drive
San Jose, CA 95131
Tel: 408/433-5200
Fax: 408/432-0295
DS4644-01