



ML6415 S-Video Filter with Summed Composite Output, Sound Trap, and Group Delay Compensation

GENERAL DESCRIPTION

The ML6415 is a dual Y/C 4th-order Butterworth lowpass video filter optimized for minimum overshoot and flat group delay. The device also contains a summing circuit to generate filtered composite video, an audio trap and group delay compensation circuit to notch-out audio, providing an area for the addition of the FM audio carrier(s) and mimic the group delay distortion introduced at the transmitter. The group delay predistortion compensates for the nominal TV receiver IF filter distortion.

In a typical application, the Y and C input signals from DACs are AC coupled into the filter. Both channels have DC restore circuitry to clamp the DC input levels during video sync. The Y and C channels use a separate feedback clamp. The clamp pulse is derived from the Y channel.

The outputs are AC coupled. The Y, C, CV, and modulator outputs can drive 2Vp-p into a 150Ω load (1Vp-p 75Ω coax load). The Y, C, CV, and notch channels have a gain of approximately 2 (6dB) with 1Vp-p input levels.

FEATURES

- 7.1MHz Y and C filters, with CV out
- 14dB notch at 4.5MHz for sound trap
- 42dB stopband attenuation at 27MHz on Y, C, and CV
- Better than 1dB flatness to 4.5 MHz on Y, C, and CV
- RF Modulator output differential group delay between 3.0MHz and 3.58MHz is typically -170ns.
- No external frequency select components or clocks
- 9ns group delay flatness on Y, C, and CV output
- 5% overshoot on Y, C, and CV output edges
- AC coupled inputs and outputs
- 0.4% differential gain on Y, C and CV channels, 0.4° differential phase on Y, C and CV channels
- 0.8% total harmonic distortion on all channels
- DC restore with low tilt

APPLICATIONS

- Cable Set-top Boxes
- Satellite Set-top Boxes
- DVD Players

TABLE OF CONTENTS

| | |
|-----------------------------------|---|
| General Description..... | 1 |
| Features | 1 |
| Applications..... | 1 |
| Warranty Information..... | 2 |
| Simplified Block Diagram | 3 |
| Pin Configuration..... | 4 |
| Pin Descriptions..... | 4 |
| Functional Description..... | 5 |
| Typical Applications Diagram..... | 6 |
| Electrical Characteristics..... | 7 |
| Electrical Tables..... | 7 |
| Physical Dimensions | 9 |
| Order Information | 9 |

WARRANTY

© Micro Linear 2000.  **Micro Linear** is a registered trademark of Micro Linear Corporation. All other trademarks are the property of their respective owners.

Products described herein may be covered by one or more of the following U.S. patents: 4,897,611; 4,964,026; 5,027,116; 5,281,862; 5,283,483; 5,418,502; 5,508,570; 5,510,727; 5,523,940; 5,546,017; 5,559,470; 5,565,761; 5,592,128; 5,594,376; 5,652,479; 5,661,427; 5,663,874; 5,672,959; 5,689,167; 5,714,897; 5,717,798; 5,742,151; 5,747,977; 5,754,012; 5,757,174; 5,767,653; 5,777,514; 5,793,168; 5,798,635; 5,804,950; 5,808,455; 5,811,999; 5,818,207; 5,818,669; 5,825,165; 5,825,223; 5,838,723; 5,844,378; 5,844,941. Japan: 2,598,946; 2,619,299; 2,704,176; 2,821,714. Other patents are pending.

Micro Linear makes no representations or warranties with respect to the accuracy, utility, or completeness of the contents of this publication and reserves the right to make changes to specifications and product descriptions at any time without notice. No license, express or implied, by estoppel or otherwise, to any patents or other intellectual property rights is granted by this document. The circuits contained in this document are offered as possible applications only. Particular uses or applications may invalidate some of the specifications and/or product descriptions contained herein. The customer is urged to perform its own engineering review before deciding on a particular application. Micro Linear assumes no liability whatsoever, and disclaims any express or implied warranty, relating to sale and/or use of Micro Linear products including liability or warranties relating to merchantability, fitness for a particular purpose, or infringement of any intellectual property right. Micro Linear products are not designed for use in medical, life saving, or life sustaining applications.

SIMPLIFIED BLOCK DIAGRAM

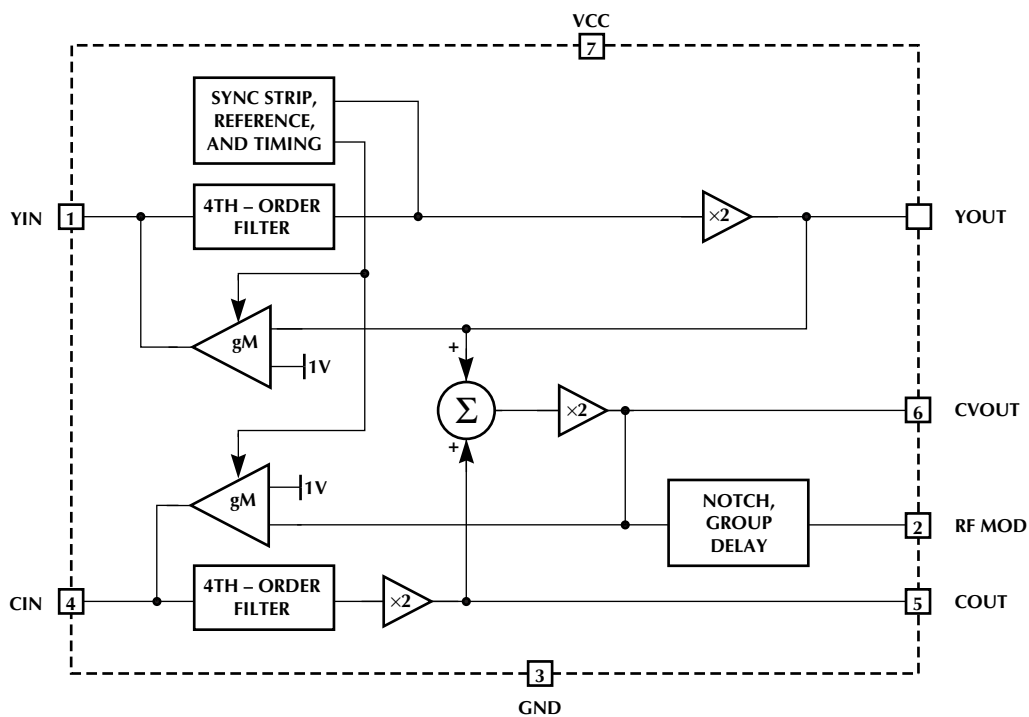

PIN CONFIGURATION

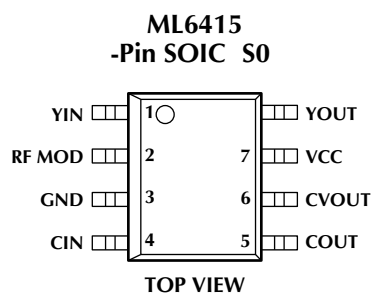

PIN DESCRIPTIONS

| PIN # | Signal Name | Description |
|-------|-------------|-------------------------------|
| 1 | YIN | Luminance input |
| 2 | RF MOD | Output to RF modulator driver |
| 3 | GND | Ground |
| 4 | CIN | Chrominance input |
| 5 | COUT | Chrominance output |
| 6 | CVOUT | Composite video output |
| 7 | VCC | 5V supply |
| 8 | YOUT | Luminance output |

FUNCTIONAL DESCRIPTION

INTRODUCTION

This product is a dual monolithic continuous time video filter designed for reconstructing the luminance and chrominance signals from an S-Video D/A source. Composite video output is generated by summing the Y and C outputs. The chip is intended for use in applications with AC coupled input and AC coupled outputs. (See Figure 1)

The reconstruction filters approximate a 4th-order Butterworth characteristic with an optimization toward low overshoot and flat group delay. Y, C, and CV outputs are capable of driving 2VP-P into AC coupled 150Ω video loads, with up to 35pF of load capacitance at the output pin.

All channels are clamped during sync to establish the appropriate output voltage swing range. Thus the input coupling capacitors do not behave according to the conventional RC time constant. Clamping for all channels settles to less than 10mv within 5ms of a change in video input sources.

In most applications the input coupling capacitors are 0.1μF. The Y and C input typically sinks 1μA during active video, which nominally tilts a horizontal line by about 2mV at the Y output. During sync, the clamp typically sources 20μA to restore the DC level. The net result is that the average input current is zero.

Any change in the input coupling capacitor's value will inversely alter the amount of tilt per line. Such a change will also linearly affect the clamp response times.

This product is robust and stable under all stated load and input conditions. Capacitive bypassing VCC directly to ground ensures this performance.

LUMINANCE (Y) I/O

The luma input is driven by either a low impedance source of 1Vp-p or the output of a 75Ω terminated line. The input is required to be AC coupled via a 0.1μF coupling capacitor which allows for a settling time of 5ms. The luma output is capable of driving an AC coupled 150Ω load at 2VP-P, or 1VP-P into a 75Ω load. Up to 35pF of load capacitance (at the output pin) can be driven without stability or slew issues. The output is AC coupled with a 400μF or larger AC coupling capacitor.

CHROMINANCE (C) I/O

The chroma input is driven by a low impedance source of 0.7Vp-p or the output of a 75Ω terminated line. The input is required to be AC coupled via a 0.1μF coupling capacitor which allows for a clamp setting time of 5ms. The chroma output is capable of driving an AC coupled 150Ω load at 2VP-P, or 1VP-P into a 75Ω load. Up to 35pF of load capacitance can be driven without stability or slew issues. A 0.1μF AC coupling capacitor is recommended at the output. (This reduces the circuit cost as chroma does not contain low frequency components.)

COMPOSITE VIDEO (CV) OUTPUT

The composite video output is capable of driving 2 loads to 2VP-P. It is intended to drive a TV and a VCR. Either the TV input or the VCR input can be shorted to ground and the other output will still meet specifications. Up to 35pF of load capacitance (at the output pin) can be driven without stability or slew issues.

RF MODULATOR OUTPUT

The RF modulator output is capable of driving a 600Ω load to 2VP-P, but is primarily intended to drive a modulator load.

TYPICAL APPLICATIONS DIAGRAM

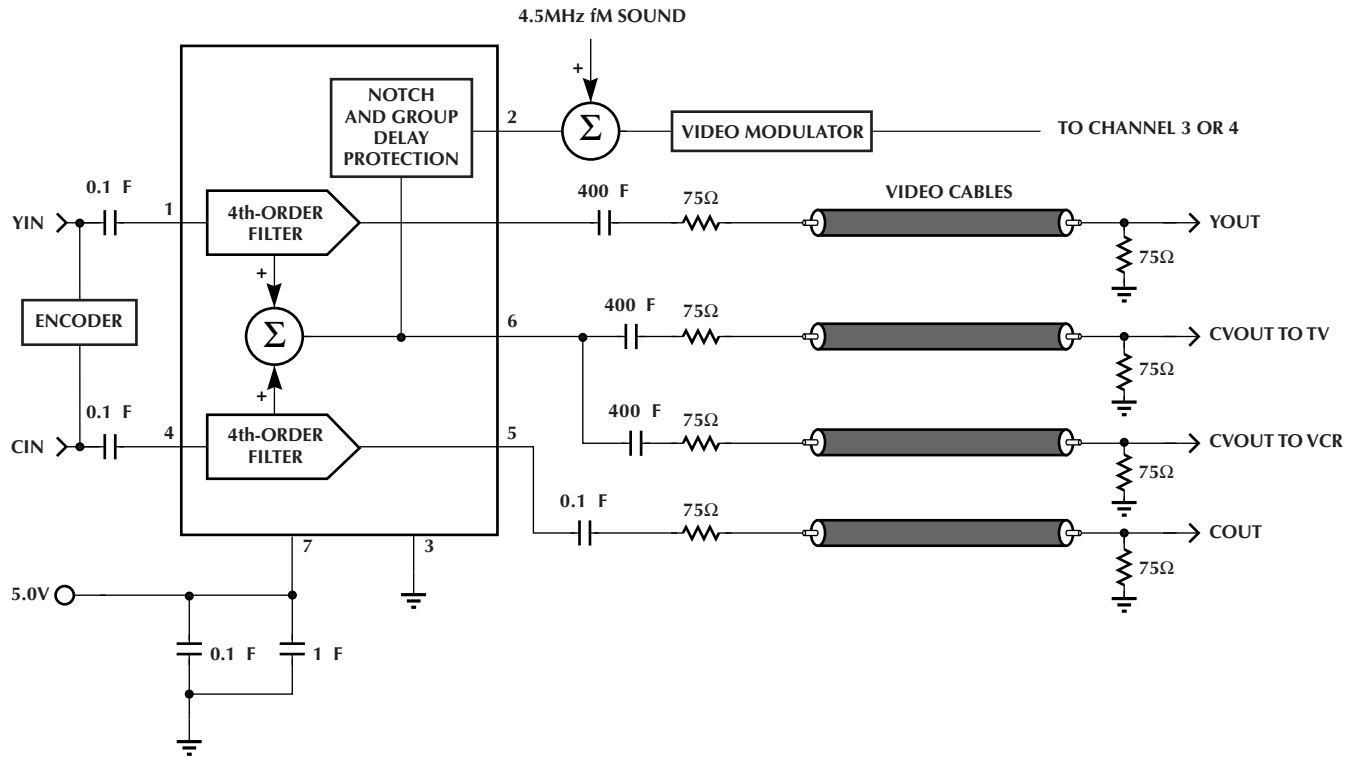

Figure 1. Coupled S-Video, Composite Video Line Driver, Sound Trap, and Group Delay Pre-distortion

ELECTRICAL CHARACTERISTICS

ABSOLUTE MAXIMUM RATINGS

Absolute maximum ratings are those values beyond which the device could be permanently damaged. Absolute maximum ratings are stress ratings only and functional device operation is not implied.

DC Supply Voltage -0.3V to 7V
 Analog & Digital I/O..... GND – 0.3V to VCC + 0.3V
 Output Current (Continuous)
 CV Channel60mA
 C and Y Channels30mA
 Junction Temperature 150°C
 Storage Temperature Range-65°C to 150°C
 Lead Temperature (Soldering, 10s)..... 260°C
 Thermal Resistance (θ JA) 115°C/W

OPERATING CONDITIONS

Temperature Range 0°C to 70°C
 VCC Range..... 4.5V to 5.5V

ELECTRICAL TABLES

Unless otherwise specified, VCC = 5.0V \pm 10%, All inputs AC coupled with 100nF, TA = Operating Temperature Range

| SYMBOL | PARAMETER | CONDITIONS | MIN | TYP | MAX | UNITS |
|--------|---|---|------|------|------|-------|
| ICC | Supply Current | No Load | | 60 | 75 | mA |
| VCC | Supply Range | | 4.5 | 5.0 | 5.5 | V |
| AV | Low Frequency Gain (Y, C) | VIN = 100mVP-P at 400KHz | 5.75 | 6.0 | 6.25 | dB |
| AV | Low Frequency Gain (modulator) | VIN = 100mVP-P at 400KHz | 6.1 | 6.7 | 7.3 | dB |
| | Low Frequency Gain (CV) | VIN = 100mVP-P at 400KHz | 5.4 | 5.75 | 6.25 | dB |
| | C DC Output Level (During Sync) | Sync Present on Y | 1.6 | 2.0 | 2.4 | V |
| | Y Sync Output Level | Sync Present on Y | 0.75 | 1.0 | 1.25 | V |
| | Y+C Sync Output Level | Sync Present on Y | 0.75 | 1.0 | 1.25 | V |
| | Notch Output Level | Sync Present on Y | 0.65 | 1.0 | 1.35 | V |
| tCLAMP | Clamp Response Time (Y Channel) | Settled to Within 10mV | | 5 | | ms |
| f1dB | -1.0dB Bandwidth (Flatness) (Y, C, and CV) | | 4.0 | 4.5 | | MHz |
| fC | -3dB Bandwidth (Flatness) (Y, C, and CV) | | | 7.1 | | MHz |
| 0.8fC | 0.8 x fC Attenuation (Y, C) | | | 1.5 | | dB |
| fSB | Stopband Rejection (Y, C, and CV) | fIN = 27MHz to 100MHz worst case | -37 | -42 | | dB |
| Vi | Input Signal Dynamic Range (All Channels) | AC Coupled | | 1.4 | | VP-P |
| OS | Peak Overshoot (Y, C, and CV) | 2VP-P Output Pulse (loaded) | | 4.3 | | % |
| ISC | Output Short Circuit Current (All Channels) | VOU C, Y, CV, or notch to GND (Note 1) | | 40 | 80 | mA |
| CL | Output Shunt Capacitance Drive (All Channels) | All Outputs | | 35 | | pF |
| dG | Differential Gain | Y, C, and CV Outputs | | 0.4 | | % |
| dP | Differential Phase | Y, C, and CV Outputs | | 0.4 | | ° |
| THD | Output Distortion (All Channels) | VOU = 1.8VP-P, Y/C Out at 3.58MHz | | 0.8 | | % |
| XTALK | Crosstalk | From C Input of 0.5VP-P at 3.58MHz to Y Output | | -55 | | dB |
| | | From Y Input of 0.4VP-P at 3.58MHz, to C Output | | -58 | | dB |
| PSRR | PSRR (All Channels) | 0.5VP-P (100kHz) at VCC | | -40 | | dB |

ELECTRICAL TABLES (CONTINUED)

| SYMBOL | PARAMETER | CONDITIONS | MIN | TYP | MAX | UNITS |
|--------|--|----------------------------------|------|-------|-------|-------|
| tpd | Group Delay (Y, C, CV) | 100kHz | | 70 | | ns |
| SNR | Y, C Channel | NTC-7 weighting 4.2 MHz lowpass | | -75 | | dB |
| | CV Channel | NTC-7 weighting 4.2 MHz lowpass | | -69 | | dB |
| | Mod Channel | NTC-7 weighting 4.2 MHz lowpass | | -60 | | dB |
| Δtpd | Group Delay Deviation from Flatness (Y, C, and CV) | to 3.58MHz (NTSC) | | 9 | | ns |
| tSKEW | Skew Between Y & C Outputs | at 1MHz | | 0 | | ns |
| Tpd | Group Delay RF Modulator Output | f = 3.58MHz (referenced to 3MHz) | -130 | -170 | -230 | ns |
| dG | Differential Gain | Modulator Channel | | 1.5 | | % |
| dP | Differential Phase | Modulator Channel | | 1.0 | | ° |
| pK | Gain Peaking (Note 2) | Modulator Channel at 2.0MHz | | 0.5 | 0.75 | dB |
| MCF | Modulator Channel Flatness (Note 2) | at 3.75MHz | -0.5 | | +0.75 | dB |
| AV | Notch Attenuation (Note 2) | From 4.37MHz to 4.63MHz | 14 | | | dB |
| PSRRmt | Supply Sensitivity Modulator Channel Flatness | VCC=4.5V to 5.5V at 3.8MHz | | 0.12 | | dB/V |
| TCm | Modulator Channel Flatness Temperature Sensitivity | VCC=5V 3.8MHz | | -0.04 | | dB/°C |

Note 1: Sustained short circuit protection limited to 10 seconds

Note 2: Referenced to 300KHz

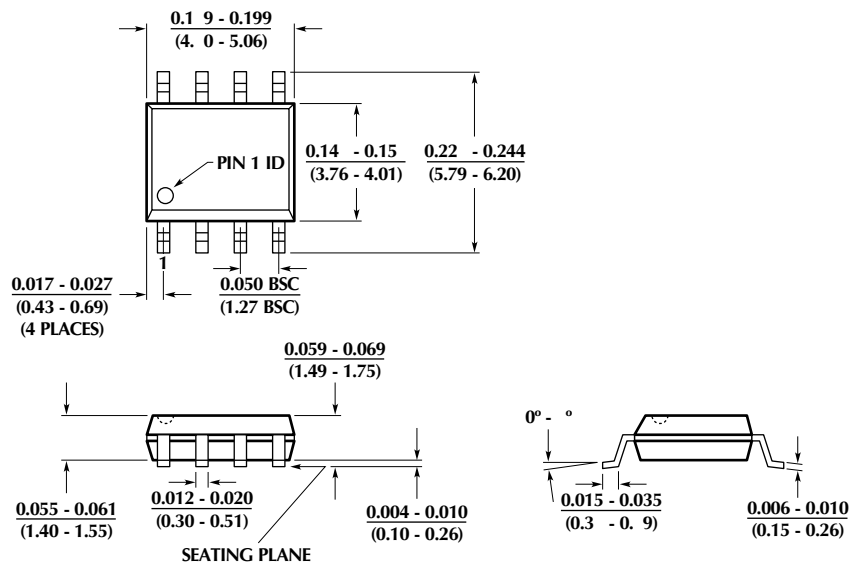
PHYSICAL DIMENSIONS
**Package S0
-Pin SOIC**

ORDERING INFORMATION

| PART NUMBER | TEMPERATURE RANGE | PACKAGE |
|-------------|-------------------|------------------|
| ML6415CS | 0° to 70° | 8 Pin SOIC (S08) |

Micro Linear Corporation
 2092 Concourse Drive
 San Jose, CA 95131
 Tel: (408) 433-5200
 Fax: (408) 432-0295
www.microlinear.com