

ML6554

3A Bus Termination Regulator

Features

- Can source and sink up to 3A, no heat sink required
- Integrated Power MOSFETs
- Generates termination voltages for DDR SDRAM, SSTL-2 SDRAM, SGRAM, or equivalent memories
- Generates termination voltages for active termination schemes for DDR SDRAM, GTL+, Rambus, VME, LV-TTL, HSTL, PECL and other high speed logic
- V_{REF} input available for external voltage divider
- Separate voltages for V_{CCQ} and PV_{DD}
- Buffered V_{REF} output
- V_{OUT} of $\pm 3\%$ or less at 3A
- Minimum external components
- Shutdown for standby or suspend mode operation
- 0° to $+70^\circ\text{C}$ and -40° to $+85^\circ\text{C}$ temperature ranges available
- Thermal Shutdown $\approx 130^\circ\text{C}$

Description

The ML6554 switching regulator is designed to convert voltage supplies ranging from 2.3V to 4V into a desired output voltage or termination voltage for various applications. The ML6554 can be implemented to produce regulated output voltages in two different modes. In the default mode, when the V_{REF} pin is open, the ML6554 output voltage is 50% of the voltage applied to V_{CCQ} . The ML6554 can also be used to produce various user-defined voltages by forcing a voltage on the V_{REFIN} pin. In this case, the output voltage follows the input V_{REFIN} voltage. The switching regulator is capable of sourcing or sinking up to 3A of current while regulating an output V_{TT} voltage to within 3% or less.

The ML6554, used in conjunction with series termination resistors, provides an excellent voltage source for active termination schemes of high speed transmission lines as those seen in high speed memory buses and distributed backplane designs. The voltage output of the regulator can be used as a termination voltage for other bus interface standards such as DDR SDRAM, SSTL, CMOS, Rambus™, GTL+, VME, LV-CMOS, LV-TTL, HSTL and PECL.

Block Diagram

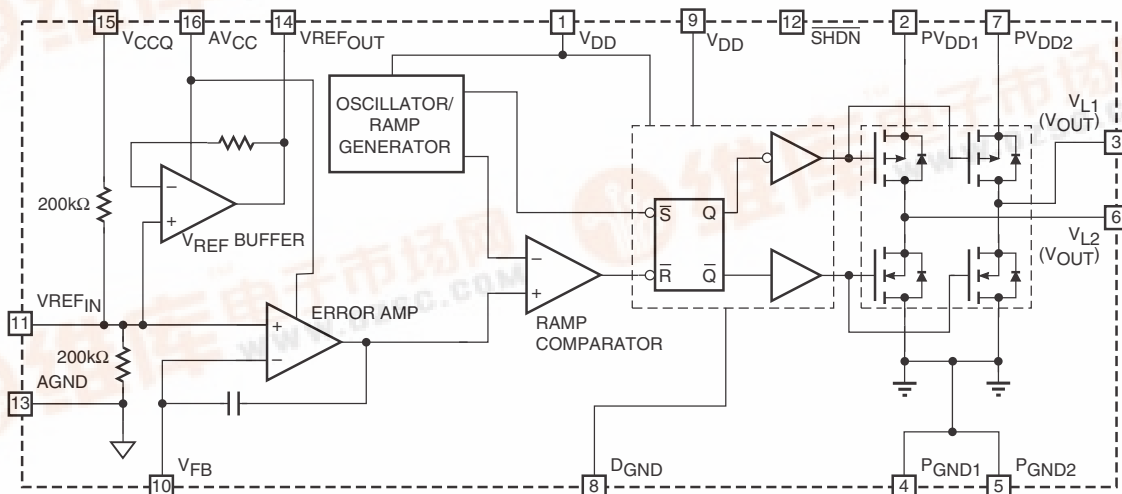

Pin Configuration

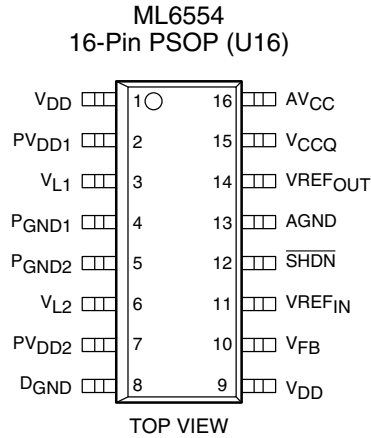

Pin Description

Pin	Name	Function
1	V_{DD}	Digital supply voltage
2	PV_{DD1}	Voltage supply for internal power transistors
3	V_{L1}	Output voltage/ inductor connection
4	P_{GND1}	Ground for output power transistors
5	P_{GND2}	Ground for output power transistors
6	V_{L2}	Output voltage/inductor connection
7	PV_{DD2}	Voltage supply for internal power transistors
8	D_{GND}	Digital ground
9	V_{DD}	Digital supply voltage
10	V_{FB}	Input for external compensation feedback
11	$VREF_{IN}$	Input for external reference voltage
12	\overline{SHDN}	Shutdown active low. CMOS input level
13	$AGND$	Ground for internal reference voltage divider
14	$VREF_{OUT}$	Reference voltage output
15	V_{CCQ}	Voltage reference for internal voltage divider
16	AV_{CC}	Analog voltage supply

Absolute Maximum Ratings

Absolute maximum ratings are those values beyond which the device could be permanently damaged. Absolute maximum ratings are stress ratings only and functional device operation is not implied.

Parameter	Min.	Max.	Units
PV _{DD}		4.5	V
Voltage on Any Other Pin	GND – 0.3	V _{IN} + 0.3	V
Average Switch Current (I _{AVG})		3.0	A
Junction Temperature		150	°C
Storage Temperature Range	-65	150	°C
Lead Temperature (Soldering, 10 sec)		150	°C
Thermal Resistance (θ _{JC})(Note 2)		2	°C/W
Output Current, Source or Sink		3.0	A

Operating Conditions

Parameter	Min.	Max.	Units
Temperature Range, CU suffix	0	70	°C
Temperature Range, IU suffix	-40	+85	°C
PV _{DD} Operating Range	2.0	4.0	V
V _{CCQ} Operating Range	1.4	4.0	V

Electrical Characteristics

Unless otherwise specified, AV_{CC} = V_{DD} = PV_{DD} = 3.3V ±10%, TA = Operating Temperature Range (Note 1)

Symbol	Parameter	Conditions	Min.	Typ.	Max.	Units	
Switching Regulator							
V _{TT}	Output Voltage, SSTL_2 (See Figure 1)	I _{OUT} = 0, V _{REF} = open	V _{CCQ} = 2.3V	1.12	1.15	1.18	V
			V _{CCQ} = 2.5V	1.22	1.25	1.28	V
			V _{CCQ} = 2.7V	1.32	1.35	1.38	V
		I _{OUT} = ±3A, V _{REF} = open	V _{CCQ} = 2.3V	1.09	1.15	1.21	V
			V _{CCQ} = 2.5V	1.19	1.25	1.31	V
			V _{CCQ} = 2.7V	1.28	1.35	1.42	V
V _{REF_OUT}	Internal Resistor Divider	I _{OUT} = 0	V _{CCQ} = 2.3V	1.139	1.15	1.162	V
			V _{CCQ} = 2.5V	1.238	1.25	1.263	V
			V _{CCQ} = 2.7V	1.337	1.35	1.364	V
Z _{IN}	V _{REF} Reference Pin Input Impedance		V _{CCQ} = 0		100		kΩ
				Switching Frequency		650	
ΔV _{OFFSET}	Offset Voltage V _{TT} – V _{REF_OUT}	AV _{CC} = 2.5V No Load	V _{CCQ} = 2.5	-20		20	mV
Supply							
I _Q	Quiescent Current	I _{OUT} = 0, no load V _{CCQ} = 2.5V	I _{VCCQ}		6	10	μA
			I _{AVCC}		0.5	1.0	mA
			I _{AVCC SD}		0.2	0.5	mA
			I _{VDD}		0.25	1.0	mA
			I _{VDD SD}		0.2	1.0	mA
			I _{PVDD}		100	250	μA
Buffer							
I _{REF}	Output Load Current		3			mA	

Notes

- Limits are guaranteed by 100% testing, sampling, or correlation with worst-case test conditions.
- Infinite heat sink

Functional Description

This switching regulator is capable of sinking and sourcing 3A of current without an external heatsink. The ML6554 uses a power surface mount package (PSOP) that includes an integrated heat slug. The heat can be piped through the bottom of the device and onto the PCB (Figure 1).

The ML6554 integrates two power MOSFETs that can be used to source and sink 3A of current while maintaining a tight voltage regulation. Using the external feedback, the output can be regulated well within 3% or less, depending on the external components chosen. Separate voltage supply inputs have been added to accommodate applications with various power supplies for the databus and power buses, see Figure 2.

Outputs

The output voltage pins (V_{L1} , V_{L2}) are tied to the databus, address, or clock lines via an external inductor. See the Applications section for recommendations. Output voltage is determined by the V_{CCQ} or $V_{REF_{IN}}$ inputs.

Inputs

The input voltage pins (V_{CCQ} or $V_{REF_{IN}}$) determine the output voltages (V_{L1} or V_{L2}). In the default mode, where the $V_{REF_{IN}}$ pin is floating, the output voltage is 50% of the V_{CCQ} input. V_{CCQ} can be the reference voltage for the databus.

Output voltage can also be selected by forcing a voltage at the $V_{REF_{IN}}$ pin. In this case, the output voltage follows the voltage at the $V_{REF_{IN}}$ input. Simple voltage dividers can be used in this case to produce a wide variety of output voltages between 0.7V and $V_{DD}-0.7V$.

VREF Input and Output

The $V_{REF_{IN}}$ input can be used to force a voltage at the outputs (Inputs section, above). The $V_{REF_{OUT}}$ pin is an output pin that is driven by a small output buffer to provide the V_{REF} signal to other devices in the system. The output buffer is capable of driving several output loads. The output buffer can handle 3mA.

Other Supply Voltages

Several inputs are provided for the supply voltages: PV_{DD1} , PV_{DD2} , AV_{CC} , and V_{DD} .

The PV_{DD1} and PV_{DD2} provide the power supply to the power MOSFETs. V_{DD} provides the voltage supply to the digital sections, while AV_{CC} supplies the voltage for the analog sections. Again, see the Applications section for recommendations.

Feedback Input

The V_{FB} pin is an input that can be used for closed loop compensation. This input is derived from the voltage output. See application section for recommendation.

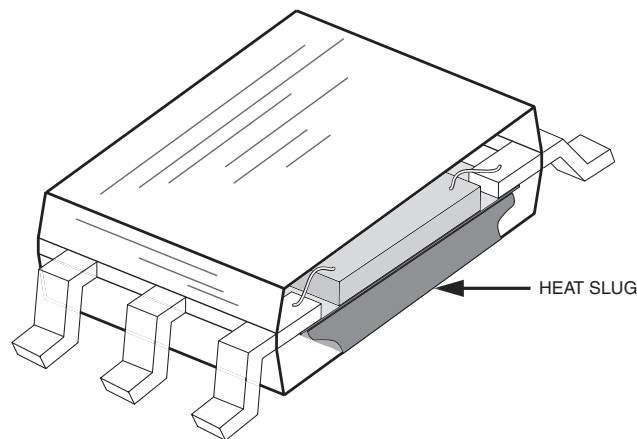

Figure 1. Cutaway view of PSOP Package

Applications

Using the ML6554 for SSTL Bus Termination

The circuit schematic in Figure 2 shows a recommended approach for constructing a bus terminating solution for an SSTL-2 bus. This circuit can be used in PC memory and Graphics memory applications as shown in Figures 4 and 5. Note that the ML6554 can provide the voltage reference (V_{REF}) and terminating voltages (V_{TT}). Using the layout as shown in Figures 6, 7, and 8, and measuring the V_{TT} performance using the test setup as described in Figure 9, the ML6554 delivered a $V_{TT} \pm 20\text{mV}$ for 1A to 3A loads (see Figure 10). Table 1 provides a recommended parts list for the circuit in Figure 2.

Power Handling Capability of the PSOP Package

Using the board layout shown in Figures 6, 7, and 8; soldering the ML6554 to the board at zero LFPM the temperature around the package measured 55°C for 3A loads. Note that a 1 ounce copper plane was used in the board construction.

Airflow is not likely to be needed in the operation of this device (assuming a board layout similar to that described above). The power handling performance of the PSOP package is shown by a study of the package manufacturer for various airflow vs. θ_{JA} conditions in Figure 11.

Bus Termination Solutions for Others Buses

Table 3 provides a summary of various bus termination V_{REF} & V_{TT} requirements. The ML6554 can be used for those applications.

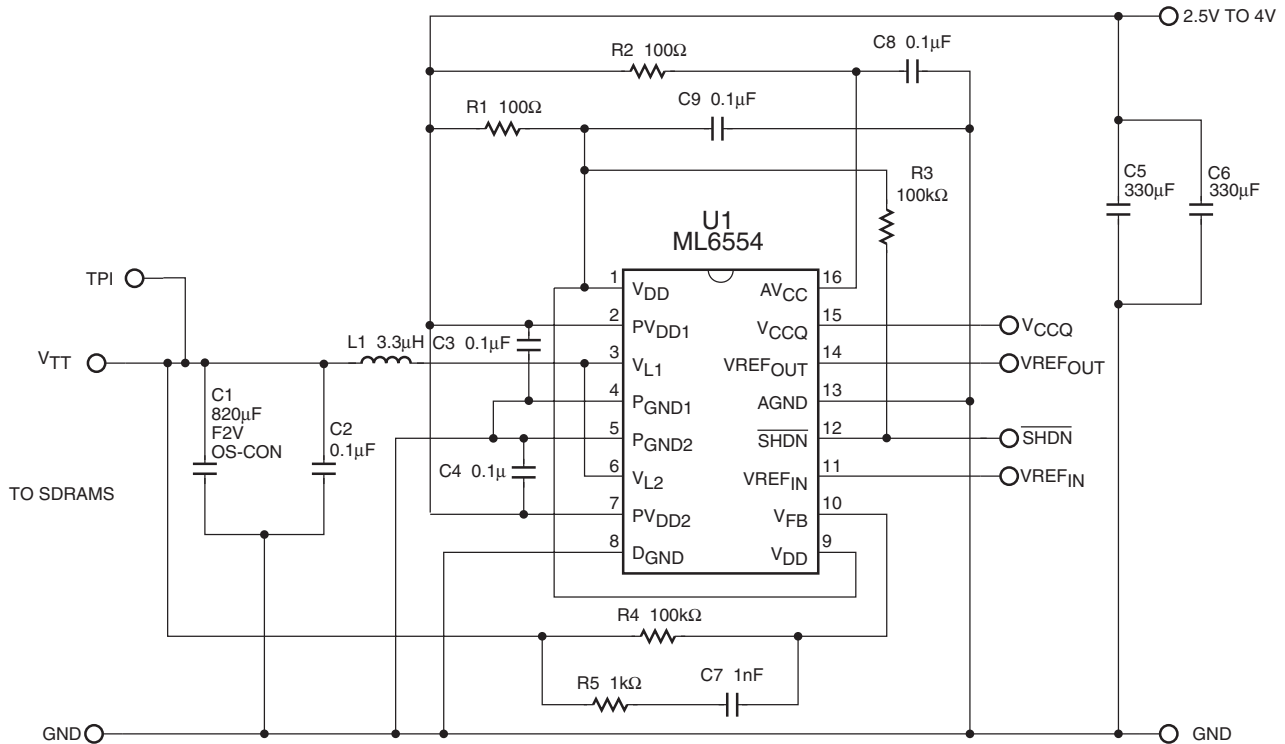

Figure 2.

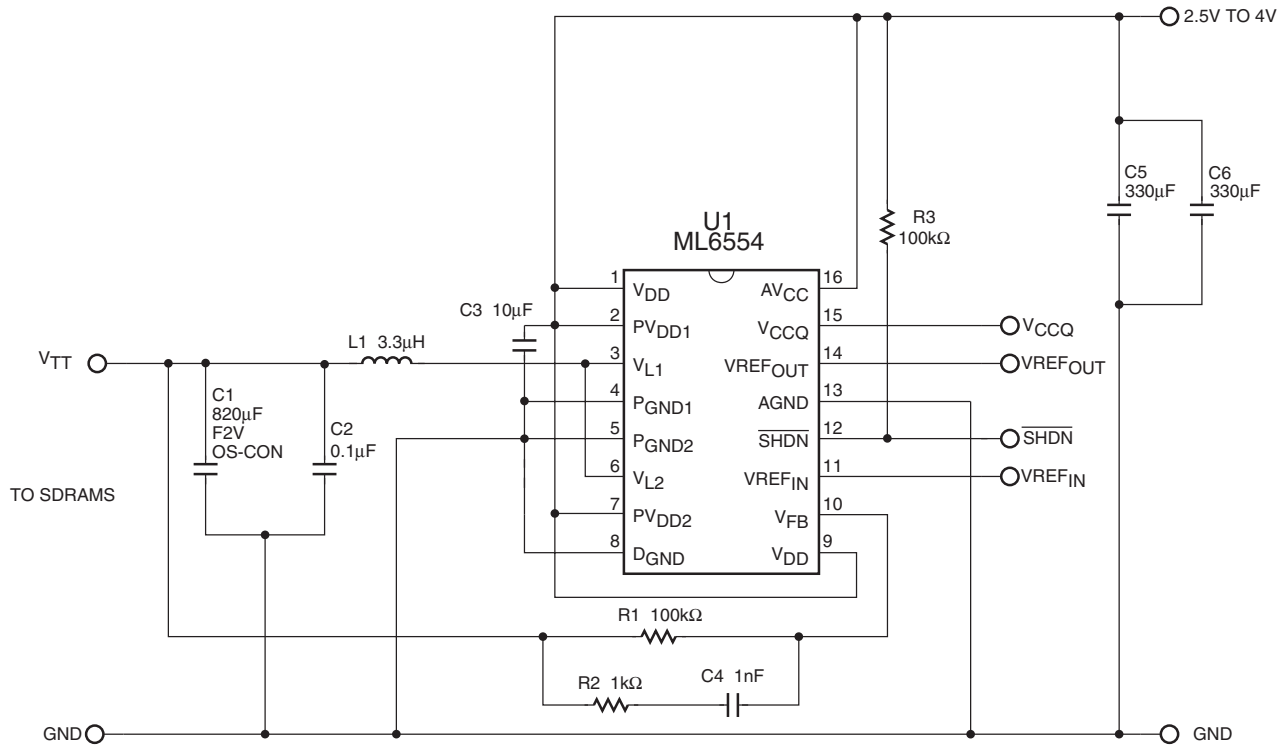

Figure 3. Alternate Application Circuit

An alternate application circuit for the ML6554 is shown in Figure 3. The number of external components is reduced compared to the circuit in Figure 2. This is achieved by replacing four, 0.1µF bypass capacitors with one, low ESR, 10µF ceramic capacitor placed right next to U1. Two 100Ω resistors are also eliminated. High value, surface-mount

MLC capacitors were not available when the original application circuit (Figure 2) was developed. Both application circuits offer the same electrical performance but that shown in Figure 2 has a reduced bill-of-materials. Table 2 shows the recommended parts list for the circuit of Figure 3.

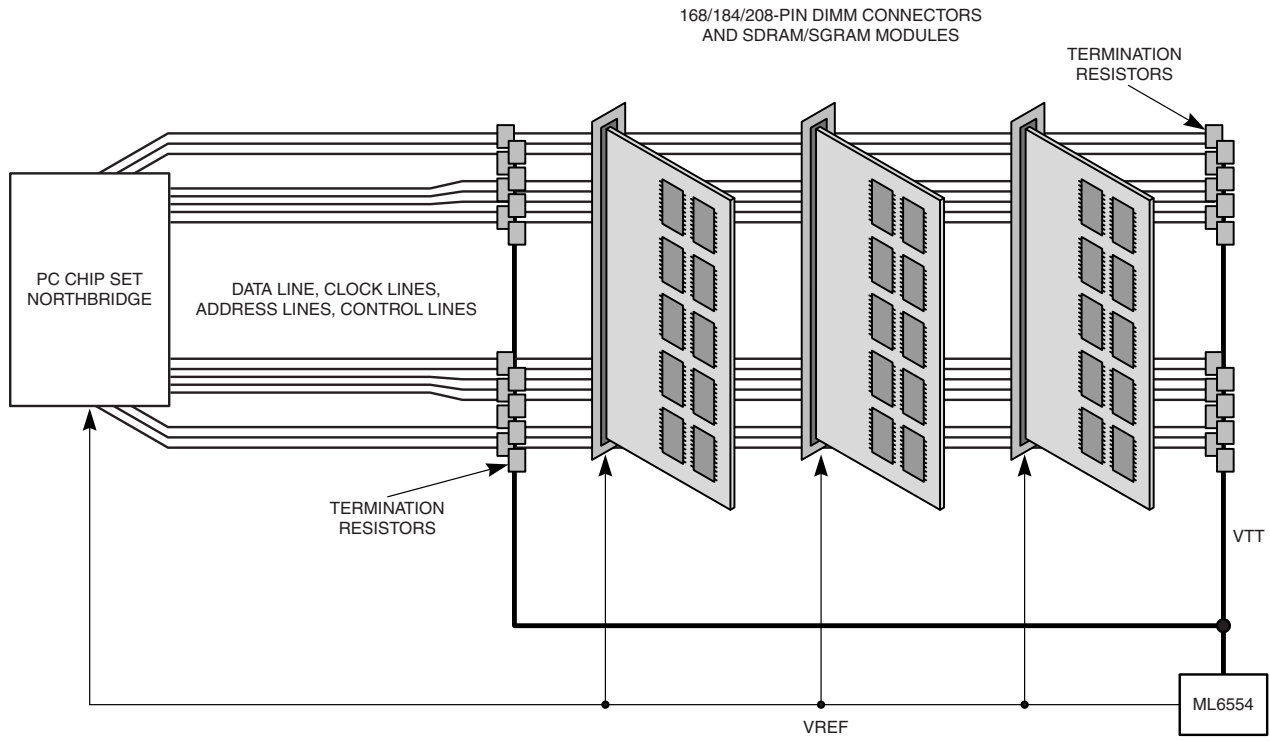

Figure 4. Complete Termination Solution PC Main Memory (PC Motherboard)

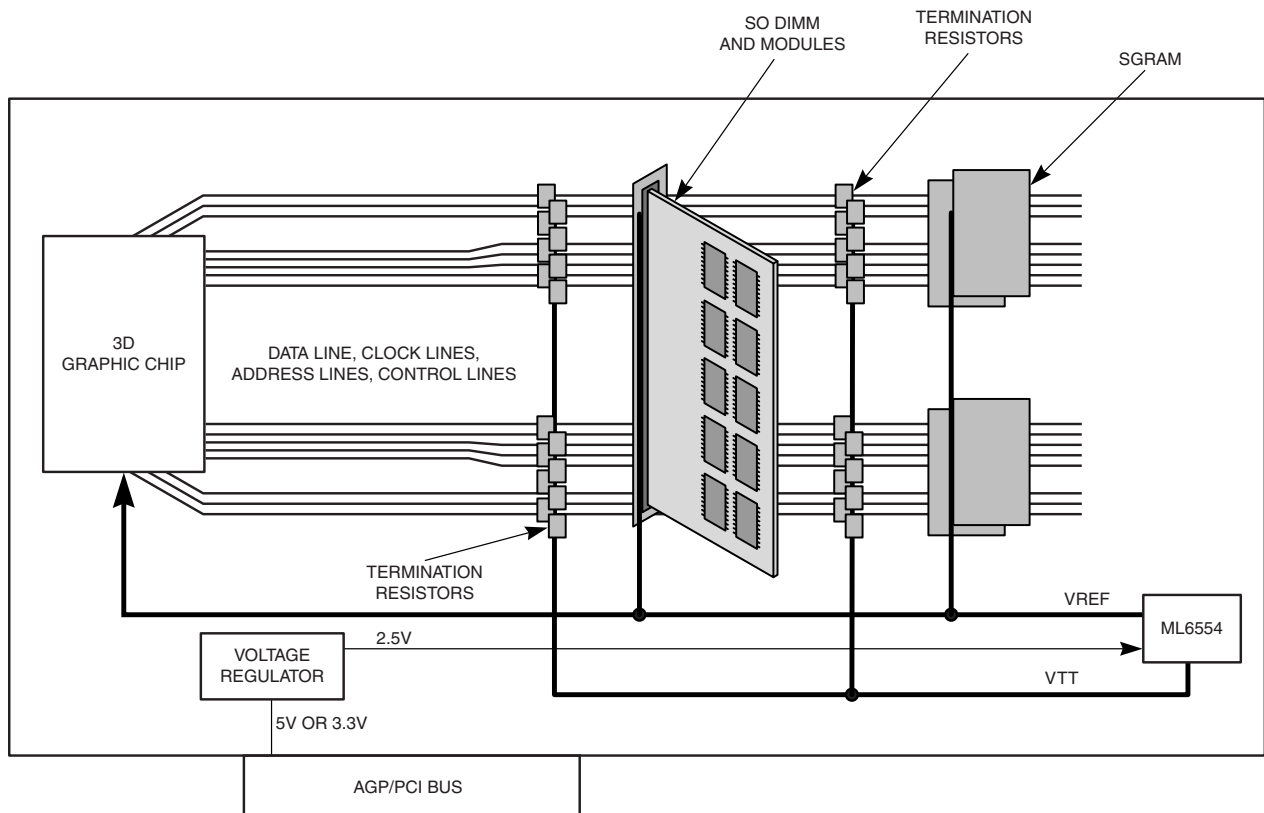

Figure 5. Complete Termination Solution Graphics Memory Bus – AGP Graphics Cards

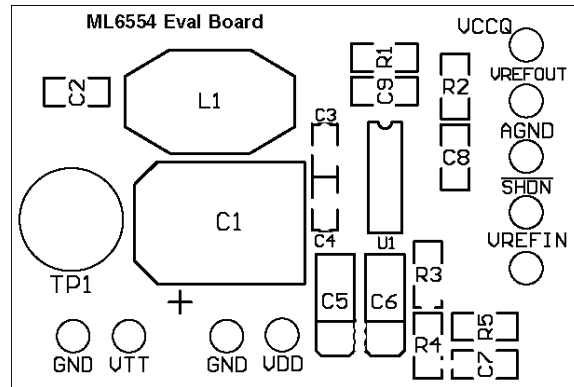

Figure 6. Top Silk

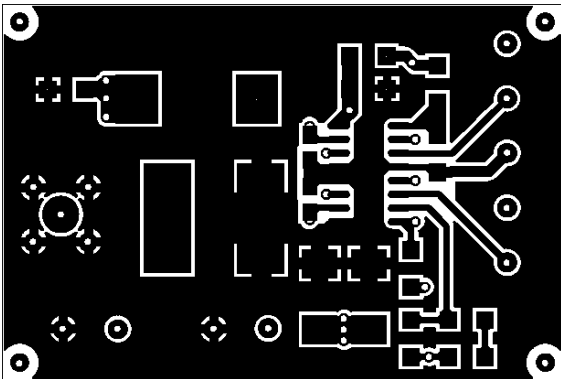

Figure 7. Top Layer

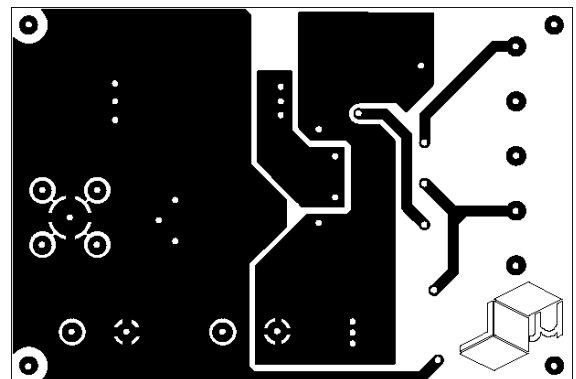

Figure 8. Bottom Layer

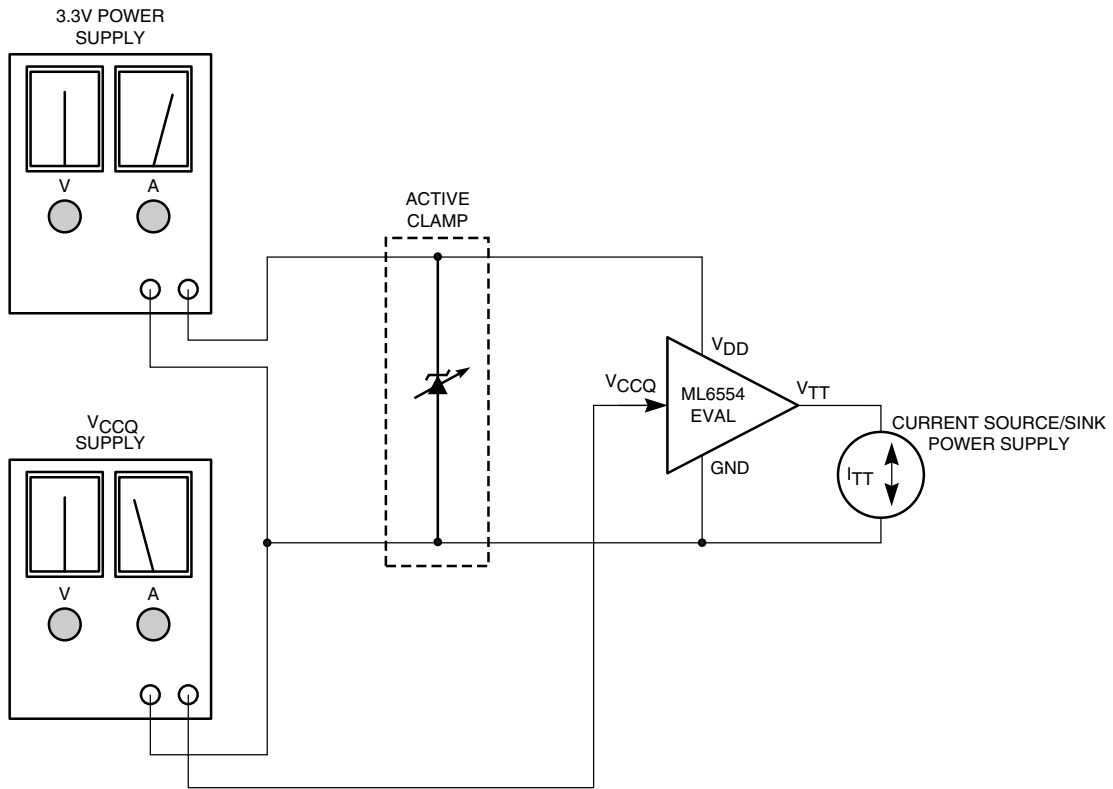

Figure 9. Test Circuit Setup

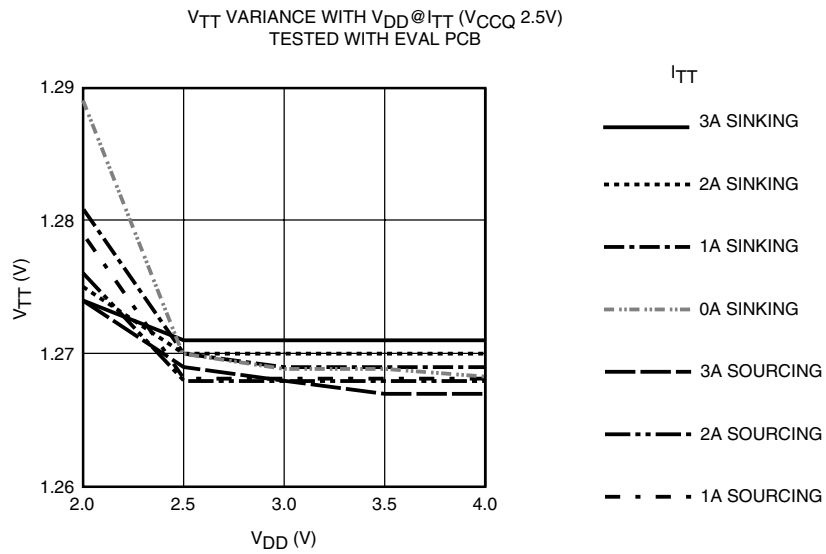

Figure 10. VTT Performance for SSTL-2 Bus

Table 1. Recommend Parts List for SSTL-2 Termination Circuit in Figure 2.

Item	Qty	Description	Manufacturer / Part Number	Designator
Resistors				
1	2	100Ω1210 SMD	Panasonic/ERJ-8ENF1000V	R1, R2
2	1	1kΩ 1210 SMD	Panasonic/ERJ-8ENF1001V	R5
3	2	100kΩ1210 SMD	Panasonic/ERJ-8ENF1003V	R3, R4
Capacitors				
4	3	0.1μF 1210 Film SMD	Panasonic/ECV3VB1E104K Panasonic/ECU-V1H104KBW	C2, C8, C9
5	1	820μF 2V Solid Elect. SMD	Sanyo/2SV820M Os Con	C1
6	2	330μF Tant 6.3V 100mΩ	AVX/TPSE337M006R0100	C5, C6
7	1	1nF 1210 Film SMD	Panasonic/ECU-V1H102KBM	C7
8	2	0.1μF 0805 Film	Panasonic/ECJ-2VF1C104Z	C3, C4
ICS				
9	1	ML6554 Bus Terminator Power SOP Package	ML6554CU or ML6554IU	U1
Magnetics				
10	1	3.3μH 5A inductor SMD	Coilcraft/D03316P-332HC Pulse Eng./ P0751.332T Gowanda/SMP3316-331M XFMRs inc./XF0046-S4	L1
Other				
11	1	Scope probe socket	Tektronics/131-4353-00	TP1
12	1	12 Pin breakaway strip	Sullins/PTC36SAAN (36 PINS)	I/O, standoffs

Table 2. Recommend Parts List for Figure 3.

Item	Qty	Description	Manufacturer / Part Number	Designator
Resistors				
1	2	100kΩ 0805 SMD	Panasonic/ERJ-8ENF1000V	R1, R3
2	1	1kΩ 0805 SMD	Panasonic/ERJ-8ENF1000V	R2
Capacitors				
3	1	0.1μF, 1210 Film SMD	Panasonic/ECV3VB1E104K Panasonic/ECU-V1H104KBW	C2
4	1	820μF 2V Solid Elect. SMD	Sanyo/2SV820M Os Con	C1
5	2	330μF Tant 6.3V 100mΩ	AVX/TPSE337M006R0100	C5, C6
6	1	1nF 1210 Film SMD	Panasonic/ECU-V1H102KBM	C4
7	1	10μF 6.3V Ceramic	TDK/C2012X5R0J106M	C3
ICS				
8	1	ML6554 Bus Terminator Power SOP Package	ML6554CU or ML6554IU	U1
Magnetics				
9	1	3.3μH 5A inductor SMD	Coilcraft/D03316P-332HC Pulse Eng./ P0751.332T Gowanda/SMP3316-331M XFMRs inc./XF0046-S4	L1
Other				
10	1	Scope probe socket	Tektronics/131-4353-00	TP1
11	1	12 Pin breakaway strip	Sullins/PTC36SAAN (36 PINS)	I/O, standoffs

Vendor List

1. AVX (207) 282-5111
2. Sanyo (619) 661-6835
3. Tektronix (408) 496-0800
4. Coilcraft (847) 639-6400
5. Pulse (800) 797-8573
6. Gowanda (716) 532-2234
7. Xfmrs Inc. (317) 834-1066
8. Panasonic (714) 373-7366
9. Digikey (800) 344-4539

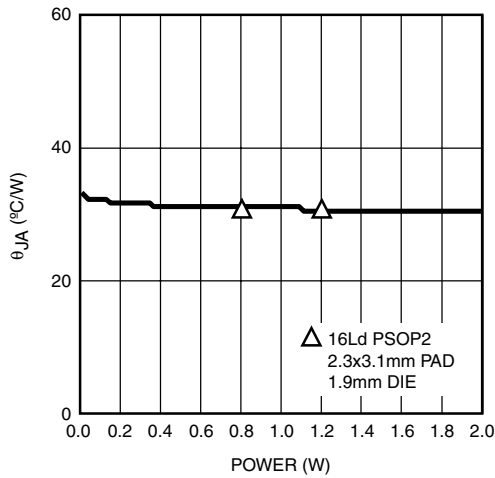

NATURAL CONVECTION θ_{JA} TEST RESULTS
 1.27mm PITCH PowerSOP™ 2
 SLUG SOLDERED

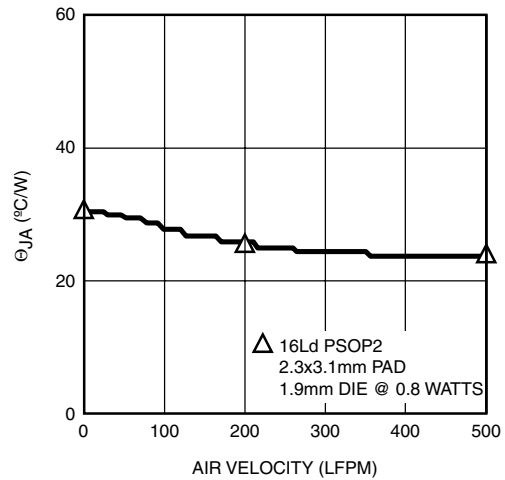

FORCED CONVECTION θ_{JA} TEST RESULTS
 1.27mm PITCH PowerSOP™ 2
 SLUG SOLDERED

Figure 11. Graphical Results Summary – 1S2P Test Board

DRAWING NUMBER	ENG-CB-1007 REV A
Applicable Jedec Spec	JC 51-X (Note 1) (Proposed Spec)
Substrate Material	FR-4
Dimensions (LxW) (Overall)	114.3 x 76.2mm
Dimensions (LxW) (Metallization)	55 x 65mm
Dimensions (LxW) (Inner Planes)	73 x 73mm
Thickness	1.6 mm
Pitch	1.27mm
Stackup (# Signal Layers, # Cu Planes)	1S2P
Cu Trace Coverage (Signal Layer)	12%
Cu Coverage (Internal Layer)	100%
Trace Width (Spec/Measured)	235.5±25.5/288µm
Trace Cu Thickness (Spec/Measured)	70±14/67µm
Inner Cu Thickness (Spec/Measured)	35±3.5/31µm
Build #	C1797

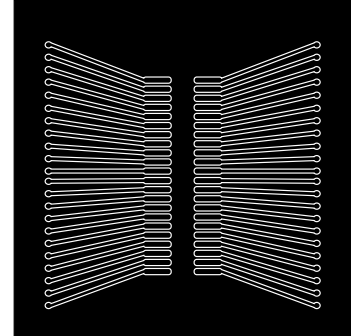

Note 1: Proposed Spec "Thermal Test Board with Two Internal Solid Copper Planes for leaded Surface Mount Packages".

Figure 12. Test Board Layout for Θ_{JA} vs. Airflow

Table 3. Termination Solutions Summary By Buss Type

Bus	Description	Driving Method	VDDQ	VTT	VREF	Fairchild Solutions	Industry System Components
GTL+	Gunning Transceiver Bus Plus	Open Drain	5v or 3.3V Note 10	1.5V±10% Note12	1.0V±2% Note 11	ML6554CU; Mode: VREF Input = 1.5V, VCC = 5V	300 to 500MHz Processor; PC Chipsets; GTL 16xxx Buffers; Fairchild, Texas Instr.
SSTL_2	Series Stub Terminated Logic for 2V	Symmetric Drive, Series Resistance	2.5V±10%	0.5x (VDDQ) ±3%	2.5V	ML6554CU or ML6553CS; Mode: VREF Input = Floating or Forced, VCC = 3.3V	SSTL SDRAM; Hitachi, Fujitsu, NEC, Micro, Mitsubishi
RAMBUS	RAMBUS Signaling Logic	Open Drain	None Specified	2.5V	2.0V	ML6553CS; Mode: VREF Input = Open, VCC = VDDQ	nDRAM, RAMBUS, Intel, Toshiba
LV-TTL	Low Voltage TTL Logic or PECL or 3.3V VME	Symmetric Drive	3.3±10%	VDDQ/2	3.3V	ML6553CS; Mode: VREF Input = Open, VCC = VDDQ	Processors or backplanes; LV-TTL SDRAM, EDO RAM

Mechanical Dimensions

16-Pin PSOP

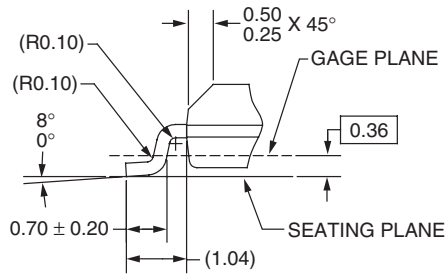
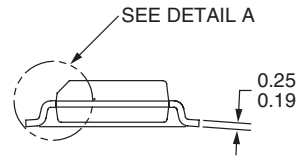
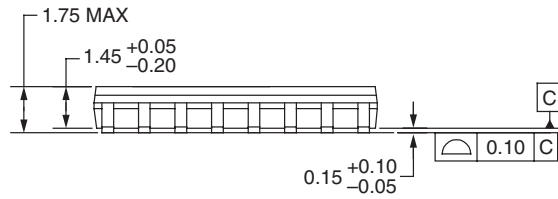
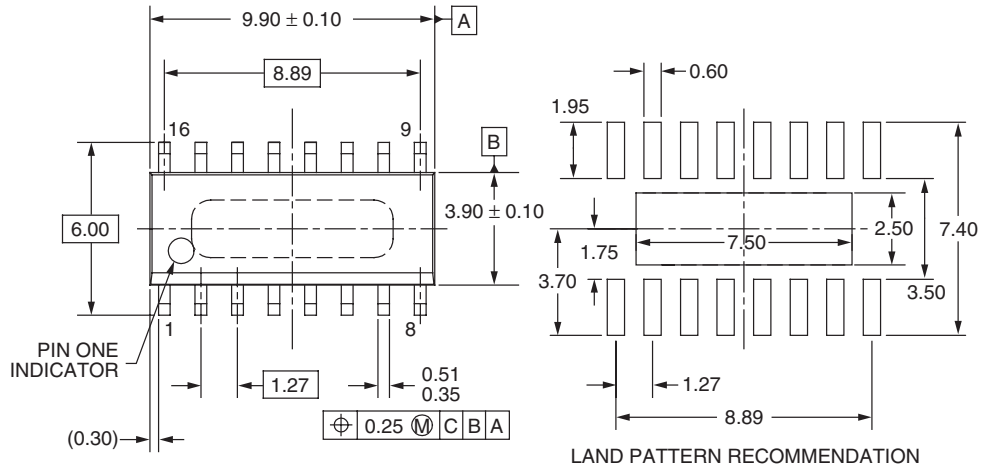

DETAIL A
SCALE: 2:1

NOTES: UNLESS OTHERWISE SPECIFIED

- A) THIS PACKAGE CONFORMS TO JEDEC MS-012, VARIATION AC, ISSUE C, DATED MAY 1990.
- B) ALL DIMENSIONS ARE IN MILLIMETERS.
- C) DIMENSIONS DO NOT INCLUDE MOLD FLASH OR BURRS.

Ordering Information

Part Number	Temperature Range	Package
ML6554CU	0°C to 70°C	16-Pin PSOP (U16)
ML6554IU	-40°C to +85°C	16-Pin PSOP (U16)

DISCLAIMER

FAIRCHILD SEMICONDUCTOR RESERVES THE RIGHT TO MAKE CHANGES WITHOUT FURTHER NOTICE TO ANY PRODUCTS HEREIN TO IMPROVE RELIABILITY, FUNCTION OR DESIGN. FAIRCHILD DOES NOT ASSUME ANY LIABILITY ARISING OUT OF THE APPLICATION OR USE OF ANY PRODUCT OR CIRCUIT DESCRIBED HEREIN; NEITHER DOES IT CONVEY ANY LICENSE UNDER ITS PATENT RIGHTS, NOR THE RIGHTS OF OTHERS.

LIFE SUPPORT POLICY

FAIRCHILD'S PRODUCTS ARE NOT AUTHORIZED FOR USE AS CRITICAL COMPONENTS IN LIFE SUPPORT DEVICES OR SYSTEMS WITHOUT THE EXPRESS WRITTEN APPROVAL OF THE PRESIDENT OF FAIRCHILD SEMICONDUCTOR CORPORATION. As used herein:

1. Life support devices or systems are devices or systems which, (a) are intended for surgical implant into the body, or (b) support or sustain life, or (c) whose failure to perform when properly used in accordance with instructions for use provided in the labeling, can be reasonably expected to result in significant injury of the user.
2. A critical component is any component of a life support device or system whose failure to perform can be reasonably expected to cause the failure of the life support device or system, or to affect its safety or effectiveness.