

S Video Amplifier Monolithic IC MM1024

Outline

This is a video amp IC that supports S and also has border and superimpose functions. Amp gain is as follows : 6dB for Y signal amplification, 10dB for C signal amplification and 6dB for composite signal amplification. A 75Ω driver is built in.

Features

1. Supports S-VHS
2. Built-in superimpose function (character and border levels)
3. Built-in Y-C mix circuit
4. Vertical/horizontal sync signal output pin
5. Amp gain : 6dB for Y signal, 10dB for C signal and 6dB for composite signal
6. Built-in clamp circuit (for Y signal only)
7. 75Ω driver built in
8. Frequency response Y : 7MHz
 C : 5MHz
9. Power supply voltage 4.7V~5.3V

Package

SOP-16A (MM1024AF)

Applications

1. TV
2. VCR
3. VCR with camera
4. Other video equipment

Block Diagram

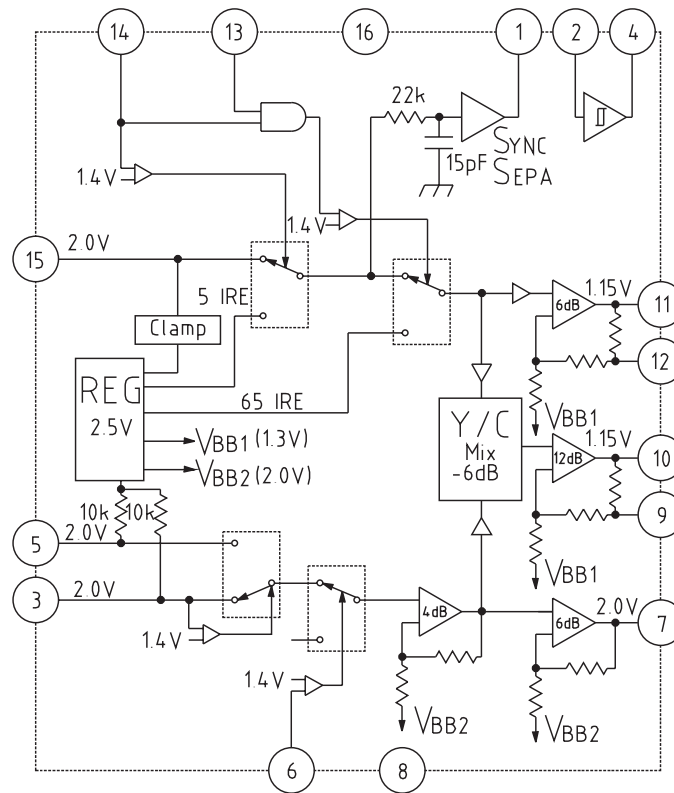

Pin Description

Pin no.	Pin name	Function
1	R	Integrates sync signal and inputs to Schmidt circuit
2	C	
3	PB _{IN}	Chroma signal input pin for other than playback
4	V _{SYNC} OUT	Vertical sync signal output pin
5	PB _{IN}	Chroma signal input pin for playback
6	Chroma mute input	Chroma mute signal input pin
7	CHROMA OUT	Chroma signal output pin
8	GND	
9	SUG	Anti-sag pin
10	VIDEO OUT	Composite video signal output pin
11	Y _{OUT}	Y (luminance) signal output pin
12	SUG	Anti-sag pin
13	Character input	Character input pin for superimpose
14	Bordering input	Bordering input pin
15	Y _{RO} VIDEO IN	Luminance or video signal input pin
16	V _{CC}	

Absolute Maximum Ratings (Ta=25°C)

Item	Symbol	Ratings	Units
Storage temperature	T _{STG}	-40~+125	°C
Operating temperature	T _{OPR}	-20~+75	°C
Power supply voltage	V _{CC} max.	7	V
Allowable loss	P _d	350	mW

Electrical Characteristics (Except where noted otherwise, Ta=25°C, Vcc=5.0V, pulse level 0V, SW1 : A, SW2 :

Item	Symbol	Measurement circuit	Measurement conditions	Min.	Typ.	Max.	Units
Operating power supply voltage	V _{CC}	V _{CC}		4.7	5.0	5.3	V
Consumption current	I _d	-	SG-1, SG-2, SG-3 : No signal Measure with DC ammeter.		25.0	33.0	mA
Y amp output							
Voltage gain	G _{v1}	TP11	SG-1, sweep signal 1V _{P-P} , 0.1MHz	5.5	6.0	6.5	dB
Differential gain	DG1	TP10	SG-1, staircase wave, 1V _{P-P} APL=10, 50, 90%		1.0	3.0	%
Differential phase	DP1	TP10	SG-1, staircase wave, 1V _{P-P} APL=10, 50, 90%		1.0	3.0	deg
Frequency characteristic	fc1	TP11	SG-1, sweep signal, 1V _{P-P} 5MHz/0.1MHz *1	-1.0	0	1.0	dB
Video amp output							
Voltage gain	G _{v2}	TP8	SG-1 sweep signal 1V _{P-P} , 0.1MHz	5.5	6.0	6.5	dB
Differential gain	DG2	TP9	SG-1, staircase wave 1V _{P-P} APL=10, 50, 90%		1.0	3.0	%
Differential phase	DP2	TP9	SG-1, staircase wave, 1V _{P-P} APL=10, 50, 90%		1.0	3.0	deg
Frequency characteristic	fc2	TP8	SG-1 sweep signal 1V _{P-P} 5MHz/0.1MHz *2	-1.0	0	1.0	dB
Chroma amp							
Voltage gain	G _{v3}	TP7	SG-2, sine wave, 0.2V _{P-P} , 0.1MHz	9.0	10.0	11.0	dB
Frequency characteristic	fc3	TP7	SG-2, sine wave, 0.2V _{P-P} 5MHz/0.1MHz *3	-1.0	0	1.0	dB
Crosstalk							
Crosstalk 1 Y _{IN} → C _{OUT}	C _{T1}	TP7	SG-1, sine wave, 1.0V _{P-P} , 4MHz *2		-36	-30	dB
Crosstalk 2 P _B → Y _{OUT}	C _{T2}	TP11	SG-2, sine wave, 0.2V _{P-P} , 4MHz *3		-42	-36	dB
Crosstalk 3 P _B → Y _{OUT}	C _{T3}	TP11	SG-3, sine wave, 0.2V _{P-P} , 4MHz SW2 : A *3		-42	-36	dB
Crosstalk 4 P _B → C _{OUT}	C _{T4}	TP7	SG-1, sine wave, 0.2V _{P-P} , 4MHz *4		-50	-40	dB
Superimpose							
Edge level Y	V _{EDY}	TP10	SG-1, staircase wave (no chroma signal) 1V _{P-P} , TP13, pulse level, 5V	0	5	10	IRE
Edge level V	V _{EDV}	TP9	SG-1, staircase wave (no chroma signal) 1V _{P-P} , TP13, pulse level, 5V	0	5	10	IRE
Character level Y	V _{CHY}	TP10	SG-1, staircase wave (no chroma signal) 1V _{P-P} , TP12, 13, pulse level, 5V	60	65	70	IRE
Character level V	V _{CHV}	TP9	SG-1, staircase wave (no chroma signal) 1V _{P-P} , TP12, 13 pulse level 5V	60	65	70	IRE
Input threshold voltage							
Bordering input	V _{TH1}	TP13	SG-1, staircase wave (no chroma signal) 1V _{P-P} , TP13, pulse level, L→H *5	0.7	1.4	2.1	V
Character input	V _{TH2}	TP12	SG-1, staircase wave (no chroma signal) 1V _{P-P} TP12, 13, pulse level, L→H *5	0.7	1.4	2.1	V
Chroma mute input	V _{TH3}	TP5	SG-2, sine wave, 0.1V _{P-P} , 4MHz TP5, pulse level, L→H *6	0.7	1.4	2.1	V
Sync separation							
Sync separation level	V _{SEPA}	TP14	SG-1, staircase wave (no chroma signal) 1V _{P-P} SG-1, SYNC level, max→min *7	55	110	165	mV
Schmitt trigger threshold voltage	V _{TH4H}	TP1	TP1, DC voltage, 0V→H *8	1.9	2.1	2.3	V
	V _{TH4L}		TP1, DC voltage, 5V→L *8	1.1	1.3	1.5	V
Vertical sync output voltage	V _{VH}	TP3	TP1, DC voltage, 5V→L *9	4.8	5.0		V
	V _{VL}		TP1, DC voltage, 0V→H *9		0.2	0.4	V

- Notes : *1 1.Voltage gain G_{v1} , G_{v2} , G_{v3}
 Given SG-1 input as V_1 and TP11 output signal as V_2 , G_{v1} is obtained as follows.
 The same applies for G_{v2} and G_{v3} .

$$G_{v1}=20\text{LOG} \frac{V_2}{V_1} \text{ [dB]}$$

- 2.Frequency response f_{c1} , f_{c2} , f_{c3}

For the same conditions as the G_{v1} measurement, given TP11 output for 0.1MHz as V_3 , and for 5MHz as V_4 , f_{c1} is obtained as follows. The same applies for f_{c2} and f_{c3} .

$$f_{c1}=20\text{LOG} \frac{V_4}{V_3} \text{ [dB]}$$

- *2 Crosstalk $Y_{IN} \rightarrow C_{OUT} C_{T1}$

Given TP14 input signal as V_5 and TP7 output signal as V_6 , C_{T1} is obtained as follows.

$$C_{T1}=20\text{LOG} \frac{V_6}{V_5} \text{ [dB]}$$

- *3 Crosstalk $\overline{P}_B, P_B \rightarrow Y_{OUT} C_{T2}, C_{T3}$

Give TP2 and TP4 input signals as V_7 , and TP11 output signal as V_8 , C_{T2} and C_{T3} are obtained as follows.

$$C_{T2}=20\text{LOG} \frac{V_8}{V_7} \text{ [dB]}$$

1.When C is input to compare between $Y_{IN} \rightarrow C_{OUT}$ and $C_{IN} \rightarrow Y_{OUT}$, subtract the 4dB amp portion from crosstalk.

- *4 Crosstalk $P_B \rightarrow C_{OUT} C_{T4}$

Given TP4 input signal as V_9 and TP7 output signal as V_{10} , C_{T4} is obtained as follows.

$$C_{T4}=20\text{LOG} \frac{V_{10}}{V_9} \text{ [dB]}$$

- *5 Input threshold voltage Bordering input, character input V_{TH1} , V_{TH2}

For the same conditions as V_{EDY} and V_{CHY} measurement, raise TP13 and TP12 pulse levels gradually. TP13 and TP12 pulse levels when bordering signal and character signal appear on TP11 are, respectively, V_{TH1} and V_{TH2} .

- *6 Input threshold voltage Chroma mute input V_{TH3}

Gradually raise TP5 pulse level. TP5 pulse level when a sine wave is no longer output on TP7 is V_{TH3} .

- *7 Sync separation level V_{SEPA}

Gradually reduce SG-1 SYNC level from maximum to minimum. Measure the SYNC signal level at TP14 when a sync separation signal is no longer output on TP15 to obtain V_{SEPA} .

- *8 Schmidt trigger threshold level V_{TH4H} , V_{TH4L}

Impress external DC voltage on TP1 and gradually raise from 0V. TP1 level when TP3 level goes from high to low is V_{TH4H} . Gradually lower from 5V. TP1 level when TP3 level goes from low to high is V_{TH4L} .

- *9 Vertical sync output voltage V_{VH} , V_{VL}

TP3 low level for T_{TH4H} measurement is V_{VL} , and TP3 high level for V_{TH4L} is V_{Vh} .

Measuring Circuit

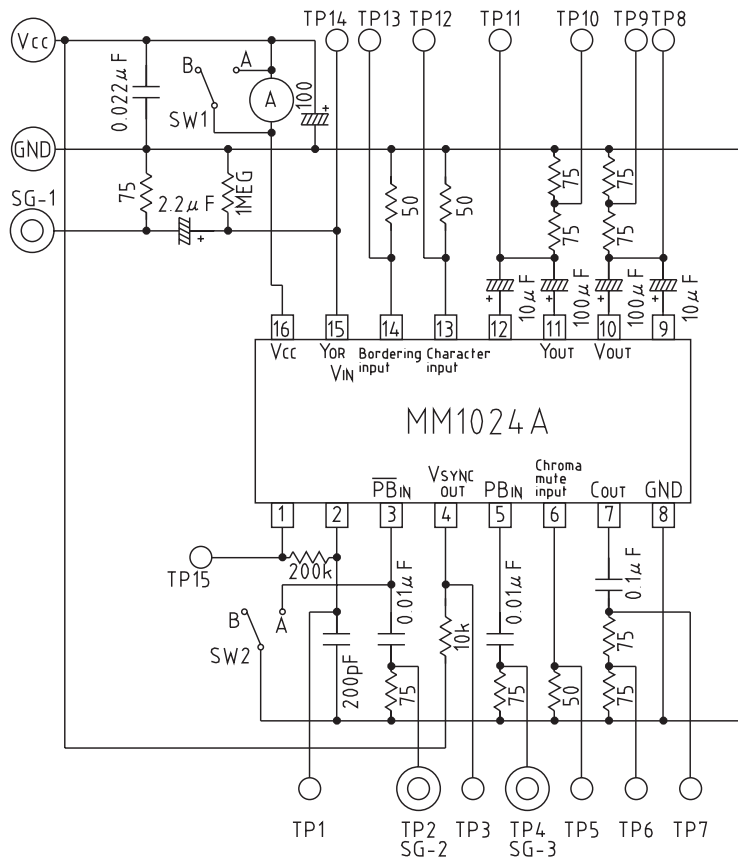

Application Circuits

