

Charge and discharge control for coin-type lithium batteries and manganese dioxide lithium batteries

Monolithic IC MM1177

Outline

This IC controls constant current charging and excess discharge for coin-shaped vanadium lithium batteries and manganese dioxide batteries. It performs constant current charging, stops charging at set voltages, and prevents excess discharging. When the voltage falls below a set level, it prohibits discharges and reduces IC current consumption nearly to zero.

Features

During charging

- | | |
|---|--|
| 1. Input voltage range | 4.0~15.0V |
| 2. Current consumption (during constant current charging) | 100 μ A typ. |
| 3. Current consumption (when charging is off) | 30 μ A typ. |
| 4. Charging current | 4.5mA typ. |
| 5. Charging shut-off voltage (Ta=-20~+70°C) | 1177AF : 3.275V \pm 75mV
1177BF : 3.0V \pm 70mV |

During discharging

- | | |
|---|-------------------|
| 1. Discharging shut-off voltage | 1.75V \pm 0.15V |
| 2. Current consumption (I _L =100 μ A, V _{BATT} =3V) | 5 μ A typ. |
| 3. Leak current during discharge shut-off | 0.1 μ A max. |
| 4. Voltage drop between battery and output (I _L =100 μ A, V _{BATT} =3V) | 2.92V typ. |

Package

SOP-8C (MM1177AF, MM1177BF)

Applications

1. coin-shaped vanadium lithium batteries
2. Monitors and controls charging and discharging for and manganese dioxide batteries.

Pin Assignment

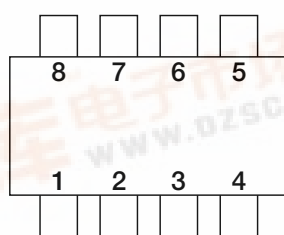

SOP-8C

1	N.C
2	GND
3	NC
4	OUT2
5	OUT1
6	BATT
7	N.C
8	V _{IN}

Block Diagram

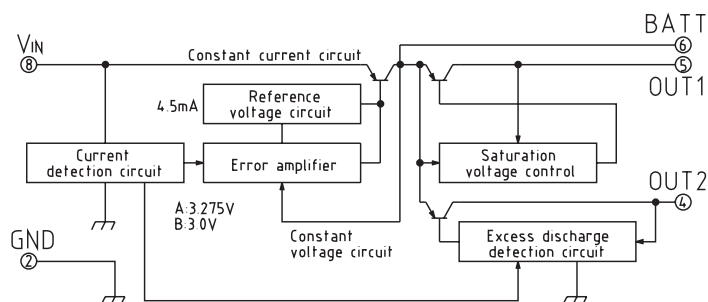

Absolute Maximum Ratings

Item	Symbol	Rating	Units
Storage temperature	T _{STG}	-40~+125	°C
Operating temperature	T _{OPR}	-20~+70	°C
input voltage	V _{IN} max.	18	V
Charging voltage	V _{BAT} max.	3.5	V
Allowable power dissipation	P _D	300	mW
Charging current	I _{BATT}	10	mA
Discharging current	I _L	1	mA

Electrical Characteristics (Unless otherwise specified Ta=25°C, V_{IN}=12.0V)

Item	Symbol	Measurement Conditions	Min	Typ.	Max.	Units
Input voltage operation range	V _{INOPR}		4.0		15.0	V
Current consumption 1	I _{IN1}	during charging (constant voltage charge)		100	180	μA
Current consumption 2	I _{IN2}	charging off		30	45	μA
Charging current (limiter current)	I _{BATT}	V _{IN} =4V~15V, V _{BATT} =2V	4.0	4.5	5.0	mA
Limiter mode off	1177AF	I _{BATT} =4mA	3.00			V
	1177BF					
Charging OFF voltage	1177AF	I _{BATT} =0mA, Ta=-20~+70°C	3.20	3.275	3.35	V
	1177BF					
Current consumption (battery)	I _{BA1}	I _L =100μA, V _{BATT} =3V		5	8	μA
Leak current when discharging is prohibited	I _{BA2}	V _{IN} =0V or open V _{BATT} =3.35V			0.1	μA
Voltage when discharging is prohibited	V _{OOFF}	after V _{IN} =0FF	1.60	1.75	1.90	V
Voltage drop between battery and output	V _{CEOUT}	I _L =100μA, V _{BATT} =3V		75	100	mV
OUT2 pin voltage	V _{OUT2}	V _{CELL} =3V	2.85	2.92	3.00	V

Note : Do not connect the OUT2 pin to the load; it does not have current supply capability.

To delay discharge prohibition, or suppress discharge prohibition caused by noise, connect a capacitor between the OUT2 pin and GND.

Operation Outline

The constant current, constant voltage charging control charges at a constant current of 4.5mA, until battery capacity reaches 0%~90%. It then switches to constant voltage control and sets the charge current to "0" when 100% charged. Output impedance is set at about 50Ω so charge current gradually drops and eventually reaches 0mA. The charging current maximum value is set by battery capacitance. Therefore, When the value falls below 4.5mA, insert a resistor (R) in series in order to lower charging current value.

The discharging control has a built-in switching circuit between the battery and output. After switching off during excess discharge, all circuit operations are prohibited. Operation reset is achieved by resuming charging. In the event of an output short, output current is limited (about 5mA~10mA) by the internal switch function. This reduces the risk of battery heat emission caused by an output short. Also, the switching circuit and the battery voltage monitoring switch are on different systems. This means that the discharge output (OUT1) will not prohibit discharge even during a short, and noise from the output load section will not affect the detection circuit (OUT2).

Application Example

■ Application Example 1

1. Charging current over 4mA

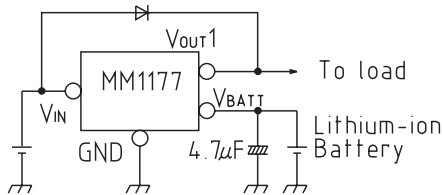

■ Application Example 2

2. Charging current under 4mA

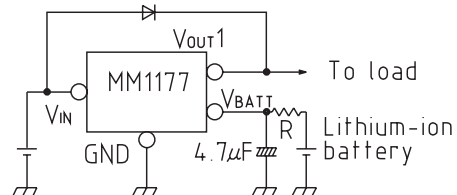

Charging Characteristics

Battery voltage-Charging current characteristics

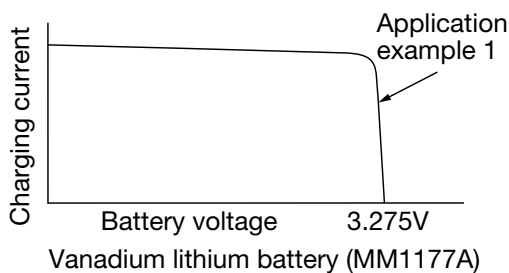

Battery voltage-Charging current characteristics

