

TFT Liquid Crystal Interface Monolithic IC MM1288CQ

Outline

This IC was developed as an interface IC for video equipment having a small monitor. This IC performs γ correction and polarity identification to convert RGB signals into TFT liquid crystal RGB signals. A common inversion circuit and sync separation circuit are built-in.

Features

1. Power supply voltage +13V, 0V or +5V, -8V
2. Built-in polarity ID circuit
3. Built-in γ correction circuit
4. Common inversion circuit built-in
5. 2 input switch built-in
6. Built-in contrast adjustment circuit
7. Built-in sync separation circuit

Package

QFP-48A

Applications

1. Navigation systems
2. Pachinko games (models with color TFT)
3. Videophones, conferencing systems
4. Game equipment
5. Others

Block Diagram

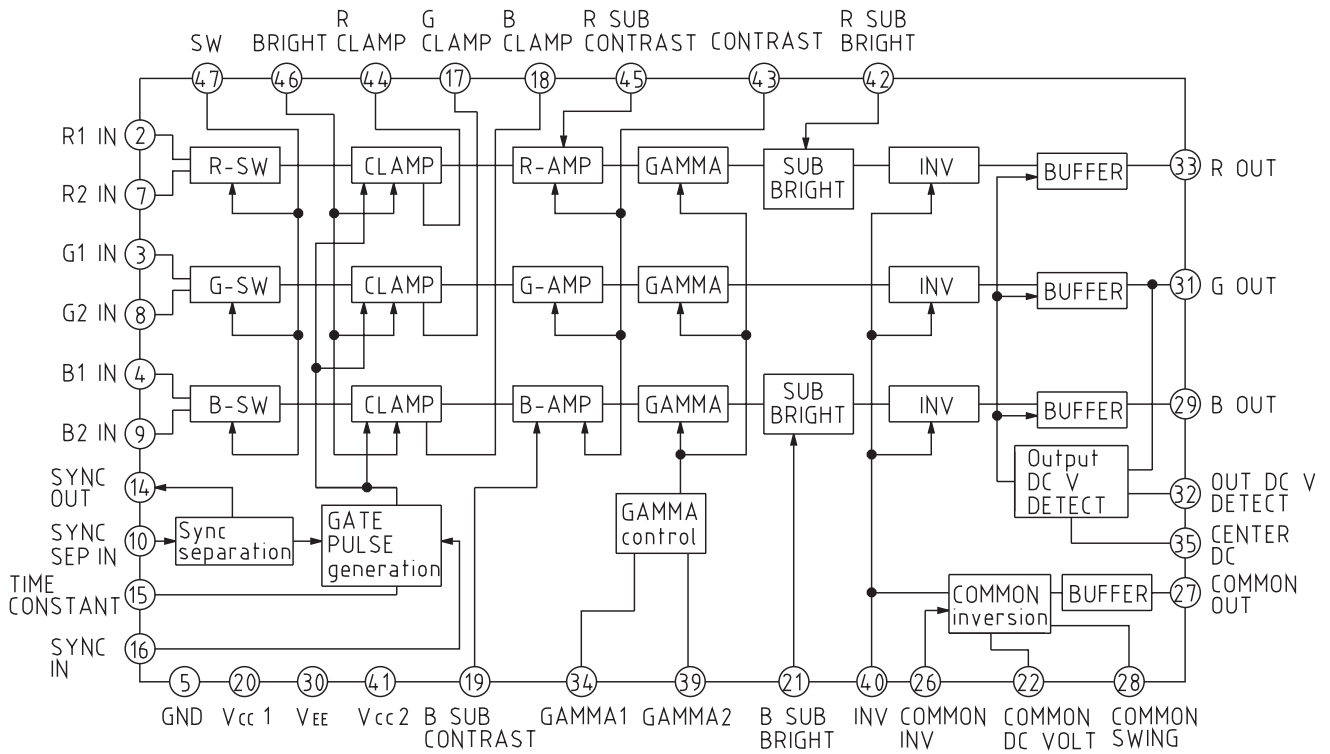

Pin Description

Pin no.	Pin name	Function	Internal equivalent circuit diagram	Pin no.	Pin name	Function	Internal equivalent circuit diagram
1, 6 11, 12 13, 23 24, 25 36, 37 38, 48	NC			14	SYNC OUT	Sync output	
2, 3 4, 7 8, 9	RGB IN	RGB input		15	TIME CONSTANT	Sync integration	
				16	SYNC IN	Sync input	
5	GND	GND pin		17, 18 44	CLAMP (RGB)	Clamp	
10	SYNC SEP IN	Sync separation input					

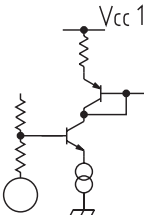
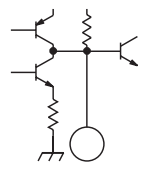
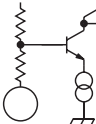
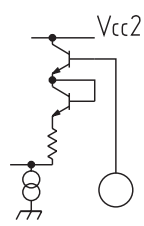
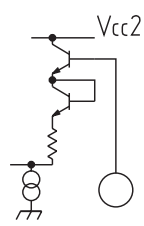
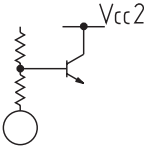
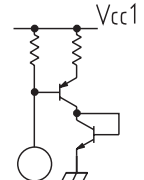
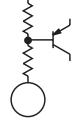
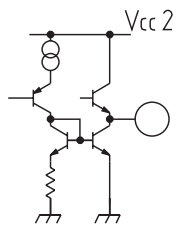
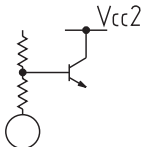
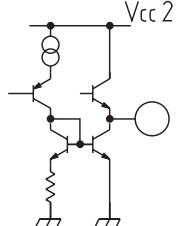
Pin no.	Pin name	Function	Internal equivalent circuit diagram	Pin no.	Pin name	Function	Internal equivalent circuit diagram
19, 45	SUB CONTRAST	Subcontrast		32	OUT DC V DETECT	G output detection	
43	CONTRAST	Contrast					
20	Vcc1	Positive polarity power supply pin 1		34	GAMMA1	Gamma correction 1	
21, 42	SUB BRIGHT	Sub bright					35
22	COMMON DC VOLT	Common operating point adjustment		39	GAMMA2	Gamma correction 2	
26	COMMON INV	Common inversion					40
27	COMMON OUT	Common output		41	Vcc2	Positive polarity power supply pin 2	
28	COMMON SWING	Common amplitude adjustment					46
29, 31 33	RGB OUT	RGB output		47	SW	Switch	
							30

Note : GAMMA1, GAMMA2 (Pins 34, 39)

DC voltage applied to these pins sets γ correction DC voltage gain change point.

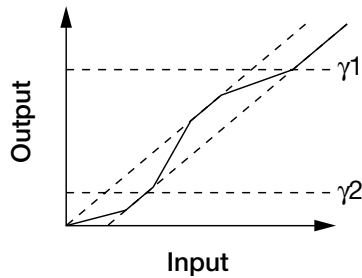

γ correction
 Output is given characteristics as shown at left according to LCD panel characteristics.
 Pins 34 and 39 adjust the slope change position.

INV (40PIN)

The primary color output (pins 29, 31, 33) and COMMON output (pin 27) are inverted according to the inversion pulse input to this pin. When COMMON INV (pin 26) has V_{CC2} potential, the relationships between the input, output and inversion pulse are as shown in the figure below.

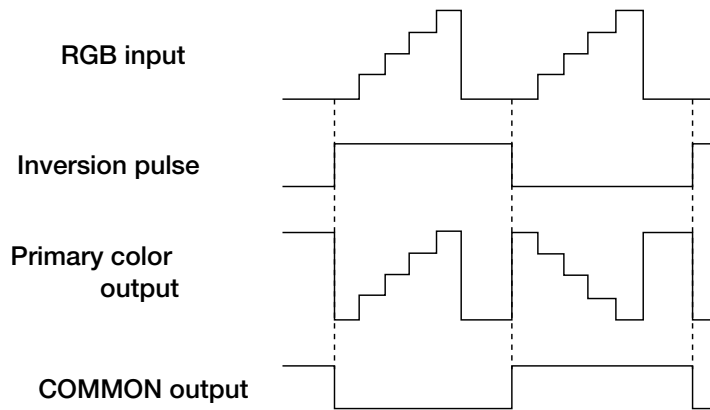

Absolute Maximum Ratings (Ta=25°C)

Item	Symbol	Ratings	Units
Storage temperature	T _{STG}	-40~+125	°C
Operating temperature	T _{OPR}	-20~+85	°C
Power supply voltage	V _{CC1} -GND	6	V
	V _{CC2} -V _{EE}	15	V
	GND-V _{EE}	10	V
Allowable loss 1	Pd 1	500	mW
Allowable loss 2	Pd 2	1000*	mW

*47mm 75mm × 0.8mm printed circuit board (glass epoxy) board mounted.

Electrical Characteristics

(Except where noted otherwise, Ta=25°C, All SW : A, Vcc1=5.0V, Vcc2=13V, GND=0V, VEE=0V, T16; SG1, T40; SG2, V46=3.5V)

Item	Symbol	Measurement conditions	Min.	Typ.	Max.	Units	
Vcc1 pin operating power supply voltage range	Vcc1		4.5	5.0	5.5	V	
Operating power supply voltage range when on power supply +2	Vcc2+2		10.0	13.0	14.0	V	
	VEE+2			GND		V	
Operating power supply voltage range when on power supply ±	Vcc2±		4.5	5.0	5.5	V	
	VEE±		-8.5	-8.0	-6.5	V	
Consumption current 1	Icc1	Vcc1=5V		8.5	15.0	mA	
Consumption current 2	Icc2	Vcc2=13V		17.0	22.0	mA	
Voltage gain	Gv	SW2~4, 7~9 ; B T2~4, 7~9 ; SG3 Adjust V46 so that T29, 31 and 33 amplitude is 8V.	Measure ratio of SG3 and T29, 31, 33 sine waves.			17	dB
Voltage gain difference between inputs	Gvsw		Measure T29, 31, 33 sine wave ratio when SW47 : B and V47=0V and 5V.			0.7	dB
Reversed/non-reversed voltage gain difference	Gvinv		Measure T29, 31, 33 sine wave ratio when T40=0V and 5V.			0.7	dB
RGB voltage gain differences	Gvrgb		Measure T29, 31, 33 sine wave ratio.			0.7	dB
Maximum voltage gain	Gv max.		SW43 ; B, V43=4.5V Measure SG3 and T29, 31, 33 sine wave ratio.		18		dB
Minimum voltage gain	Gv min.		SW43 ; B, V43=4.5V Measure SG3 and T29, 31, 33 sine wave ratio.			13	dB
Subcontrast change	ΔGvsub	SW2~4, 19, 45 ; B, T2~4 ; SG3 Adjust V46 so that T29, 31 and 33 amplitude is 8V. Measure ratio between T29, 31 and T33 sine waves when V19 and 45 are 0.5~4.5V.		±1		dB	
Input dynamic range	Vindr	SW2~4, 43 ; B, T2~4 ; SG3, V43=1.5V Adjust V46 so that T29, 31 and 33 amplitude is 9V. Vary SG3 amplitude and measure SG3 amplitude at the point where T29, 31 and 33 signals start to be saturated.	1.5	1.9		Vp-p	
Switch crosstalk	CTsw	SW2~4, 43, 47 ; B, T2~4 ; SG4, V47=5V Adjust V46 so that T29, 31 and 33 amplitude is 8V, and adjust V43 so that T29, 31 and 33 sine wave amplitude is 5Vp-p. Vary SW47 in this state and measure 1MHz spectrum change.		-50	-44	dB	
		SW7~9, 43, 47 ; B, T7~9 ; SG4, V47=5V Adjust V46 so that T29, 31 and 33 amplitude is 8V, and adjust V43 so that T29, 31 and 33 sine wave amplitude is 5Vp-p. Vary SW47 in this state and measure 1MHz spectrum change.		-50	-44	dB	

Item	Symbol	Measurement conditions	Min.	Typ.	Max.	Units
Crosstalk between RGB	C_{TRGB}	SW2 ; B T2 ; SG4 Adjust V46 so that T33 amplitude is 8V, and adjust V43 so that T33 sine wave amplitude is 5V _{P-P} . Then measure the difference between T33 and T29, 31 signals 1MHz spectrum. Measure in the same way for G → B,R and B → R, G.		-48	-40	dB
Output dynamic range (B-B)	V_{DRB-B}	SW2~4 ; B, T2~4 ; SG4, V46=0.5V Measure T29, 31 and 33 signals.	10	11		V _{P-P}
Output dynamic range (B-W)	V_{DRB-W}	SW2~4, 43 ; B, T2~4 ; SG4, V43=4.5V Adjust V46 so that T29, 31 and 33 amplitude is 9V and measure T29, 31 and 33 sine wave amplitude.	6.0	7.0		V _{P-P}
Output center voltage	V_C	Adjust V46 so that T29, 31 and 33 amplitude is 0V and measure T29, 31 and 33 DC voltage.	6.3	6.5	6.7	V
Output center voltage change	ΔV_C	Adjust V46 so that T29, 31 and 33 amplitude is 0V and measure the difference T29, 31 and 33 DC voltage when V35=5V and 8v		3.0		V
Bright change	ΔV_{BRIT}	Measure the difference between T29, 31 and 33 signal clamp levels when V46=0.5V and 4.5V.	10.0	13.5		V
Amplitude difference between bright RGB signals	$V_{BRIT RGB}$	Adjust V46 so that T31 amplitude is 5.7V and measure T29 and 33 amplitude ratio.	-0.5		0.5	dB
Sub-bright change	ΔV_{SUBB}	After adjusting V46 so that T29, 31 and 33 amplitude is 6V, with SW21 and 42 : B, vary V21 and 42 between 8~10V and measure the maximum value of the difference between T31 and T29, 33 amplitudes.		±1		V
Frequency characteristic	$f_{max.}$	SW2~4, 29, 31, 33 ; B, T2~4 ; SG4 Adjust V46 so that T29, 31 and 33 amplitude is 8V, then adjust V43 so that T29, 31 and 33 sine wave amplitude is 5V _{P-P} . Vary sine wave frequency at measure cutoff frequency.	4.0	5.0		MHz
COMMON output amplitude	V_{COM}	Measure T27 amplitude.	6.0	6.5		V _{P-P}
COMMON output maximum amplitude	$V_{COM max.}$	SW28 ; B, V28=12V Measure T27 amplitude.	8.0			V _{P-P}
COMMON output minimum amplitude	$V_{COM min.}$	SW28 ; B, V28=0V T27 amplitude.	-0.1	0	0.1	V _{P-P}
COMMON output center maximum voltage	$V_{CO max.}$	SW22, 28 ; B, V22=5V, V28=0V Measure T27 amplitude.	8.5			V
COMMON output center minimum voltage	$V_{CO min.}$	SW22, 28 ; B, V22=0.5V, V28=0V Measure T27 DC voltage			4.5	V
Sync separation input sensitivity current	I_{IS}	Increase current flowing out on T10, and measure outflow current when T14 voltage changes from high to low.	-50	-35	-20	μA
Sync separation output low voltage	V_{SYNL}	Measure T14 voltage when 5V is applied to T10.		0.2	0.4	V
Sync input threshold voltage	V_{TH15}	Measure T14 inverted input voltage when T16 voltage is changed from 0 → 5V.	1.4	1.9	2.4	V
Sync input input current	I_{I5}	SW16 ; B Apply 0V to T16 and measure I16.	-1.5			μA
Subcontrast input current	$I_{I8, I41}$	SW19, 45, 46 ; B Measure I19 and 45 when V19 and 45 are 0.5V and 4.5V.	-60		70	μA

Item	Symbol	Measurement conditions	Min.	Typ.	Max.	Units
Sub-bright input current	I20, I38	SW21, 42, 46 ; B Measure I21 and 42 when V21 and 42 are 7.5V and 10.5V.	-50		40	μA
COMMON DC VOLT input current	I21	SW22 ; B Measure I22 when V22=0V.	-100			μA
COMMON INV threshold voltage	V _{TH} 24	SW26 ; B Vary V26 between 0~13V and measure V26 when T27 phase inverts.	6.0	6.5	7.0	V
COMMON INV input current	I24	SW26 ; B Measure I26 when V26=0 and 13V.	-90		90	μA
COMMON SWING input current	I26	SW28 ; B Measure I26 when V26=9 and 12V.	-60		60	μA
GAMMA1 input voltage	I32	SW34 ; B Measure I34 when V34=11V.			6	μA
GAMMA2 input voltage	I35	SW39 ; B Measure I39 when V39=1V.	-6			μA
INV threshold voltage	V _{TH} 36	Vary T40 voltage from 0 → 5V and measure the voltage when T27 phase inverts.	2.5	3.0	3.5	V
INV input current	I36	Measure I40 when V40 is 0V.	-2			μA
Contrast input current	I39	SW43 ; B Measure I43 when V43 is 0.5V and 4.5V.	-60		70	μA
Bright input current	I42	Measure I46 when V46=1.7V.			3	μA
CENTER DC input current	I35	Measure I35 when V35=V _{CC} 2	105	110	165	μA
SW threshold voltage	V _{TH} 47	SW2~4, 47 ; B, T2~4 ; SG3 Adjust V46 so that T29, 31 and 33 amplitude is 8V. Vary V47 voltage from 0 → 5V and measure V47 when T29, 31 and 33 sine waves disappear.	0.8	1.4	2.0	V
SW input current	I43	SW47 ; B Measure I47 when V47=0V.			4.5	μA
GAMMA1 fluctuation	ΔV34	SW2~4, 34, 43 ; B, T2~4 ; SG5 Adjust V43 so that T29, 31 and 33 amplitude is 3V. Vary V34 voltage from 3→6V and measure the amount of T29, 31 and 33 voltage change.	0.8	1.2	2.1	V
GAMMA2 fluctuation	ΔV39	SW2, 3, 4, 39, 43 ; B, T2~4 ; SG5 Adjust V43 so that T29, 31 and 33 amplitude is 3V. Vary V39 voltage from 6.2→8V and measure the amount of T29, 31 and 33 voltage change.	0.8	1.2	2.1	V
H-to-L common transport delay time	t _{PHL}	SW27, 28 ; B, T40 ; SG6 Adjust V28 so that T27 amplitude is 6V.			2	μS
L-to-H common transport delay time	t _{PLH}				2	μS
COMMON fall time	t _{THL}		2	3	μS	
COMMON rise time	t _{TLH}		2	3	μS	
Difference in COMMON rise and fall times	Δtr	Δtr= t _{THL} -t _{TLH}			2	μS
H-to-L primary color signal transport delay time	t _{PHL}	SW29, 31, 33 ; B, T40 ; SG6 Adjust V46 so that T29, 31 and 33 amplitude is 8V.			2	μS
L-to-H primary color signal transport delay time	t _{PLH}				2	μS
Primary color signal fall time	t _{THL}		1	2	μS	
Primary color signal rise time	t _{TLH}		1	2	μS	
Difference in primary color signal rise and fall times	Δtr		Δtr= t _{THL} -t _{TLH}			1

Example of Power Supply Use

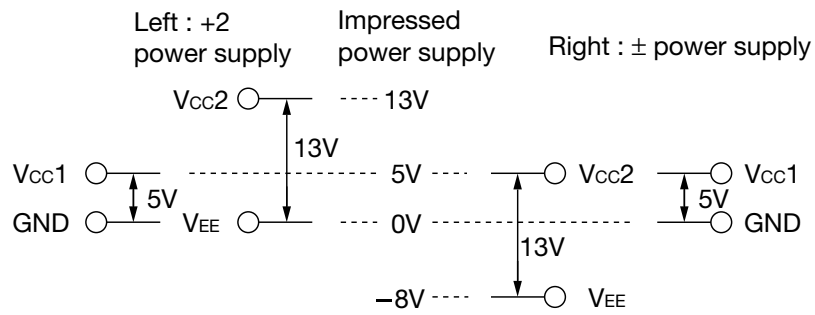

Input Signal Waveforms

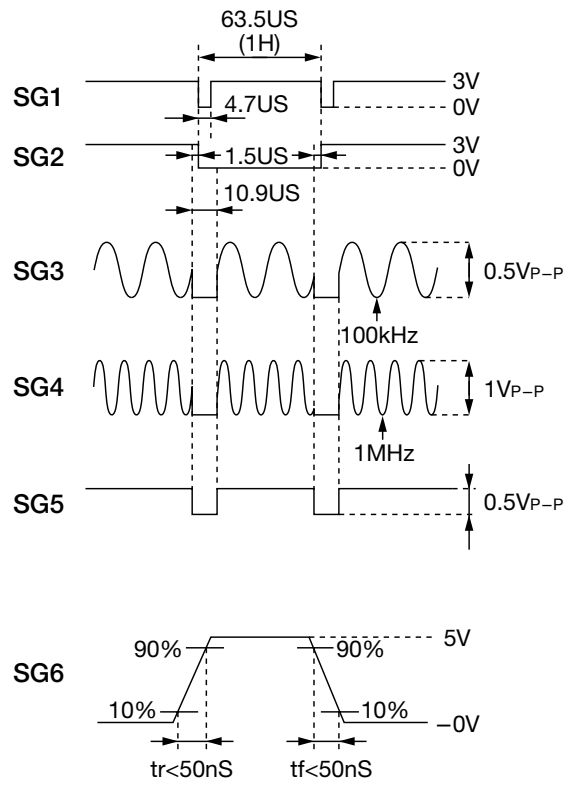

Measuring Circuit

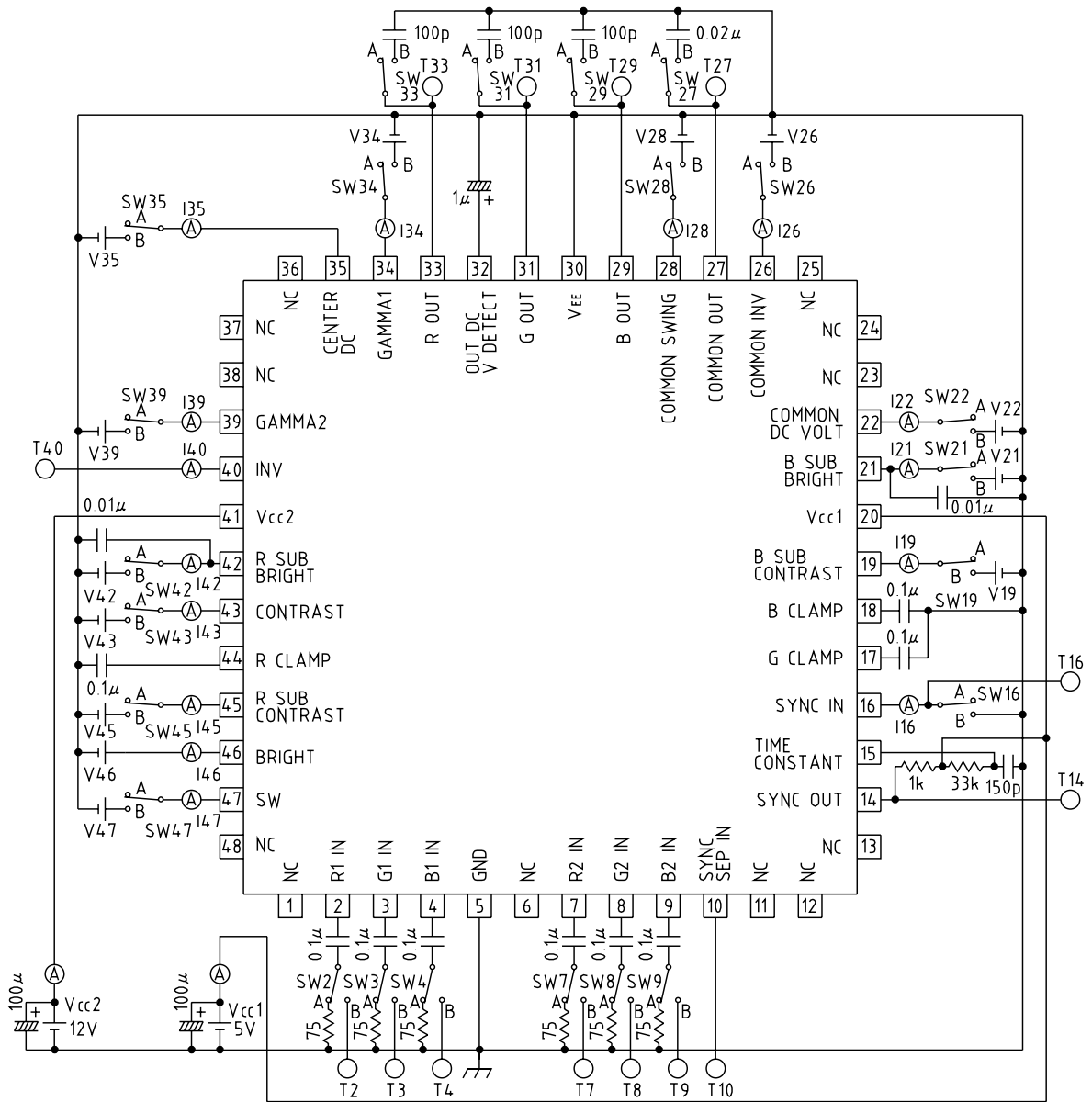

Application Circuits

Basic Connection Diagram 1 (Vcc1=5V, Vcc2=13V)

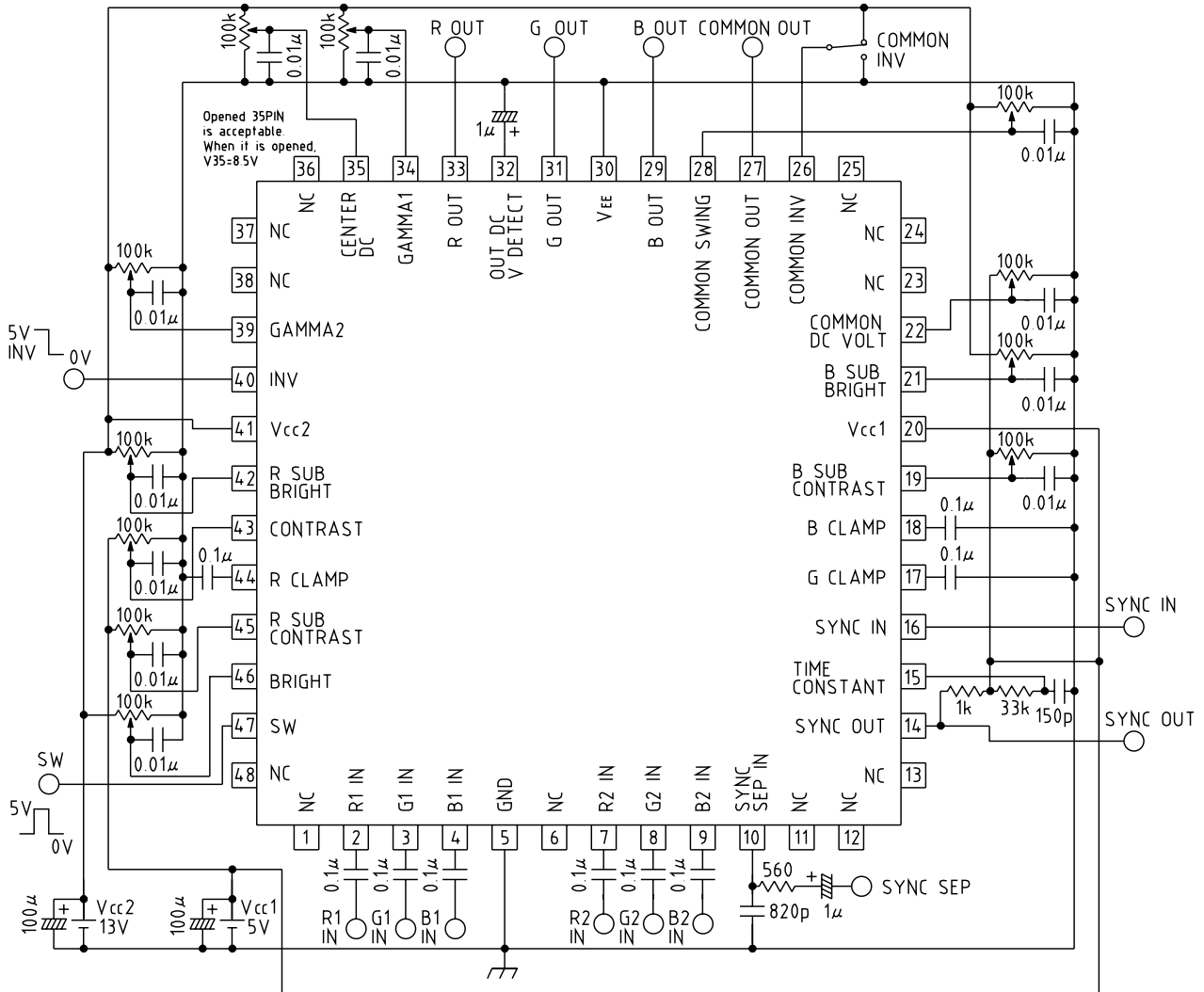

Basic Connection Diagram 2 (VCC=5V, VEE=-8V)

