

LCD Interface Monolithic IC MM1323

Outline

This IC was developed for interface with digital video equipment having an LCD monitor. It can be used as interface for CPU, DSP and LCD drivers that output RGB signals after output polarity inversion and γ correction processing. It has a built-in post filter (5MHzLPF), 16.5dB amp and 20dB common amp.

Features

1. Built-in post filter 5MHz LPF
2. Built-in amp $G_v=16.5\text{dB}$
3. Adjustable white balance
4. Built-in common amp $G_{v\text{COM}}=20\text{dB}$

Package

SSOP-24 (0.8mm pitch)
TSOP-24 (0.5mm pitch)

Applications

1. Navigation systems
2. Digital cameras
3. Pachinko games (with color TFT)
4. Videophones, conferencing systems
5. Other game equipment

Circuit Connection Diagram

RGB signal after polarity inversion and γ correction processing

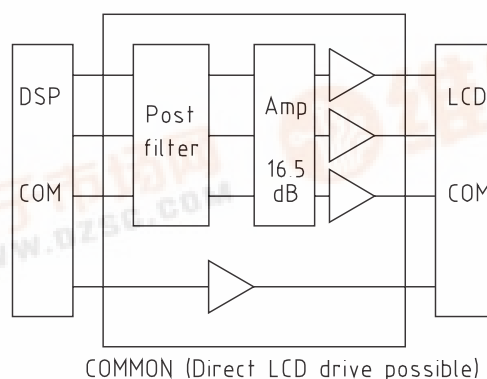

Block Diagram

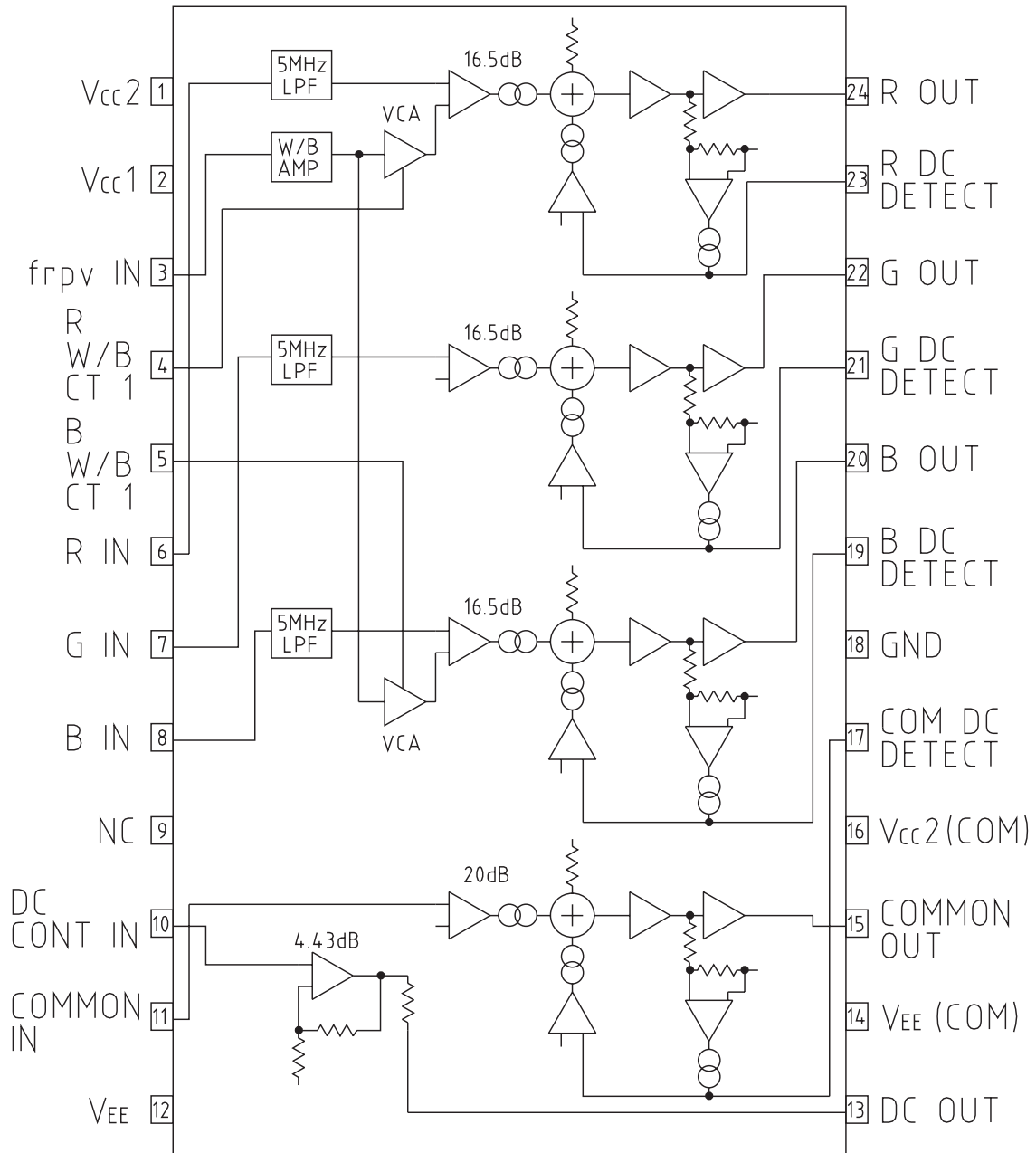

Pin Description

Pin no.	Pin name	Function	Internal equivalent circuit diagram
1	Vcc2		
2	Vcc1		
3	frpv IN		
4	RW/B CT1	White balance control	
5	BW/B CT1		
6	R IN	RGB input	
7	B IN		
8	B IN		
9	NC		
10	DC CONT IN	DC control input	
11	COMMON IN	Common input	

Pin no.	Pin name	Function	Internal equivalent circuit diagram
12	V _{EE}		
13	DC OUT	DC output	
14	V _{ee}		
15	COMMON OUT		
16	V _{cc2}		
17	DC DETECT	Output detection	
18	GND		
19 21 23	DC DETECT	Output detection	
20 22 24	B OUT G OUT R OUT	RGB output	

Electrical Characteristics (Except where noted otherwise, Ta=25°C, Vcc1=4.9V, Vcc2=6.5V, VEE=-6.5V all SW ; A)

Item	Symbol	Measurement conditions	Min.	Typ.	Max.	Units		
Operating power supply voltage	V _{CC1}		4.8	4.9	5.0	V		
	V _{CC2}		6.0	6.5	7.0	V		
	V _{EE}		-7.0	-6.5	-6.0	V		
Consumption current	I _{CC1}	No load		11.5	15.0	mA		
	I _{CC2}	No load		8.5	11.0	mA		
	I _{EE}	No load		7.0	9.0	mA		
RGB								
Voltage gain	G _V	SW1, SW2, SW3=B V1, V2=1.5V TP5, TP6, TP7=0.6V _{P-P} , 100kHz sine wave Measure sine wave ratio between input signal and TP12, 13 and 14	R	16.0	16.5	17.0	dB	
		G	16.0	16.5	17.0			
		B	16.0	16.5	17.0			
Voltage gain difference between channels	G _{VCH}	Measure voltage gain difference between each RGB channel.	R-G	-0.5	0.0	0.5	dB	
			R-B	-0.5	0.0	0.5		
			G-B	-0.5	0.0	0.5		
Output dynamic range	V _{ODR}	SW1, SW2, SW3=B V1, V2=1.5V TP5, TP6, TP7=0.6V _{P-P} 100kHz sine wave Vary input signal amplitude and measure TP12, 13 and 14 amplitude at the point where TP12, 13 and 14 signals start to saturate.	R	4.25			V _{P-P}	
			G	4.25				
			B	4.25				
Output center voltage	V _C	Input a 0.6V _{P-P} , 7.86kHz rectangular wave to TP5, 6 and 7, and measure TP12, 13 and 14 center voltage.	R	2.3	2.5	2.7	V	
			G	2.3	2.5	2.7		
			B	2.3	2.5	2.7		
Load fluctuation	ΔV _{OL}	Measure TP12, 13 and 14 DC voltage fluctuation when TP12, 13 and 14 load current is varied from 0 → ±6mA.	R	-0.2	0	0.2	V	
			G	-0.2	0	0.2		
			B	-0.2	0	0.2		
Frequency characteristic	F _C	SW1, SW2, SW3=B V1, V2=1.5V TP5, TP6, TP7=0.6V _{P-P} sweep signal For 100kHz, measure frequency when attenuated -3dB relative to TP12, 13 and 14 signals.	R	4.0	5.0			
			G	4.0	5.0			
			B	4.0	5.0			
W/B								
Common-mode output amplitude	V _{W/BO1}	TP1=5.0V _{P-P} 7.86kHz rectangular wave Confirm that TP12 and 14 signals are in phase with TP1, then measure amplitude.	R	1.5			V _{P-P}	
			B	1.5				
Negative-phase output amplitude	V _{W/BO2}	TP1=5.0V _{P-P} 7.86kHz rectangular wave Confirm that TP12 and 14 signals are reverse phase from TP1, then measure amplitude.	R	1.5			V _{P-P}	
			B	1.5				
frpv input threshold voltage	V _T	Measure TP18 voltage, then impress that voltage on TP18. Given V1=0V, add DC voltage to TP1. Raise gradually from 0V and measure TP1 voltage when TP14 voltage goes over 2.5V.		1.0	1.7	2.4	V	
Output center voltage	V _C	TP1=5.0V _{P-P} 7.86kHz rectangular wave Adjust V1 and V2 within 0~1.5V (in phase) and set TP12 and 14 amplitude at 1.5V. Measure TP12 and TP14 center voltage. Measure in the same way for V1 and V2 adjusted within 1.5~3.0V (reverse phase).	Common-mode	R	2.3	2.5	2.7	V
				B	2.3	2.5	2.7	
			Negative-phase	R	2.3	2.5	2.7	
				B	2.3	2.5	2.7	
COMMON								
COMMON voltage gain	G _{VCOM}	SW4=B TP9=1.0V _{P-P} 100kHz sine wave Measure ratio of input signal and TP11 sine wave.		19.5	20.0	20.5	dB	
COMMON output center voltage	V _{CO}	SW4=B TP9=1.0V _{P-P} 7.86kHz rectangular wave Measure TP11 center voltage.		-0.2	0	0.2	V	
COMMON load fluctuation	ΔV _{OLC}	Measure TP11 DC voltage fluctuation when TP11 load current is varied from 0 → ±100mA.		-0.5	0	0.5	V	
Center DC adjustment								
Output voltage L	V _{OL}	SW5=B, V3=0V, Measure TP10 DC voltage.		-1.3	-1.0	-0.7	V	
Output voltage H	V _{OH}	SW5=B, V3=3V, Measure TP10 DC voltage.		3.7	4.0	4.3	V	

Absolute Maximum Ratings (Ta=25°C)

Item	Symbol	Ratings	Units
Storage temperature	T _{STG}	-40~+125	°C
Operating temperature	T _{OPR}	-20~+75	°C
Power supply voltage	V _{CC} -GND	8	V
	V _{EE} -GND	-8	V
Allowable loss	P _d	650	mW

Measuring Circuit

