

# Regulator+Reset IC Monolithic IC MM1478

## Outline

This IC, developed for use in CD-ROM drives, combines a 3V regulator adapted to low power consumption with a much-sought reset function (regulator input monitoring), with internal delay circuit, set to detect 4.2V.

## Features

1. Large output current 300mA max.
2. High ripple rejection rate 80dB typ.
3. Internal thermal shutdown circuit.
4. Internal current-limiting circuit.
5. Adjustment-free reset detection voltage 4.2V typ.
6. Easy to set delay time from voltage detection to reset release.

## Rank table

Rnak	Regulator output voltage (V)	Detection voltage (V)
A	3.40±0.05	4.20±0.09
D	3.30±0.05	4.20±0.09
F	3.30±0.05	3.90±0.09
M	2.50±0.05	4.20±0.09

## Package

SOP-8D

## Applications

CD-ROM drive.

## Pin Assignment

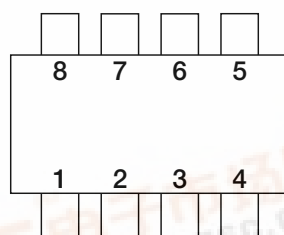

SOP-8D  
(TOP VIEW)

1	N. C
2	RESET
3	CONT
4	V <sub>IN</sub>
5	V <sub>OUT</sub>
6	N. C
7	GND
8	Cd

Equivalent Circuit Diagram

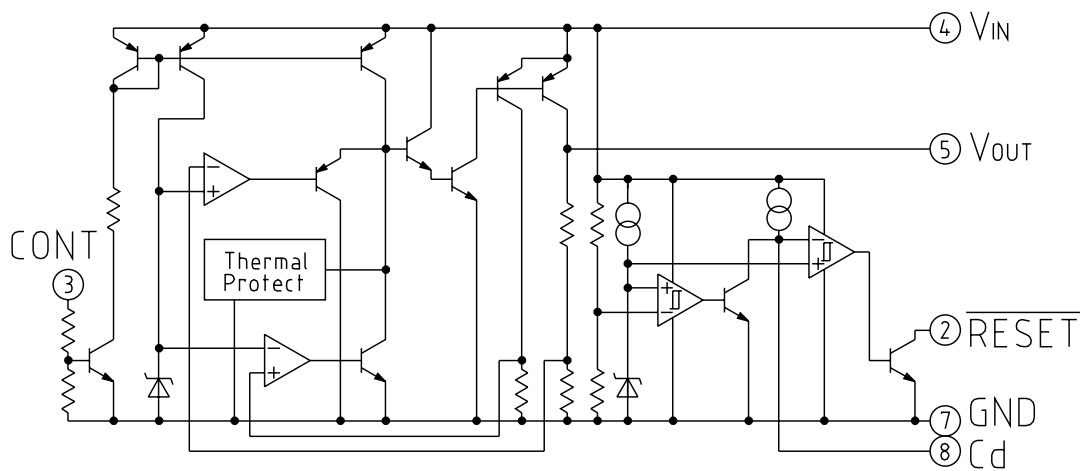

Pin Description

Pin No.	Pin name	Functions	Equivalent circuit diagram						
1	N. C								
2	RESET	Input voltage detection output Input voltage detection output pin RESET pin logic <table border="1" style="margin-left: 20px;"> <tr> <td></td> <td>RESET</td> </tr> <tr> <td><math>V_{IN} &lt; V_S</math></td> <td>L</td> </tr> <tr> <td><math>V_{IN} &gt; V_S</math></td> <td>H</td> </tr> </table>		RESET	$V_{IN} < V_S$	L	$V_{IN} > V_S$	H	
	RESET								
$V_{IN} < V_S$	L								
$V_{IN} > V_S$	H								
3	CONT	Output voltage on/off-control pin <table border="1" style="margin-left: 20px;"> <tr> <td><math>V_{CONT}</math></td> <td>Output</td> </tr> <tr> <td>L</td> <td>OFF</td> </tr> <tr> <td>H</td> <td>ON</td> </tr> </table> Connect cont-terminal with $V_{IN}$ , when it is not used.	$V_{CONT}$	Output	L	OFF	H	ON	
$V_{CONT}$	Output								
L	OFF								
H	ON								
4	$V_{IN}$	Voltage supply input pin							
5	$V_{OUT}$	Regulator Output pin							
6	N. C								
7	GND	GND pin							
8	$C_d$	Delay time capacitor pin RESET pin output delay time can be set by the capacitance connected to the $C_d$ pin. $t_{PLH} = 100000 \cdot C$ $t_{PLH}$ : transmission delay time [s] $C$ : capacitor value [F]							

## Absolute Maximum Ratings

Item	Symbol	Ratings	Unit
Operating temperature	T <sub>OPR</sub>	-30~+85	°C
Storage temperature	T <sub>STG</sub>	-40~+125	°C
Supply voltage	V <sub>IN</sub>	-0.3~+10	V
Output current	I <sub>OUT</sub>	400	mA
Power dissipation	P <sub>d</sub>	700*	mW

Note: \* When mounted on a 25×40×1<sup>t</sup> mm glass epoxy board.

## Recommended Operating Conditions

Item	Symbol	Ratings	Unit
Operating temperature	T <sub>OP</sub>	-20~+85	°C
Output current	I <sub>OP</sub>	0~300	mA
Operating voltage	V <sub>OP</sub>	0~10	V

## Electrical Characteristics (Typical model MM1478A) (Except where noted otherwise, T<sub>a</sub>=25°C, V<sub>CONT</sub>=1.6V) (Except where noted otherwise, resistance unit is Ω)

Item	Symbol	Measurement conditions	Min.	Typ.	Max.	Unit
No-load input current 1	I <sub>ccq1</sub>	V <sub>IN</sub> =5V, I <sub>OUT</sub> =0mA		3	8	mA
No-load input current 2	I <sub>ccq2</sub>	V <sub>IN</sub> =4V, I <sub>OUT</sub> =0mA		4		mA
Input current (OFF)	I <sub>ccq3</sub>	V <sub>IN</sub> =5V, V <sub>CONT</sub> =0.4V		250		μA
<b>Regulator</b>						
Output Voltage	V <sub>OUT</sub>	V <sub>IN</sub> =5V, I <sub>OUT</sub> =30mA	3.33	3.40	3.47	V
Input-Output differential Voltage	V <sub>i0</sub>	V <sub>IN</sub> =3.2V, I <sub>OUT</sub> =150mA		0.15	0.3	V
Line regulation	ΔV <sub>1</sub>	V <sub>IN</sub> =4.4~5.5V, I <sub>OUT</sub> =30mA		10	20	mV
Load regulation	ΔV <sub>2</sub>	V <sub>IN</sub> =5V, I <sub>OUT</sub> =0~300mA		20	120	mV
V <sub>OUT</sub> temperature coefficient *	ΔV <sub>OUT</sub> / ΔT	T <sub>j</sub> =-20~+80°C, V <sub>IN</sub> =5V I <sub>OUT</sub> =30mA		100		ppm/°C
Ripple rejection *	RR	V <sub>IN</sub> =5V, f=120Hz V <sub>RIPPLE</sub> =1V <sub>P-P</sub> , I <sub>OUT</sub> =30mA	50	80		dB
Output noise voltage *	V <sub>n</sub>	V <sub>IN</sub> =5V, f=20~80kHz I <sub>OUT</sub> =30mA		40	120	μV <sub>rms</sub>
CONT terminal current	I <sub>ON</sub>	V <sub>CONT</sub> =1.6V		5	10	μA
High threshold voltage	H		1.6		V <sub>IN</sub> +0.3	V
Low threshold voltage	L		-0.3		0.4	V
<b>Reset</b>						
Detection voltage	V <sub>S</sub>	V <sub>IN</sub> =H→L	4.11	4.20	4.29	V
V <sub>S</sub> temperature coefficient *	ΔV <sub>S</sub> / ΔT	T <sub>j</sub> =-20~+80°C		100		ppm/°C
Hysteresis voltage	ΔV <sub>S</sub>	V <sub>IN</sub> =H→L→H	100		200	mV
Low-level output voltage	V <sub>OL</sub>	V <sub>IN</sub> =3.9V, R <sub>L</sub> =4.7k		100	200	mV
Output leakage current	I <sub>OH</sub>	V <sub>IN</sub> =5V			±0.1	μA
Output current 1	I <sub>OL1</sub>	V <sub>IN</sub> =3.9V, R <sub>L</sub> =0	5			mA
Output current 2 *	I <sub>OL2</sub>	V <sub>IN</sub> =3.9V, R <sub>L</sub> =0, T <sub>a</sub> =-20~+80°C	3			mA
"H" transmission delay time *	t <sub>PLH</sub>	C <sub>d</sub> =0.0μF		30	90	μs
Reset delay time	t <sub>PLH1</sub>	V <sub>IN</sub> =4V→5V, C <sub>d</sub> =0.1μF	5	10	20	ms
"L" transmission delay time *	t <sub>PHL</sub>			30	90	μs
Threshold operating voltage	V <sub>OPL</sub>	V <sub>OL</sub> =0.4V		0.65	0.85	V

Note 1: design guaranteed

Measuring Circuit

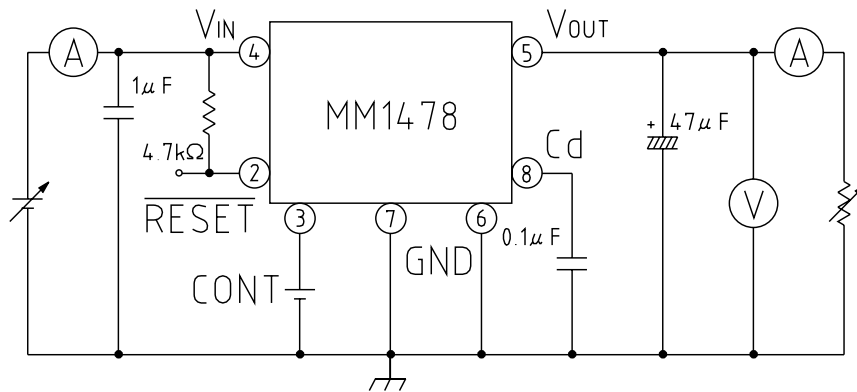

Application Circuit

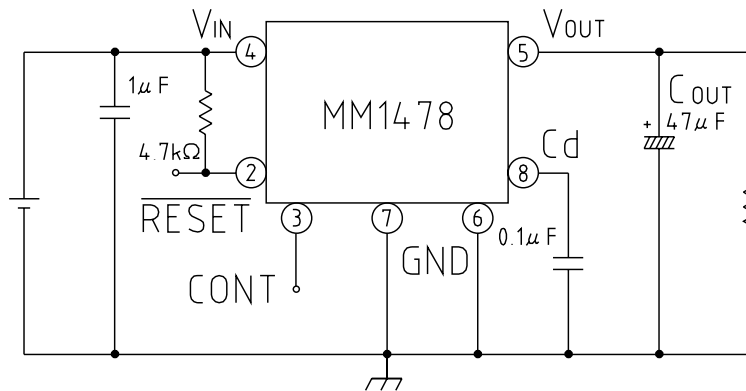

Note 1 : This regulator is not internally compensated and thus requires an external output-capacitor ( $C_{OUT}$ ) for stability.

Timing Chart

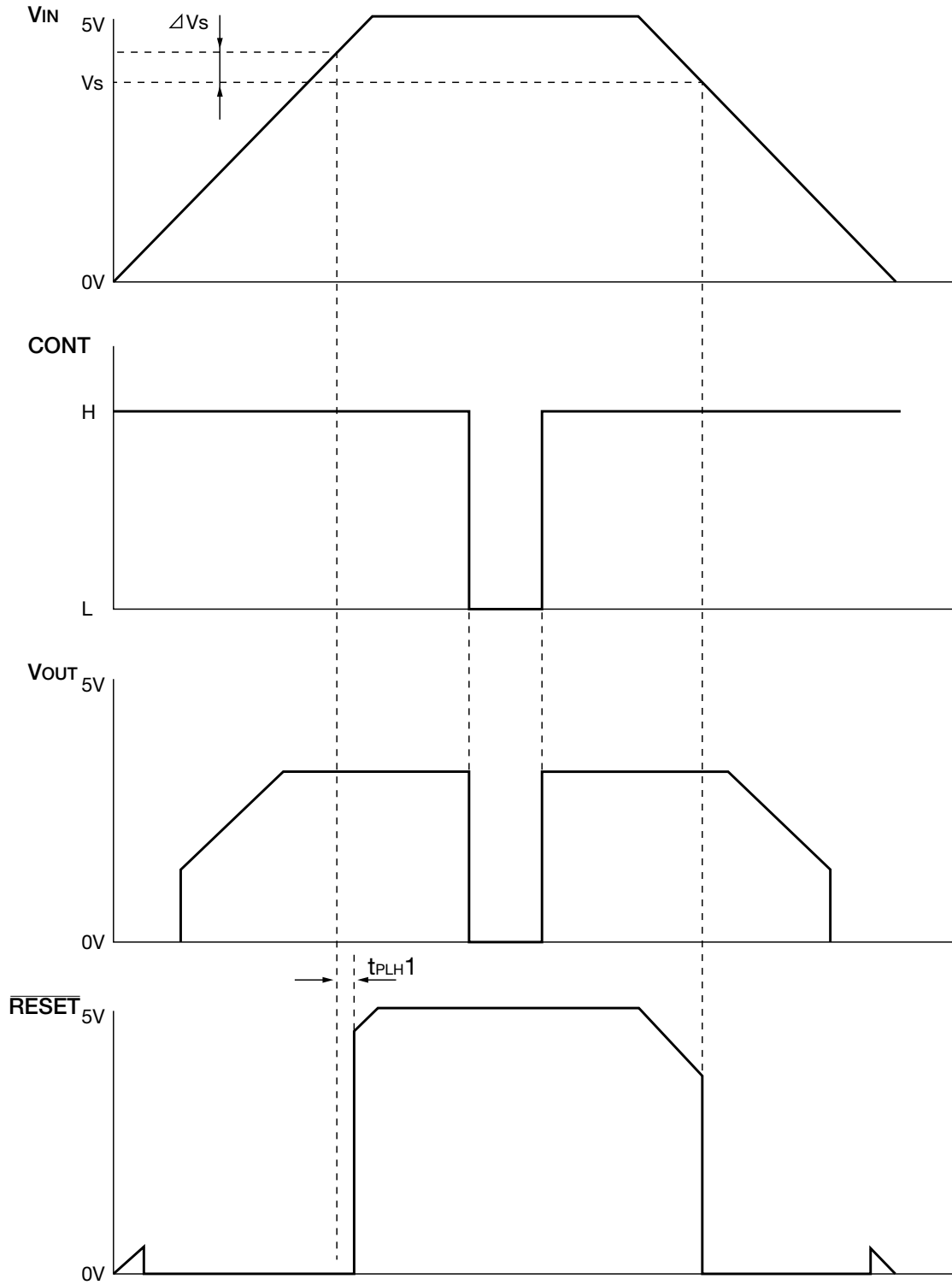

**Characteristics** (Typical model MM1478A)

■ Detection voltage ( $I_{OUT}=0mA$ )

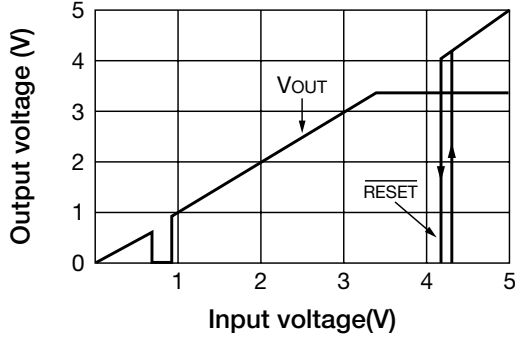

■ Output voltage vs temperature

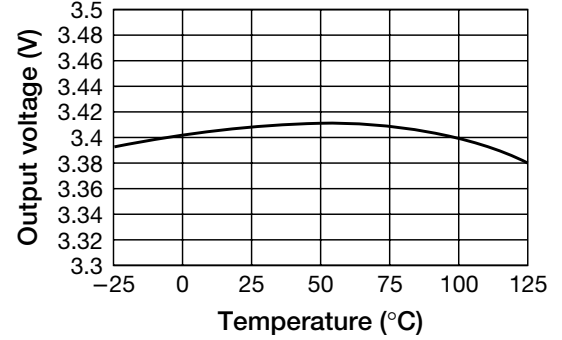

■ Line regulation

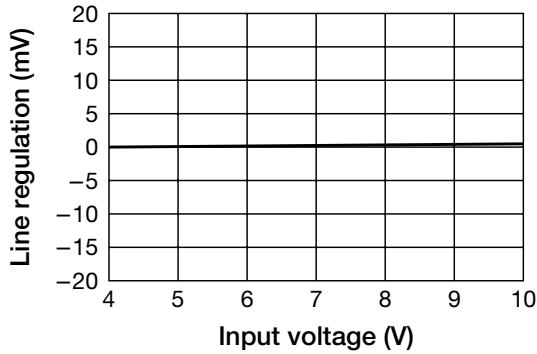

■ Load regulation

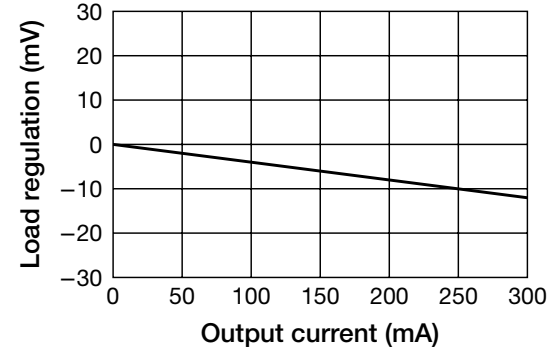

■ Ripple rejection

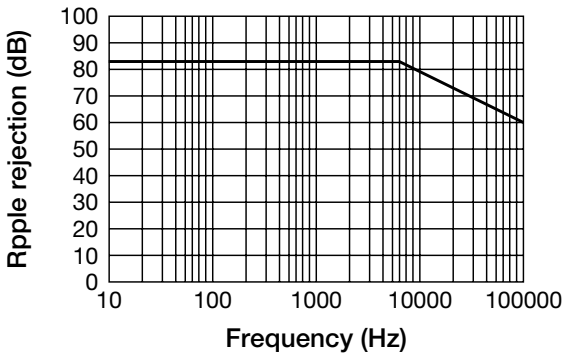

■ Detecting voltage vs temperature

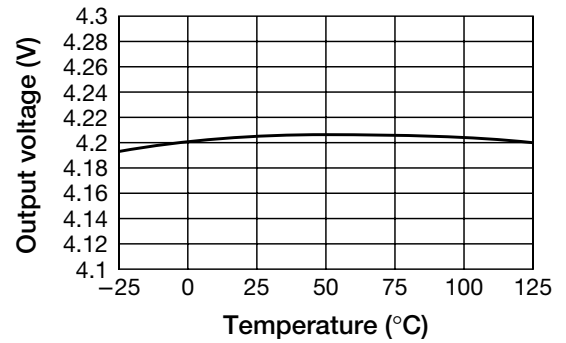

■ Allowable loss

